

FM1233A

3-Pin μ C Supervisor Circuit

General Description

The FM1233A is a supervisor circuit that monitors a microprocessor power supply or other system voltage and issues a reset pulse when a fault condition exists. Several different threshold voltages are offered to accommodate 3.3V and 3.0V systems with different tolerances.

FM1233A features a precision temperature-compensated voltage reference and comparator. When V_{CC} falls to the threshold voltage, a RESET pulse is issued, holding the output in the active state. When power rises above V_{TH} , the reset remains asserted for a minimum period (t_{RST}) to allow the system clock and other circuits to stabilize. The reset output of FM1233A is of open-drain active low type.

The FM1233A also can monitor a switch closure on its output, enabling it to recognize an external reset from a pushbutton switch or a μ P. In the case of a switch, the closure will be debounced by circuitry internal to the FM1233A.

Features

- Precision monitoring of 3.3V and lower voltage microprocessor systems
- V_{TH} values of 3.08V, 2.88V and 2.72V
- Automatic restart of microprocessor after power failure
- Reset Timeout Period Choice:
 - Options AC and AD: 140ms (min)/256ms (typ)
 - Option ABA: 17ms (min)/32ms (typ)
 - Available on request: 64ms (typ) and 128ms (typ)
- Internal 5k Ω pull-up resistor
- Operating Temperature -40°C to +105°C
- Monitors external pushbutton override
- Internal switch debounce circuitry
- SOT23-3 package

Typical Operating Circuit

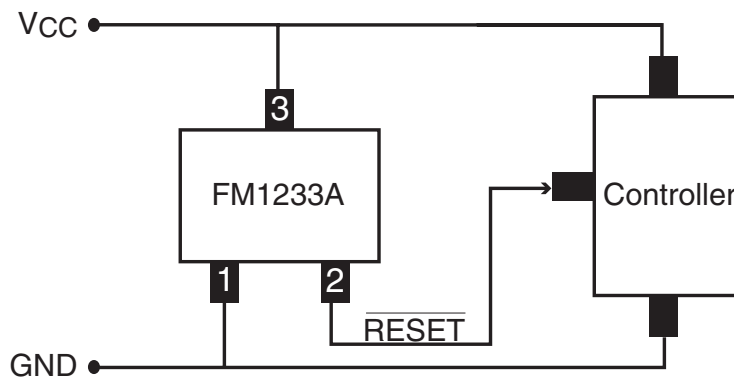

Connection Diagram

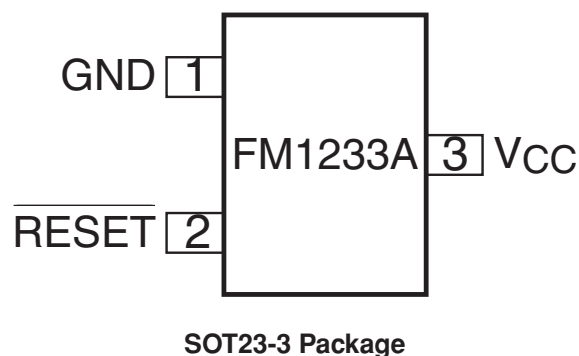

Absolute Maximum Ratings

Voltage on any pin relative to GND		Continuous Power Dissipation ($T_A = 70^\circ\text{C}$)	
V_{CC}	-0.3V to +6.0V	SOT23 (derate 4mW above 70°C)	300mW
$\overline{\text{RESET}}$	-0.3V to ($V_{CC} + 0.3\text{V}$)	Operating Temperature Range	-40°C to +105°C
Input Current	20mA	Storage Temperature Range	-65°C to +150°C
Output Current (RESET)	20mA	Lead Temperature (soldering, 10s)	+300°C

These are stress ratings only, and functional operation is not implied for these levels or beyond. Exposure to Absolute Maximum Rating conditions for extended periods may affect device reliability.

Electrical Characteristics ($V_{CC} = 3.3\text{V}$; $T_A = -40^\circ\text{C}$ to $+105^\circ\text{C}$ unless otherwise noted) (Note 1)

Parameter	Symbol	Conditions	Min	Typ	Max	Units
Operating Voltage	V_{CC}		1.2	3.3	5.5	V
Supply Current	I_{CC}	$V_{CC} < 3.3\text{V}$		3	6	μA
Reset Threshold	V_{TH}	FM1233AC	2.70	2.88	2.97	V
Reset Threshold	V_{TH}	FM1233AD	2.58	2.72	2.86	V
Reset Threshold	V_{TH}	FM1233ABA	2.97	3.08	3.19	V
Reset Output Voltage	V_{OL}				0.4	V
						$I_{SINK} = 1.2\text{mA}$ $V_{CC} = V_{TH(\text{min})}$
Reset Timeout Period	t_{RST}	FM1233AC, FM1233AD	140	256	560	ms
Reset Timeout Period	t_{RST}	FM1233ABA	17	32	64	ms
Pushbutton Detect	PBV_{DET}		0.8		2.0	V
						$V_{CC} = 3.3\text{V}$
Pushbutton Release	PBV_{REL}			0.3	1.5	V
						Note 2

Note 1: Testing at production is done at 25°C only. Limits over temperature are guaranteed by design.

Note 2: $C = 100\text{pF}$, $V_{CC} = 3.3\text{V}$. It is recommended to connect 100pF capacitor between the Reset pin and Ground pin if pushbutton reset is implemented.

Typical Operating Characteristics

Supply Current Vs. Temperature

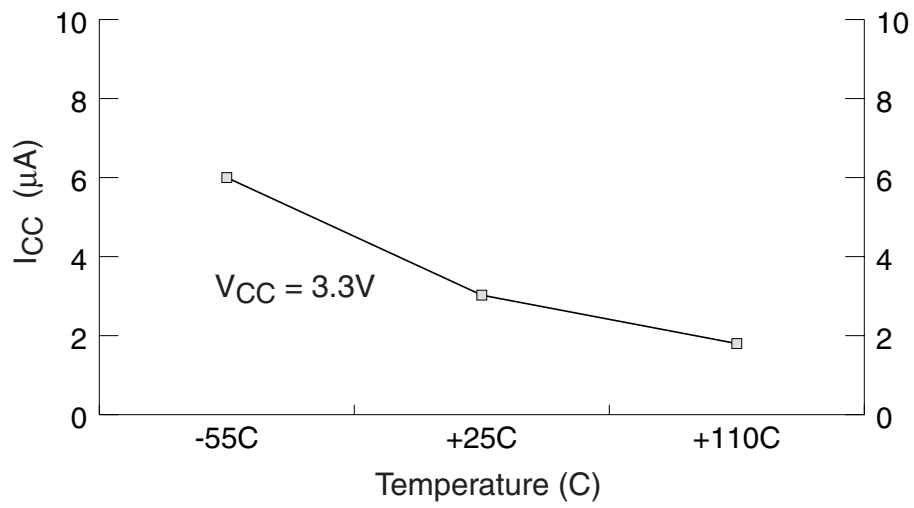

Power up Reset Timeout Vs. Temperature

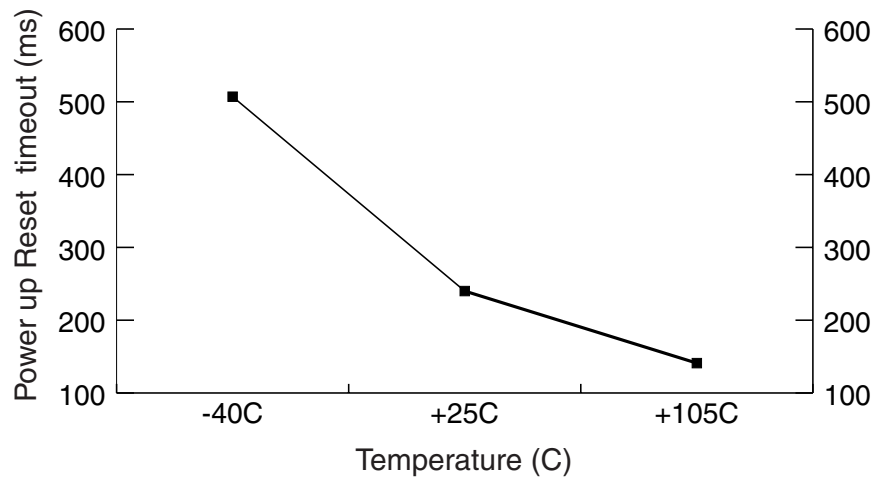

Pin Descriptions

Pin Number	Name	Function
1	GND	GROUND
2	RESET	RESET remains LOW while V_{CC} is below V_{TH} , and for at least the minimum Reset Timeout period after V_{CC} rises above V_{TH} .
3	V_{CC}	

Circuit Timing (Ex: FM1233A)

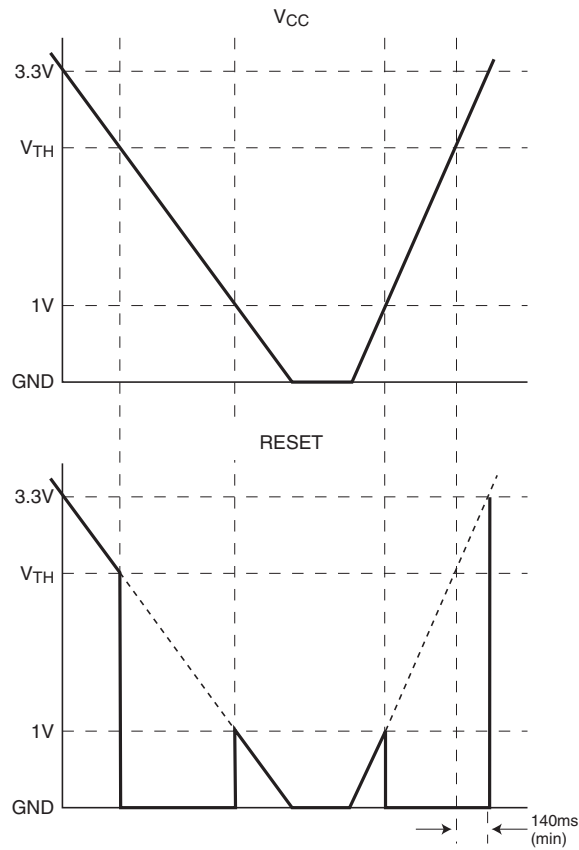

When operating properly with 3V V_{CC} (for example), $\overline{\text{RESET}}$ will also be about 3V. When V_{CC} starts to fall, $\overline{\text{RESET}}$ will follow it down as shown. When V_{CC} drops below V_{TH} , $\overline{\text{RESET}}$ drops to ground ("issues a RESET") and stays there unless V_{CC} also falls below its minimum operating voltage, approx. 1V. At this point, the supervisor loses control, and its output may rise, only to again follow V_{CC} down to the ground.

When V_{CC} begins to rise, $\overline{\text{RESET}}$ follows it until 1.0V or so is reached, whereupon the device regains control, $\overline{\text{RESET}}$ is pulled to ground, etc. When V_{CC} rises above V_{TH} , $\overline{\text{RESET}}$ comes out of RESET after the minimum Reset Timeout period.

If it is required that a lower value than $\text{GND} + 1.0\text{V}$ is needed on RESET signal during $V_{CC} \leq 1\text{V}$, a 100K resistor may be used on the device output to GND.

General Description

The FM1233A features a highly accurate voltage reference to which V_{CC} is compared. Once V_{CC} is below the specified threshold, it will drive the $\overline{\text{RESET}}$ line and continue to hold it low until V_{CC} returns above the threshold and the time for the RESET pulse duration has expired. The FM1233A is immune to short negative going transients on the V_{CC} line. The placement of a $0.1\mu\text{F}$ bypass capacitor as close as possible to the V_{CC} pin provides additional transient immunity.

For a V_{CC} value below 1.0V, the FM1233A does not sink very much current on the $\overline{\text{RESET}}$ pin. This is not a problem in most systems since common devices are not functional in this range. If it is desired for the FM1233A reset to be functional below this range, use a $100\text{k}\Omega$ pull-down resistor between $\overline{\text{RESET}}$ and V_{SS} .

Bi-Directional Reset

The FM1233A permits a pushbutton (or a signal) to initiate a reset externally. Once this external reset is detected on the reset pin, FM1233A also actively asserts the reset signal to maintain the Reset Timeout period when the external reset is not present.

FM1233 internally debounces glitches seen during a typical push button closure. For proper operation, the external switch should be paralleled by an external capacitor of 100pF to $0.01\mu\text{F}$.

Connecting an External Reset to the FM1233A

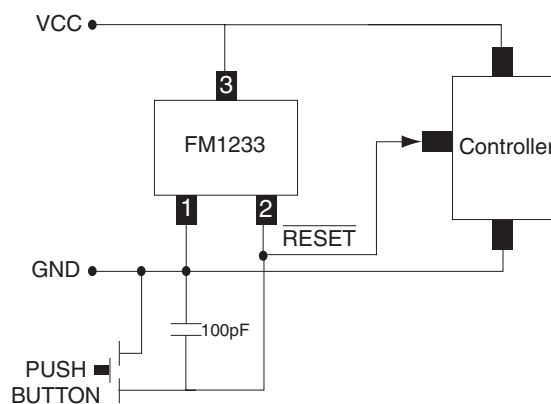

Ordering Information

Part Number	Top Marking	RESET Threshold (V)	Output Type	Package Type	Packing Method
FM1233ACS3X	33AC	2.88	Open-Drain, active LOW	3-Pin, SOT23	3000 units in T&R
FM1233ADS3X	33AD	2.72	Open-Drain, active LOW	3-Pin, SOT23	3000 units in T&R
FM1233ABAS3X	3ABA	3.08	Open-Drain, active LOW	3-PIN, SOT23	3000 units in T&R

Note 3: FM1233AC and FM1233AD feature 256ms (typ) Reset timeout while FM1233ABA features 32ms (typ) Reset Timeout. Consult Fairchild Sales for other reset pulse width options.

Physical Dimensions inches (millimeters) unless otherwise noted

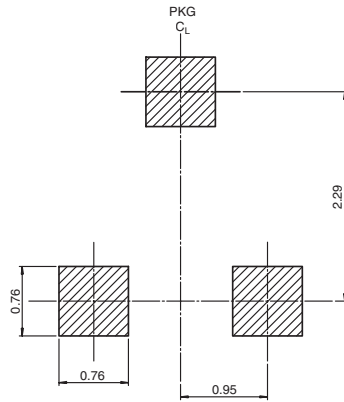
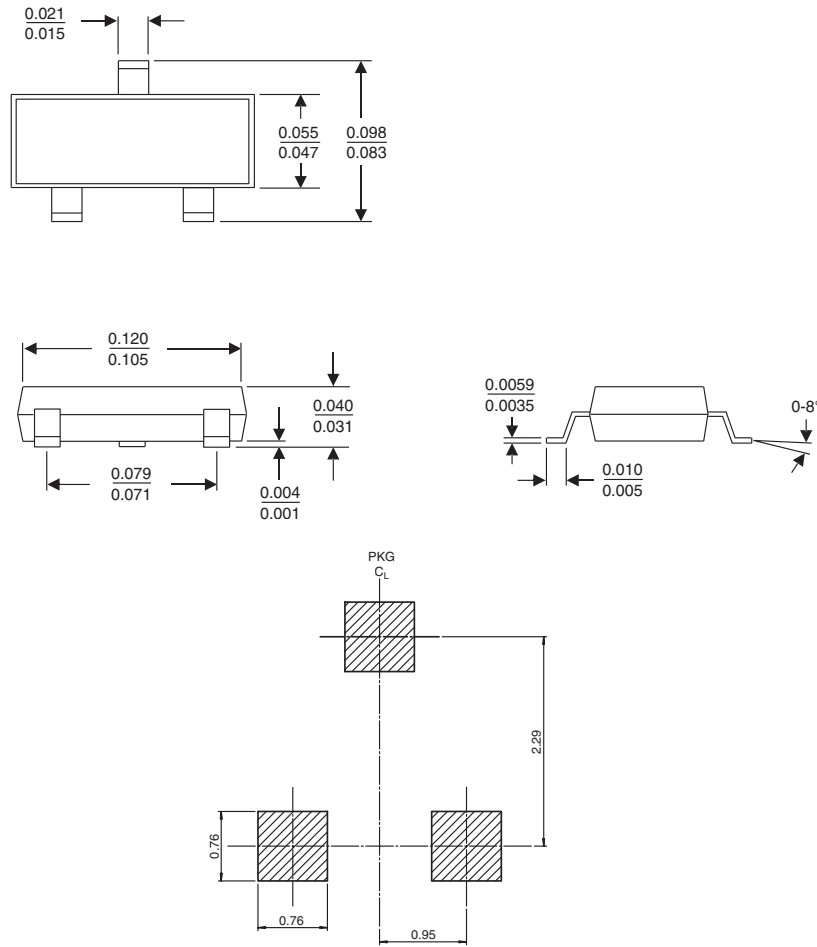

SOT-23 Package Dimensions
FS Pkg Code AU

Life Support Policy

Fairchild's products are not authorized for use as critical components in life support devices or systems without the express written approval of the President of Fairchild Semiconductor Corporation. As used herein:

1. Life support devices or systems are devices or systems which, (a) are intended for surgical implant into the body, or (b) support or sustain life, and whose failure to perform, when properly used in accordance with instructions for use provided in the labeling, can be reasonably expected to result in a significant injury to the user.
2. A critical component is any component of a life support device or system whose failure to perform can be reasonably expected to cause the failure of the life support device or system, or to affect its safety or effectiveness.

Fairchild Semiconductor Americas Customer Response Center
Tel: 1-888-522-5372

Fairchild Semiconductor Europe
 Fax: +44 (0) 1793-856858
 Deutsch Tel: +49 (0) 8141-6102-0
 English Tel: +44 (0) 1793-856856
 Français Tel: +33 (0) 1-6930-3696
 Italiano Tel: +39 (0) 2-249111-1

Fairchild Semiconductor Hong Kong
 8/F, Room 808, Empire Centre
 68 Mody Road, Tsimshatsui East
 Kowloon, Hong Kong
 Tel: +852-2722-8338
 Fax: +852-2722-8383

Fairchild Semiconductor Japan Ltd.
 4F, Natsume Bldg.
 2-18-6, Yushima, Bunkyo-ku
 Tokyo, 113-0034 Japan
 Tel: 81-3-3818-8840
 Fax: 81-3-3818-8841