

L272 • L272A Dual Power Operational Amplifier

General Description

The L272 and L272A are high-power dual operational amplifier provided as a 8-DIP and 16-SOP package. The operational amplifier is designed for low impedance loads and will deliver output current up to 0.7A. The L272A offers tighter specifications for input bias current, input offset voltage and input offset currents. The L272 and L272A can be used in a wide range of applications including power supply, VCR, monitor, servo amplifier, compact disc, etc.

Features

- Output Current up to 0.7A
- Operates at Low Voltage ($V_{S(MIN)} = 4V$)
- Low Saturation Voltage ($I_p = 0.5A, V_O = 1.5V$)
- Thermal Shutdown (TSD = 160°C) Ground Compatible Inputs
- Ground Compatible Inputs
- Large Common Mode & Differential Mode Range

Applications

- Servo Amplifier
- Power Supply
- Compact Disc
- VCR
- Monitor

Ordering Code:

Product Number	Package	Packing	Operating Temperature
L272M	8-DIP	Tube	-25°C to +85°C
L272D2	16-SOP	Tube	
L272D2TF	16-SOP	Tape and Reel	
L272AM	8-DIP	Tube	
L272AD2	16-SOP	Tube	
L272AD2TF	16-SOP	Tape and Reel	

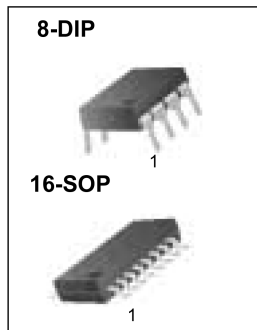

Internal Block Diagram

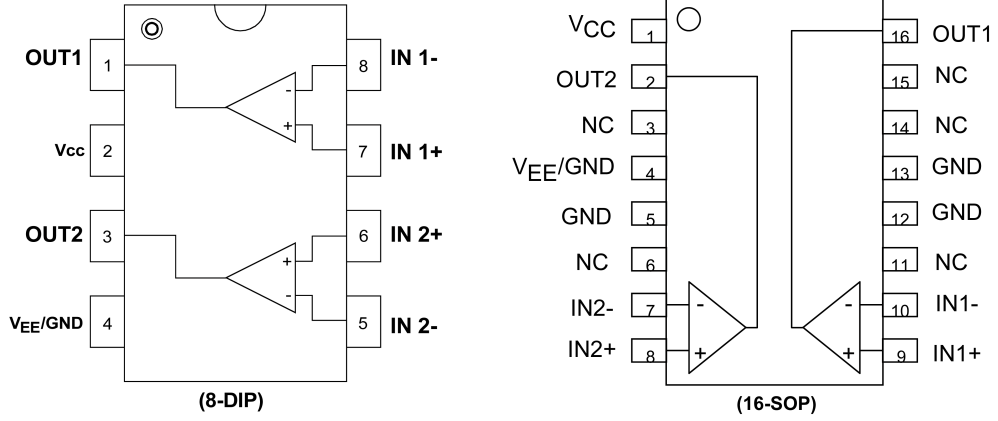

Pin Definitions

Pin Number		Pin Name	Pin Function Description
8-DIP	16-SOP		
1	16	OUTPUT1	Amp Output 1
2	1	V _{CC}	Positive Supply Voltage
3	2	OUTPUT2	Amp Output 2
4	4/5/12/13	V _{EE} /GND	Negative Supply Voltage (GND)
5	7	INPUT-2	Amp Negative Input 2
6	8	INPUT+2	Amp Positive Input 2
7	9	INPUT+1	Amp Positive Input 1
8	10	INPUT-1	Amp Negative Input 1

Absolute Maximum Ratings ^(Note 1)			
Parameter	Symbol	Value	Units
Supply Voltage	V_{CC}	40	V
Input Voltage	V_I	V_S	V
Differential Input Voltage	$V_{I(DIFF)}$	$\pm V_S$	V
DC Output Current	I_O	0.7	A
Peak Output Current (Non Repetitive)	I_P	1	A
Power Dissipation At: $T_{amb} = 50^\circ\text{C}$	P_{tot}	1	W
Operating Temperature Range	T_{op}	-25 to 85	$^\circ\text{C}$
Storage and Junction Temperature	T_{stg}, T_j	-40 to 150	$^\circ\text{C}$

Thermal Data			
Parameter	Symbol	Value	Unit
Thermal Resistance Junction-Ambient Maximum	$R\theta_{ja}$	100	$^\circ\text{C}/\text{W}$
8-DIP			
16-SOP			

Note 1: The "Absolute Maximum Ratings" are those values beyond which the safety of the device cannot be guaranteed. The device should not be operated at these limits. The parametric values defined in the Electrical Characteristics tables are not guaranteed at the absolute maximum ratings.

Electrical Characteristics (L272)

($V_{CC} = +12\text{V}$, $V_{EE} = -12\text{V}$, $T_A = 25^\circ\text{C}$ unless otherwise specified)

Parameter	Symbol	Conditions	Min	Typ	Max	Units
Supply Voltage ($V_{CC} - V_{EE}$)	V_S		4.0		28.0	V
Supply Current	I_S	$V_O = V_{CC}/2$ $V_{CC} = 24\text{V}, V_{EE} = 0\text{V}$ $V_{CC} = 12\text{V}, V_{EE} = 0\text{V}$		8.0 7.5	12.0 11.0	mA mA
Input Bias Current	I_{BIAS}			0.3	2.5	μA
Input Offset Voltage	V_{IO}			15.0	60.0	mV
Input Offset Current	I_{IO}			50.0	250	nA
Slew Rate	SR	$V_{IN} = 1V_{pp}$, Unit Gain		1.0		V/ μs
Gain-Bandwidth Product	GBW			350		kHz
Input Resistance	R_I		500			k Ω
Large Signal	G_V	$V_{O(pp)} = \pm 10\text{V}$	65.0	75.0		dB
Input Noise Voltage	e_N	$B = 20\text{ kHz}$		10.0		μV
Input Noise Current	I_N	$B = 20\text{ kHz}$		200		pA
Common Mode Rejection Ratio	CMRR		60.0	75.0		dB
Supply Voltage Rejection Ratio	PSRR	$V_{CC} = +15\text{V}, V_{EE} = -15\text{V}$ $V_{CC} = +5\text{V}, V_{EE} = -5\text{V}$	54.0	62.0		dB
Output Voltage Swing	V_O	$V_{CC} = 24\text{V}, V_{EE} = 0\text{V}$ $I_P = 0.1\text{A}$ $I_P = 0.5\text{A}$	21.0 21.0	23.0 22.5		V V
Channel Separation	C_S	$f = 1\text{ kHz}; R_L = 10\Omega, G_V = 30\text{ dB}$		60.0		dB
Total Harmonic Distortion	THD	$f = 1\text{ kHz}; G_V = 1\text{ dB}, R_L = \bullet$		0.5		%
Thermal Shutdown Temperature (Note 2)	TSD			160		$^\circ\text{C}$

Note 2: Guaranteed by design. Not 100% tested in production.

Electrical Characteristics (L272A)(V_{CC} = +12V, V_{EE} = -12V, T_A = 25°C unless otherwise specified)

Parameter	Symbol	Conditions	Min	Typ	Max	Units
Supply Voltage (V _{CC} - V _{EE})	V _S		4.0		28.0	V
Supply Current	I _S	V _O = V _{CC} /2		8.0	12.0	mA
		V _{CC} = 24V, V _{EE} = 0V		7.5	11.0	mA
		V _{CC} = 12V, V _{EE} = 0V				
Input Bias Current	I _{BIAS}			0.1	1.0	μA
Input Offset Voltage	V _{IO}			7.0	30.0	mV
Input Offset Current	I _{IO}			20.0	100	nA
Slew Rate	SR	V _{IN} = 1V _{PP} , Unit Gain		1.0		V/μs
Gain-Bandwidth Product	GBW			350		kHz
Input Resistance	R _I		500			kΩ
Large Signal	G _V	V _{O(pp)} = ± 10V	65.0	75.0		dB
Input Noise Voltage	e _N	B = 20 kHz		10.0		μV
Input Noise Current	I _N	B = 20 kHz		200		pA
Common Mode Rejection Ratio	CMRR		60.0	75.0		dB
Supply Voltage Rejection Ratio	PSRR	V _{CC} = +15V, V _{EE} = -15V V _{CC} = +5V, V _{EE} = -5V	54.0	62.0		dB
Output Voltage Swing	V _O	V _{CC} = 24V, V _{EE} = 0V I _P = 0.1A	21.0	23.0		V
		I _P = 0.5A	21.0	22.5		V
Channel Separation	C _S	f = 1 kHz; R _L = 10Ω, G _V = 30 dB		60.0		dB
Total Harmonic Distortion	THD	f = 1 kHz; G _V = 1dB, R _L = •		0.5		%
Thermal Shutdown Temperature (Note 2)	TSD			160		°C

Note 3: Guaranteed by design. Not 100% tested in production.

Typical Performance Characteristics

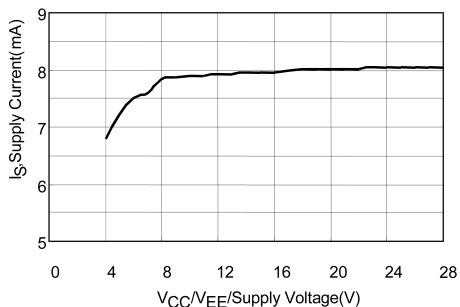

FIGURE 1. Supply Voltage vs. Supply Current with No Load

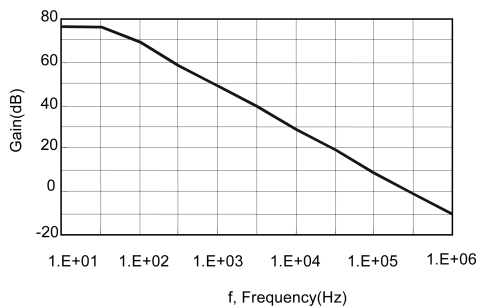

FIGURE 2. Open Loop Voltage Gain

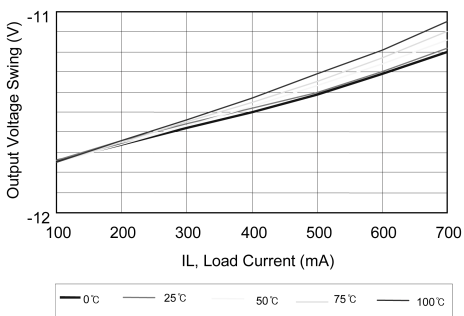

FIGURE 3. Output voltage Swing vs. Load Current

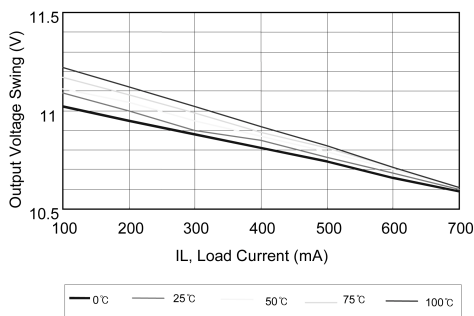

FIGURE 4. Output Voltage Swing vs. Load Current

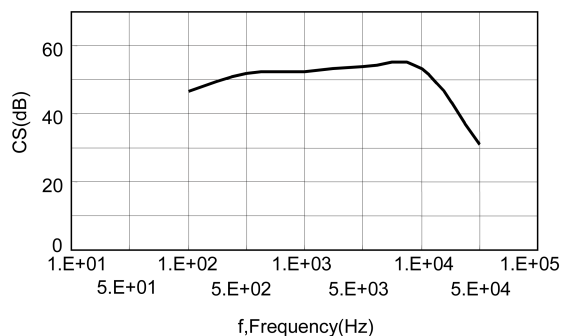
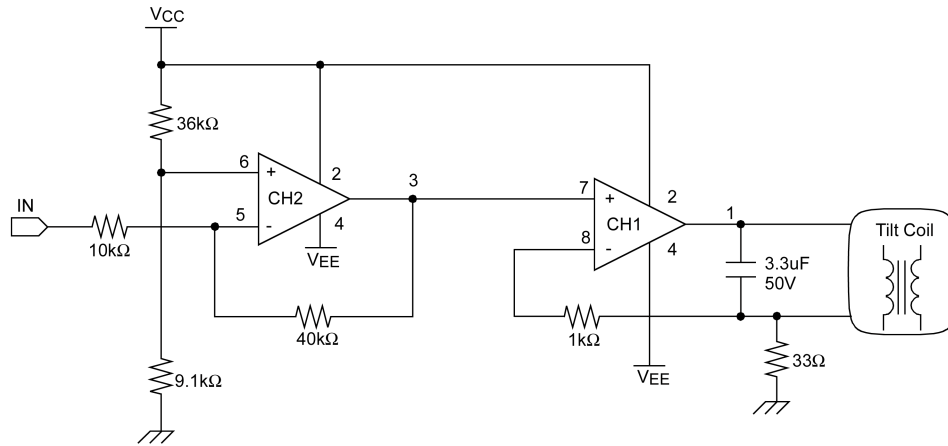

FIGURE 5. Channel Separation vs. Frequency

Application



<Tilt Coil Current Circuit in Monitor, 8-DIP Package>

Physical Dimensions inches (millimeters) unless otherwise noted

L272 • L272A

Package

Dimensions in millimeters

8-DIP

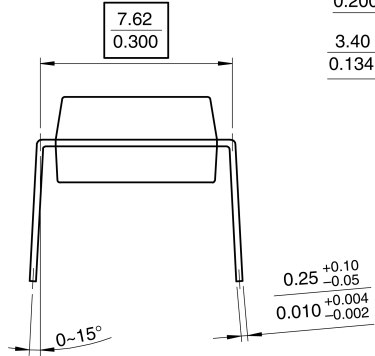
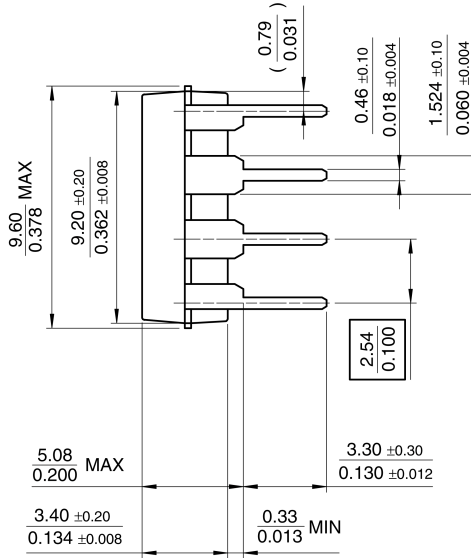
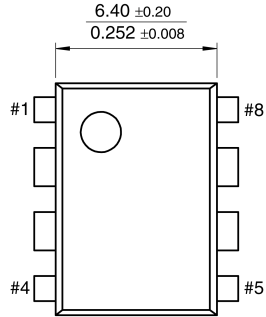

Physical Dimensions inches (millimeters) unless otherwise noted (Continued)

Package

Dimensions in millimeters

16-SOP

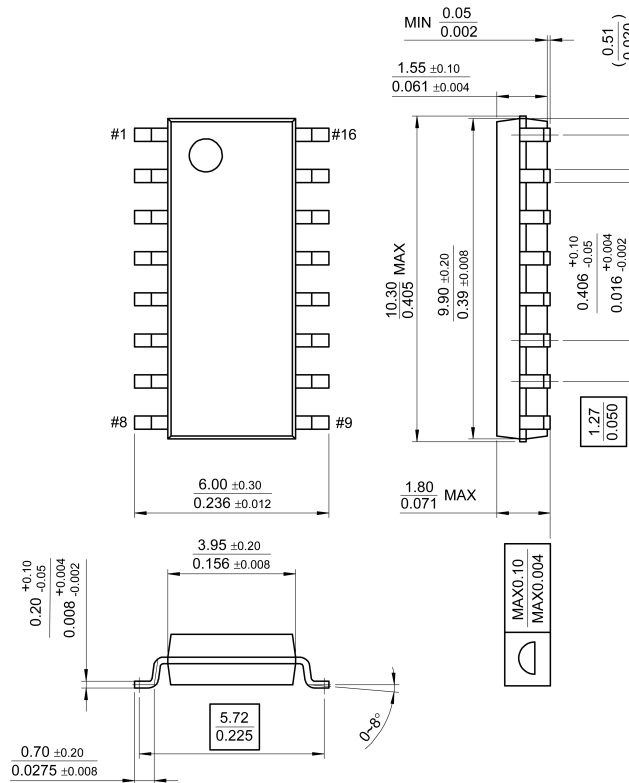

Fairchild does not assume any responsibility for use of any circuitry described, no circuit patent licenses are implied and Fairchild reserves the right at any time without notice to change said circuitry and specifications.

LIFE SUPPORT POLICY

FAIRCHILD'S PRODUCTS ARE NOT AUTHORIZED FOR USE AS CRITICAL COMPONENTS IN LIFE SUPPORT DEVICES OR SYSTEMS WITHOUT THE EXPRESS WRITTEN APPROVAL OF THE PRESIDENT OF FAIRCHILD SEMICONDUCTOR CORPORATION. As used herein:

1. Life support devices or systems are devices or systems which, (a) are intended for surgical implant into the body, or (b) support or sustain life, and (c) whose failure to perform when properly used in accordance with instructions for use provided in the labeling, can be reasonably expected to result in a significant injury to the user.
2. A critical component in any component of a life support device or system whose failure to perform can be reasonably expected to cause the failure of the life support device or system, or to affect its safety or effectiveness.

www.fairchildsemi.com