

Description

The ATWINC1500-MR210PB is a low-power consumption 802.11 b/g/n IoT (Internet of Things) module, which is specifically optimized for low power IoT applications. The highly integrated module features small form factor (21.5mm x 14.5mm x 2.1mm) while fully integrating Power Amplifier, LNA, Switch, Power Management, and PCB antenna. With seamless roaming capabilities and advanced security, it could be interoperable with various vendors' 802.11b/g/n Access Points in wireless LAN. The module provides SPI and UART to interface to host controller.

Features

- IEEE® 802.11 b/g/n 20MHz (1x1) solution
- Single spatial stream in 2.4GHz ISM band
- Integrated PA and T/R Switch
- Integrated PCB antenna
- Superior Sensitivity and Range via advanced PHY signal processing
- Advanced Equalization and Channel Estimation
- Advanced Carrier and Timing Synchronization
- Wi-Fi Direct and Soft-AP support
- Supports IEEE 802.11 WEP, WPA, WPA2 Security
- Supports China WAPI security
- Superior MAC throughput via hardware accelerated two-level A-MSDU/A-MPDU frame aggregation and block acknowledgement
- On-chip memory management engine to reduce host load
- SPI, UART, and I²C host interfaces
- 2- or 3-wire Bluetooth® coexistence interface
- Operating temperature range of -40°C to +85°C
- I/O operating voltage of 2.7V to 3.6V
- Integrated Flash memory for system software
- Power Save Modes
 - <4µA Power Down mode typical @3.3V I/O
 - 380µA Doze mode with chip settings preserved (used for beacon monitoring)¹

¹See [Power Consumption](#) for module power modes.

- On-chip low power sleep oscillator
 - Fast host wake-up from Doze mode by a pin or SPI transaction
- Fast Boot Options
 - On-chip Boot ROM (Firmware instant boot)
 - SPI flash boot (firmware patches and state variables)
 - Low-leakage on-chip memory for state variables
 - Fast AP Re-Association (150ms)
- On-Chip Network Stack to offload MCU
 - Integrated Network IP stack to minimize host CPU requirements
 - Network features TCP, UDP, DHCP, ARP, HTTP, SSL, and DNS
- Hardware accelerators for Wi-Fi and SSL security to improve connection time
- Hardware accelerator for IP checksum
- Hardware accelerators for OTA security
- Small footprint host driver (4KB flash – less than 1KB RAM)

Table of Contents

1	Ordering Information and Module Marking	5
2	Block Diagram	6
3	Pinout Information	7
3.1	Pin Description	7
3.2	Module Outline Drawing	9
4	Electrical Specifications	10
4.1	Absolute Ratings	10
4.2	Recommended Operating Conditions	10
5	CPU and Memory Subsystems	11
5.1	Processor	11
5.2	Memory Subsystem	11
5.3	Non-volatile Memory (eFuse)	11
6	WLAN Subsystem	12
6.1	MAC	12
6.1.1	Features	12
6.1.2	Description	12
6.2	PHY	13
6.2.1	Features	13
6.2.2	Description	13
6.3	Radio	13
6.3.1	Receiver Performance	14
6.3.2	Transmitter Performance	15
7	External Interfaces	16
7.1	SPI Interface	16
7.1.1	Overview	16
7.1.2	SPI Timing	16
7.2	UART Interface	18
7.3	Wi-Fi/Bluetooth Coexistence	18
8	Power Consumption	19
8.1	Description of Device States	19
8.2	Current Consumption in Various Device States	19
8.3	Restrictions for Power States	20
8.4	Power-up/down Sequence	20
8.5	Digital I/O Pin Behavior During Power-up Sequences	21
9	Notes On Interfacing to the ATWINC1500-MR210PB	22
9.1	Programmable Pull-up Resistors	22
10	RF Performance Placement Guidelines	22
11	Schematic Design Information	23
11.1	Application Schematic	23
12	Reflow Profile Information	24

12.1	Storage Condition.....	24
12.1.1	Moisture Barrier Bag Before Opened	24
12.1.2	Moisture Barrier Bag Open	24
12.2	Stencil Design	24
12.3	Baking Conditions	24
12.4	Soldering and Reflow Condition	24
12.4.1	Reflow Oven	24
13	Reference Documentation and Support.....	26
13.1	Reference Documents.....	26
14	Revision History	27

1 Ordering Information and Module Marking

Table 1-1. Ordering Details

Ordering code	Package	Description
ATWINC1500-MR210PB	22x15mm	Certified module with ATWINC1500B chip and PCB antenna
ATWINC1500-MR210UB	22x15mm	Certified module with ATWINC1500B chip and uFL connector
ATWINC1510-MR210PB	22x15mm	Certified module with ATWINC1510B chip (8Mb Flash) and PCB antenna

Figure 1-1. Marking Information

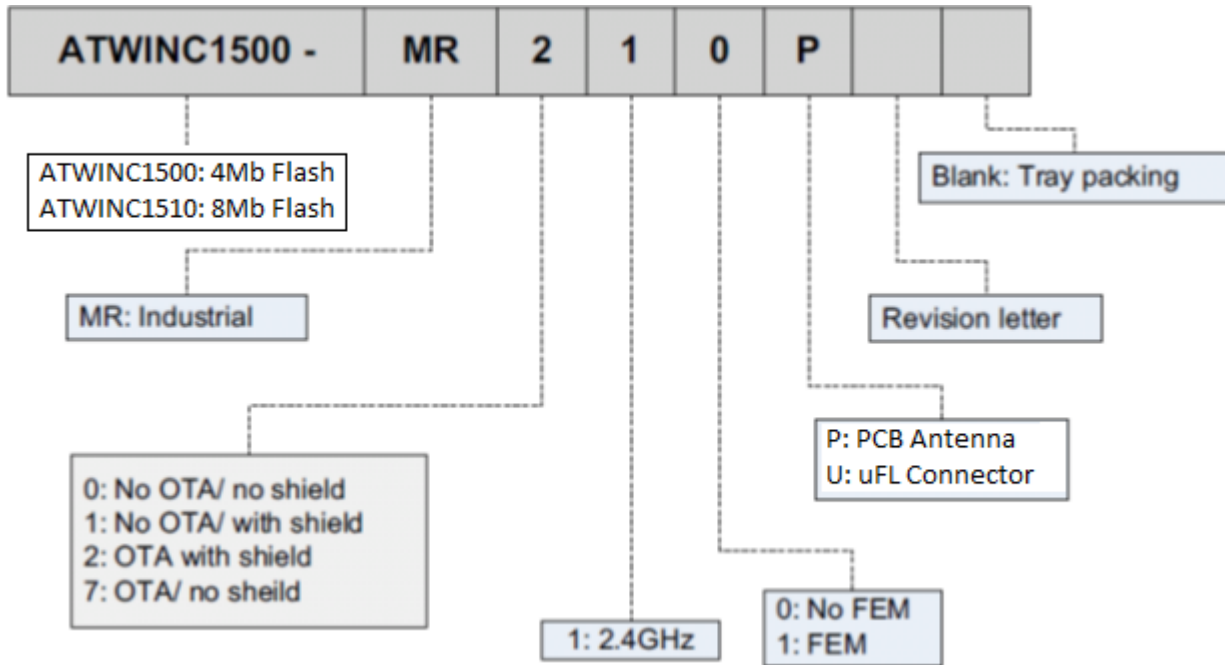

2 Block Diagram

Figure 2-1. Block Diagram of the Module

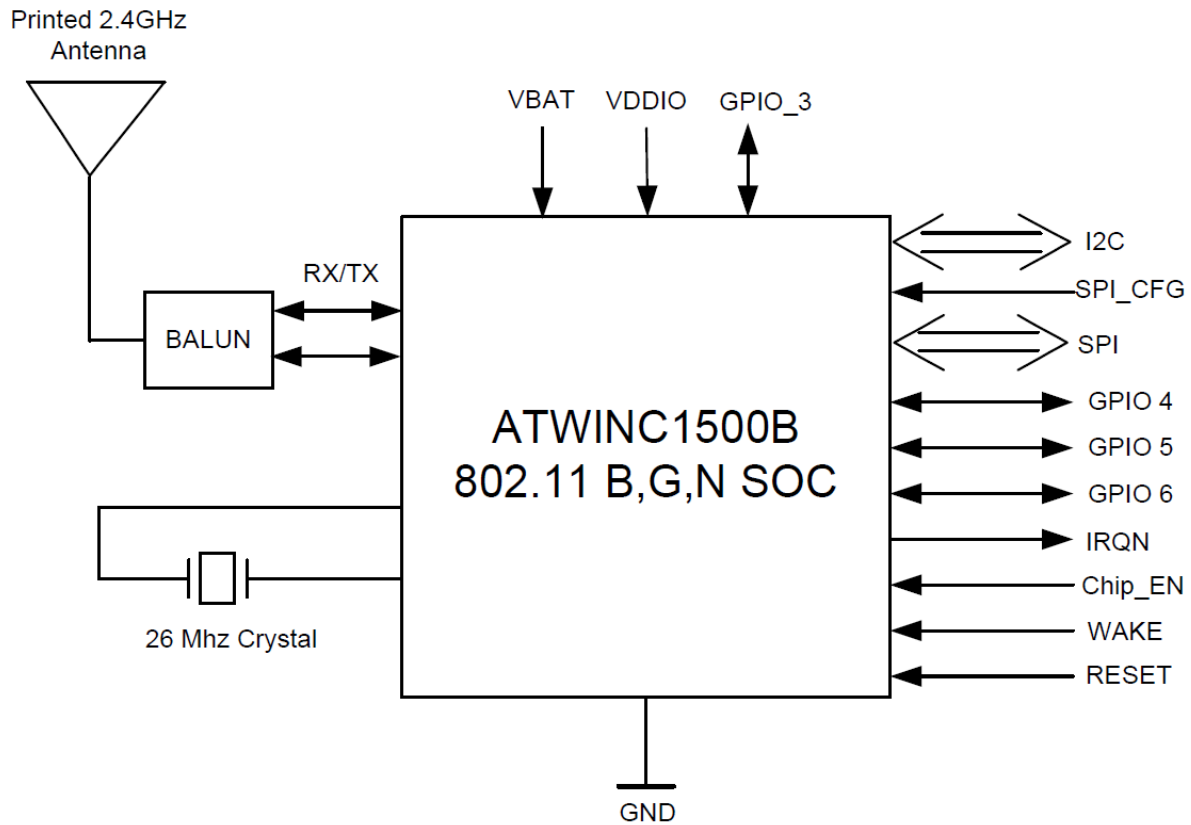

3 Pinout Information

3.1 Pin Description

Figure 3-1. Pin Assignment

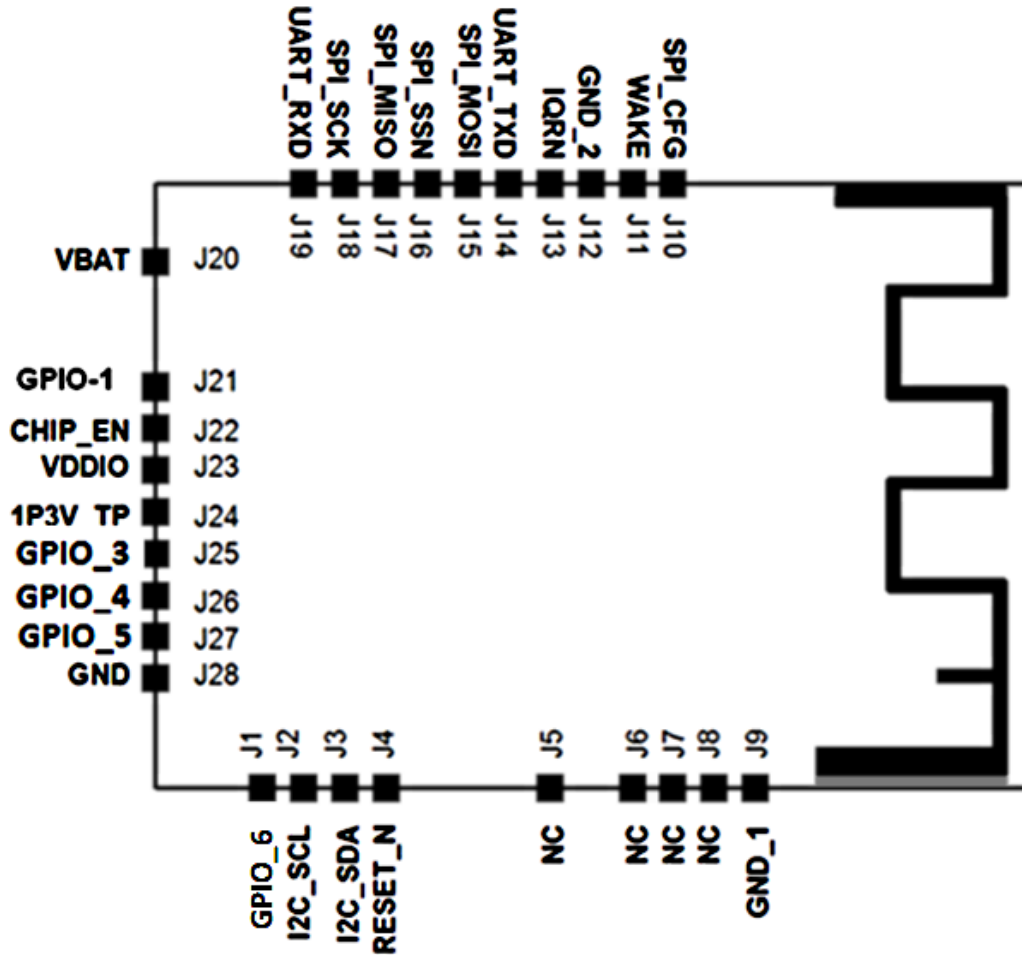

Table 3-1. Pin Description

NO	Name	Type	Description	Programmable pull-up resistor
1	GPIO_6	I/O	General purpose I/O	Yes
2	I2C_SCL	I/O	I ² C Slave Clock. Currently used only for Atmel debug. Not for customer use. Leave unconnected.	Yes
3	I2C_SDA	I/O	I ² C Slave Data. Currently used only for Atmel debug. Not for customer use. Leave unconnected.	Yes
4	RESET_N	I	Active-Low Hard Reset. When asserted to a low level, the module will be placed in a reset state. When asserted to a high level, the module will run normally. Connect to a host output that defaults low at power up. If the host output is tri-stated, add a 1M Ω pull-down resistor to ensure a low level at power up.	No
5	NC	-	No connect	

NO	Name	Type	Description	Programmable pull-up resistor
6	NC	-	No connect	
7	NC	-	No connect	
8	NC	-	No connect	
9	GND_1	-	GND	
10	SPI_CFG	I	Tie to VDDIO through a 1M Ω resistor to enable the SPI interface	No
11	WAKE	I	Host Wake control. Can be used to wake up the module from Doze mode. Connect to a host GPIO.	Yes
12	GND_2	-	GND	
13	IRQN	O	ATWINC1500-MR210P Device Interrupt output. Connect to host interrupt input pin.	Yes
14	UART_TXD	O	UART Transmit Output from ATWINC1500-MR210P	Yes
15	SPI_RXD	I	SPI MOSI (Master Out Slave In) pin	Yes
16	SPI_SSN	I	SPI Slave Select. Active low	Yes
17	SPI_TXD	O	SPI MISO (Master In Slave Out) pin	Yes
18	SPI_SCK	I	SPI Clock	Yes
19	UART_RXD	I	UART Receive input to ATWINC1500-MR210P	Yes
20	VBATT	-	Battery power supply	
21	GPIO_1/RTC	I	General Purpose I/O / RTC	Yes
22	CHIP_EN	I	Module enable. High level enables module, low level places module in Power Down mode. Connect to a host Output that defaults low at power up. If the host output is tri-stated, add a 1M Ω pull-down resistor to ensure a low level at power up.	No
23	VDDIO	-	I/O Power Supply. Must match host I/O voltage.	
24	1P3V_TP	-	1.3V VDD Core Test Point. Leave unconnected.	
25	GPIO_3	I/O	General purpose I/O	
26	GPIO_4	I/O	General purpose I/O	Yes
27	GPIO_5	I/O	General purpose I/O	Yes
28	GND_3	-	GND	
29	PADDLE	-	GND	

3.2 Module Outline Drawing

Figure 3-2. Module Drawings – ATWINC1500-MR210PB - Top and Bottom Views (unit = mm)

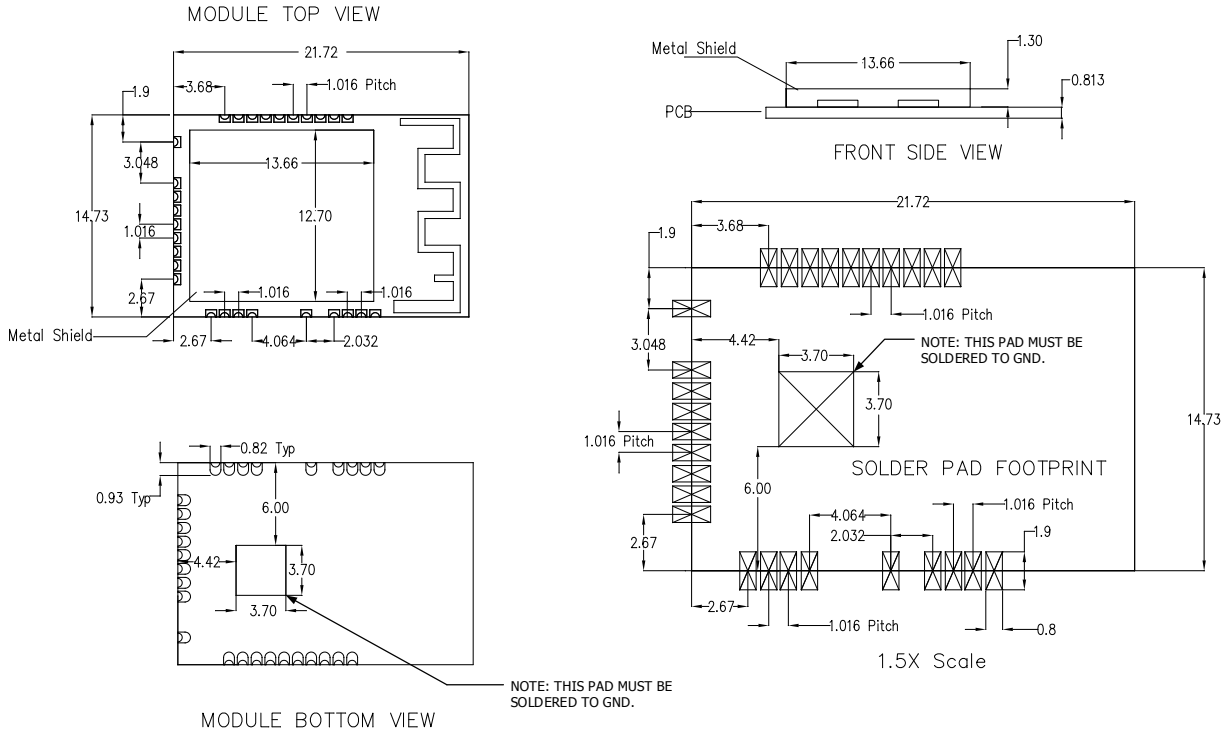
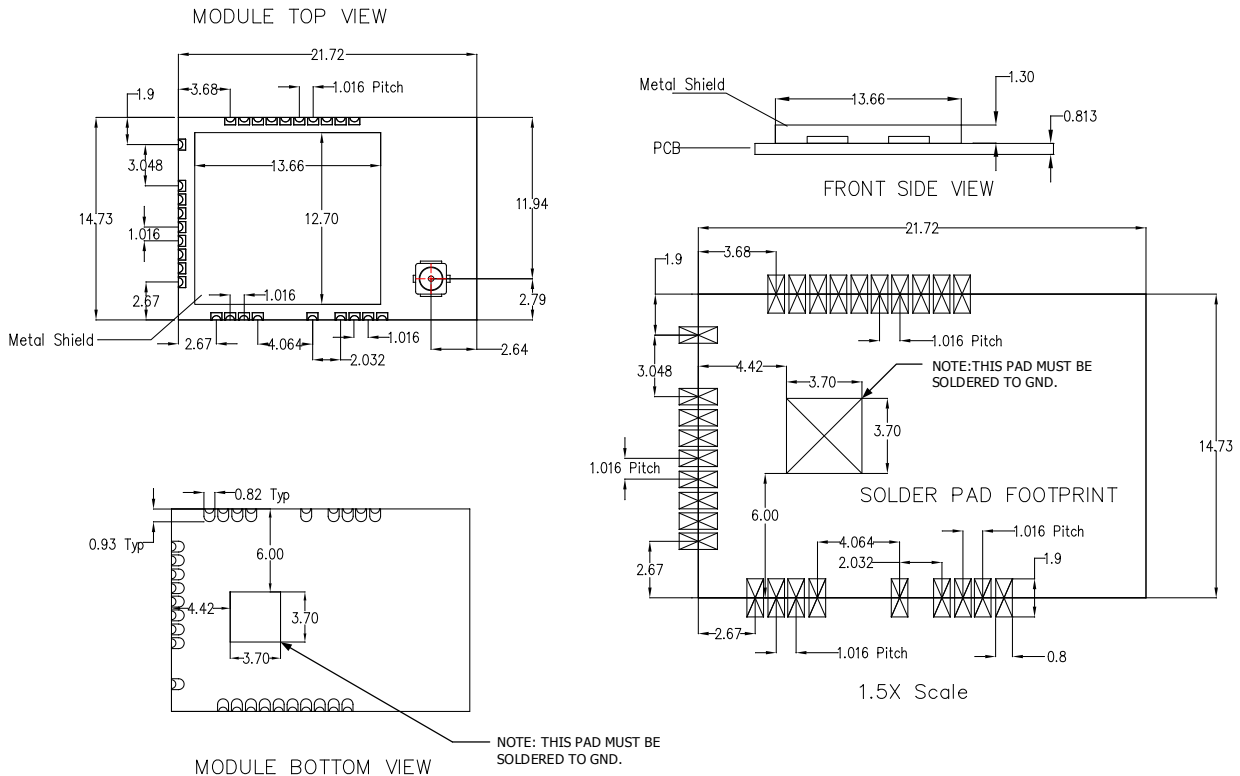

Figure 3-3. Module Drawings – ATWINC1500-MR210UB - Top and Bottom Views (unit = mm)



4 Electrical Specifications

4.1 Absolute Ratings

Table 4-1. Voltages

Symbol	Description	Min.	Max.	Unit
VBATT	Input supply voltage	-0.3	5.0	V
VDDIO	I/O voltage	-0.3	4.6	V

4.2 Recommended Operating Conditions

Table 4-2. Recommended Operating Conditions

Test conditions: -40°C - +85°C				
Symbol	Min.	Typ.	Max.	Unit
VBATT	3.0	3.6	4.2	V
VDDIO	2.7	3.3	3.6	V

5 CPU and Memory Subsystems

5.1 Processor

ATWINC1500B has a Cortus APS3 32-bit processor. This processor performs many of the MAC functions, including but not limited to association, authentication, power management, security key management, and MSDU aggregation/de-aggregation. In addition, the processor provides flexibility for various modes of operation, such as STA and AP modes.

5.2 Memory Subsystem

The APS3 core uses a 128KB instruction/boot ROM along with a 160KB instruction RAM and a 64KB data RAM. ATWINC1500B also has 4Mb of flash memory, which can be used for system software. In addition, the device uses a 128KB shared RAM, accessible by the processor and MAC, which allows the APS3 core to perform various data management tasks on the TX and RX data packets.

5.3 Non-volatile Memory (eFuse)

ATWINC1500B has 768 bits of non-volatile eFuse memory that can be read by the CPU after device reset. This non-volatile one-time-programmable (OTP) memory can be used to store customer-specific parameters, such as MAC address; various calibration information, such as TX power, crystal frequency offset, etc.; and other software-specific configuration parameters. The eFuse is partitioned into six 128-bit banks. Each bank has the same bit map, which is shown in Figure 5-1. The purpose of the first 80 bits in each bank is fixed, and the remaining 48 bits are general-purpose software dependent bits, or reserved for future use. Since each bank can be programmed independently, this allows for several updates of the device parameters following the initial programming, e.g. updating MAC address. Refer to ATWINC1500-MR210PB Programming Guide for the eFuse programming instructions.

Figure 5-1. eFuse Bit Map

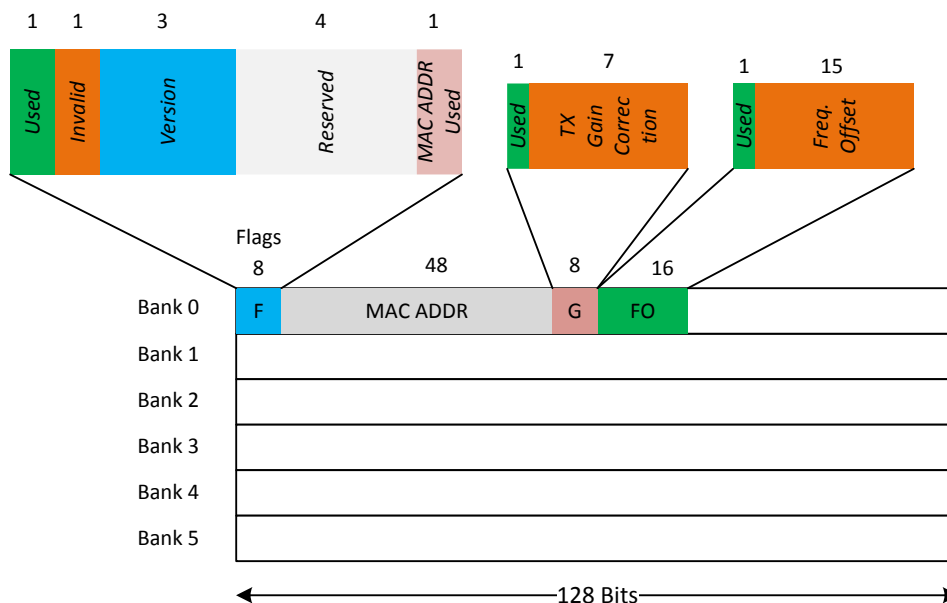

6 WLAN Subsystem

The WLAN subsystem is composed of the Media Access Controller (MAC) and the Physical Layer (PHY). The following two subsections describe the MAC and PHY in detail.

6.1 MAC

6.1.1 Features

The ATWINC1500-MR210PB IEEE802.11 MAC supports the following functions:

- IEEE 802.11b/g/n
- IEEE 802.11e WMM QoS EDCA/PCF multiple access categories traffic scheduling
- Advanced IEEE 802.11n features:
 - Transmission and reception of aggregated MPDUs (A-MPDU)
 - Transmission and reception of aggregated MSDUs (A-MSDU)
 - Immediate Block Acknowledgement
 - Reduced Interframe Spacing (RIFS)
- Support for IEEE802.11i and WPA security with key management
 - WEP 64/128
 - WPA-TKIP
 - 128-bit WPA2 CCMP (AES)
- Support for WAPI security
- Advanced power management
 - Standard 802.11 Power Save Mode
 - Wi-Fi Alliance WMM-PS (U-APSD)
- RTS-CTS and CTS-self support
- Supports either STA or AP mode in the infrastructure basic service set mode
- Supports independent basic service set (IBSS)

6.1.2 Description

The ATWINC1500B MAC is designed to operate at low power while providing high data throughput. The IEEE 802.11 MAC functions are implemented with a combination of dedicated datapath engines, hardwired control logic, and a low-power, high-efficiency microprocessor. The combination of dedicated logic with a programmable processor provides optimal power efficiency and real-time response while providing the flexibility to accommodate evolving standards and future feature enhancements.

Dedicated datapath engines are used to implement datapath functions with heavy computational requirements. For example, an FCS engine checks the CRC of the transmitting and receiving packets, and a cipher engine performs all the required encryption and decryption operations for the WEP, WPA-TKIP, WPA2 CCMP-AES, and WAPI security requirements.

Control functions which have real-time requirements are implemented using hardwired control logic modules. These logic modules offer real-time response while maintaining configurability via the processor. Examples of hardwired control logic modules are the channel access control module (implements EDCA/HCCA, Beacon TX control, interframe spacing, etc.), protocol timer module (responsible for the Network Access Vector, back-off timing, timing synchronization function, and slot management), MPDU handling module, aggregation/de-aggregation module, block ACK controller (implements the protocol requirements for burst block communication), and TX/RX control FSMs (coordinate data movement between PHY-MAC interface, cipher engine, and the DMA interface to the TX/RX FIFOs).

The MAC functions implemented solely in software on the microprocessor have the following characteristics:

- Functions with high memory requirements or complex data structures. Examples are association table management and power save queuing.
- Functions with low computational load or without critical real-time requirements. Examples are authentication and association.
- Functions which need flexibility and upgradeability. Examples are beacon frame processing and QoS scheduling.

6.2 PHY

6.2.1 Features

The ATWINC1500B IEEE802.11 PHY supports the following functions:

- Single antenna 1x1 stream in 20MHz channels
- Supports IEEE 802.11b DSSS-CCK modulation: 1, 2, 5.5, 11Mbps
- Supports IEEE 802.11g OFDM modulation: 6, 9, 12, 18, 24, 36, 48, 54Mbps
- Supports IEEE 802.11n HT modulations MCS0-7, 20MHz, 800 and 400ns guard interval: 6.5, 7.2, 13.0, 14.4, 19.5, 21.7, 26.0, 28.9, 39.0, 43.3, 52.0, 57.8, 58.5, 65.0, 72.2Mbps
- IEEE 802.11n mixed mode operation
- Per packet TX power control
- Advanced channel estimation/equalization, automatic gain control, CCA, carrier/symbol recovery, and frame detection

6.2.2 Description

The ATWINC1500B WLAN PHY is designed to achieve reliable and power-efficient physical layer communication specified by IEEE 802.11 b/g/n in single stream mode with 20MHz bandwidth. Advanced algorithms have been employed to achieve maximum throughput in a real world communication environment with impairments and interference. The PHY implements all the required functions such as FFT, filtering, FEC (Viterbi decoder), frequency, and timing acquisition and tracking, channel estimation and equalization, carrier sensing and clear channel assessment, as well as the automatic gain control.

6.3 Radio

Table 6-1. Radio Performance under Typical Conditions: VBATT=3.3V; VDDIO=3.3V; temp.: 25°C

Feature	Description
Module Part Number	ATWINC1500-MR210PB
WLAN Standard	IEEE 802.11b/g/n, Wi-Fi compliant
Host Interface	SPI, UART
Dimension	L x W x H: 21.72 x 14.73 x 3.5 (typical) mm
Frequency Range	2.412GHz ~ 2.4835GHz (2.4GHz ISM Band)
Number of Channels	11 for North America, 13 for Europe, and 14 for Japan
Modulation	802.11b: DQPSK, DBPSK, CCK 802.11g/n: OFDM /64-QAM, 16-QAM, QPSK, BPSK
Data Rate	802.11b: 1, 2, 5.5, 11Mbps 802.11g: 6, 9, 12, 18, 24, 36, 48, 54Mbps

Feature	Description
Data Rate (20MHz, normal GI, 800ns)	802.11n: 6.5, 13, 19.5, 26, 39, 52, 58.5, 65Mbps
Data Rate (20MHz, short GI, 400ns)	802.11n: 7.2, 14.4, 21.7, 28.9, 43.3, 57.8, 65,72.2Mbps
Operating temperature	-40°C to 85°C
Storage temperature	-40°C to 85°C
Humidity	Operating Humidity 10% to 95% Non-Condensing Storage Humidity 5% to 95% Non-Condensing

6.3.1 Receiver Performance

Radio performance under typical conditions: VBATT=3.3V; VDDIO=3.3V; temp.: 25°C.

Table 6-2. Receiver Performance

Parameter	Description	Minimum	Typical	Maximum	Unit
Frequency		2,412		2,484	MHz
Sensitivity 802.11b	1Mbps DSS		-98		dBm
	2Mbps DSS		-94		
	5.5Mbps DSS		-92		
	11Mbps DSS		-88		
Sensitivity 802.11g	6Mbps OFDM		-90		
	9Mbps OFDM		-89		
	12Mbps OFDM		-88		
	18Mbps OFDM		-85		
	24Mbps OFDM		-83		
	36Mbps OFDM		-80		
	48Mbps OFDM		-76		
Sensitivity 802.11n (BW=20MHz)	54Mbps OFDM		-74		
	MCS 0		-89		
	MCS 1		-87		
	MCS 2		-85		
	MCS 3		-82		
	MCS 4		-77		
	MCS 5		-74		
	MCS 6		-72		
Maximum Receive Signal Level	MCS 7		-70.5		
	1-11Mbps DSS		0		
	6-54Mbps OFDM		0		

Parameter	Description	Minimum	Typical	Maximum	Unit
	MCS 0 – 7		0		
Adjacent Channel Rejection	1Mbps DSS (30MHz offset)		50		dB
	11Mbps DSS (25MHz offset)		43		
	6Mbps OFDM (25MHz offset)		40		
	54Mbps OFDM (25MHz offset)		25		
	MCS 0 – 20MHz BW (25MHz offset)		40		
	MCS 7 – 20MHz BW (25MHz offset)		20		
Cellular Blocker Immunity	776-794MHz CDMA		-14		dBm
	824-849MHz GSM		-10		
	880-915MHz GSM		-10		
	1710-1785MHz GSM		-15		
	1850-1910MHz GSM		-15		
	1850-1910MHz WCDMA		-24		
	1920-1980MHz WCDMA		-24		

6.3.2 Transmitter Performance

Radio performance under typical conditions: VBATT=3.3V; VDDIO=3.3V; temp.: 25°C.

Table 6-3. Transmitter Performance

Parameter	Description	Minimum	Typical	Maximum	Unit
Frequency		2,412		2,484	MHz
Output Power ⁽¹⁾ ON_Transmit	802.11b 1Mbps		18.5		dBm
	802.11b 11Mbps		19.5		
	802.11g 6Mbps		18.5		
	802.11g 54Mbps		16.5		
	802.11n MCS 0		17.0		
	802.11n MCS 7		14.5		
TX Power Accuracy			±1.5 ⁽²⁾		dB
Carrier Suppression			30.0		dBc
Harmonic Output Power	2 nd			-41	dBm/MHz
	3 rd			-41	

- Notes: 1. Measured at 802.11 spec compliant EVM/Spectral Mask.
2. Measured after RF matching network. See reference design.

7 External Interfaces

7.1 SPI Interface

7.1.1 Overview

ATWINC1500-MR210PB has a Serial Peripheral Interface (SPI) that operates as a SPI slave. The SPI interface can be used for control and for serial I/O of 802.11 data. The SPI pins are mapped as shown in [Table 7-1](#). The SPI is a full-duplex slave-synchronous serial interface that is available immediately following reset when pin 10 (SPI_CFG) is tied to VDDIO.

Table 7-1. SPI Interface Pin Mapping

Pin #	SPI function
10	CFG: Must be tied to VDDIO
16	SSN: Active Low Slave Select
15	MOSI(RXD): Serial Data Receive
18	SCK: Serial Clock
17	MISO(TXD): Serial Data Transmit

When the SPI is not selected, i.e., when SSN is high, the SPI interface will not interfere with data transfers between the serial-master and other serial-slave devices. When the serial slave is not selected, its transmitted data output is buffered, resulting in a high impedance drive onto the MISO line.

The SPI interface responds to a protocol that allows an external host to read or write any register in the chip as well as initiate DMA transfers.

The SPI SSN, MOSI, MISO, and SCK pins of the ATWINC1500-MR210PB have internal programmable pull-up resistors (See [Section 9.1](#)). These resistors should be programmed to be disabled. Otherwise, if any of the SPI pins are driven to a low level while the ATWINC1500-MR210PB is in the low-power sleep state, the current will flow from the VDDIO supply through the pull-up resistors, increasing the current consumption of the module.

7.1.2 SPI Timing

The SPI timing is provided in [Figure 7-1](#) and [Table 7-2](#).

Figure 7-1. SPI Timing Diagram (SPI Mode CPOL=0, CPHA=0)

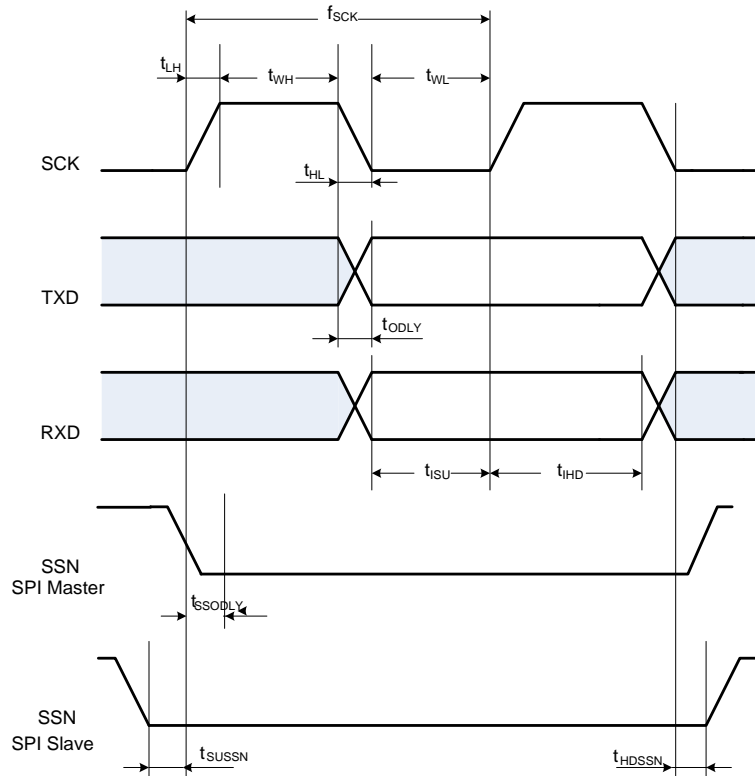

Table 7-2. SPI Slave Timing Parameters

Parameter	Symbol	Min.	Max.	Units	Remarks
Clock Input Frequency	f_{SCK}		48	MHz	
Clock Low Pulse Width	t_{WL}	5		ns	
Clock High Pulse Width	t_{WH}	5			
Clock Rise Time	t_{LH}		5		
Clock Fall Time	t_{HL}		5		
Input Setup Time	t_{ISU}	5			
Input Hold Time	t_{IHD}	5			
Output Delay	t_{ODLY}	0	20		
Slave Select Setup Time	t_{SUSSN}	5			
Slave Select Hold Time	t_{HDSSN}	5			

7.2 UART Interface

The ATWINC1500-MR210PB has a Universal Asynchronous Receiver/Transmitter (UART) interface available on pins 14 and 19. It can be used for control or data transfer if the baud rate is sufficient for a given application. The UART is compatible with the RS-232 standard, where ATWINC1500-MR210PB operates as Data Terminal Equipment (DTE). It has a two-pin RXD/TXD interface.

The UART features programmable baud rate generation with fractional clock division, which allows transmission and reception at a wide variety of standard and non-standard baud rates. The UART input clock is selectable between 10MHz, 5MHz, 2.5MHz, and 1.25MHz. The clock divider value is programmable as 13 integer bits and 3 fractional bits (with 8.0 being the smallest recommended value for normal operation). This results in the maximum supported baud rate of $10\text{MHz}/8.0 = 1.25\text{MBd}$.

The UART can be configured for seven or eight bit operation, with or without parity, with four different parity types (odd, even, mark, or space), and with one or two stop bits. It also has RX and TX FIFOs, which ensure reliable high speed reception and low software overhead transmission. FIFO size is 4 x 8 for both RX and TX direction. The UART also has status registers showing the number of received characters available in the FIFO and various error conditions, as well the ability to generate interrupts based on these status bits.

An example of UART receiving or transmitting a single packet is shown in [Figure 7-2](#). This example shows 7-bit data (0x45), odd parity, and two stop bits.

See the ATWINC1500-MR210PB Programming Guide for information on configuring the UART.

Figure 7-2. Example of UART RX of TX Packet

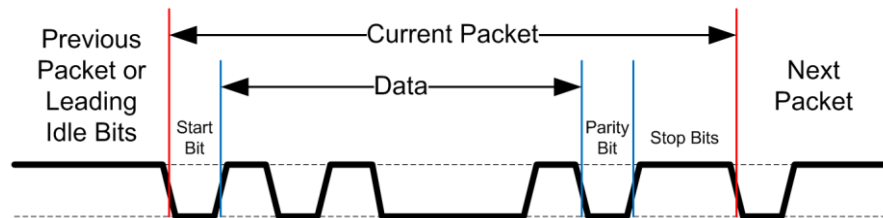

7.3 Wi-Fi/Bluetooth Coexistence

ATWINC1500-MR210PB supports 2- and 3-wire Wi-Fi/Bluetooth Coexistence signaling conforming to the IEEE 802.15.2-2003 standard, Part 15.2. The type of coexistence interface used (2- or 3-wire) is chosen to be compatible with the specific Bluetooth device used in a given application. Coexistence interface can be enabled on the following pins: GPIO_1, GPIO_3, GPIO_4, GPIO_5, GPIO_6, I2C_SCL, I2C_SDA – each of these pins can be configured for any function of the coexistence interface. [Table 7-3](#) shows a usage example of the 2-wire interface using the GPIO_3 and GPIO_4 pins; 3-wire interface using the GPIO_3, GPIO_4, and GPIO_5 pins; for more specific instructions on configuring Coexistence refer to ATWINC1500-MR210PB Programming Guide.

Table 7-3. Coexistence Pin Assignment Example

Pin name	Pin #	Function	Target	2-wire	3-wire
GPIO_3	25	BT_Req	BT is requesting to access the medium to transmit or receive. Goes high on TX or RX slot	Used	Used
GPIO_4	26	WL_Act	Device response to the BT request. High - BT_req is denied and BT slot blocked.	Used	Used
GPIO_5	27	BT_Pri	Priority of the BT packets in the requested slot. High to indicate high priority and low for normal.	Not Used	Used
GPIO_6	1	Ant_SW	Direct control on Antenna (coex bypass)	Optional	Optional

8 Power Consumption

8.1 Description of Device States

ATWINC1500-MR210PB has several Devices States:

- ON_Transmit – Device is actively transmitting an 802.11 signal. Highest output power and nominal current consumption.
- ON_Receive – Device is actively receiving an 802.11 signal. Lowest sensitivity and nominal current consumption.
- ON_Doze – Device is on but is neither transmitting nor receiving
- Power_Down – Device core supply off (Leakage)
- IDLE connect – Device is connected with 1 DTIM beacon interval

The following pins are used to switch between the ON and Power_Down states:

- CHIP_EN – Device pin (pin #22) used to enable DC/DC Converter
- VDDIO – I/O supply voltage from external supply

In the ON states, VDDIO is on and CHIP_EN is high (at VDDIO voltage level). To switch between the ON states and Power_Down state CHIP_EN has to change between high and low (GND) voltage. When VDDIO is off and CHIP_EN is low, the chip is powered off with no leakage (also see Section 8.3).

8.2 Current Consumption in Various Device States

Table 8-1. Current Consumption

Device state	Code rate	Output power, dBm	Current consumption ⁽¹⁾	
			I _{VATT}	I _{VDDIO}
ON_Transmit	802.11b 1Mbps	19.5	294mA	22mA
	802.11b 11Mbps	20.5	290mA	22mA
	802.11g 6Mbps	19.5	292mA	22mA
	802.11g 54Mbps	17.5	250mA	22mA
	802.11n MCS 0	18.0	289mA	22mA
	802.11n MCS 7	15.5	244mA	22mA
ON_Receive	802.11b 1Mbps	N/A	52.5mA	22mA
	802.11b 11Mbps	N/A	52.5mA	22mA
	802.11g 6Mbps	N/A	55.0mA	22mA
	802.11g 54Mbps	N/A	57.5mA	22mA
	802.11n MCS 0	N/A	54.0mA	22mA
	802.11n MCS 7	N/A	58.5mA	22mA
ON_Doze	N/A	N/A	380μA	<10μA
Power_Down	N/A	N/A	<0.5μA	<3.5μA

Notes: 1. Conditions: V_{BATT} @ 3.6V, V_{DDIO}@ 3.3V, temp. 25°C.

8.3 Restrictions for Power States

When no power is supplied to the device, for example, the DC/DC Converter output and VDDIO are both off (at ground potential), a voltage cannot be applied to the device pins because each pin contains an ESD diode from the pin to supply. This diode will turn on when voltage higher than one diode-drop is supplied to the pin.

If a voltage must be applied to the signal pads while the chip is in a low-power state, the VDDIO supply must be on, so the SLEEP or Power_Down state must be used.

Similarly, to prevent the pin-to-ground diode from turning on, do not apply a voltage that is more than one diode-drop below ground to any pin.

8.4 Power-up/down Sequence

The power-up/down sequence for ATWINC1500-MR210PB is shown in Figure 8-1. The timing parameters are provided in Table 8-2.

Figure 8-1. Power Up/Down Sequence

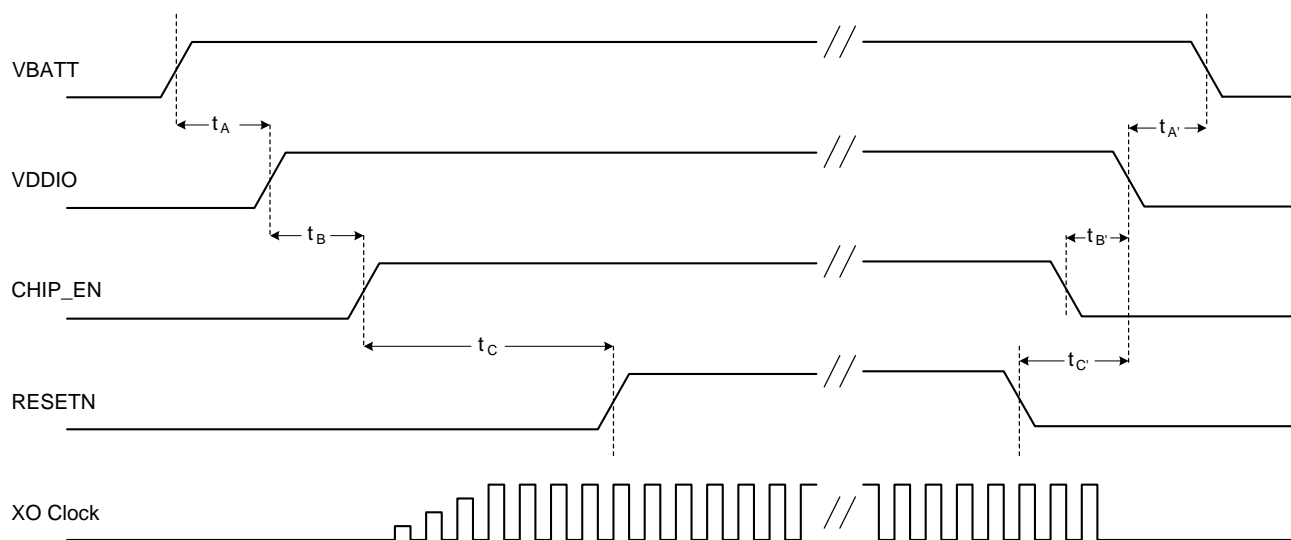

Table 8-2. Power-up/down Sequence Timing

Parameter	Min.	Max.	Units	Description	Notes
t_A	0		ms	VBATT rise to VDDIO rise	VBATT and VDDIO can rise simultaneously or can be tied together. VDDIO must not rise before VBATT.
t_B	0		ms	VDDIO rise to CHIP_EN rise	CHIP_EN must not rise before VDDIO. CHIP_EN must be driven high or low, not left floating.
t_C	5		ms	CHIP_EN rise to RESETN rise	This delay is needed because XO clock must stabilize before RESETN removal. RESETN must be driven high or low, not left floating.
$t_{A'}$	0		ms	VDDIO fall to VBATT fall	VBATT and VDDIO can fall simultaneously or can be tied together. VBATT must not fall before VDDIO.

Parameter	Min.	Max.	Units	Description	Notes
tb'	0		ms	CHIP_EN fall to VDDIO fall	VDDIO must not fall before CHIP_EN. CHIP_EN and RESETN can fall simultaneously.
tc'	0		ms	RESETN fall to VDDIO fall	VDDIO must not fall before RESETN. RESETN and CHIP_EN can fall simultaneously.

8.5 Digital I/O Pin Behavior During Power-up Sequences

Table 8-3 represents digital I/O Pin states corresponding to device power modes.

Table 8-3. Digital I/O Pin Behavior in Different Device States

Device state	VDDIO	CHIP_EN	RESETN	Output driver	Input driver	Pull-up/down resistor (96kΩ)
Power Down: core supply off	High	Low	Low	Disabled (Hi-Z)	Disabled	Disabled
Power-On Reset: core supply on, hard reset on	High	High	Low	Disabled (Hi-Z)	Disabled	Enabled
Power-On Default: core supply on, device out of reset but not programmed yet	High	High	High	Disabled (Hi-Z)	Enabled	Enabled
On Sleep/ On Transmit/ On Receive: core supply on, device programmed by firmware	High	High	High	Programmed by firmware for each pin: Enabled or Disabled	Opposite of Output Driver state	Programmed by firmware for each pin: Enabled or Disabled

9 Notes On Interfacing to the ATWINC1500-MR210PB

9.1 Programmable Pull-up Resistors

The ATWINC1500-MR210PB provides programmable pull-up resistors on various pins. The purpose of these resistors is to keep any unused input pins from floating which can cause excess current to flow through the input buffer from the VDDIO supply. Any unused module pin on the ATWINC1500-MR210PB should leave these pull-up resistors enabled so the pin will not float. The default state at power up is for the pull-up resistor to be enabled. However, any pin which is used, should have the pull-up resistor disabled. The reason for this is that if any pins are driven to a low level while the ATWINC1500-MR210PB is in the low power sleep state, current will flow from the VDDIO supply through the pull-up resistors, increasing the current consumption of the module. Since the value of the pull-up resistor is approximately 100K Ω , the current through any pull-up resistor that is being driven low will be VDDIO/100K. For VDDIO = 3.3V, the current through each pull-up resistor that is driven low would be approximately 3.3V/100K = 33 μ A. Pins which are used and have had the programmable pull-up resistor disabled should always be actively driven to either a high or low level and not be allowed to float.

See the ATWINC1500-MR210PB Programming Guide for information on enabling/disabling the programmable pull up resistors.

10 RF Performance Placement Guidelines

It is critical to follow the recommendations listed below to achieve the best RF performance:

- The module must be placed on the main board – the printed antenna area must overlap with the carrier board. The portion of the module containing the antenna should not go outside the edge of the main board. The antenna is designed to work properly when it is sitting directly on top of a 1.5mm thick printed circuit board.
- If the module is placed at the edge of the main board, a minimum 22mm by 5mm area directly under the antenna must be clear of all metal on all layers of the board. “In-land” placement is acceptable; however deepness of keep-out area must grove to: module edge to main board edge plus 5mm. **DO NOT PLACE THE MODULE IN THE MIDDLE OF THE MAIN BOARD OR FAR AWAY FROM THE MAIN BOARD EDGE.**
- Keep away from the antenna, as far as possible, large metal objects to avoid electromagnetic field blocking
- Do not enclose the antenna within a metal shield
- Keep any components which may radiate noise or signals within the 2.4GHz – 2.5GHz frequency band as far away from the antenna as possible, or better yet, shield those components. Any noise radiated from the main board in this frequency band will degrade the sensitivity of the module.
- Contact Atmel for assistance if any other placement is required

11 Schematic Design Information

This chapter deals with schematic information. Application schematics for SPI and SDIO are provided in figures [Figure 11-1](#) and [Figure 11-2](#). Module design information such as module schematics can be obtained under an NDA from Atmel.

11.1 Application Schematic

Figure 11-1. SPI Application Schematic

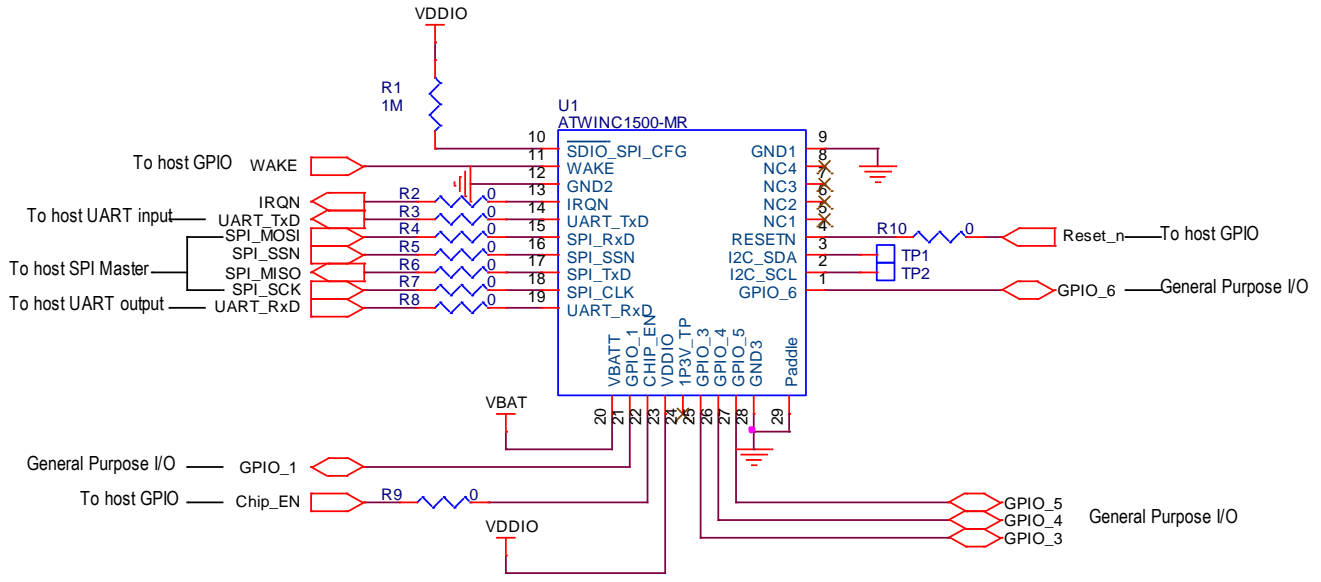

Resistors R2 - R10 are recommended as placeholders in case filtering of noisy signals is required. They also allow disconnecting of module for debug purposes.

Figure 11-2. SDIO Application Schematic

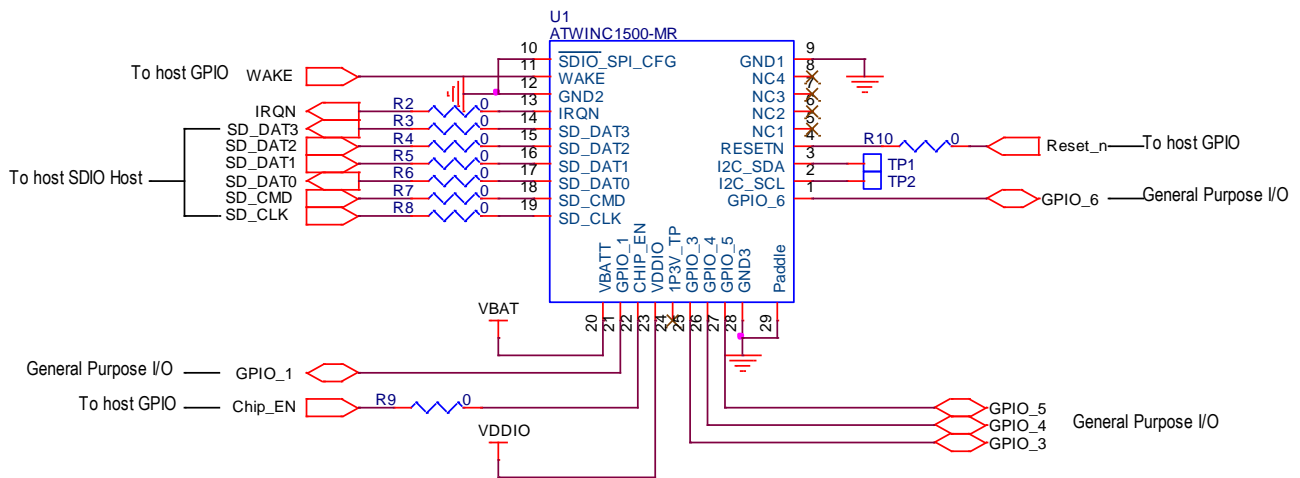

Resistors R2 - R10 are recommended as placeholders in case filtering of noisy signals is required. They also allow disconnecting of module for debug purposes.

12 Reflow Profile Information

This chapter provides guidelines for reflow processes in getting the Atmel module soldered to the customer's design.

12.1 Storage Condition

12.1.1 Moisture Barrier Bag Before Opened

A moisture barrier bag must be stored in a temperature of less than 30°C with humidity under 85% RH.

The calculated shelf life for the dry-packed product shall be 12 months from the date the bag is sealed.

12.1.2 Moisture Barrier Bag Open

Humidity indicator cards must be blue, <30%.

12.2 Stencil Design

The recommended stencil is laser-cut, stainless steel type with thickness of 100µm to 130µm and approximately a 1:1 ratio of stencil opening to pad dimension. To improve paste release, a positive taper with bottom opening 25µm larger than the top can be utilized. Local manufacturing experience may find other combinations of stencil thickness and aperture size to get good results.

12.3 Baking Conditions

This module is rated at MSL level 3. After sealed bag is opened, no baking is required within 168 hours so long as the devices are held at ≤30°C/60% RH or stored at <10% RH.

The module will require baking before mounting if:

- The sealed bag has been open for >168 hours
- Humidity Indicator Card reads >10%
- SIPs need to be baked for 8 hours at 125°C

12.4 Soldering and Reflow Condition

12.4.1 Reflow Oven

It is strongly recommended that a reflow oven equipped with more heating zones and Nitrogen atmosphere should be used for lead-free assembly. Nitrogen atmosphere has shown to improve the wet-ability and reduce temperature gradient across the board. It can also enhance the appearance of the solder joints by reducing the effects of oxidation.

The following bullet items should also be observed in the reflow process:

- Some recommended pastes include NC-SMQ® 230 flux and Indalloy® 241 solder paste made up of 95.5 Sn/3.8 Ag/0.7 Cu or SENJU N705-GRN3360-K2-V Type 3, no clean paste
- Allowable reflow soldering times: Two times based on the following reflow soldering profile (see [Figure 12-1](#))
- Temperature profile: Reflow soldering shall be done according to the following temperature profile (see [Figure 12-1](#))
- Peak temp.: 250°C

Figure 12-1. Solder Reflow Profile

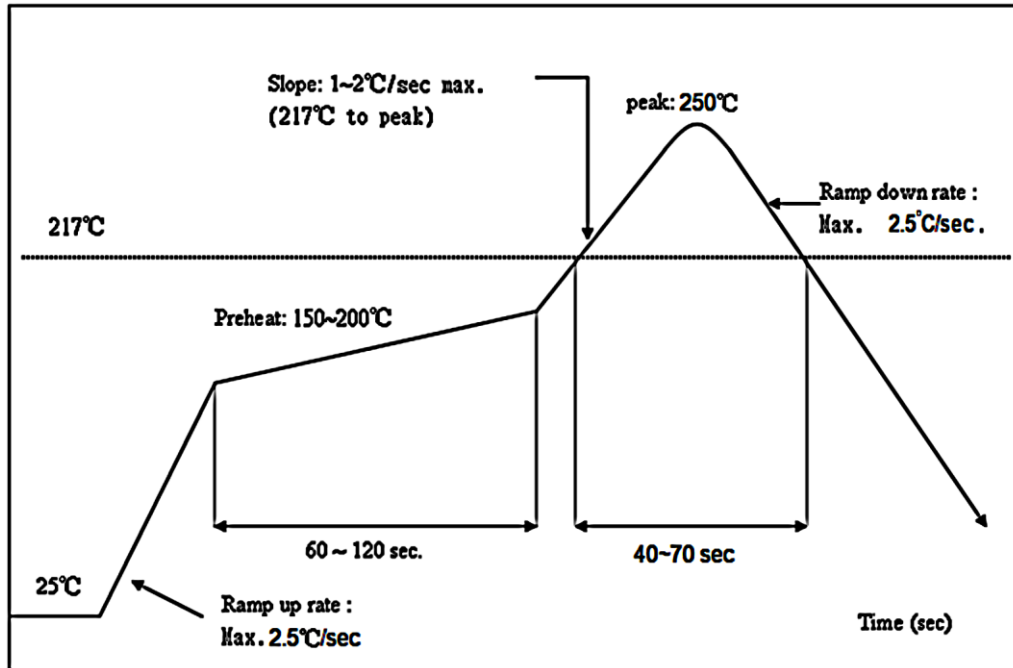

13 Reference Documentation and Support

13.1 Reference Documents

Atmel offers a set of collateral documentation to ease integration and device ramp.

The following table lists documents available on the Atmel web or are integrated in development tools.

Title	Content
ATWINC1500 MU Device Datasheet	Datasheet for the ATWINC1500 SmartConnect Wi-Fi component.
Design Files Package	User Guide, Schematic, PCB layout, Gerber, BOM and System notes on: RF/Radio Full Test Report, radiation pattern, design guidelines, temperature performance, ESD.
Platform Getting Started Guide	How to use package: Out-of-the-Box starting guide, HW limitations and notes, SW Quick start guidelines.
HW Design Guide	Best practices and recommendations to design a board with the product. Including: Antenna Design for Wi-Fi (layout recommendations, types of antennas, impedance matching, using a power amplifier etc.), SPI/UART protocol between Wi-Fi SoC and the Host MCU.
SW Design Guide	Integration guide with clear description of: High level Arch, overview on how to write a networking application, list all API, parameters and structures. Features of the device, SPI/handshake protocol between device and host MCU, with flow/sequence/state diagram, timing.
SW Program- mer Guide	Explain in details the flow chart and how to use each API to implement all generic use cases (e.g. start AP, start STA, provisioning, UDP, TCP, http, TLS, p2p, errors management, connection/transfer recovery mechanism/state diagram) - usage and sample application note

For a complete listing of development-support tools and documentation, visit <http://www.atmel.com/>, or contact the nearest Atmel field representative.

14 Revision History

Doc Rev.	Date	Comments
42502B	02/2016	<ol style="list-style-type: none"> 1. Revised Module outline drawings to show Ground pad to be soldered. 2. Pulled out Footprint drawing as this is covered in the Module drawing. 3. Updated Copyright for 2016. 4. Updated footers. 5. Revised Transmit Performance Table 6-3. 6. Revised current table references in Table 8-1. 7. Added uFL info to RF Section 10. 8. Updated Schematics Section 11 text and figures Figure 11-1 and Figure 11-2. 9. Updated Document Reference table to include the ATWINC1500-MU datasheet. 10. Revised section 12 Reflow Profile Information.
42376A	07/2015	<p>Updated due to changes from ATWINC1500A to ATWINC1500B:</p> <ol style="list-style-type: none"> 1. Updated power numbers and description, added high-power and low-power modes. 2. Updated radio performance numbers. 4. Updated reference schematic and pin list to add GPIOs 3,4,5,6. 5. Fixed typos in SPI interface timing. 6. Added hardware accelerators in feature list (security and checksum). 7. Increased instruction RAM size from 128KB to 160KB. 8. Improved and corrected description of Coexistence interface. 9. Miscellaneous minor updates and corrections.



Atmel Corporation 1600 Technology Drive, San Jose, CA 95110 USA **T:** (+1)(408) 441.0311 **F:** (+1)(408) 436.4200 | **www.atmel.com**

© 2016 Atmel Corporation. / Rev.: Atmel-42502B-ATWINC1500-MR210PB-SmartConnect-Datasheet_02/2016.

Atmel®, Atmel logo and combinations thereof, Enabling Unlimited Possibilities®, and others are registered trademarks or trademarks of Atmel Corporation in U.S. and other countries. Other terms and product names may be trademarks of others.

DISCLAIMER: The information in this document is provided in connection with Atmel products. No license, express or implied, by estoppel or otherwise, to any intellectual property right is granted by this document or in connection with the sale of Atmel products. EXCEPT AS SET FORTH IN THE ATMEL TERMS AND CONDITIONS OF SALES LOCATED ON THE ATMEL WEBSITE, ATMEL ASSUMES NO LIABILITY WHATSOEVER AND DISCLAIMS ANY EXPRESS, IMPLIED OR STATUTORY WARRANTY RELATING TO ITS PRODUCTS INCLUDING, BUT NOT LIMITED TO, THE IMPLIED WARRANTY OF MERCHANTABILITY, FITNESS FOR A PARTICULAR PURPOSE, OR NON-INFRINGEMENT. IN NO EVENT SHALL ATMEL BE LIABLE FOR ANY DIRECT, INDIRECT, CONSEQUENTIAL, PUNITIVE, SPECIAL OR INCIDENTAL DAMAGES (INCLUDING, WITHOUT LIMITATION, DAMAGES FOR LOSS AND PROFITS, BUSINESS INTERRUPTION, OR LOSS OF INFORMATION) ARISING OUT OF THE USE OR INABILITY TO USE THIS DOCUMENT, EVEN IF ATMEL HAS BEEN ADVISED OF THE POSSIBILITY OF SUCH DAMAGES. Atmel makes no representations or warranties with respect to the accuracy or completeness of the contents of this document and reserves the right to make changes to specifications and products descriptions at any time without notice. Atmel does not make any commitment to update the information contained herein. Unless specifically provided otherwise, Atmel products are not suitable for, and shall not be used in, automotive applications. Atmel products are not intended, authorized, or warranted for use as components in applications intended to support or sustain life.

SAFETY-CRITICAL, MILITARY, AND AUTOMOTIVE APPLICATIONS DISCLAIMER: Atmel products are not designed for and will not be used in connection with any applications where the failure of such products would reasonably be expected to result in significant personal injury or death ("Safety-Critical Applications") without an Atmel officer's specific written consent. Safety-Critical Applications include, without limitation, life support devices and systems, equipment or systems for the operation of nuclear facilities and weapons systems. Atmel products are not designed nor intended for use in military or aerospace applications or environments unless specifically designated by Atmel as military-grade. Atmel products are not designed nor intended for use in automotive applications unless specifically designated by Atmel as automotive-grade.

Mouser Electronics

Authorized Distributor

Click to View Pricing, Inventory, Delivery & Lifecycle Information:

[Atmel:](#)

[ATWINC1500-MR210PB](#) [ATWINC1510-MR210UB](#)