



MICROCHIP

**BodyCom™ Development Kit
User's Guide**

Note the following details of the code protection feature on Microchip devices:

- Microchip products meet the specification contained in their particular Microchip Data Sheet.
- Microchip believes that its family of products is one of the most secure families of its kind on the market today, when used in the intended manner and under normal conditions.
- There are dishonest and possibly illegal methods used to breach the code protection feature. All of these methods, to our knowledge, require using the Microchip products in a manner outside the operating specifications contained in Microchip's Data Sheets. Most likely, the person doing so is engaged in theft of intellectual property.
- Microchip is willing to work with the customer who is concerned about the integrity of their code.
- Neither Microchip nor any other semiconductor manufacturer can guarantee the security of their code. Code protection does not mean that we are guaranteeing the product as "unbreakable."

Code protection is constantly evolving. We at Microchip are committed to continuously improving the code protection features of our products. Attempts to break Microchip's code protection feature may be a violation of the Digital Millennium Copyright Act. If such acts allow unauthorized access to your software or other copyrighted work, you may have a right to sue for relief under that Act.

Information contained in this publication regarding device applications and the like is provided only for your convenience and may be superseded by updates. It is your responsibility to ensure that your application meets with your specifications. MICROCHIP MAKES NO REPRESENTATIONS OR WARRANTIES OF ANY KIND WHETHER EXPRESS OR IMPLIED, WRITTEN OR ORAL, STATUTORY OR OTHERWISE, RELATED TO THE INFORMATION, INCLUDING BUT NOT LIMITED TO ITS CONDITION, QUALITY, PERFORMANCE, MERCHANTABILITY OR FITNESS FOR PURPOSE. Microchip disclaims all liability arising from this information and its use. Use of Microchip devices in life support and/or safety applications is entirely at the buyer's risk, and the buyer agrees to defend, indemnify and hold harmless Microchip from any and all damages, claims, suits, or expenses resulting from such use. No licenses are conveyed, implicitly or otherwise, under any Microchip intellectual property rights.

Trademarks

The Microchip name and logo, the Microchip logo, dsPIC, FlashFlex, KEELOQ, KEELOQ logo, MPLAB, PIC, PICmicro, PICSTART, PIC³² logo, rPIC, SST, SST Logo, SuperFlash and UNI/O are registered trademarks of Microchip Technology Incorporated in the U.S.A. and other countries.

FilterLab, Hampshire, HI-TECH C, Linear Active Thermistor, MTP, SEEVAL and The Embedded Control Solutions Company are registered trademarks of Microchip Technology Incorporated in the U.S.A.

Silicon Storage Technology is a registered trademark of Microchip Technology Inc. in other countries.

Analog-for-the-Digital Age, Application Maestro, BodyCom, chipKIT, chipKIT logo, CodeGuard, dsPICDEM, dsPICDEM.net, dsPICworks, dsSPEAK, ECAN, ECONOMONITOR, FanSense, HI-TIDE, In-Circuit Serial Programming, ICSP, Mindi, MiWi, MPASM, MPF, MPLAB Certified logo, MPLIB, MPLINK, mTouch, Omniscient Code Generation, PICC, PICC-18, PICDEM, PICDEM.net, PICkit, PICtail, REAL ICE, rLAB, Select Mode, SQI, Serial Quad I/O, Total Endurance, TSHARC, UniWinDriver, WiperLock, ZENA and Z-Scale are trademarks of Microchip Technology Incorporated in the U.S.A. and other countries.

SQTP is a service mark of Microchip Technology Incorporated in the U.S.A.

GestIC and ULPP are registered trademarks of Microchip Technology Germany II GmbH & Co. & KG, a subsidiary of Microchip Technology Inc., in other countries.

All other trademarks mentioned herein are property of their respective companies.

© 2012, Microchip Technology Incorporated, Printed in the U.S.A., All Rights Reserved.

 Printed on recycled paper.

ISBN: 9781620767085

QUALITY MANAGEMENT SYSTEM
CERTIFIED BY DNV
== ISO/TS 16949 ==

Microchip received ISO/TS-16949:2009 certification for its worldwide headquarters, design and wafer fabrication facilities in Chandler and Tempe, Arizona; Gresham, Oregon and design centers in California and India. The Company's quality system processes and procedures are for its PIC[®] MCUs and dsPIC[®] DSCs, KEELOQ[®] code hopping devices, Serial EEPROMs, microperipherals, nonvolatile memory and analog products. In addition, Microchip's quality system for the design and manufacture of development systems is ISO 9001:2000 certified.

Manufacturer: Microchip Technology Inc.
2355 W. Chandler Blvd.
Chandler, Arizona, 85224-6199
USA

This declaration of conformity is issued by the manufacturer.

The development/evaluation tool is designed to be used for research and development in a laboratory environment. This development/evaluation tool is not intended to be a finished appliance, nor is it intended for incorporation into finished appliances that are made commercially available as single functional units to end users. This development/evaluation tool complies with EU EMC Directive 2004/108/EC and as supported by the European Commission's Guide for the EMC Directive 2004/108/EC (8th February 2010).

This development/evaluation tool complies with EU RoHS2 Directive 2011/65/EU.

For information regarding the exclusive, limited warranties applicable to Microchip products, please see Microchip's standard terms and conditions of sale, which are printed on our sales documentation and available at www.microchip.com.

Signed for and on behalf of Microchip Technology Inc. at Chandler, Arizona, USA



Derek Carlson
VP Development Tools

05-DEC-2011
Date

BodyCom™ Development Kit User's Guide

NOTES:



BodyCom™ DEVELOPMENT KIT USER'S GUIDE

Table of Contents

Preface	7
Introduction	7
Document Layout.....	7
Conventions Used in this Guide	8
Recommended Reading	9
The Microchip Web Site.....	9
Customer Support.....	11
Document Revision History	11
Chapter 1: Introduction	13
Chapter 2: BodyCom Demonstration Application	21
Chapter 3: BodyCom Development Kit Hardware	29
Appendix A. Development Kit Schematics	35

BodyCom™ Development Kit User's Guide

NOTES:

Preface

NOTICE TO CUSTOMERS

All documentation becomes dated, and this manual is no exception. Microchip tools and documentation are constantly evolving to meet customer needs, so some actual dialogs and/or tool descriptions may differ from those in this document. Please refer to our web site (www.microchip.com) to obtain the latest documentation available.

Documents are identified with a “DS” number. This number is located on the bottom of each page, in front of the page number. The numbering convention for the DS number is “DSXXXXA”, where “XXXX” is the document number and “A” is the revision level of the document.

For the most up-to-date information on development tools, see the MPLAB® IDE online help. Select the Help menu, and then Topics to open a list of available online help files.

INTRODUCTION

This chapter contains general information that will be useful to know before using the BodyCom Development Kit. Items discussed in this chapter include:

- Document Layout
- Conventions Used in this Guide
- Warranty Registration
- Recommended Reading
- The Microchip Web Site
- Development Systems Customer Change Notification Service
- Customer Support
- Revision History

DOCUMENT LAYOUT

This document describes how to use the BodyCom Development Kit as a development tool to emulate and debug firmware on a target board. The manual layout is as follows:

- **Chapter 1. “Introduction”** – This chapter introduces the user to the BodyCom Demonstration Kit and provides an overview of its features.
- **Chapter 2. “BodyCom Demonstration Application”** – This chapter describes how to work with the supplied BodyCom Demonstration firmware.
- **Chapter 3. “BodyCom Development Kit Hardware”** – This chapter provides a more detailed description of the BodyCom Development Kit Hardware and configuration settings.
- **Appendix A. “Development Kit Schematics”** – This chapter provides the Development Kit Schematics.

BodyCom™ Development Kit

CONVENTIONS USED IN THIS GUIDE

This manual uses the following documentation conventions:

DOCUMENTATION CONVENTIONS

Description	Represents	Examples
Arial font:		
Italic characters	Referenced books	<i>MPLAB® IDE User's Guide</i>
	Emphasized text	...is the <i>only</i> compiler...
Initial caps	A window	the Output window
	A dialog	the Settings dialog
	A menu selection	select Enable Programmer
Quotes	A field name in a window or dialog	"Save project before build"
Underlined, italic text with right angle bracket	A menu path	<u><i>File>Save</i></u>
Bold characters	A dialog button	Click OK
	A tab	Click the Power tab
N'Rnnnn	A number in verilog format, where N is the total number of digits, R is the radix and n is a digit.	4'b0010, 2'hF1
Text in angle brackets < >	A key on the keyboard	Press <Enter>, <F1>
Courier New font:		
Plain Courier New	Sample source code	#define START
	Filenames	autoexec.bat
	File paths	c:\mcc18\h
	Keywords	_asm, _endasm, static
	Command-line options	-Opa+, -Opa-
	Bit values	0, 1
	Constants	0xFF, 'A'
Italic Courier New	A variable argument	<i>file.o</i> , where <i>file</i> can be any valid filename
Square brackets []	Optional arguments	mcc18 [options] <i>file</i> [options]
Curly brackets and pipe character: { }	Choice of mutually exclusive arguments; an OR selection	errorlevel {0 1}
Ellipses...	Replaces repeated text	var_name [, var_name...]
	Represents code supplied by user	void main (void) { ... }

WARRANTY REGISTRATION

Please complete the enclosed Warranty Registration Card and mail it promptly. Sending in the Warranty Registration Card entitles users to receive new product updates. Interim software releases are available at the Microchip web site.

RECOMMENDED READING

This user's guide describes how to use the BodyCom Development Kit. Other useful documents are listed below. The following Microchip documents are available and recommended as supplemental reference resources.

Release Notes for MPLAB[®] ICD 3 In-Circuit Debugger

For the latest information on using the BodyCom Development Kit, read the "Readme for BodyCom Development Kit.htm" file (an HTML file) in the Readmes subdirectory of the MPLAB IDE installation directory. The release notes (Readme) contains update information and known issues that may not be included in this user's guide.

BodyCom™ Development Kit

THE MICROCHIP WEB SITE

Microchip provides online support via our web site at www.microchip.com. This web site is used as a means to make files and information easily available to customers. Accessible by using your favorite Internet browser, the web site contains the following information:

- **Product Support** – Data sheets and errata, application notes and sample programs, design resources, user's guides and hardware support documents, latest software releases and archived software
- **General Technical Support** – Frequently Asked Questions (FAQs), technical support requests, online discussion groups, Microchip consultant program member listing
- **Business of Microchip** – Product selector and ordering guides, latest Microchip press releases, listing of seminars and events, listings of Microchip sales offices, distributors and factory representatives

DEVELOPMENT SYSTEMS CUSTOMER CHANGE NOTIFICATION SERVICE

Microchip's customer notification service helps keep customers current on Microchip products. Subscribers will receive e-mail notification whenever there are changes, updates, revisions or errata related to a specified product family or development tool of interest.

To register, access the Microchip web site at www.microchip.com, click on Customer Change Notification and follow the registration instructions.

The Development Systems product group categories are:

- **Compilers** – The latest information on Microchip C compilers, assemblers, linkers and other language tools. These include all MPLAB C compilers; all MPLAB assemblers (including MPASM™ assembler); all MPLAB linkers (including MPLINK™ object linker); and all MPLAB librarians (including MPLIB™ object librarian).
- **Emulators** – The latest information on Microchip in-circuit emulators. This includes the MPLAB® REAL ICE™ and MPLAB ICE 2000 in-circuit emulators.
- **In-Circuit Debuggers** – The latest information on the Microchip in-circuit debuggers. This includes MPLAB ICD 3 in-circuit debuggers and PICKit™ 3 debug express.
- **MPLAB® IDE** – The latest information on Microchip MPLAB IDE, the Windows® Integrated Development Environment for development systems tools. This list is focused on the MPLAB IDE, MPLAB IDE Project Manager, MPLAB Editor and MPLAB SIM simulator, as well as general editing and debugging features.
- **Programmers** – The latest information on Microchip programmers. These include production programmers such as MPLAB REAL ICE in-circuit emulator, MPLAB ICD 3 in-circuit debugger and MPLAB PM3 device programmers. Also included are nonproduction development programmers such as PICSTART® Plus and PICKit 2 and 3.

CUSTOMER SUPPORT

Users of Microchip products can receive assistance through several channels:

- Distributor or Representative
- Local Sales Office
- Field Application Engineer (FAE)
- Technical Support

Customers should contact their distributor, representative or field application engineer (FAE) for support. Local sales offices are also available to help customers. A listing of sales offices and locations is included in the back of this document.

Technical support is available through the web site at:

<http://www.microchip.com/support>.

REVISION HISTORY

Revision A (August 2012)

Initial release of this document.

Revision B (November 2012)

Revised Sections 2.1.1, 2.3, 2.4.2.4.

BodyCom™ Development Kit

NOTES:

Chapter 1. Introduction

1.1 INTRODUCTION

Thank you for purchasing Microchip Technology's BodyCom Development Kit. This board provides a low-cost and simple solution for integrating the BodyCom system into a wide range of applications. The demonstration software programmed into the supplied PIC16LF1829 20-pin Flash MCU with XLP technology displays information using the on-board LCD and contains firmware to demonstrate the methods of working with the BodyCom source code framework. The application demonstrates basic communication between a base station and single or multiple Mobile units using the BodyCom communication method. Contained in the firmware are options useful for debugging or evaluating a BodyCom application design, as well as a menu system, which allows the user to view mobile devices actively paired to the base station. These applications have been optimized for quick, efficient and simple adaptation; thus have been designed in a portable code method to reduce implementation time of the BodyCom framework.

The BodyCom Development Kit also includes (2) Mobile units, which are enclosed within a generic key fob. These Mobile units have been pre-programmed with firmware, which allows them to communicate with the base station; each unit possessing its own unique ID number paired with the Base unit. The Mobile units, once powered, will enter a Sleep state until a request is received from the Base unit. After receiving a request, the Mobile units will wake up, generate a response and then return to Sleep until any other information is requested. The mobile circuit and firmware can easily be adapted for quick and easy custom Mobile unit designs.

Please visit the following web site to download the latest quick start guide, user's guide, application firmware, bootloader source code and BodyCom GUI executable:

<http://www.microchip.com/Security>

BodyCom™ Development Kit User's Guide

1.2 HIGHLIGHTS

The BodyCom Development Kit includes these features:

Base Unit

- PIC16LF1829 20-pin Flash MCU with XLP technology
- 16x2 character LCD w/backlight and controller
- Multiple oscillator options:
 - 8.192 MHz canned oscillator
 - 8.192 MHz crystal oscillator
- Multiple power source options:
 - USB Mini-B to USB-B 5V cable (included)
 - 9V external power supply (not included)
- Two coupling pad boards designs (vertical and diagonal)
- Full-bridge MOSFET LC driver circuit example design
- Touch/Signal prototyping pins
- Configuration selection jumpers to disable board components
- Four push buttons
- One Power LED
- One Application LED
- On-chip program Flash memory and EEPROM storage
- MCP2200 with Bootloader support for easy firmware upgrades
- Generous prototyping area with (+9V, +5V, +3V and GND rails)
- Support for all Microchip compatible programmers and emulators
- MCP2035 is a single-channel stand-alone Analog Front-End (AFE) device for low-frequency (LF) signal detection

Mobile Unit

- PIC16LF1827 18-pin Flash MCU with XLP technology
- Low-power hex inverter full-bridge LC driver circuit example design
- Example key fob design
- Plastic case
- Two Application LEDs
- On-chip program Flash memory and EEPROM storage
- ICSP™ programming pads
- MCP2035 is a single-channel stand-alone Analog Front-End (AFE) device for low-frequency (LF) signal detection

1.3 WHAT'S IN THE KIT

The BodyCom Development Kit includes the following:

- BodyCom Development Board (Base unit)
- (2) Mobile units with unique identification values (pre-programmed to Base unit)
- (2) Plastic key fob containers
- USB mini-B cable
- BodyCom Development Kit Quick Start Guide

1.4 DEVELOPMENT BOARD FEATURES

1.4.1 Base Unit Hardware

A picture of the BodyCom Development Board is shown in Figure 1-1. The board includes the below components, as indicated in the diagram:

- A. Expansion header
- B. LCD w/backlight
- C. 8.192 MHz crystal
- D. 8.192 MHz canned oscillator
- E. PIC16LF1829 20-pin Flash MCU with XLP technology
- F. SA612AD signal mixer
- G. MCP602 CMOS op amp
- H. Three application push buttons
- I. MCP2035 Analog Front-End (AFE) device
- J. 12 MHz crystal
- K. MCP2200
- L. Mini-B USB connect
- M. Software MCLR button
- N. ICSP programmer header
- O. (2) MCP 1703 LDO
- P. 9V power supply connector
- Q. Generous prototyping area

A more detailed discussion of each feature and its configuration is provided in **Chapter 3. “BodyCom Development Kit Hardware”**.

FIGURE 1-1: BodyCom BOARD LAYOUT

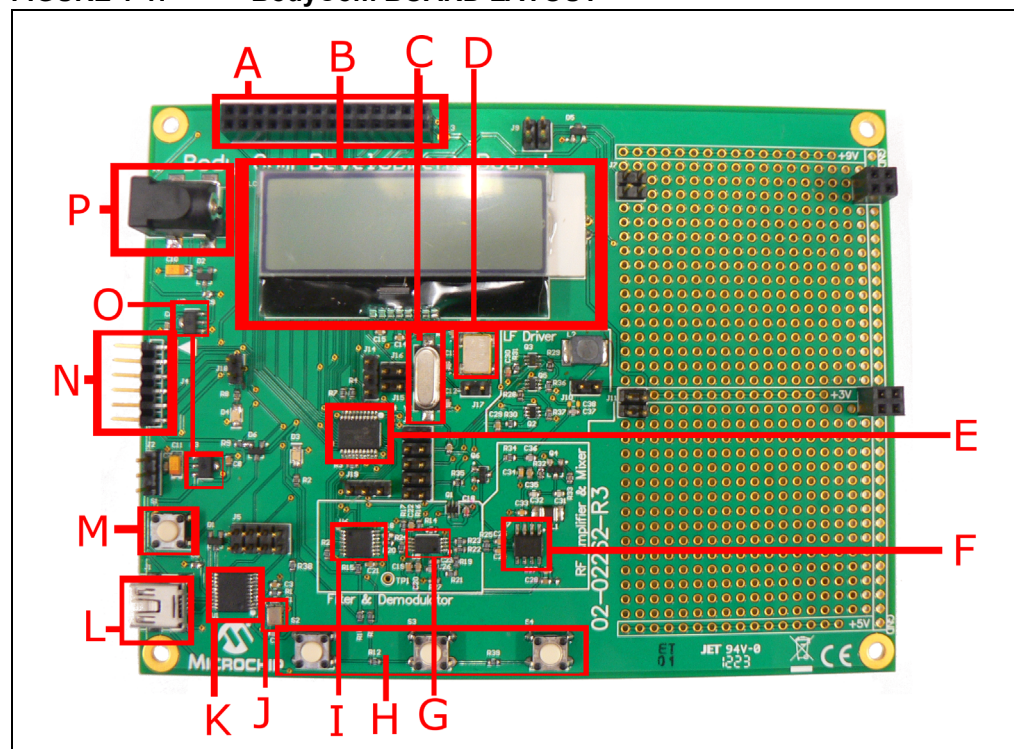

BodyCom™ Development Kit User's Guide

1.4.2 Base Unit Jumpers

The BodyCom Development Board has a versatile range of jumper configurations for future application expansions and prototyping. Figure 1-2 shows the required default jumper configuration for use of the BodyCom Development Board application firmware.

Figure 1-3 has an image of the BodyCom Development Board highlighting the jumper layout as indicated in the diagram:

1. Mixer Clock Select (J14)
2. Crystal oscillator enable (J15 – OSCI, J16 – OSCO)
3. Prototype Touch (Top) and Signal (Bottom) expansion pins (J9)
4. Touch sensor pad connector (J7), Signal coupler connector (J11)
5. Coupling pad enable (J10); connect LC signal to pad
6. Canned oscillator [D] enable; connects canned to OSCI (J17)
7. Base Board Demo Functionality Jumpers:
 - [1-2]: RC2, Touch Sensor (coupling pad)
 - [3-4]: RC3, MOD_OUT (used by LC driver circuit)
 - [5-6]: RA2, MOD_OUT_N (used by LC driver circuit)
 - [7-8]: RA1, SW_DET (push button enable)
 - [9-10]: RC7, ENABLE_RX (enable receive circuit)
8. Input Select:
 - [1-2]: Input on RA4; push button enabled
 - [2-3]: Input on RA3; pin selects OSCO
9. Bootloader MCP2200 Functionality:
 - [1-2]: RC5, USART_TX
 - [3-4]: RC6, USART_RX
 - [5-6]: RA3 (software MCLR), USART_RTS
 - [7-8]: RC7, USART_CTS
10. Power Supply Select:
 - [1-2]: +9V external power supply
 - [3-4]: +5V USB
11. Touch indicator LED enable

FIGURE 1-2: BodyCom BOARD JUMPER CONFIGURATION

Jumper	Status	Function	Jumper	Status	Function			
J2	ON [2:3]	Power Supply [1-2]: 9V [2-3]: USB	J9	OFF	Alternative Touch Sensor [Top pins]: Touch Expansion [Bottom Pins]: Signal Out Expansion			
J5	ON/OFF	Bootloader [1-2]: RC5 - USART_TX [3-4]: RC6 - USART_RX [5-6]: MCLR - USART_RTS [7-8]: RC7 - USART_CTS	J10	ON	Signal Pad Enable Jumper			
			J11	ATTACH	Signal Pad Connector			
			J12	ATTACH	Pad Stability Connector			
			J13	ATTACH	Pad Stability Connector			
J7	ATTACH	Touch Pad Connector	J14	ON [2:3]	Mixer Clock Select [1-2]: OSCO Select [2-3]: OSCI Select			
J8	ON [ALL]	Demo Board Functionality [1-2]: RC2 - Touch [3-4]: RC3 - MOD_OUT [5-6]: RA2 - MOD_OUT_N [7-8]: RA1 - SW_DET [9-10]: RC7 - ENABLE_RX	J15	OFF	OSCI to 8.192 MHz Crystal [C]			
			J16	OFF	OSCO to 8.192 MHz Crystal [C]			
			J17	ON	OSCI from 8.192 MHz Canned OSC [D]			
			J18	ON	Touch LED Indicator Enable			
			J19	ON [2:3]	Push Button Signal [1-2]: Button Detect on RA4 [2-3]: Button Detect on RA3			

FIGURE 1-3: BodyCom BOARD JUMPER LAYOUT

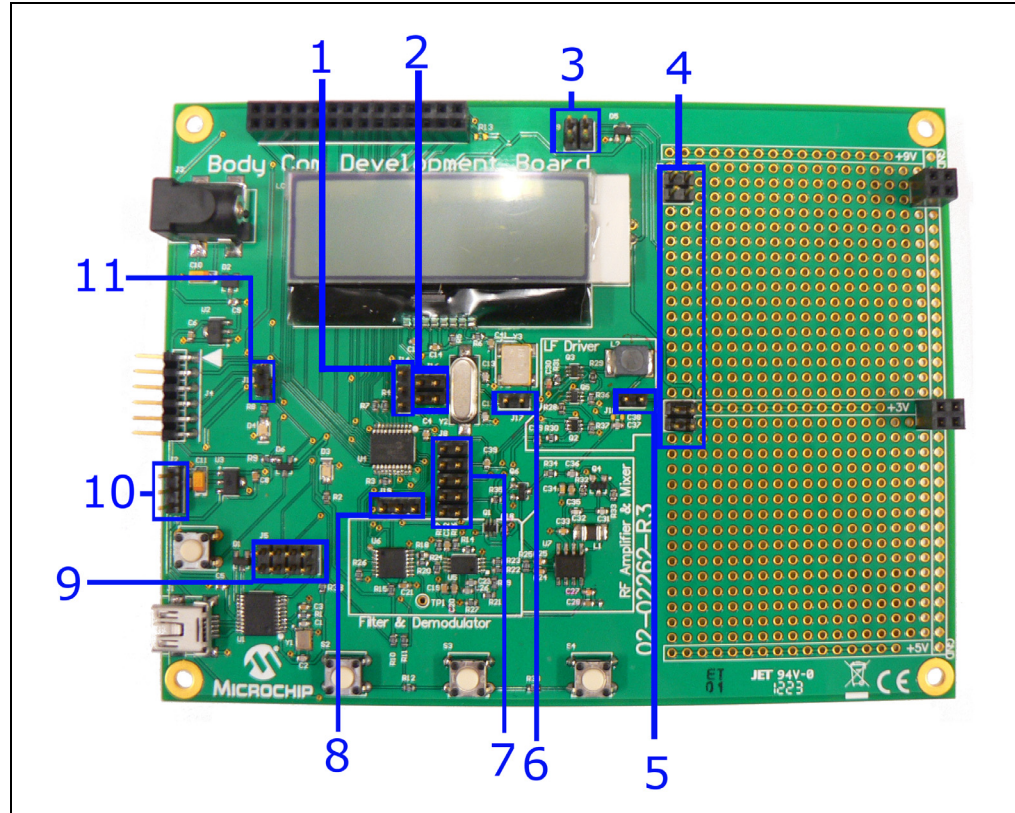

BodyCom™ Development Kit User's Guide

1.4.3 Mobile Unit Hardware

A picture of the BodyCom Development Board is shown in Figure 1-4. The board includes the below components, as indicated in the diagram.

1. +3V 2032 battery clip
2. (2) LED Indicators
3. ICSP programming pads
4. Hex inverter
5. MCP2035 Analog Front-End (AFE) device
6. PIC16LF1827 18-pin Flash MCU with XLP technology
7. Mobile module (a) and coupling pad (b)
8. Key fob casing

FIGURE 1-4: BodyCom MOBILE UNIT HARDWARE

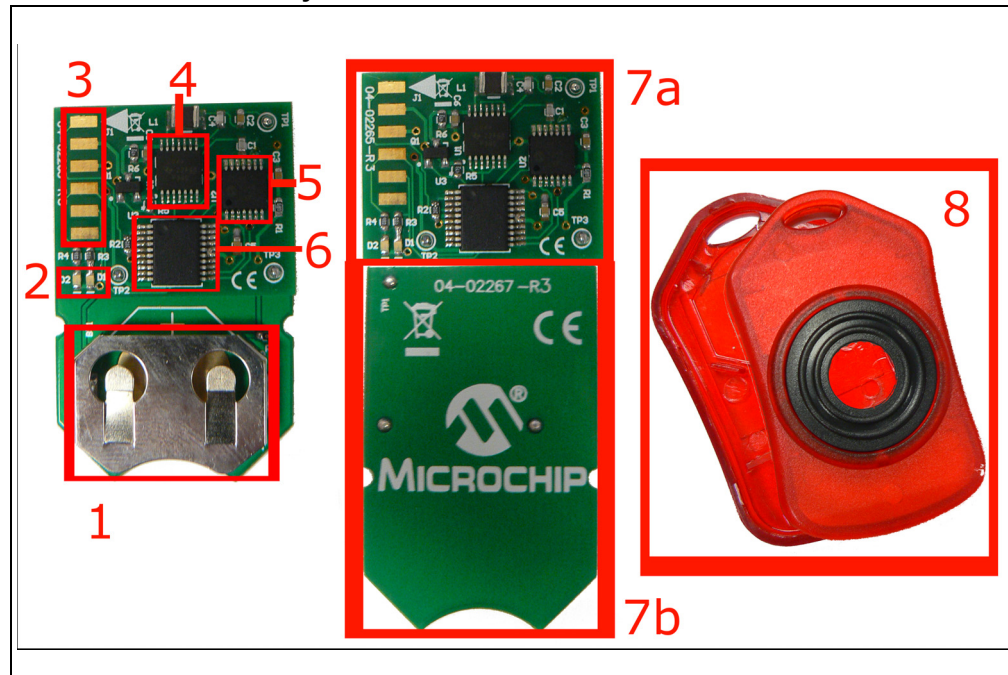

1.5 USING THE DEVELOPMENT KIT OUT OF THE BOX

Although intended as a development platform, the BodyCom Development Kit may also be used directly from the box as a demonstration platform for the pre-programmed PIC16LF1829 microcontroller. The (2) PIC16LF1827 devices on the Mobile units are also pre-programmed to work with the demonstration platform. In addition, the BodyCom Mobile Unit has been designed for easy prototyping.

Refer to **Chapter 2. “BodyCom Demonstration Application”** for details on the demonstration code operation.

Refer to **Chapter 3. “BodyCom Development Kit Hardware”** for details on prototyping and expansion using the Mobile unit design.

1.6 DEMONSTRATION PROGRAM

The pre-programmed example code on the PIC16LF1829 (base) and PIC16LF1827 (mobile) devices is available for download from the Microchip web site (<http://www.microchip.com/Security>). All required project files are provided, so that the code may be used as an example or a platform for further development. These may be

used with the included PIC16LF1829 (base) and PIC16LF1827 (mobile) device by programming the device using a PICkit™ starter kit or any other Microchip programming tool.

1.7 REFERENCE DOCUMENTS

In addition to the documents listed in the “Recommended Reading” section, these documents are also available from Microchip to support the use of the BodyCom Development Kit:

- “PIC16(L)F1826/1827 Data sheet” (DS41391)
- “PIC16(L)F1825/1829 Data sheet” (DS41440)
- “MCP2035 Data sheet” (DS22304)
- “AN1391 Introduction to the BodyCom Technology” (DS01391)
- “AN1310 High-Speed Serial Bootloader for PIC16 and PIC18 Devices (DS01310)
- “PICkit™ 2 Programmer/Debugger User’s Guide” (DS51553)
- “PICkit™ 3 Programmer/Debugger User’s Guide” (DS51795)
- “Compiled Tips ‘n Tricks Guide” (DS01146)

BodyCom™ Development Kit User's Guide

NOTES:

Chapter 2. BodyCom Demonstration Application

This chapter describes the demonstration application that is pre-programmed on the PIC16LF1829 (Base) and PIC16LF1827 (Mobile) microcontrollers, which demonstrates the BodyCom technology in a working application. In the process, the application highlights various features of these two microcontroller families while utilizing peripherals to help reduce the complexity of the system.

2.1 INITIAL SETUP

Although intended as a development platform, BodyCom Development Board is also designed to be used directly from the box as a demonstration platform. The demonstration firmware pre-programmed into both the PIC16LF1829 and PIC16LF1827 microcontroller is ready for immediate use.

The demonstration firmware on the Base unit uses the on-board LCD to display Mobile ID information, mode of operation, navigate debug menu system or view valid paired Mobile IDs. The demonstration firmware on the Mobile unit runs through a short setup state then quickly enters Sleep waking only to respond to base station request, thus entering the maximum power-saving mode.

2.1.1 Configuring and Connecting the Hardware

To get started with the board, verify that it is properly configured:

1. Verify that a power source is selected. Populate power supply select (J2; Pins [2:3], Mid-Bottom pins:
 - a. Pins [1:2] – External +9V power supply. (Not included)
 - b. Pins [2:3] – +5V USB cable. (supplied in kit)
2. Populate (J11) to enable the touch LED indicator.
3. Select an external oscillator source by populating (J14; Pins [2:3], Mid-Bottom pins).
 - a. Pins [1:2] – Crystal oscillator is selected for use. *
 - b. Pins [2:3] – Canned oscillator is selected for use.
4. Populate the canned oscillator enable (J17).
5. Leave Crystal Oscillator Enable (J15, J16) unpopulated. *
6. Populate Coupling Pad Enable (J10).
7. Populate all base board demo functionality (J8).
8. Populate Push Button Enable (J19; Pins [1:2], Left-Mid pins)
 - a. Pins [1:2] – Enable OSCO*
 - b. Pins [2:3] – Enable push buttons
9. Populate Bootloader MCP2200 Functionality (J5).
 - a. DO NOT reprogram via ICSP while (J5) is populated.

BodyCom™ Development Kit User's Guide

- b. For GUI functionality (J5) must be populated; Demo application will work regardless of (J5) configuration.

Note: Selecting crystal oscillator requires multiple jumper alterations.

Default jumper configuration table is shown in Figure 2-1.

FIGURE 2-1: JUMPER TABLE

Jumper	Status	Function	Jumper	Status	Function
J2	ON [2:3]	Power Supply [1-2]: 9V [2-3]: USB	J9	OFF	Alternative Touch Sensor [Top pins]: Touch Expansion [Bottom Pins]: Signal Out Expansion
J5	ON/OFF	Bootloader [1-2]: RC5 - USART_TX [3-4]: RC6 - USART_RX [5-6]: MCLR - USART_RTS [7-8]: RC7 - USART_CTS	J10	ON	Signal Pad Enable Jumper
J7	ATTACH	Touch Pad Connector	J11	ATTACH	Signal Pad Connector
J8	ON [ALL]	Demo Board Functionality [1-2]: RC2 - Touch [3-4]: RC3 - MOD_OUT [5-6]: RA2 - MOD_OUT_N [7-8]: RA1 - SW_DET [9-10]: RC7 - ENABLE_RX	J12	ATTACH	Pad Stability Connector
			J13	ATTACH	Pad Stability Connector
			J14	ON [2:3]	Mixer Clock Select [1-2]: OSCO Select [2-3]: OSCI Select
			J15	OFF	OSCI to 8.192 MHz Crystal [C]
			J16	OFF	OSCO to 8.192 MHz Crystal [C]
			J17	ON	OSCI from 8.192 MHz Canned OSC [D]
			J18	ON	Touch LED Indicator Enable
			J19	ON [2:3]	Push Button Signal [1-2]: Button Detect on RA4 [2-3]: Button Detect on RA3

2.2 DEMONSTRATION PROGRAM OPERATION

The demonstration program uses the on-board LCD for basic menu system navigation and to display all relevant information. The demonstration firmware has been developed to present a real world application using the BodyCom protocol source code to make adaptation of the BodyCom system into existing applications quick and easy; making it easy to move from concept to prototype or to show proof of concept. The application program allows the user to demonstrate the BodyCom system in two operation modes, supplies multiple helpful system debug states within an easy menu structure and a list of valid paired Mobile IDs. The BodyCom Development Board permits the user to experiment with an existing working reference circuit along with functional firmware or can easily be adapted into new circuit designs using the prototyping space provided on the board. The application firmware flowchart is show below in Figure 2-2.

BodyCom Demonstration Application

FIGURE 2-2: BodyCom DEMONSTRATION FIRMWARE FLOWCHART

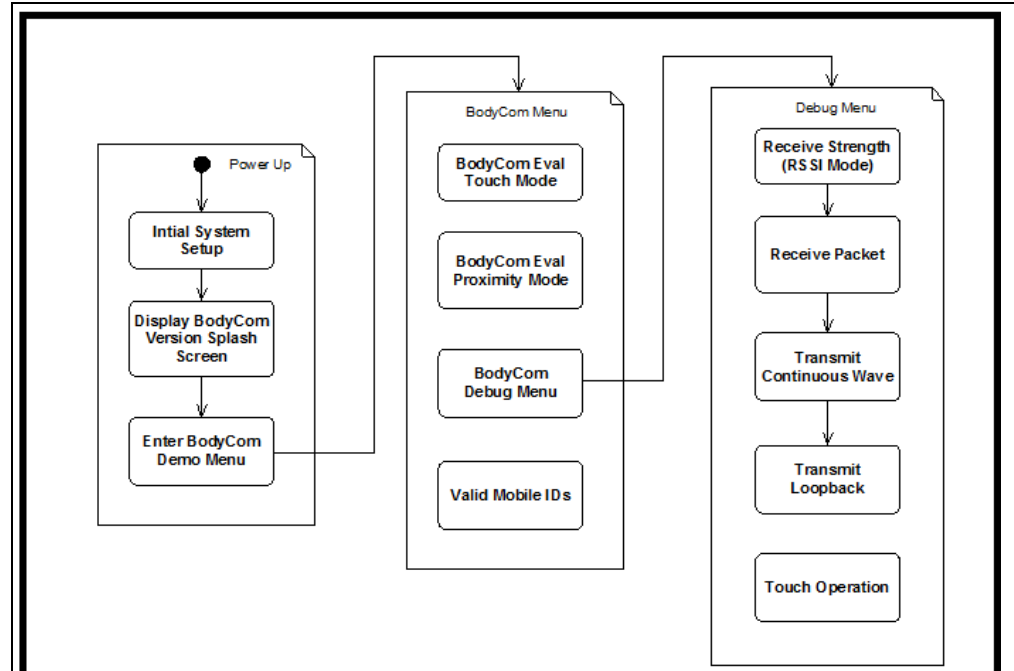

2.3 DEMONSTRATION PROGRAM INITIALIZATION PROCESS

On power-up, the PIC[®] device will first run through its initialization process. The demo specific modifications include disabling the MCLR fuse setting by configuring it as an input. The MCLR functionality will be done via firmware by enabling the Interrupt-On-Change (IOC) feature on the RA3 pin; inside the Interrupt Service Routine (ISR) a software Reset is used. The FOSC bits are configured to External Clock, High-power mode (ECH) and run from the on-board 8.192 kHz canned oscillator. No other Configuration Words (fuse) settings are required by the demonstration program.

The following descriptions highlight initialization for demo specific functions. These are not required for use with the BodyCom Technology system:

- **Timer0** – This module is configured to generate an interrupt-on-overflow and a small TICK counter system is created using the ISR used for state refresh rates. This allows different states to update the LCD display at a rate which is applicable to them. The LCD display is controlled by the software created TICK flag, while the flags set rate (refresh speed) is controlled by the variable TickTmr.
- **BTN_Init()** – This function configures the push buttons **S2 (UP)**, **S3 (DOWN)**, **S4 (SELECT)** for basic operation with the BodyCom demonstration firmware.
- **BTN_Update()** – Once configured, the buttons can be managed by calling the function `BTN_Update()`. Within this function, the current states of each button will be stored and a de-bouncing process will be handled automatically.
- **BTN_Get()** – After `BTN_Update()` has been called, the function `BTN_Get()` will return any press states for use with navigation. This code is very portable, allowing it to be easily adapted to any type of application and has also been written in a very expandable method.
- **RESET()** – Because the S1 is to be used as a software controlled $\overline{\text{MCLR}}$, the on-chip weak pull-up is enabled along with the IOC feature on the RA3 pin. This allows the PIC device to jump to the ISR whenever this button is pressed, regardless of the demo applications current state. From the ISR, the PIC device will be given the `RESET()` command, allowing a software $\overline{\text{MCLR}}$. The on-board debug/application LED connected to RA0 is then configured as an output and

BodyCom™ Development Kit User's Guide

ready for use.

- **lcd_init()** – The LCD display is then configured for use by calling the function `lcd_init()`, which contains the function `i2c_init()` and configure the PIC device for I²C™ communication with the LCD's Chip-On-Glass (COG) controller.
- **lcd_st7032.c and lcd.h** – The source file `Icd_st7032.c` and header file `lcd.h` contain multiple functions useful for working with the LCD display. However, it is important to note that the BodyCom demonstration software uses custom functions to load a LCD buffer, which can be refreshed to update the LCD.

The following descriptions highlight initialization for BodyCom specific functions. These are required for use with BodyCom Technology system:

- **TD_Init()** – This function configures the pin RC2 for use with the CVD mTouch™ method of scanning.
- **TD_CvdHandle()** – The touch detection feature is easily implemented by calling the function whenever a touch scan is required. This makes the use of the CVD mTouch scanning easy to use, very versatile, making it easy to integrate into any future application.
- **BC_HardwareInitSystem()** – This function is called to fully initialize the PIC device being used for BodyCom Technology applications. This function is stored within the source file `bc_hardware_timer2.c`, which is accompanied by the header file `bc_hardware_timer2.h`.
- **bc_hardware_timer2.h** – The `bc_hardware_timer2.h` file contains a large number of defines allowing for a wider range of customizable configurations, for example, the ability to select the BodyCom Technology to use TMR1, TMR2 (demo), TMR4 or TMR6, depending on the available peripherals in an application; source files for these variations can be found in the BodyCom Application folder.
- **BC_TimerON()** – After the BodyCom Technology system is configured, the macro `BC_TimerON()` is called for use with the system. This macro is modified based on the TMR defined within `bc_config.h`.
- **board_GuiEnable** – To enable use of the BodyCom Application GUI with the BodyCom Development Kit, the function `PC_comInit()` is called to configure the system for communication with a PC via USB 2.0 to UART Serial communication using the MCP2200.
- **CheckPairedList()** – The final step before finishing the initialization process is to call the function `BC_ProtocolCheckPairedList()`, which will read from the on-chip EEPROM to decide which Mobile IDs have been paired to the Base unit and will be considered valid during communication. Mobile IDs can be added, viewed or deleted from within the BodyCom Application GUI.

After completing the initialization process, the LCD will display the BodyCom Development Kit welcome splash screen, indicating the current firmware version in use. After a short time, the display will change and the user can begin menu navigation or BodyCom demonstrations.

2.4 BodyCom MENU SYSTEM

From the main menu location, the user has four selections: BodyCom Eval Touch, BodyCom Eval Proximity, Debug Menu and View Mobile ID. This simple menu system can be navigated using the push buttons; **S2 (UP)**, **S3 (DOWN)** and **S4 (SELECT)**. The menu does have a rollover feature implemented, meaning that if the user presses **DOWN** while in the “View Mobile ID” menu state, the navigation will move to “BodyCom Eval Touch”; vice versa pressing UP, while in “BodyCom Eval Touch” will rollover to “View Mobile ID”. The **SELECT** button is multi-purposed based on the current state. **SELECT** has no actions, while in “BodyCom Eval Touch”. However, when in “BodyCom Eval Proximity”, the **SELECT** button will Start/Stop the TX/RX function of the coupling

BodyCom Demonstration Application

pad. Pressing the **SELECT** button while in either the “Debug Menu” or “View Mobile ID” state will Enter/Exit those options, allowing the user to view the debug menu states or paired Mobile IDs by pressing **SELECT** and then exit back to the main menu by again pressing **SELECT**.

2.4.1 BodyCom Touch Mode

The BodyCom Evaluation Touch mode allows the user to demonstrate the BodyCom Technology communication system through use of a dual-purpose coupling pad. Figure 2-3 describes the dual-purpose coupling pad; the vertical and diagonal coupling pads are the same as described. The LCD screen should display “BodyCom Eval _” on the top line, the bottom line should read “Wait for Touch” when the system is ready. The symbol in the top right corner of the first line is used as a CVD state indicator. Refer to Figure 2-4 for a description.

Touching the coupling pad, the indicator green LED (D4) will turn on and the bottom line of the LCD will change to “Searching.....” as the Base unit issues out a command indicating it is searching for a valid Mobile ID. If the user has a valid Mobile unit in possession, the LCD will display the Mobile’s ID on the bottom line of the LCD. Also, the indicator LED will begin to blink indicating valid communications. The Mobile unit will also have a red LED (D1) begin to blink as the Mobile unit transmits. As long as the user stays in possession or within a range of the Mobile unit, the Base and Mobile will continue to communicate each instance indicated by the blinking LEDs. If the user breaks contact with the Base unit or is out of range of the Mobile, the firmware will return to “Wait for Touch” state.

If the user continues to stay in contact with the coupling pad and no valid Mobile ID is found, the display will continue to show “Searching.....” until the CVD indicator changes to “#” upon time out. If the system has a time out, the CVD will re-initialize and wait for another touch. This will require the user to remove the touch and then return it before another scan can occur.

FIGURE 2-3: COUPLING PAD

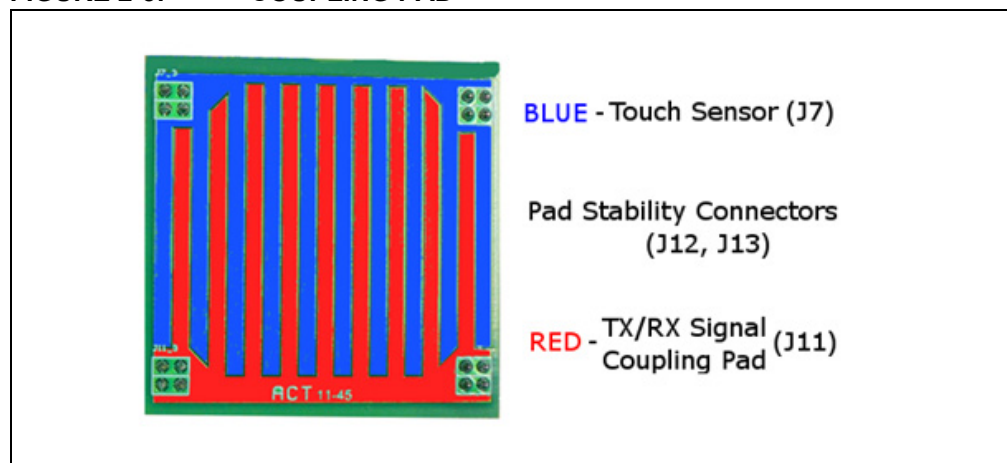

FIGURE 2-4: CVD TOUCH INDICATORS

CVD State	Indicator
Released	—
Pressed	^
Initializing	#
Default	

2.4.1.1 BodyCom PROXIMITY MODE

The BodyCom Evaluation Proximity mode allows the user to demonstrate the BodyCom Technology communication system through use of a single coupling pad. This mode of communication allows the user to trigger the BodyCom Technology scanning process through non-touch based methods. Because this method does not use the CVD mTouch method, no indicators are used.

The LCDs first line will display “BodyCom - Prox” while the second line will show “S4 to Start/Stop”. By pressing the **S4 (SELECT)** button, the user put the Base unit into Scan mode; by pressing it again, it will stop.

By pressing **SELECT (S4)**, the LCDs bottom line will display “Searching.....”. If a valid Mobile ID comes within range of the coupling pad, the bottom line will display the valid ID. If the Mobile ID is moved away from the coupling pad, the display will return to “Searching.....” until the user presses the **SELECT (S4)** button once more. Menu navigation can only occur when the Base unit is NOT SCANNING.

Note: This mode of communication is considered an “Intentional Radiator”.

2.4.2 BodyCom Debug Menu

The BodyCom Evaluation Debug menu is made to help in the development or debugging of applications, which are adapting the BodyCom Technology into their system. These debugging methods are built into the BodyCom framework code and should be used as an example on how to implement them into a user's application.

From the main menu, the user will see the LCD display “Debug Menu” on the top line and “S4 to Enter/Exit” on the bottom line. By pressing the **SELECT (S4)** button, the user enters the Debug menu. Once inside the debug menu, pressing the **SELECT (S4)** button in any state will exit the user back to the “Debug Menu” state of the main menu.

2.4.2.1 RECEIVE STRENGTH

The Receive Strength debug menu state is used to see a functional value for the Receive Signal Strength Indicator (RSSI) pin on the MCP2035 AFE device, which is key to the BodyCom Technology. The LCD bottom line will display “RSSI: XXXX”, this value represents the 10-Bit ADC conversion value used as a RSSI to represent the strength of the signal.

This value will, for the most part, display a range of 0001 to 0003 when no signal is present, when the user makes contact with the coupling pad and thus, the signal pad value will increase, representing noise put on the line by the user.

BodyCom Demonstration Application

By putting a Mobile unit into Continuous Wave, the user can use this debug state to signal strength based on body location, proximity or for receive circuit design debugging.

2.4.2.2 RECEIVE PACKET

The Receive Packet debug menu state is used for debugging with Mobile units or again for receives circuit design. In this mode, the Base unit is put in Continuous Receive mode allowing the mobile to transmit packets continuously to test circuit reception and design.

2.4.2.3 TRANSMIT CONTINUOUS WAVE

The Transmit Continuous Wave debug menu state is used to confirm good operation of the Base unit transmit circuit. This mode allows the user to attach a probe to the signal TX/RX pins to see what strength of the 125 kHz signal the Base station is outputting. The BodyCom Technology system does not require fine LC tuning, the LC circuit in this design is being used as a voltage multiplier but by using the Transmit CW debug mode the user can make modifications which can increase/decrease Q values based on application and design requirements.

2.4.2.4 TRANSMIT LOOPBACK

The Transmit Loopback debug menu state allows the user to pass a string of data with a valid Mobile ID. The LCD will display "Trans Loopback" on the 1st line and "S4 to Start/Stop" on the bottom. To complete a loopback action, the Base unit must first know which mobile to communicate with. To do this, the user must either touch the coupling pad while in possession of a mobile or have the mobile within proximity of the coupling pad before attempting to acquire a mobile to communicate with. By pressing **SELECT (S4)**, the Base unit will ping out for a Mobile unit, when the mobile responds the Base unit will know which ID to address. It will then transmit a string message to the Mobile unit. For this demo, that string is "Loopback Pass"; this message will be displayed on the LCD 2nd line when successful communication is established.

2.4.2.5 TOUCH OPERATION

The Touch Operation debug menu state allows the user to test the functionality of the CVD mTouch scanning in a system. The bottom line of the LCD displays a [R]aw and an [A]verage value from the CVD conversion. The CVD mTouch method is based off the average value recorded, when an increase in the raw value is detected, depending on the shift level, it is registered as a valid touch or as noise. This debug menu should be very helpful in understanding how to integrate the touch feature into a BodyCom Technology application.

2.4.3 View Mobile IDs

Selectable from the main menu, the top line of the LCD will read "Valid Mobile IDs", while the bottom reads "S4 to Enter/Exit". Pressing the **SELECT (S4)** button, the LCD will reflect that the user is viewing valid Mobile IDs related to the specific Base unit. The top line of the LCD will display how many Valid IDs are stored into the unit and which ID value the user is looking at. By using the **UP [S2]** and **DOWN [S3]** button, the user can browse the paired Mobile IDs. By pressing the **SELECT [S4]** button again, the user will exit back to the main menu.

Note: Additional Mobile IDs can be added or existing Mobile IDs can be deleted using the BodyCom Application GUI.

BodyCom™ Development Kit User's Guide

NOTES:

Chapter 3. BodyCom Development Kit Hardware

This chapter provides a more detailed description of the hardware features of the BodyCom Development Kit.

3.1 BASE UNIT HARDWARE FEATURES

The key features of the BodyCom Development Kit are listed below. They are represented in the order given in **Section 1.4 “Development Board Features”** and Figure 1-1.

3.1.1 28-Pin Receptacle Expansion Header

The BodyCom Development Board implements a 28-pin modular expansion interface (J6). This modular expansion is in place to allow future interface expansion for future Microchip demo expansion boards or for use with custom prototype applications. The connector pin assignments for (J6) are shown below in Figure 3-1, also, refer to **Appendix A. “Development Kit Schematics”**. It is recommended that users reference the schematic before using the expansion on the board. This additional modular expansion allows the user to incorporate other Microchip demo boards or all expansion of peripheral features through use of the expansion interface.

FIGURE 3-1: EXPANSION HEADER CALLOUT

1	+ 3.3 V	2	RA5
3	N/C	4	RA4
5	N/C	6	RA3
7	N/C	8	RC5
9	RC7	10	RC4
11	RC6	12	RC3
13	RB7	14	RA0
15	RB6	16	RA1
17	RB5	18	RA2
19	RB4	20	RC0
21	N/C	22	RC1
23	N/C	24	RC2
25	N/C	26	+ 5V
27	N/C	28	GND

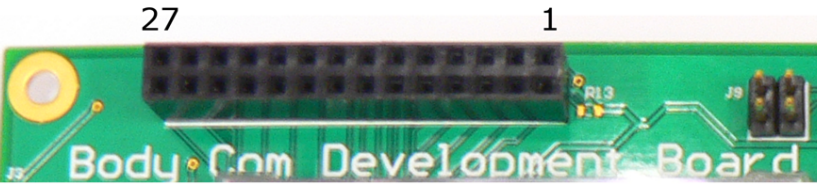

3.1.2 16x2 Character LCD with Controller and Backlight

The board includes the NHD-C0216CiZ-FSW-FBW-3V3 from Newhaven Display International. The screen features the ability to write two lines x 16 characters, runs at 3 VDD with a 3V backlight display supported by two side White LEDs used for backlight.

3.1.3 Selectable External Oscillator Source

The BodyCom Development Board contains two external crystals, which can be used in development of BodyCom Technology applications.

- The external 8.192 MHz (Y2) crystal oscillator is supplied on the board, but is not used in the demonstration program. However, by altering the default jumper configuration and applying a few firmware changes, use of the crystal with the development kit can easily be achieved.
- The external 8.192 MHz (Y3) canned oscillator is supplied on the board and is used by the demonstration program. The crystal is used by the PIC16LF1829 MCU as its clock source. Also, it is used by the Signal Mixer [3.2.5] to mix the mobile response signal of 8 MHz into a 192 kHz signal, which can be received and processed by the MCP 2035 AFE.

3.1.4 PIC16LF1829 20-Pin Flash MCU with XLP Technology

The PIC16LF1829 20-pin SSOP MCU with XLP technology was selected for use with the BodyCom Development Base Board. This device contains a 32 MHz Internal Oscillator Block with three selectable power ranges or can run from an external crystal. This device uses extremely low active currents of 48 μ A/MHz @ 1.8V and up to 20 nA @1.8V during Sleep, while supporting a large list of internal peripheral features such as 10-bit ADC, 5-bit DAC, (2) comparators, DSM, EUSART and more.

3.1.5 Double-balanced Mixer and Oscillator

The Phillips SA612A double-balanced mixer is a low-power VHF monolithic double-balanced mixer with on-board oscillator and voltage regulator. This device supplies a low cost, low-power solution for communication systems. The mixer can operate up to 500 MHz, requires a low amount of external parts, supplies excellent sensitivity, gain and noise protection, while maintaining a low-radiated energy level.

3.1.6 MCP602 CMOS Op Amp

The MCP602 is a low-power dual-operation amplifier which utilizes Microchip's advanced CMOS technology to provide low-bias current, high-speed operation, high open-loop gain, and rail-to-rail output swing. The CMOS can run on as low as 2.7V while drawing around 230 μ A of quiescent current per amplifier.

3.1.7 User-Defined Switches

Three push buttons switches (**SW1/MCLR**, **SW2**, **SW3**) are provided for user-defined digital inputs. They are connected to the I/O pins, MCLR/RG5, RB1 and RB0. When pressed, they pull the respective port pin to ground. Using these switches requires the corresponding pin's internal weak pull-ups be enabled. When the switches are not required, the pull-ups can be disabled. This adds the ability to reduce power consumption in software.

3.1.8 MCP2035 Analog Front End (AFE) Device

The MCP2035 is an Analog Front-End (AFE) optimized for BodyCom applications. It is a single-channel stand-alone device for low-frequency (LF) signal detection and low-power short range transponder applications, such as BodyCom communications. The device can detect an input signal with amplitude as low as ~1 mV_{PP} and can demodulate an amplitude-modulated input signal with as low as 8% modulation depth. The device communicates through a simple Serial Peripheral Interface (SPI), operating with currents typically around 10 μ A and standby currents of 2 μ A.

3.1.9 MCP2200 USB 2.0 to UART Protocol Converter with External Crystal

The MCP2200 is a USB-to-UART serial converter, which enables USB connectivity in application that have an UART interface. The device reduces external components by integrating the USB termination resistors. The MCP2200 also has 256-bytes of integrated user EEPROM. The MCP2200 has eight general purpose input/output pins. Four of the pins have alternate functions to indicate USB and communication status. An external 12 MHz canned oscillator is used as a frequency source.

3.1.10 Selectable Power Sources

The BodyCom Development Board uses two selectable power sources listed below:

- +9V external power supply connected to [J3] with [J2] configured on pins<1:2>. An LDO [3.1.12] is used to create a +5V power rail. Another LDO is used to create a +3.3V power rail for use with the PIC device and other on-board components while using the +5V for the transmit/receive circuit.
- +5V USB cable connected to [J1] with [J2] configured on pins<2:3>. An LDO [3.1.12] is used to create a +3.3V power rail for use with the PIC device while using the +5V for the transmit/receive circuit.

The red LED [D3] will turn on when the board is powered from either source.

3.1.11 ICSP Programmer Header

The 6-pin programmer header (J4) can be used by the PICKit™, PICKit™ 3, and ICD3 programming devices. Through use of the PICKit 3, the user is capable of debugging the included demonstration software or creating and debugging custom software in use with the BodyCom Development Kit.

3.1.12 MCP1703 LDO

The MCP1703 is a CMOS, low dropout voltage regulator with 250 mA maximum output. MCP1703 works with input voltage of up to 16V and in combination with its low-current consumption of 2 μ A is an ideal solution for applications using multi-cell, 9V alkaline or one-cell, two-cell and three-cell lithium-ion batteries.

3.1.13 Generous Prototyping Area

To assist in the development and testing of application hardware, the XLP board includes a 24 x 11 prototype area for the installation of the user's custom circuitry. Sources for the board power V_{DD} and ground are located above the area. Supplied from 19 different I/O signals, the prototyping area supplies a wide range of possible features which can be tested and experimented with from the prototyping area.

BodyCom™ Development Kit User's Guide

3.2 JUMPER CONFIGURATION

The jumper features of the BodyCom Development Kit are listed below. They are represented in the order given in 1.4 “Development Board Features” and Figure 1-3.

3.2.1 Mixer Clock Select

By altering the configuration of this jumper, the user is able to select between two external oscillator sources for use with the BodyCom Development Kit.

- [1:2] – Selects 8.192 MHz crystal oscillator for use.
- [2:3] – Selects 8.192 MHz canned oscillator for use. <Default>

Note: J15, J16, J17, J19 are effected by this jumper configuration.

3.2.2 External Oscillator Enables

Depending on the configuration of [J14] the enable jumpers which must be populated change.

- [J15, J16] – Crystal Oscillator enable jumpers. J14 must be in [pin 1:2] configuration, J17 must be in [pin 2:3] configuration.
- [J17] – Canned Oscillator enable jumper. J14 must be in [pin 2:3] configuration. <Default>

3.2.3 Coupling Pad Prototyping Pins

The [J9] pins are meant to be used for prototyping custom user coupling pads. Prototypes can be added to the [J9] pins while a coupling pad populates [J7, J11] allowing for dual functionality while testing.

FIGURE 3-2: PROTOTYPING PINS

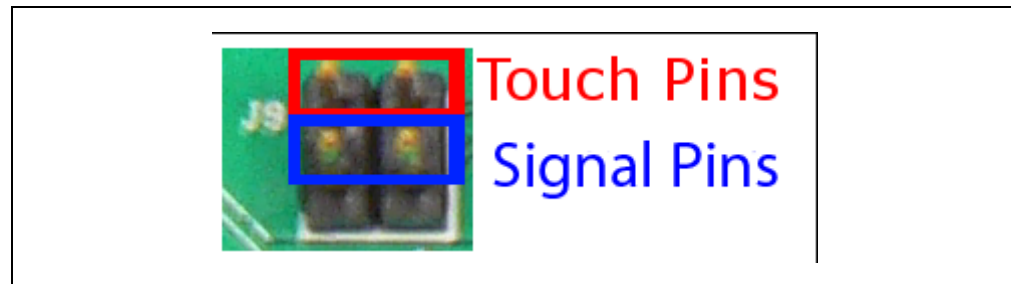

3.2.4 Coupling Pad Connectors

The BodyCom Development Kit includes (2) demonstration coupling pads for use with the Base board. [J7] connects the coupling pad top trace to the touch sensing pin on the device. [J11] connects the coupling pad bottom trace to the signal pin [TX/RX] of the board. Custom coupling pads can also be connected at these points. [J12, J13] DO NOT connect to anything on the coupling pad. They are used for stability only; they DO NOT connect to GND rail.

3.2.5 Base Board Demo Functionality Jumpers

The jumpers on [J8] are used to enable/disable demo board functionality or to be used to breakout connections to prototype designs. All jumpers must be populated for use of the demo application.

- [1:2] – Touch Enable: RC2 is used for Touch detection on [J9 - Top], [J7].
- [3:4] – MOD_OUT: RC3 pin is used to control half LC circuit for LF Driver circuit via on-chip DSM.
- [5:6] – MOD_OUT: RA2 pin is used to control other half of LC circuit for LF Driver via inverted DSM signal.
- [7:8] – SW_DET: RA1 is connected to SW_DET signal and used for push buttons. Refer to [J9 <2:3>].
- [9:10] – Enable_RX: RC7 controls the receive circuit. Required for receiving communication.

3.2.6 Input Select

By altering [J19] configuration of the push button detection pin.

- [1:2] – Configures push button detection on Pin RA1. <Default>
- [2:3] – Configures push button detection on Pin RA4. RA4 is used for OSCO, thus cannot be used for push button detection when using the crystal oscillator configuration.

3.2.7 Bootloader MCP2200 Functionality

The jumpers on [J5] are used to enable/disable bootloader functionality support. All jumpers must be populated for use of GUI or bootloader.

- [1:2] – USART_TX: Connects RC5 to MCP2200 TX pin; RC5 is the alternative RX pin for on-chip USART.
- [3:4] – USART_RX: Connects RC6 to MCP2200 RX pin; RC6 is the alternative TX pin for on-chip USART.
- [5:6] – USART_RTS: Connects RA3[MCLR] to MCP2200 RTS (Request to Send) pin; RA3 is used a software MCLR pin on demo.
- [7:8] – USART_CTS: Connects RC7 to MCP2200 CTS (Clear to Send) pin; RC7 is a GPIO.

3.2.8 Power Supply Select

This jumper selects which power supply the BodyCom Development Board will use.

- [1:2] – Selects +9V external power supply as power source.
- [2:3] – Selects +5V USB cable as power source. <Default>

3.2.9 Touch indicator LED enable

Populating [J18] enables the use of the green LED (D4) through pin RA0. This LED is meant to assist in system debugging or as a functional LED.

3.3 MOBILE UNIT HARDWARE FEATURES

The key features of the BodyCom Mobile Unit are listed below. They are represented in the order given in **Section 1.4 “Development Board Features”** and Figure 1-4.

3.3.1 Battery Clip

The BK-912 is a low height surface mount 2032 coin cell battery holder. The battery clip supplies a reliable connection while fitting to most key fob size standards.

3.3.2 LED Indicators

There are (2) LED indicators populated on the Mobile unit. The green LED (D2) is connected to pin RB7. The red LED (D1) is connected to pin RB6. These LEDs are used in the demo application and are extremely useful when debugging the Mobile unit communication system.

3.3.3 ICSP Programming Pads

Programming Pads on the Mobile unit make updating the firmware or prototyping with custom firmware relatively easy. Head pins can easily be soldered to the pads for quick programming during prototyping. Header pins can also be pressed against these pads to create a connection allowing for non-intrusive re-programming.

3.3.4 Hex Inverter

The Texas Instruments SN74LVC04APWR Hex inverter is used for the LC Driver circuit on the Mobile device. Capable of operating from 1.65 to 3.6V, the circuit is controlled using a single GPIO. This minimizes component counts and circuit complexity.

3.3.5 MCP2035 Analog Front-End (AFE) Device

Refer to 3.1.8.

3.3.6 PIC16LF1827 18-Pin Flash MCU with XLP Technology

The PIC16LF1827 18-pin SSOP MCU with XLP technology was selected for use with the BodyCom Mobile Unit. This device contains a 32 MHz Internal Oscillator Block with three selectable power ranges or can run from an external crystal. This device uses extremely low active currents of 75 μ A/MHz @ 1.8V and up to 30 nA @1.8V during Sleep, while supporting a large list of internal peripheral features such as, 10-bit ADC, 5-bit DAC, (2) comparators, DSM, EUSART and more.

3.3.7 Mobile Module and Coupling Pad

The BodyCom Mobile Unit has been designed so that a Mobile module, which contains all circuitry, can be “sandwiched” with any form of a coupling pad. In the BodyCom Kit design, the coupling pad has the battery clip attached to a supply power [TP2 – +3.3V, TP3 – GND] along with a single signal connector [TP1]. This allows for expanding Mobile unit designs.

3.3.8 Key Fob Casing

The Mobile unit is contained inside the key fob FB-20 series from PolyCase with a single button option. The case has had very small modifications made to it in order to better accommodate the battery clip and over all stability of the Coupling Pad inside the case. BodyCom Technology can be made to accommodate a large number of case solutions depending on the application approach and design.

Appendix A. Development Kit Schematics

The following schematic diagrams are included in this appendix:

- Figure A-1: Schematic for BodyCom Development Board
- Figure A-2: Schematic for BodyCom Module
- Figure A-3: Schematic for BodyCom Capacitive Pad

BodyCom™ Development Kit User's Guide

FIGURE A-1: BodyCom DEVELOPMENT BOARD (1 OF 3)

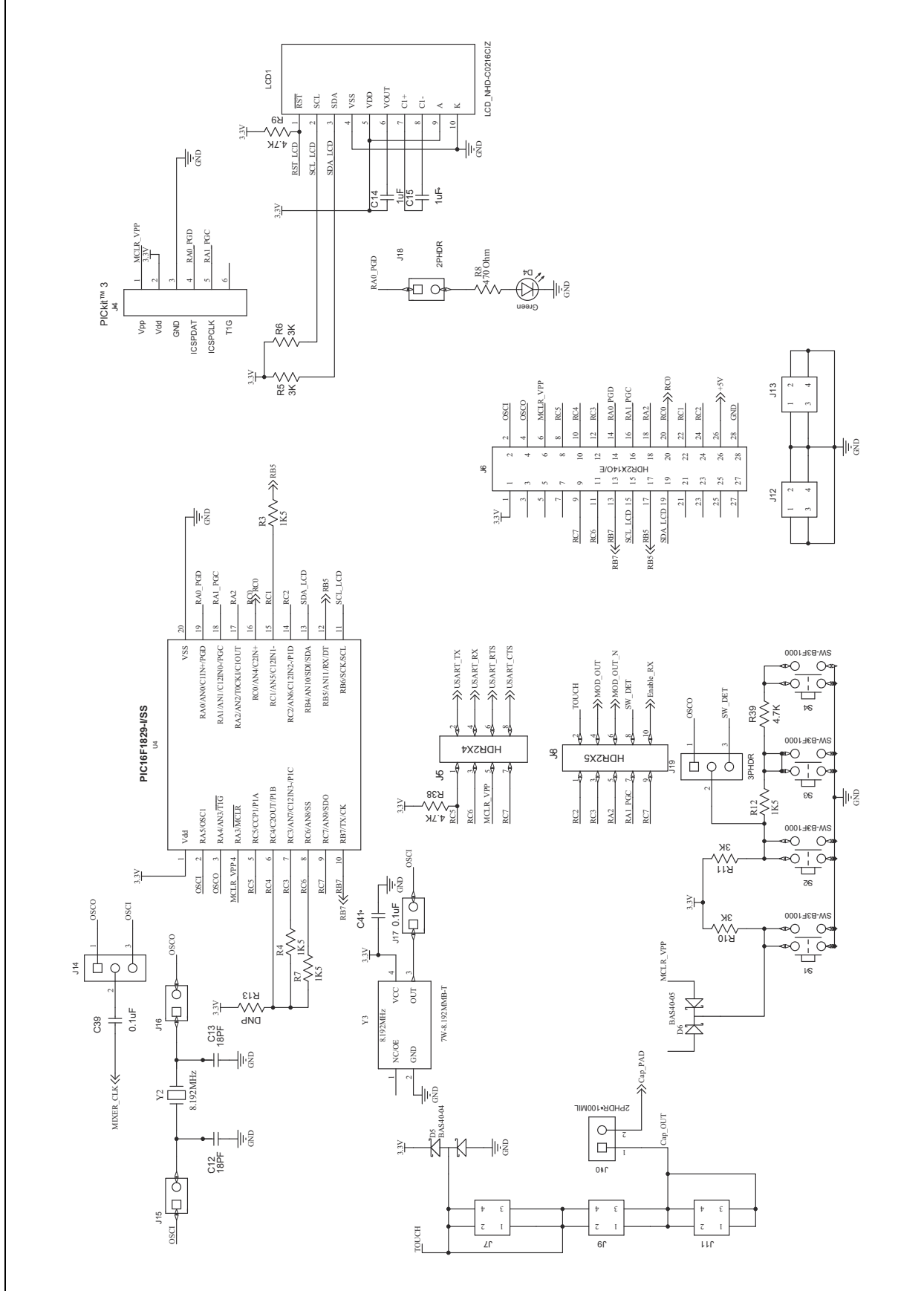
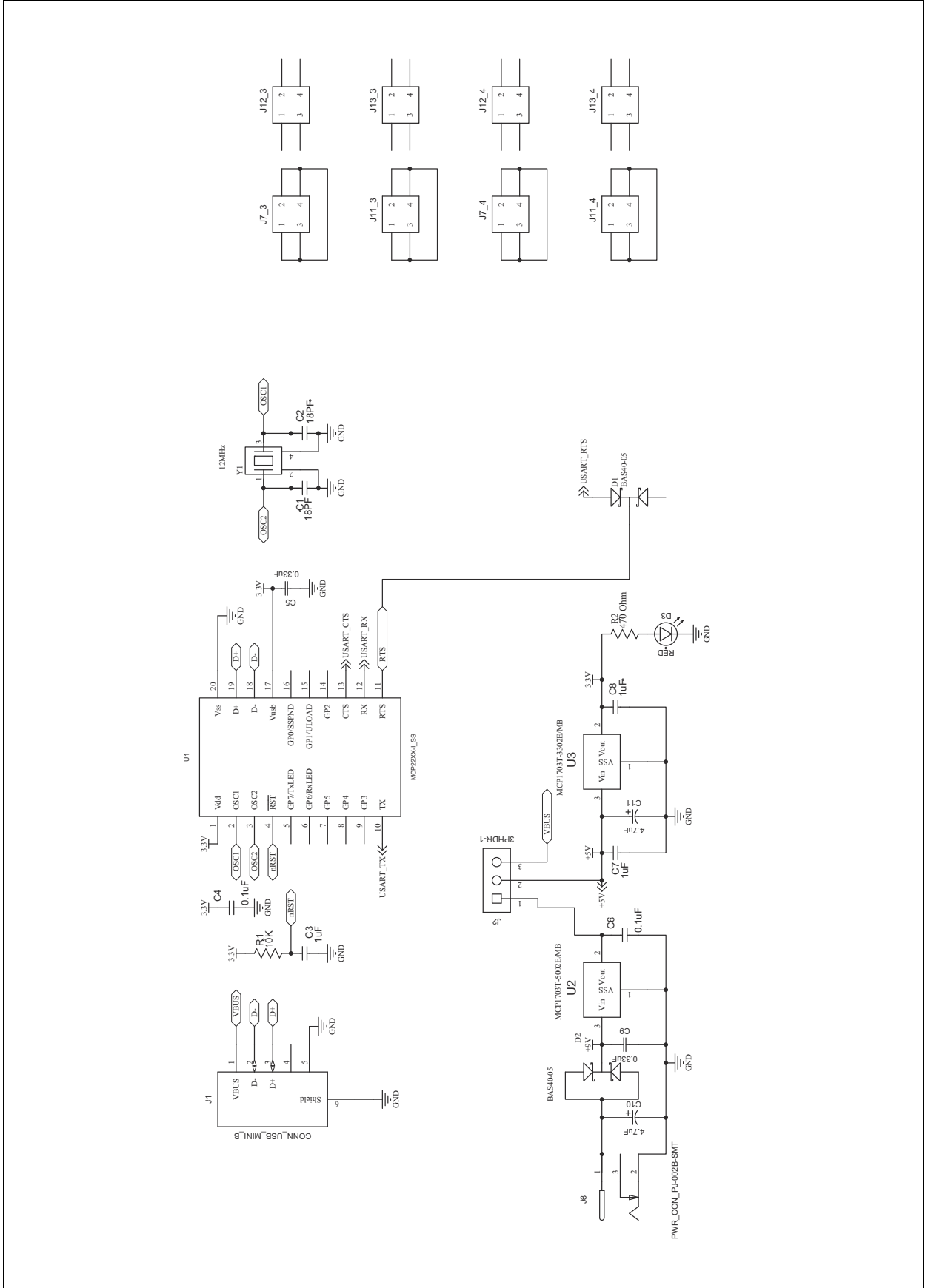

FIGURE A-2: BodyCom DEVELOPMENT BOARD (2 OF 3)



BodyCom™ Development Kit User's Guide

FIGURE A-3: BodyCom DEVELOPMENT BOARD (3 OF 3)

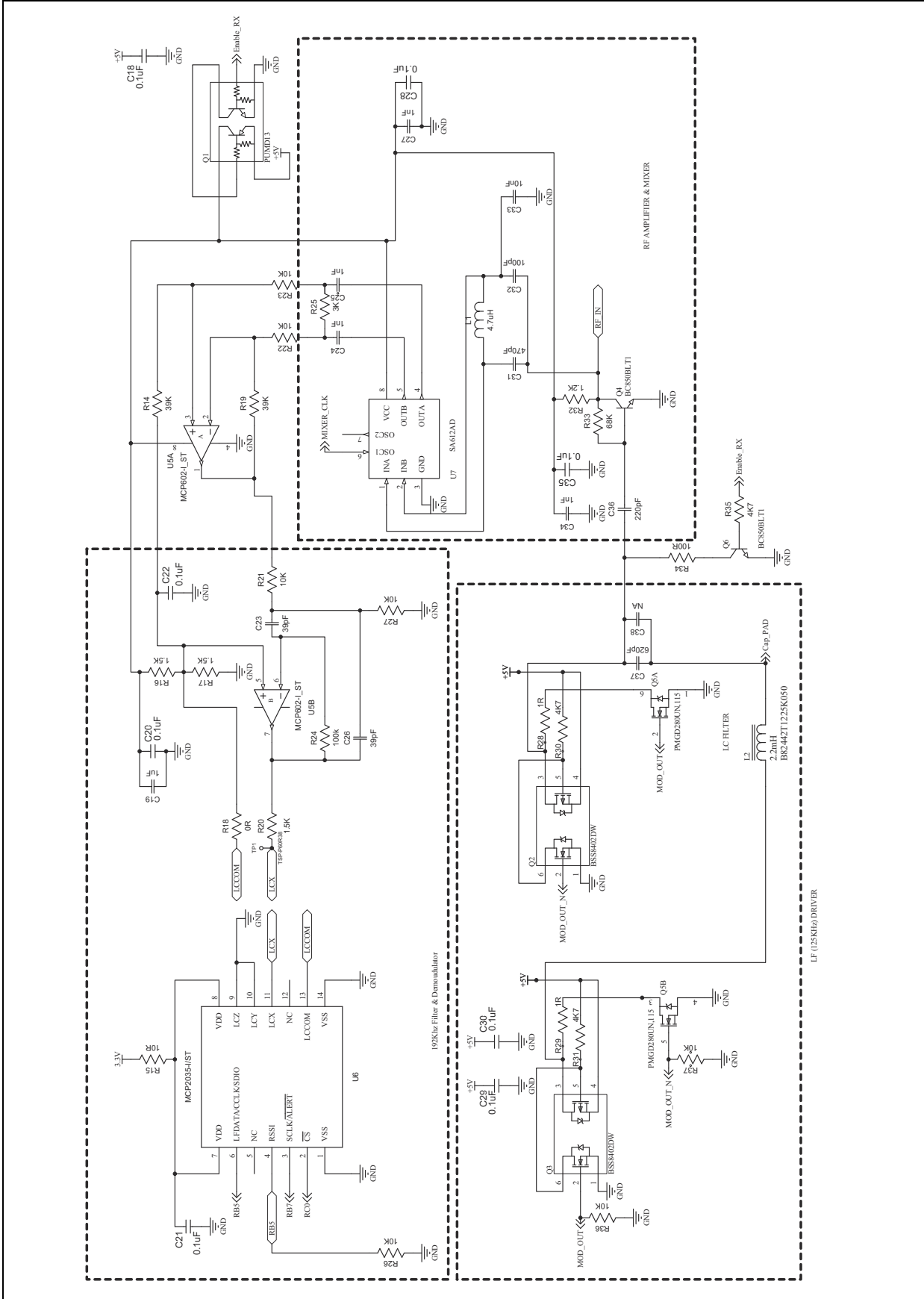
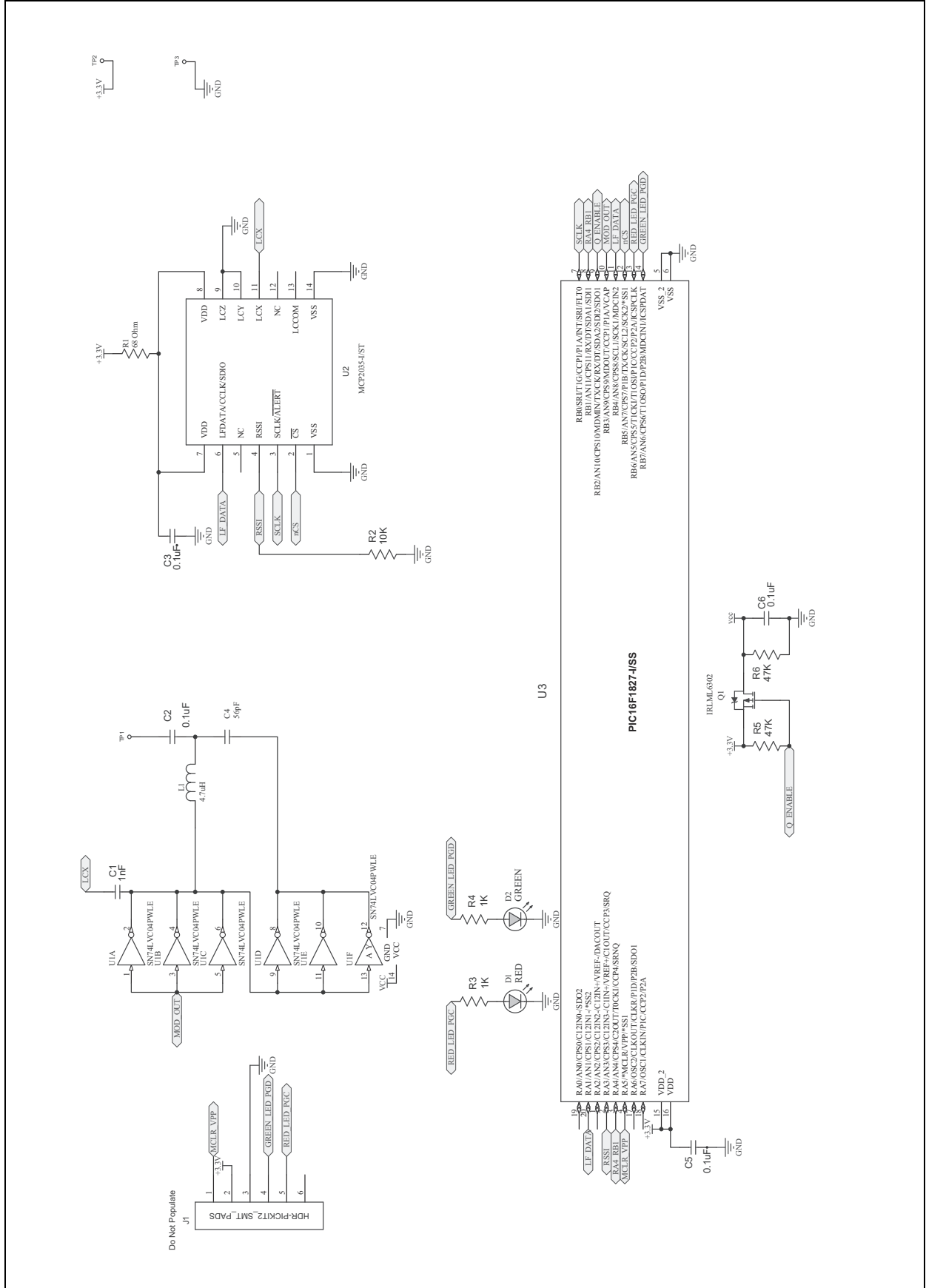
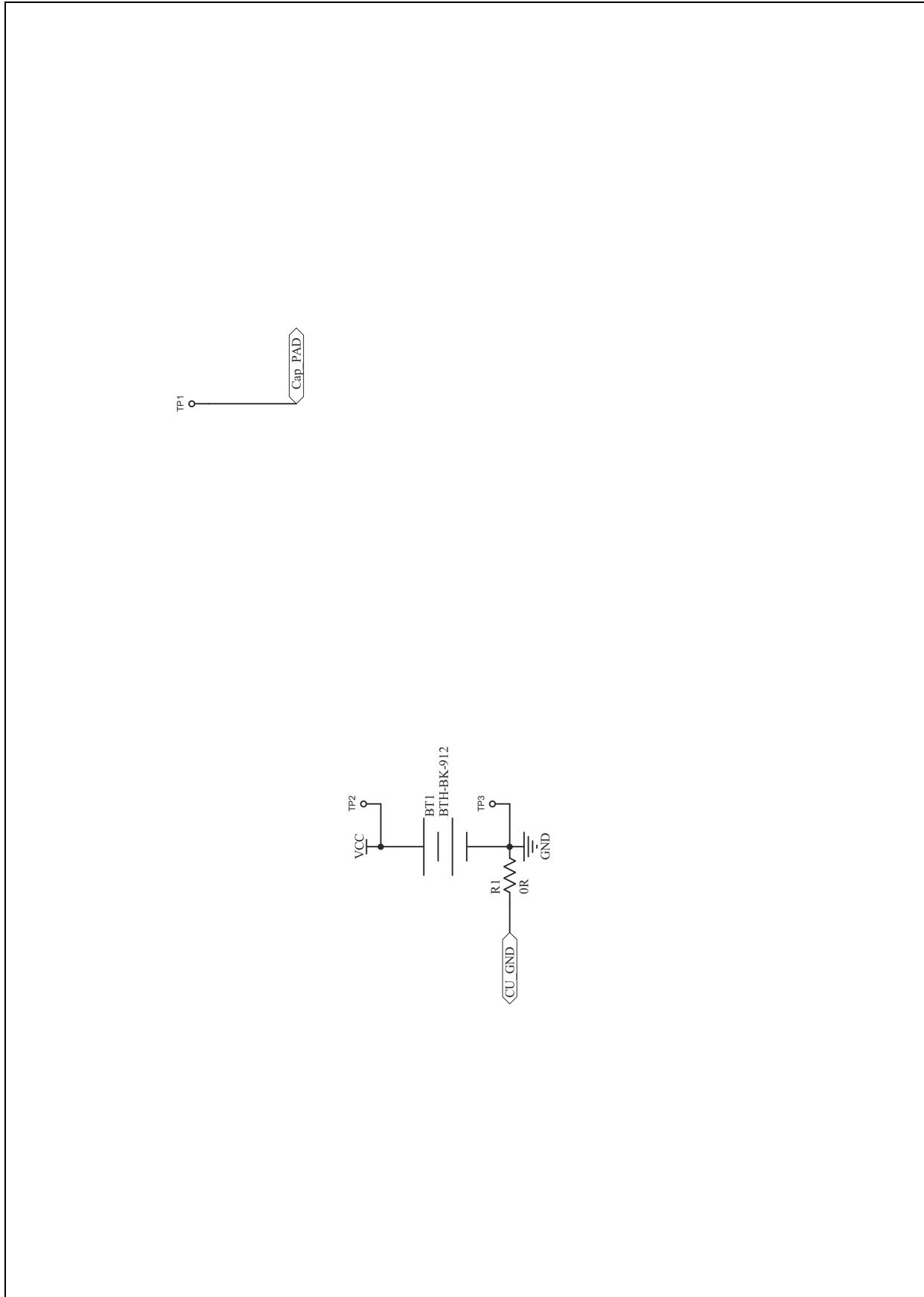

FIGURE A-4: BodyCom MODULE



BodyCom™ Development Kit User's Guide

FIGURE A-5: BodyCom CAPACITIVE PAD



BodyCom™ Development Kit User's Guide

NOTES:



MICROCHIP

Worldwide Sales and Service

AMERICAS

Corporate Office
2355 West Chandler Blvd.
Chandler, AZ 85224-6199
Tel: 480-792-7200
Fax: 480-792-7277
Technical Support:
<http://www.microchip.com/support>
Web Address:
www.microchip.com

Atlanta
Duluth, GA
Tel: 678-957-9614
Fax: 678-957-1455

Boston
Westborough, MA
Tel: 774-760-0087
Fax: 774-760-0088

Chicago
Itasca, IL
Tel: 630-285-0071
Fax: 630-285-0075

Cleveland
Independence, OH
Tel: 216-447-0464
Fax: 216-447-0643

Dallas
Addison, TX
Tel: 972-818-7423
Fax: 972-818-2924

Detroit
Farmington Hills, MI
Tel: 248-538-2250
Fax: 248-538-2260

Indianapolis
Noblesville, IN
Tel: 317-773-8323
Fax: 317-773-5453

Los Angeles
Mission Viejo, CA
Tel: 949-462-9523
Fax: 949-462-9608

Santa Clara
Santa Clara, CA
Tel: 408-961-6444
Fax: 408-961-6445

Toronto
Mississauga, Ontario,
Canada
Tel: 905-673-0699
Fax: 905-673-6509

ASIA/PACIFIC

Asia Pacific Office
Suites 3707-14, 37th Floor
Tower 6, The Gateway
Harbour City, Kowloon
Hong Kong
Tel: 852-2401-1200
Fax: 852-2401-3431

Australia - Sydney
Tel: 61-2-9868-6733
Fax: 61-2-9868-6755

China - Beijing
Tel: 86-10-8569-7000
Fax: 86-10-8528-2104

China - Chengdu
Tel: 86-28-8665-5511
Fax: 86-28-8665-7889

China - Chongqing
Tel: 86-23-8980-9588
Fax: 86-23-8980-9500

China - Hangzhou
Tel: 86-571-2819-3187
Fax: 86-571-2819-3189

China - Hong Kong SAR
Tel: 852-2943-5100
Fax: 852-2401-3431

China - Nanjing
Tel: 86-25-8473-2460
Fax: 86-25-8473-2470

China - Qingdao
Tel: 86-532-8502-7355
Fax: 86-532-8502-7205

China - Shanghai
Tel: 86-21-5407-5533
Fax: 86-21-5407-5066

China - Shenyang
Tel: 86-24-2334-2829
Fax: 86-24-2334-2393

China - Shenzhen
Tel: 86-755-8864-2200
Fax: 86-755-8203-1760

China - Wuhan
Tel: 86-27-5980-5300
Fax: 86-27-5980-5118

China - Xian
Tel: 86-29-8833-7252
Fax: 86-29-8833-7256

China - Xiamen
Tel: 86-592-2388138
Fax: 86-592-2388130

China - Zhuhai
Tel: 86-756-3210040
Fax: 86-756-3210049

ASIA/PACIFIC

India - Bangalore
Tel: 91-80-3090-4444
Fax: 91-80-3090-4123

India - New Delhi
Tel: 91-11-4160-8631
Fax: 91-11-4160-8632

India - Pune
Tel: 91-20-2566-1512
Fax: 91-20-2566-1513

Japan - Osaka
Tel: 81-6-6152-7160
Fax: 81-6-6152-9310

Japan - Tokyo
Tel: 81-3-6880-3770
Fax: 81-45-471-6122

Korea - Daegu
Tel: 82-53-744-4301
Fax: 82-53-744-4302

Korea - Seoul
Tel: 82-2-554-7200
Fax: 82-2-558-5932 or
82-2-558-5934

Malaysia - Kuala Lumpur
Tel: 60-3-6201-9857
Fax: 60-3-6201-9859

Malaysia - Penang
Tel: 60-4-227-8870
Fax: 60-4-227-4068

Philippines - Manila
Tel: 63-2-634-9065
Fax: 63-2-634-9069

Singapore
Tel: 65-6334-8870
Fax: 65-6334-8850

Taiwan - Hsin Chu
Tel: 886-3-5778-366
Fax: 886-3-5770-955

Taiwan - Kaohsiung
Tel: 886-7-213-7828
Fax: 886-7-330-9305

Taiwan - Taipei
Tel: 886-2-2508-8600
Fax: 886-2-2508-0102

Thailand - Bangkok
Tel: 66-2-694-1351
Fax: 66-2-694-1350

EUROPE

Austria - Wels
Tel: 43-7242-2244-39
Fax: 43-7242-2244-393

Denmark - Copenhagen
Tel: 45-4450-2828
Fax: 45-4485-2829

France - Paris
Tel: 33-1-69-53-63-20
Fax: 33-1-69-30-90-79

Germany - Munich
Tel: 49-89-627-144-0
Fax: 49-89-627-144-44

Italy - Milan
Tel: 39-0331-742611
Fax: 39-0331-466781

Netherlands - Drunen
Tel: 31-416-690399
Fax: 31-416-690340

Spain - Madrid
Tel: 34-91-708-08-90
Fax: 34-91-708-08-91

UK - Wokingham
Tel: 44-118-921-5869
Fax: 44-118-921-5820

11/27/12