

2.4-2.5 GHz / 4.9-5.8 GHz Dual-Band Power Amplifier Module

SST13LP05



Data Sheet

FEATURES:

- **High Gain:**
 - Typically 29 dB gain across 2.4-2.5 GHz
 - Typically 29-26 dB gain across 4.9-5.8 GHz
- **High linear output power:**
 - >25 dBm P1dB (Pulsed single-tone signal) across 2.4-2.5 GHz
 - Meets 802.11b OFDM ACPR requirement up to 23.5 dBm across 2.4-2.5 GHz
 - Meets 802.11g OFDM ACPR requirement up to 23 dBm across 2.4-2.5 GHz
 - Added EVM ~4% up to 19 dBm for 54 Mbps 802.11g signal across 2.4-2.5 GHz
 - >24 dBm P1dB across 4.9-5.8 GHz
 - Meets 802.11a OFDM ACPR requirement up to 22.5 dBm across 4.9-5.8 GHz
 - Added EVM ~4% up to 18 dBm for 54 Mbps 802.11a signal across 4.9-5.8 GHz
- **High power-added efficiency/Low operating current for 802.11a/b/g applications**
 - ~160 mA @ $P_{OUT} = 19$ dBm for 802.11g
 - ~235 mA @ $P_{OUT} = 23.5$ dBm for 802.11b
 - ~270 mA @ $P_{OUT} = 18$ dBm for 802.11a
- **Built-in Ultra-low I_{REF} power-up/down control**
 - $I_{REF} < 2$ mA
- **High-speed power-up/down**
 - Turn on/off time (10%-90%) <100 ns
 - Typical power-up/down delay with driver delay included <200 ns
- **High temperature stability**
 - ~1 dB gain/power variation between 0°C to +85°C across 2.4-2.5 GHz
 - ~3/1 dB gain/max linear power variation between 0°C to +85°C across 4.9-5.8 GHz
 - ± 0.5 dB detector variation between 0°C to +85°C
- **Low shut-down current (< 2 μ A)**
- **20 dB dynamic range on-chip power detection**
- **Built-in input/output matching**
- **Packages available**
 - 16-contact LGA package (4mm x 4mm)
- **All non-Pb (lead-free) devices are ROHS compliant.**

APPLICATIONS:

- WLAN (IEEE 802.11a/g/b)
- Japanese WLAN
- HyperLAN2
- Multimedia
- Home RF
- Cordless phones

PRODUCT DESCRIPTION

The SST13LP05 is a fully matched, dual-band power amplifier module (PAM) based on the highly-reliable InGaP/GaAs HBT technology. This PAM provides excellent RF performance, temperature-stable power detectors, and low-current analog on/off control interfaces. The SST13LP05 provides stable RF and power detector performance over a large V_{CC} power supply variation, with an ultra-low shut-down current.

With a near-zero Rest of Bill of Materials (RBOM), the SST13LP05 is designed for 802.11a/b/g applications covering frequency bands 2.4-2.5 GHz and 4.9-5.8 GHz for U.S., European, and Japanese markets.

The SST13LP05 has excellent linearity, typically 4% added Error Vector Magnitude (EVM) at 19 dBm output power. This output power is essential for 54 Mbps 802.11g operation while meeting 802.11g spectrum mask at 23 dBm and 802.11b spectrum mask at 23.5 dBm. For 802.11a opera-

tion, the SST13LP05 typically demonstrates <4% added EVM at 18 dBm output power while meeting 802.11a spectrum mask at 22.5 dBm.

The SST13LP05 also has wide-range (>20 dB), temperature-stable (± 0.5 dB across 0°C to +85°C), directionally-coupled, power detectors which provide a reliable and cost-effective solution to board-level power control. The device's analog on/off control can be driven by an analog or digital control signal from either a transceiver or baseband chip.

These features, coupled with low operating current, make the SST13LP05 ideal for the final stage power amplification in both battery-powered 802.11a/b/g WLAN transmitters and access point applications.

The SST13LP05 is offered in a 16-contact LGA package. See Figure 2 for pin assignments and Table 1 for pin descriptions.



2.4-2.5 GHz / 4.9-5.8 GHz Dual-Band Power Amplifier SST13LP05

Data Sheet

FUNCTIONAL BLOCKS

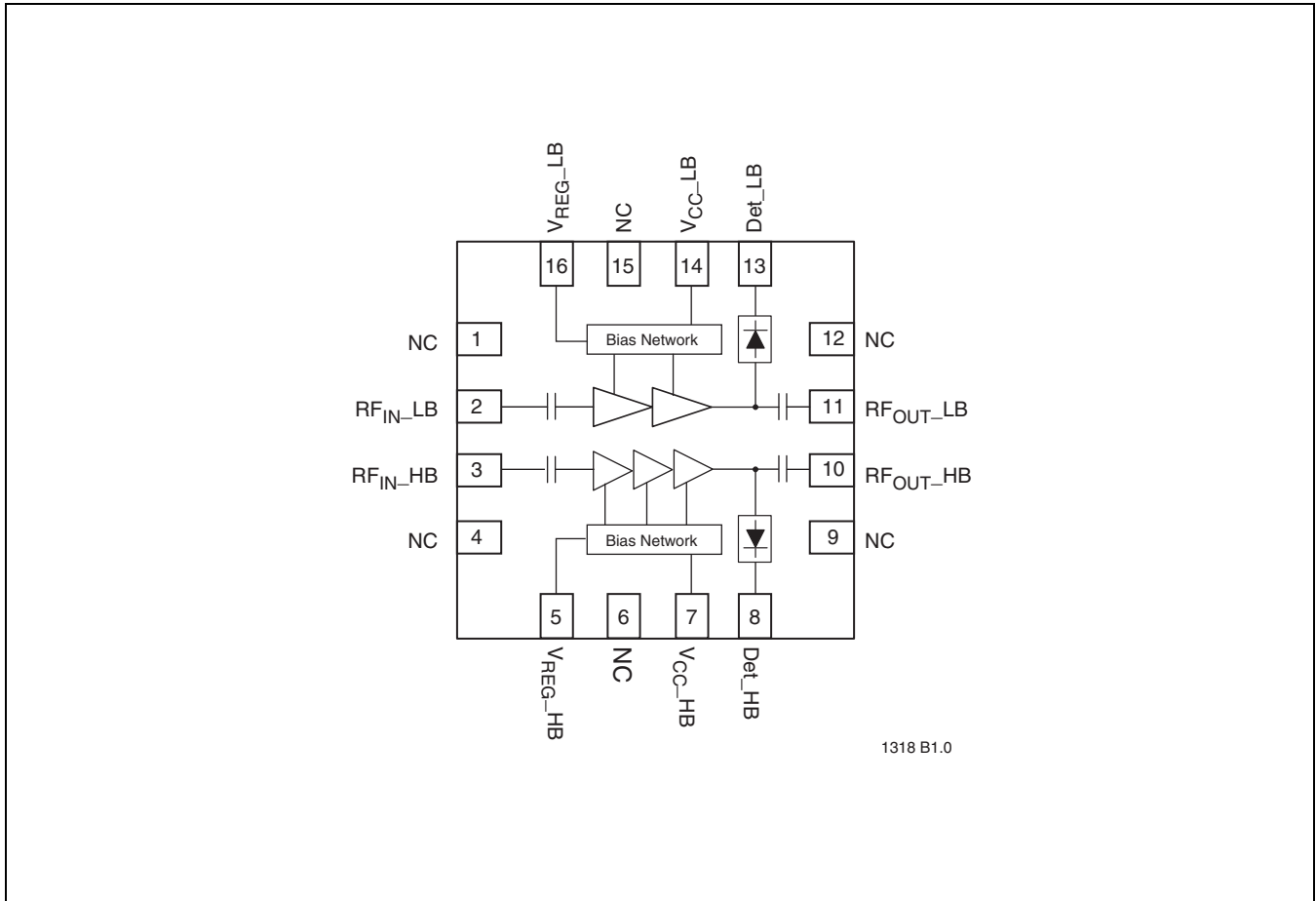

FIGURE 1: Functional Block Diagram

PIN ASSIGNMENTS

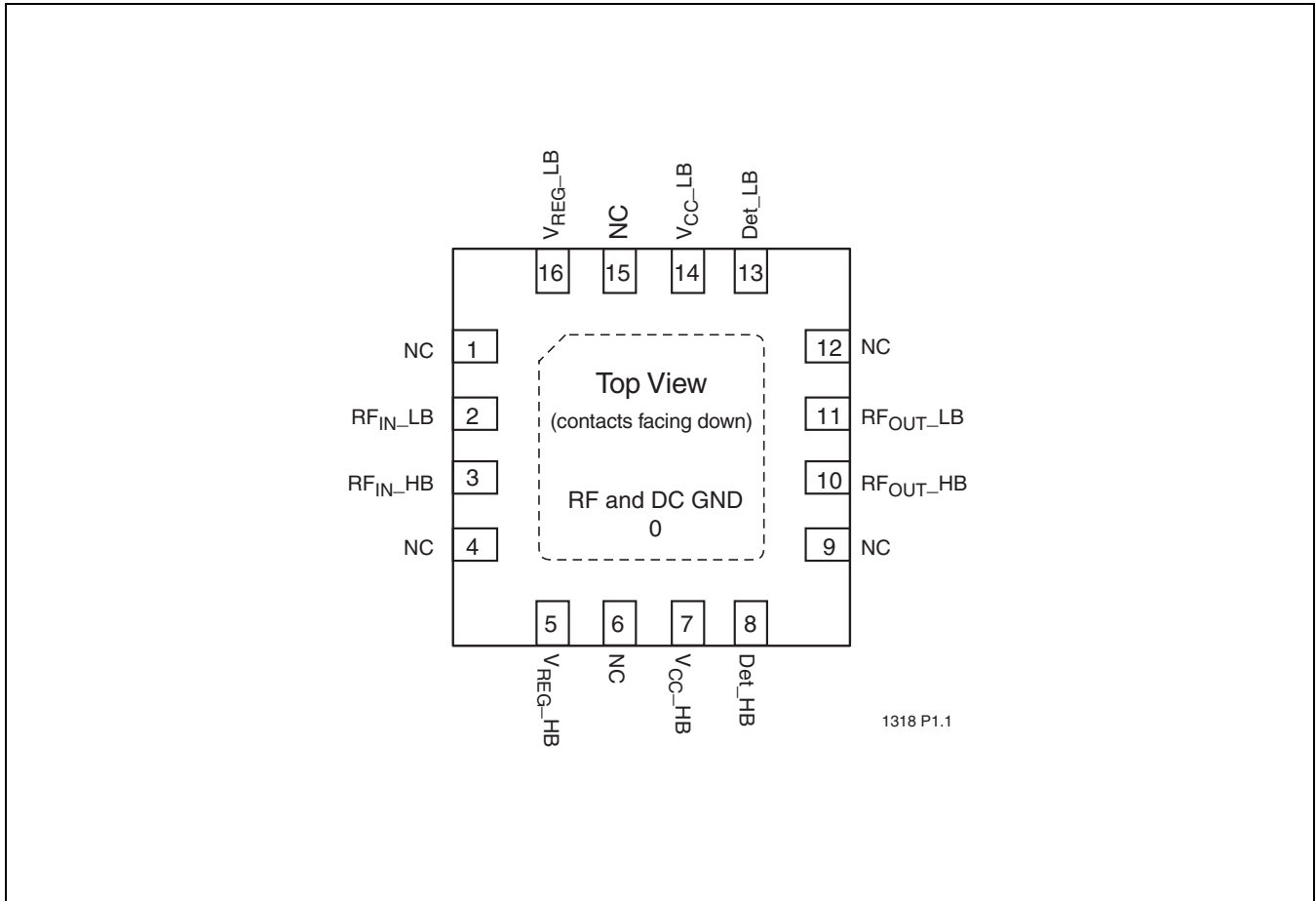

FIGURE 2: Pin Assignments for 16-contact LGA



2.4-2.5 GHz / 4.9-5.8 GHz Dual-Band Power Amplifier SST13LP05

Data Sheet

PIN DESCRIPTIONS

TABLE 1: Pin Description

Symbol	Pin No.	Pin Name	Type	Function
GND	0	Ground		Ground Pad
NC	1	No Connection		Unconnected Pin
RF _{IN} _LB	2		I	50Ω Matched RF Input for Low Band, AC coupled
RF _{IN} _HB	3		I	50Ω Matched RF Input for High Band, AC coupled
NC	4	No Connection		Unconnected Pin
V _{REG} _HB	5	Power Supply	PWR	Analog current control for High Band
NC	6	No Connection		Unconnected Pin
V _{CC} _HB	7	Power Supply	PWR	V _{CC} Power Supply for High Band
D _{ET} _HB	8		O	Detector Voltage Output for High Band
NC	9	No Connection		Unconnected Pin
RF _{OUT} _HB	10	Power Supply	O/PWR	50Ω Matched RF output for High Band
RF _{OUT} _LB	11	Power Supply	O/PWR	50Ω Matched RF output for Low Band
NC	12	No Connection		Unconnected Pin
D _{ET} _LB	13		O	Detector Voltage Output for Low Band
V _{CC} _LB	14	Power Supply	PWR	V _{CC} Power Supply for Low Band
NC	15	No Connection		Unconnected Pin
V _{REG} _LB	16	Power Supply	PWR	Analog current control for Low Band

T1.0 1318

2.4-2.5 GHz / 4.9-5.8 GHz Dual-Band Power Amplifier

SST13LP05



Data Sheet

ELECTRICAL SPECIFICATIONS

The AC and DC specifications for the power amplifier interface signals. Refer to Tables 2 and 4 for the DC voltage and current specifications. Refer to Figures 3 through 22 for the RF performance.

Absolute Maximum Stress Ratings Applied conditions greater than those listed under “Absolute Maximum Stress Ratings” may cause permanent damage to the device. This is a stress rating only and functional operation of the device at these conditions or conditions greater than those defined in the operational sections of this data sheet is not implied. Exposure to absolute maximum stress rating conditions may affect device reliability.

Supply Voltage (V_{CC})	-0.3V to +3.6V
Reference Voltage (V_{REF})	-0.3V to +3.3V
DC supply current (I_{CC})	400 mA
Operating Temperature (T_A)	-40°C to +85°C
Storage Temperature (T_{STG})	-40°C to +120°C
Maximum Junction Temperature (T_J)	+150°C



2.4-2.5 GHz / 4.9-5.8 GHz Dual-Band Power Amplifier SST13LP05

Data Sheet

For 802.11b/g Operation

TABLE 2: DC Electrical Characteristics

Symbol	Parameter	Min.	Typ	Max.	Unit
V _{CC}	Supply Voltage	3.0	3.3	3.6	V
I _{CC}	Supply Current				
	for 802.11g, 19 dBm		160		mA
	for 802.11b, 23.5 dBm		235		mA
I _{REG}	Analog control current at On state			2	mA
V _{REG}	Reference Voltage		2.95		V

T2.0 1318

TABLE 3: AC Electrical Characteristics for Configuration

Symbol	Parameter	Min.	Typ	Max.	Unit
F _{L-U}	Frequency range	2.4		2.5	GHz
G	Small signal gain	28	29		dB
G _{VAR1}	Gain variation over temperature 0°C – 85°C	-1		1	dB
G _{VAR2}	Gain flatness over any 50 MHz bandwidth	-0.3		0.3	dB
ACPR	Meet 11b spectrum mask	22	23		dBm
	Meet 11g OFDM 54 Mbps spectrum mask	22	23		dBm
Added EVM	P _{OUT} = 19 dBm with 54Mbps			-28	dB
	11g OFDM signal when operating at 3.3V Vcc			4	%
2f, 3f, 4f, 5f	Harmonics at P _{OUT} = 20 dBm			-50	dBc
	Spurious non-harmonics at P _{OUT} = 20 dBm			-60	dBc
	In/Out return loss at 50 Ω nominal impedance	6			dB

T3.0 1318

2.4-2.5 GHz / 4.9-5.8 GHz Dual-Band Power Amplifier SST13LP05



Data Sheet

For 802.11a Operation

TABLE 4: DC Electrical Characteristics

Symbol	Parameter	Min.	Typ	Max.	Unit
V _{CC}	Supply Voltage	3	3.3	3.6	V
I _{CC}	Supply Current for 802.11a, 18 dBm		270		mA
I _{REG}	Analog control current at On state			2	μA
V _{REG}	Reference Voltage		2.95		V

T4.1 1318

TABLE 5: AC Electrical Characteristics for Configuration

Symbol	Parameter	Min.	Typ	Max.	Unit
F _{L-U}	Frequency range	4.92		5.805	GHz
G	Small signal gain across 4.9- 5.8 GHz	26			dB
G _{VAR1}	Gain variation over temperature 0°C – 85°C	-1		1	dB
G _{VAR2}	Gain flatness over any 100 MHz bandwidth	-0.5		0.5	dB
ACPR	Meet 11a OFDM 54 Mbps spectrum mask	22	22.5		dBm
Added EVM	P _{OUT} = 18 dBm with 54Mbps 11aOFDM signal when operating at 3.3V Vcc			-28	dB
2f, 3f, 4f, 5f	Harmonics at 20 dBm			4	%
				-45	dBc

T5.1 1318



2.4-2.5 GHz / 4.9-5.8 GHz Dual-Band Power Amplifier SST13LP05

Data Sheet

Typical Low Band Performance for 802.11b/g

Test Conditions: $V_{CC} = 3.3V$, $T_A = 25^\circ C$, $V_{REF} = 2.95V$ unless otherwise noted

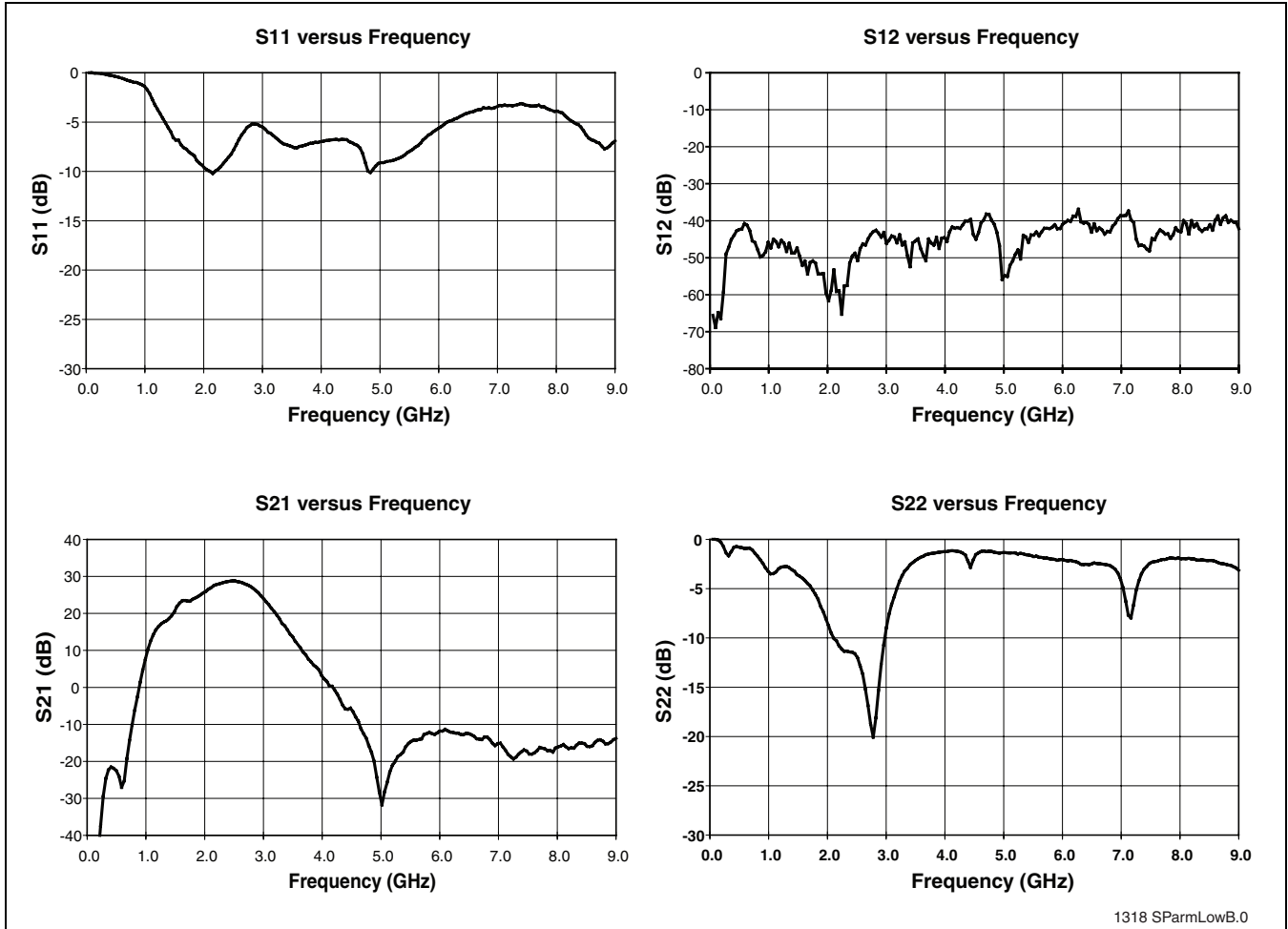

FIGURE 3: Low Band S-Parameters

2.4-2.5 GHz / 4.9-5.8 GHz Dual-Band Power Amplifier SST13LP05



Data Sheet

Test Conditions: $V_{CC} = 3.3\text{ V}$, $V_{REF} = 2.95\text{ V}$, 54 Mbps 802.11g OFDM signal

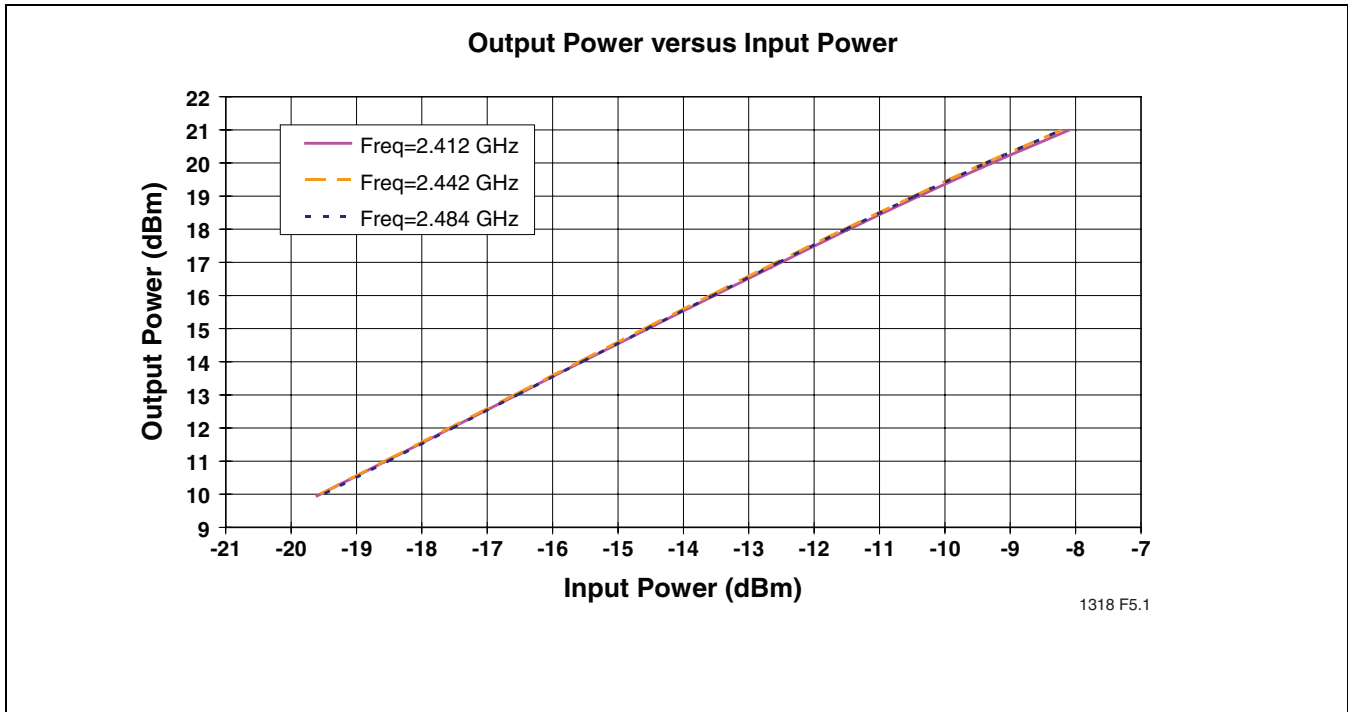

FIGURE 4: Low Band Output Power versus Input Power

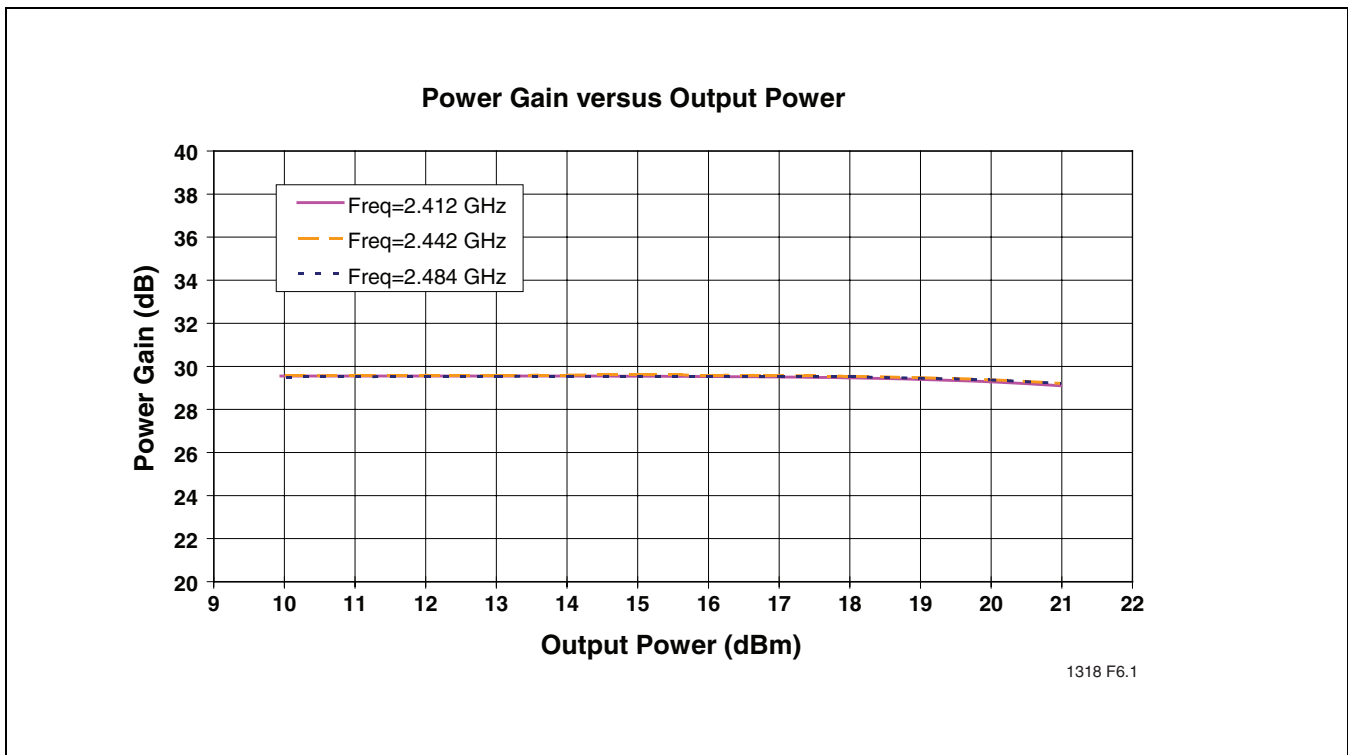

FIGURE 5: Low Band Power Gain versus Output Power

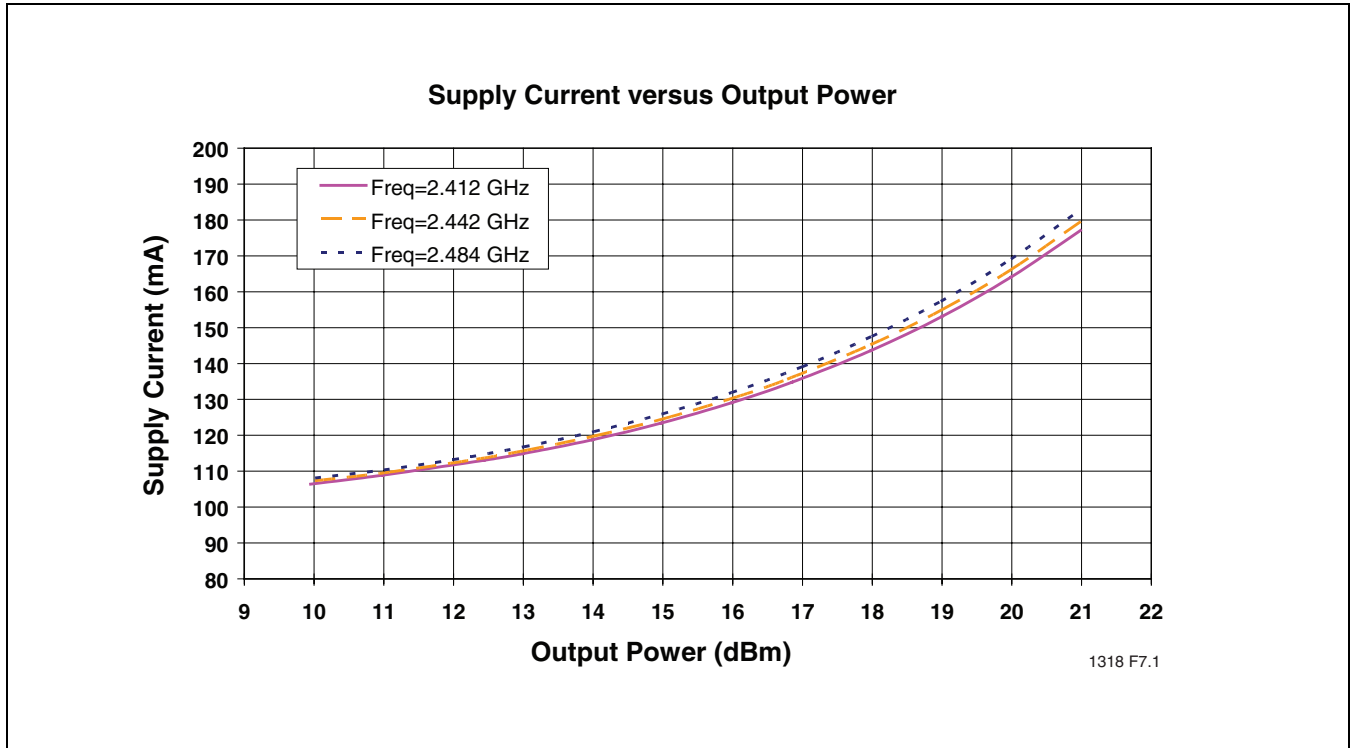

FIGURE 6: Low Band Supply Current versus Output Power

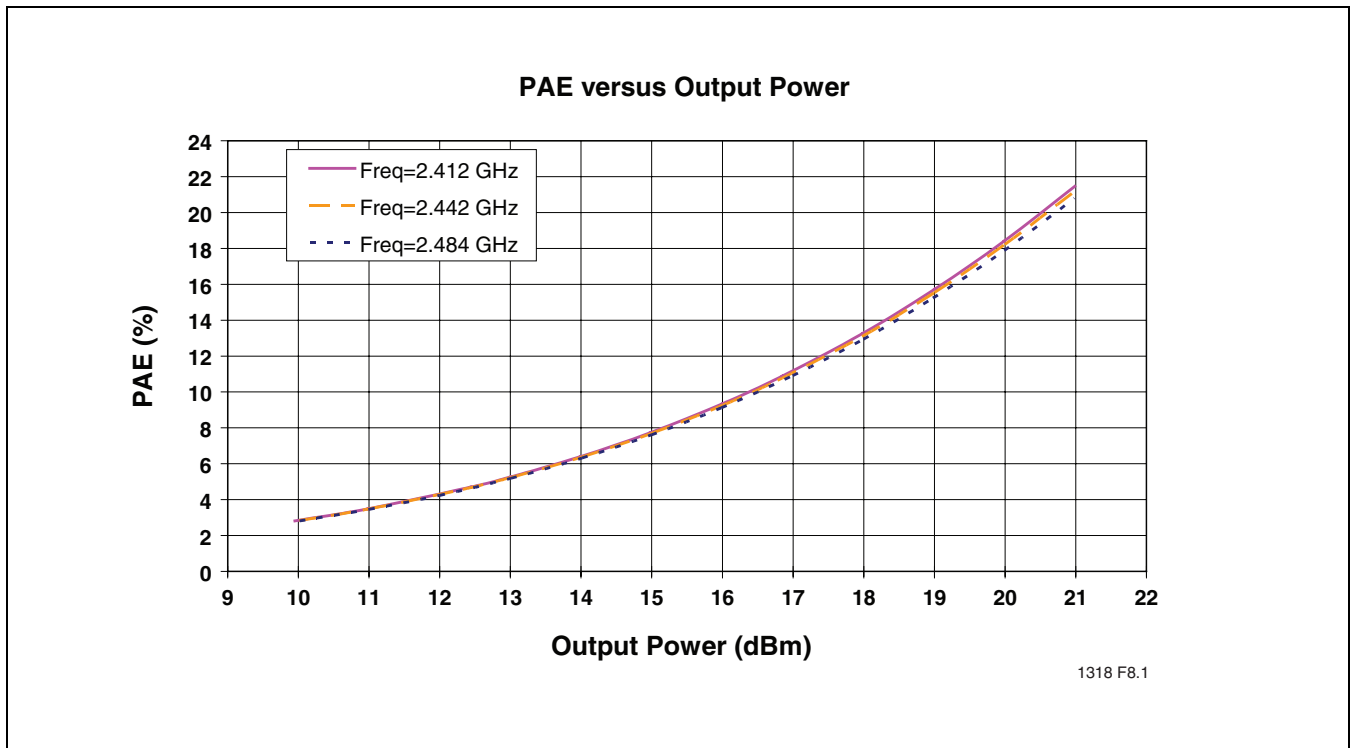

FIGURE 7: Low Band PAE versus Output Power

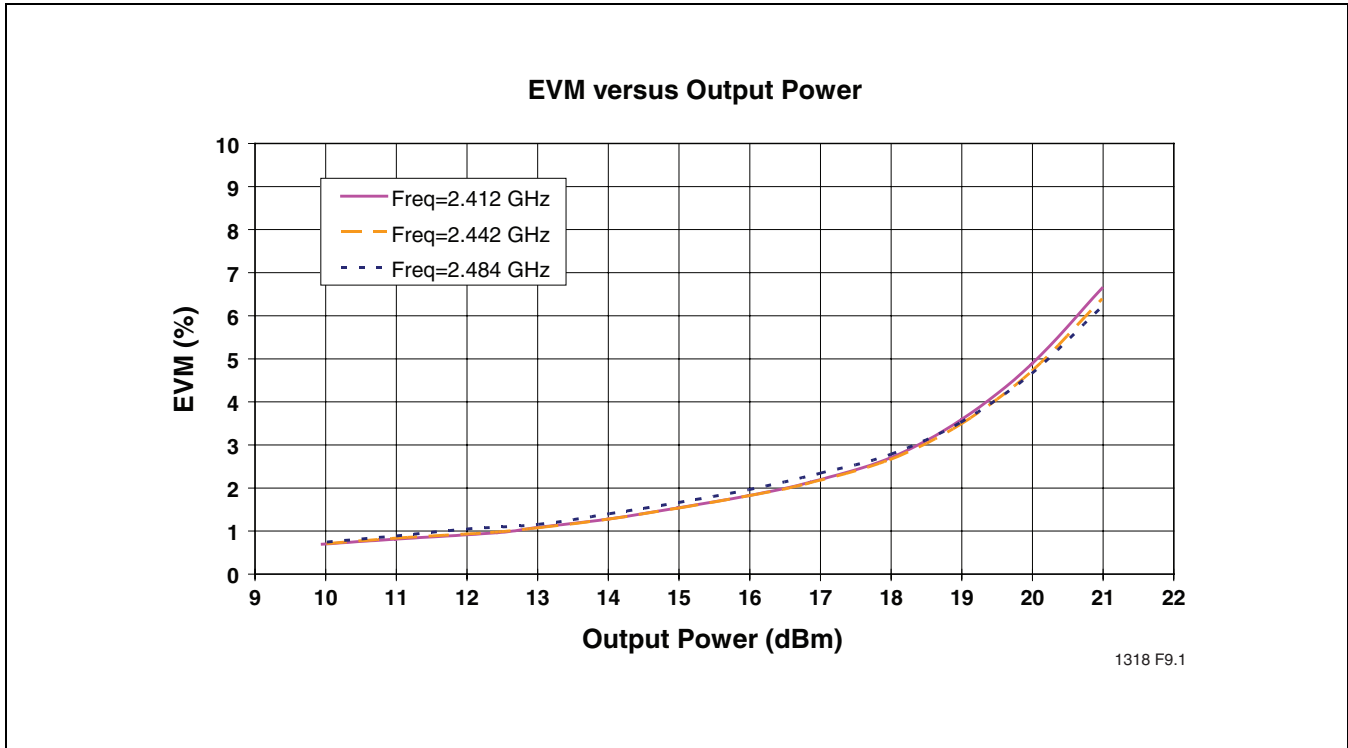

FIGURE 8: Low Band EMV versus Output Power

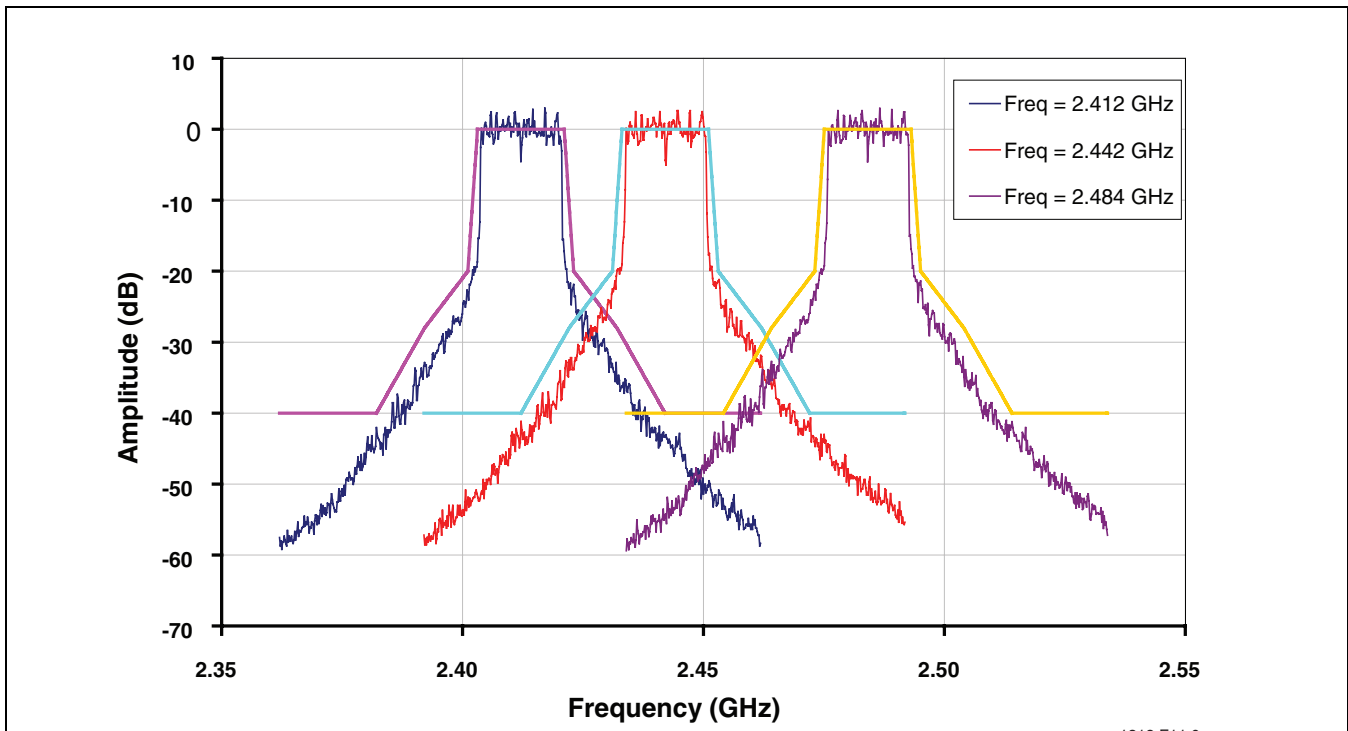

FIGURE 9: Low Band 802.11b Spectrum Mask at 23 dBm with DC Current of 220 mA



2.4-2.5 GHz / 4.9-5.8 GHz Dual-Band Power Amplifier SST13LP05

Data Sheet

Test Conditions: $V_{CC} = 3.3V$, $V_{REF} = 2.95V$, $T_A = 25^\circ C$, 1 Mbps 802.11b CCK Signal

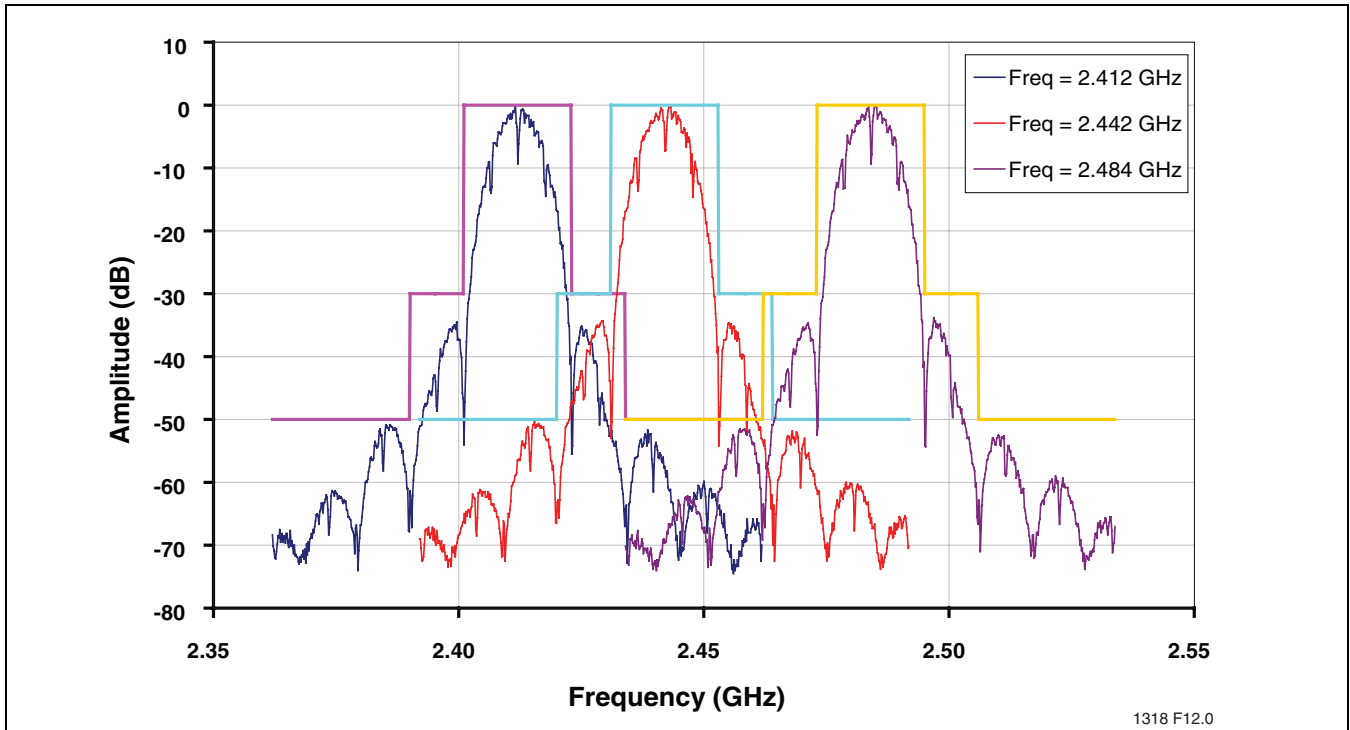

FIGURE 10: Low Band 802.11b Spectrum Mask at 23.5 dBm with DC Current of 235 mA



Low Band Power Detector Characteristics

Test Conditions: $V_{CC} = 3.3V$, $V_{REF} = 2.95V$, $T_A = 25^\circ C$, 54 Mbps 802.11g OFDM Signal

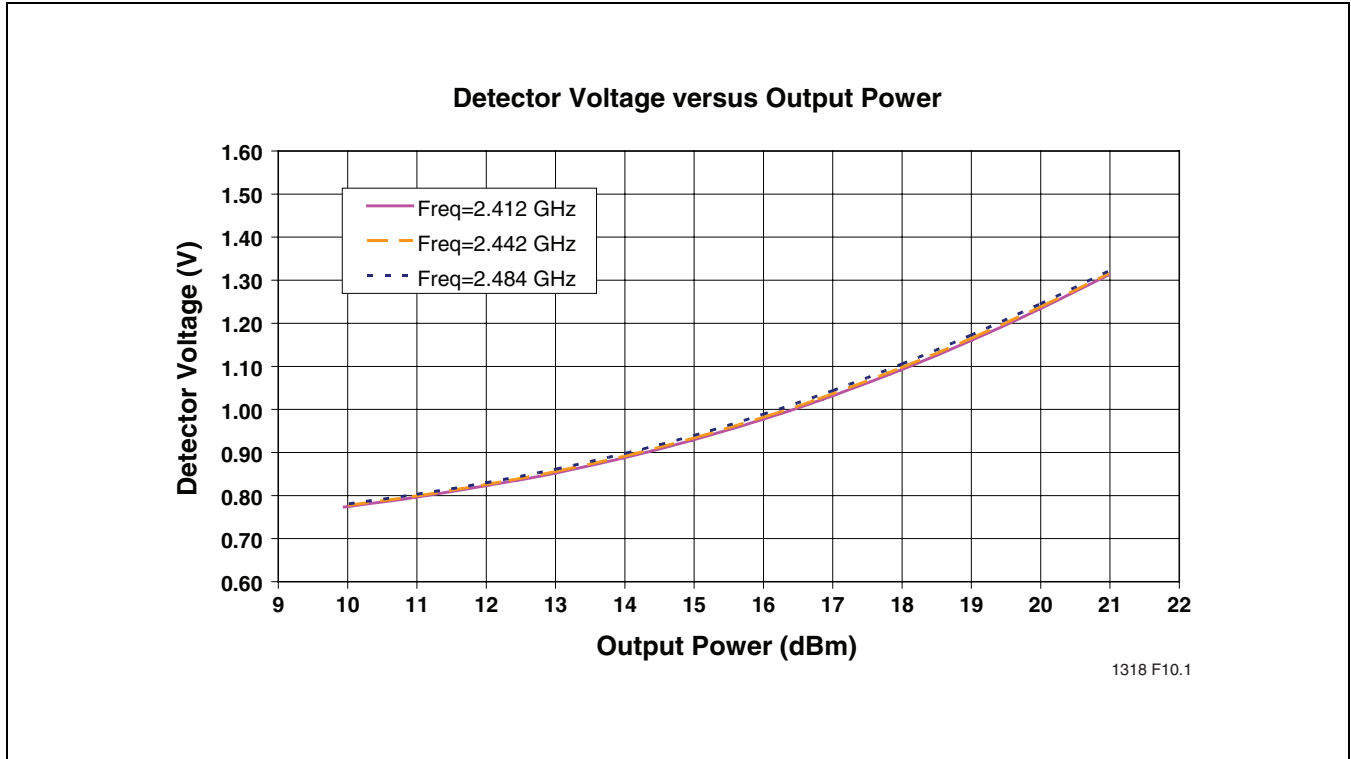

FIGURE 11: Low Band Detector Voltage versus Output Power



2.4-2.5 GHz / 4.9-5.8 GHz Dual-Band Power Amplifier SST13LP05

Data Sheet

Typical High Band Performance for 802.11a

Test Conditions: $V_{CC} = 3.3V$, $T_A = 25^\circ C$, $V_{REF} = 2.95V$ unless otherwise noted

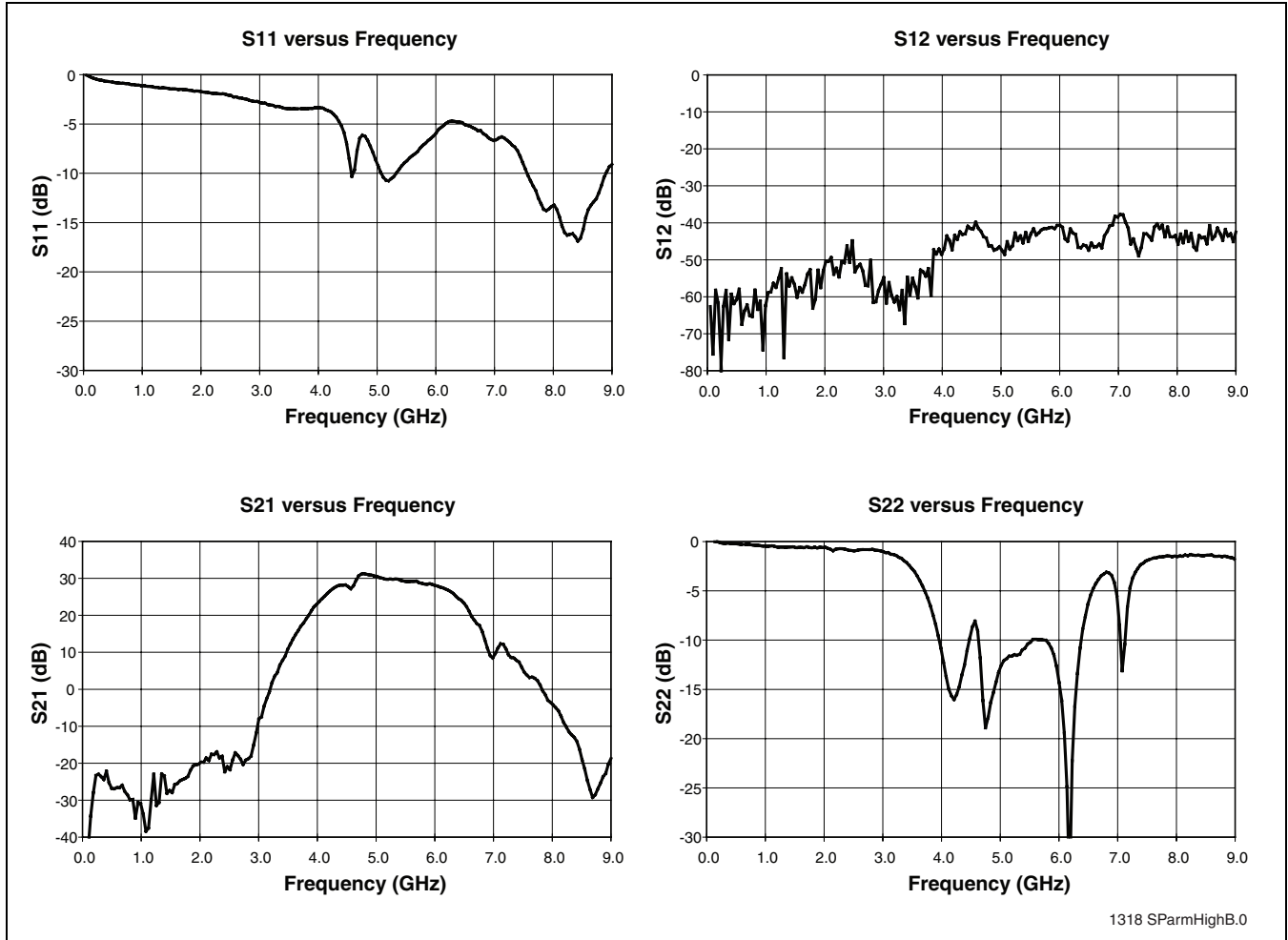

FIGURE 12: High Band S-Parameters

2.4-2.5 GHz / 4.9-5.8 GHz Dual-Band Power Amplifier

SST13LP05



Data Sheet

Test Conditions: $V_{CC} = 3.3V$, $V_{REF} = 2.95V$, 54 Mbps 802.11a OFDM Signal

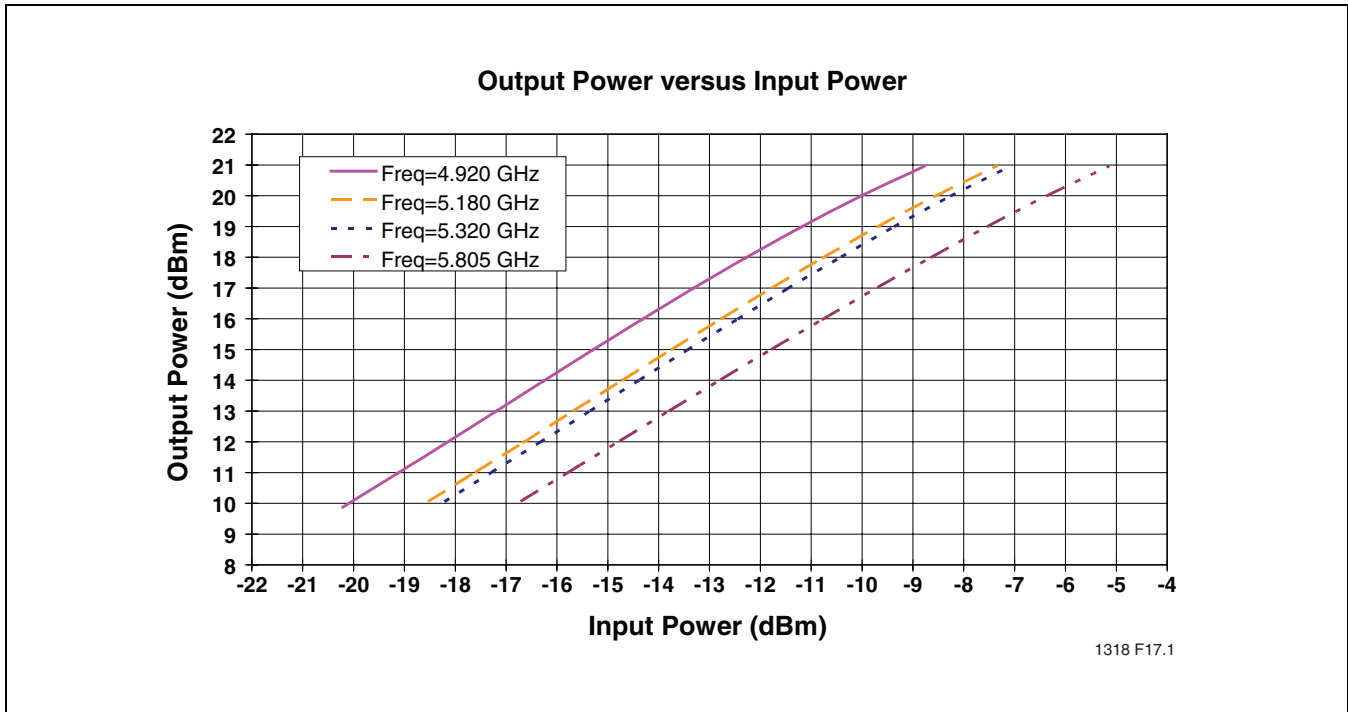

FIGURE 13: High Band Output Power versus Input Power

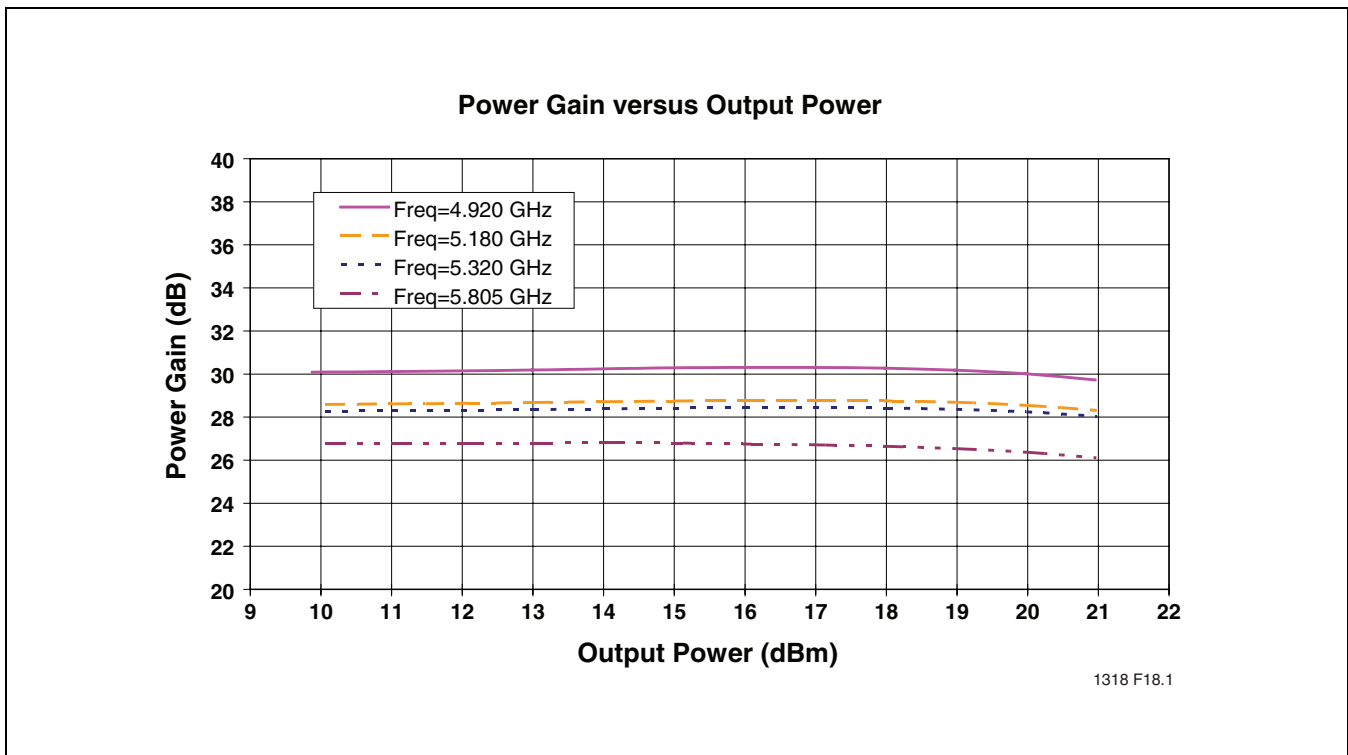

FIGURE 14: High Band Power Gain versus Output Power

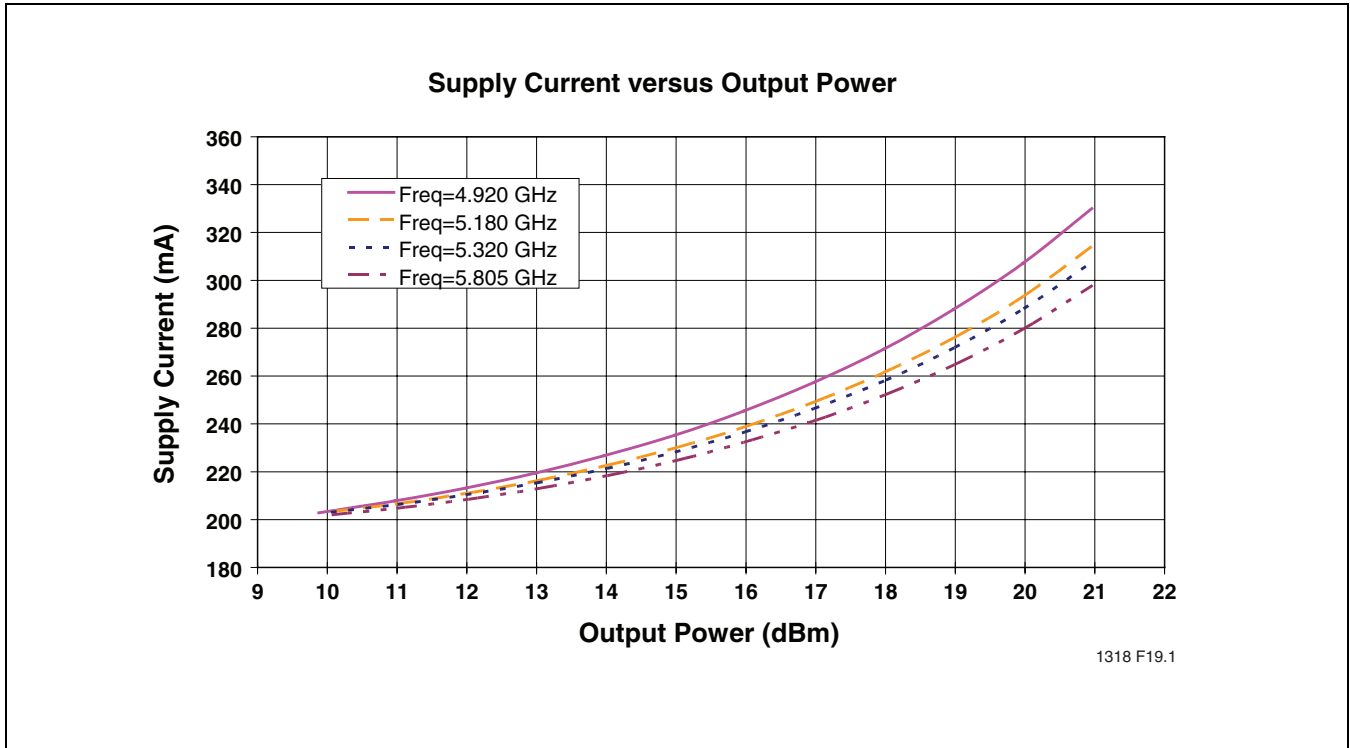

FIGURE 15: High Band Supply Current versus Output Power

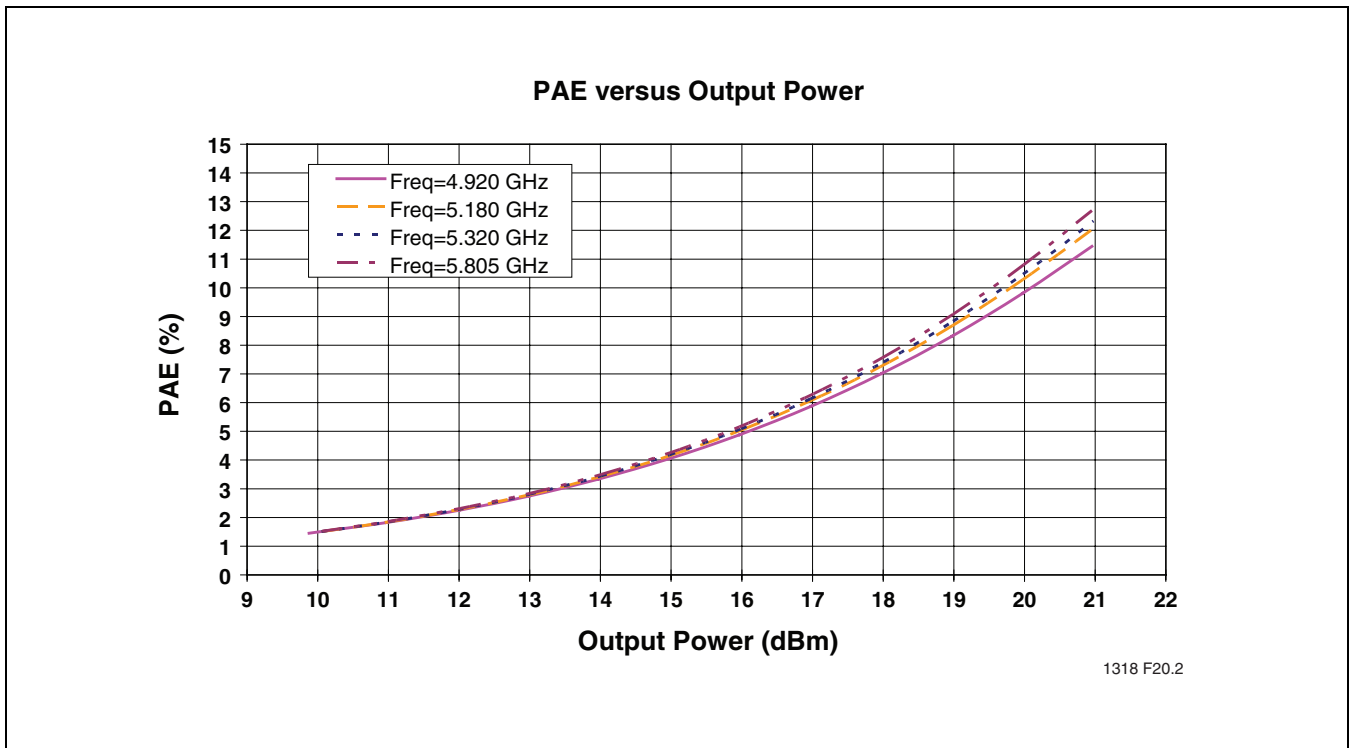

FIGURE 16: High Band PAE versus Output Power

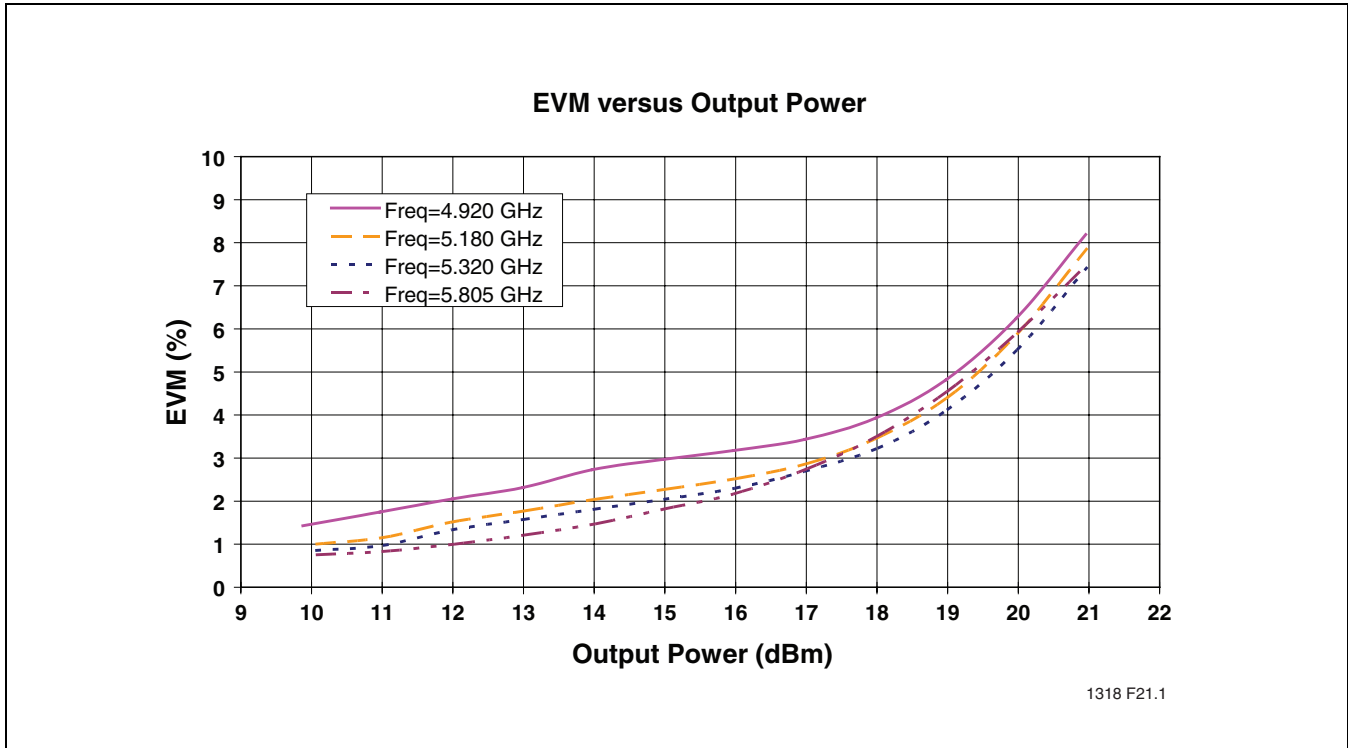

FIGURE 17: High Band EVM versus Output Power

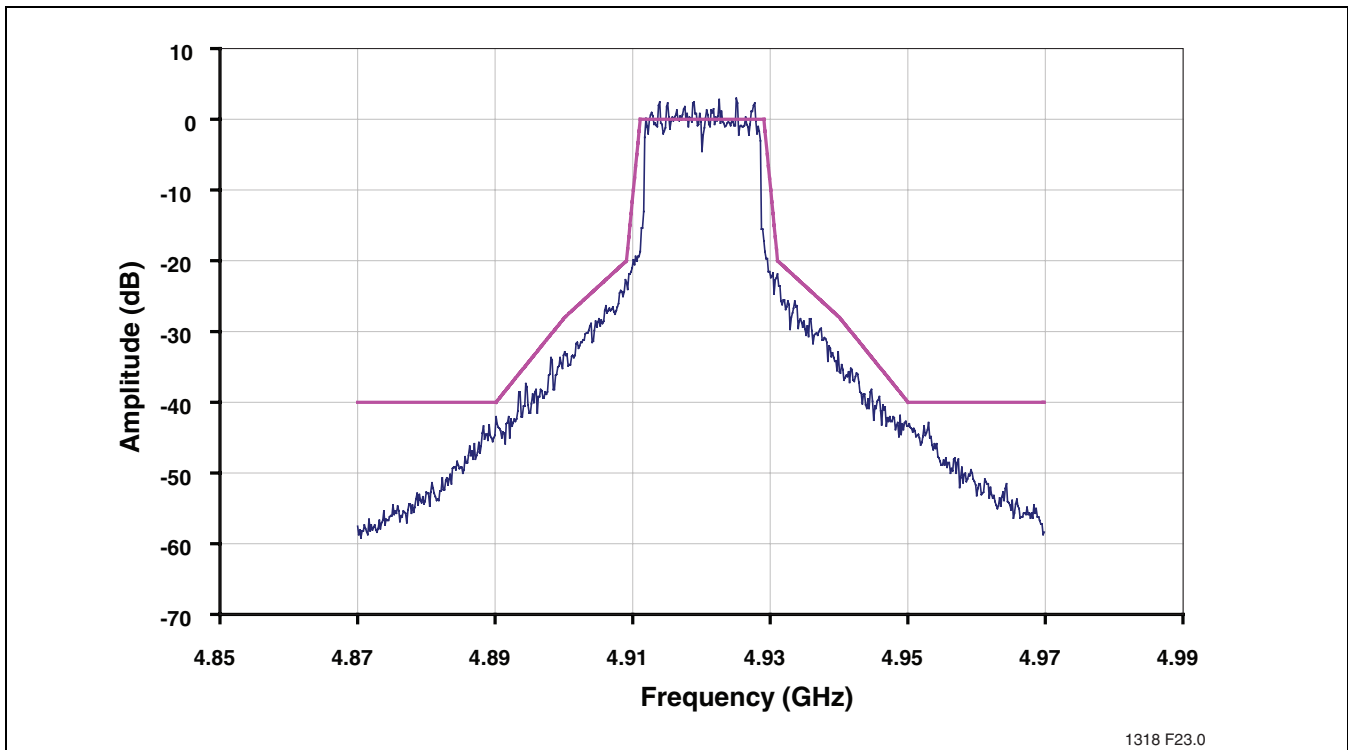

FIGURE 18: High Band 802.11a Spectrum Mask at 4.92 GHz at Output Power 22.5 dBm with DC Current at 370 mA



2.4-2.5 GHz / 4.9-5.8 GHz Dual-Band Power Amplifier SST13LP05

Data Sheet

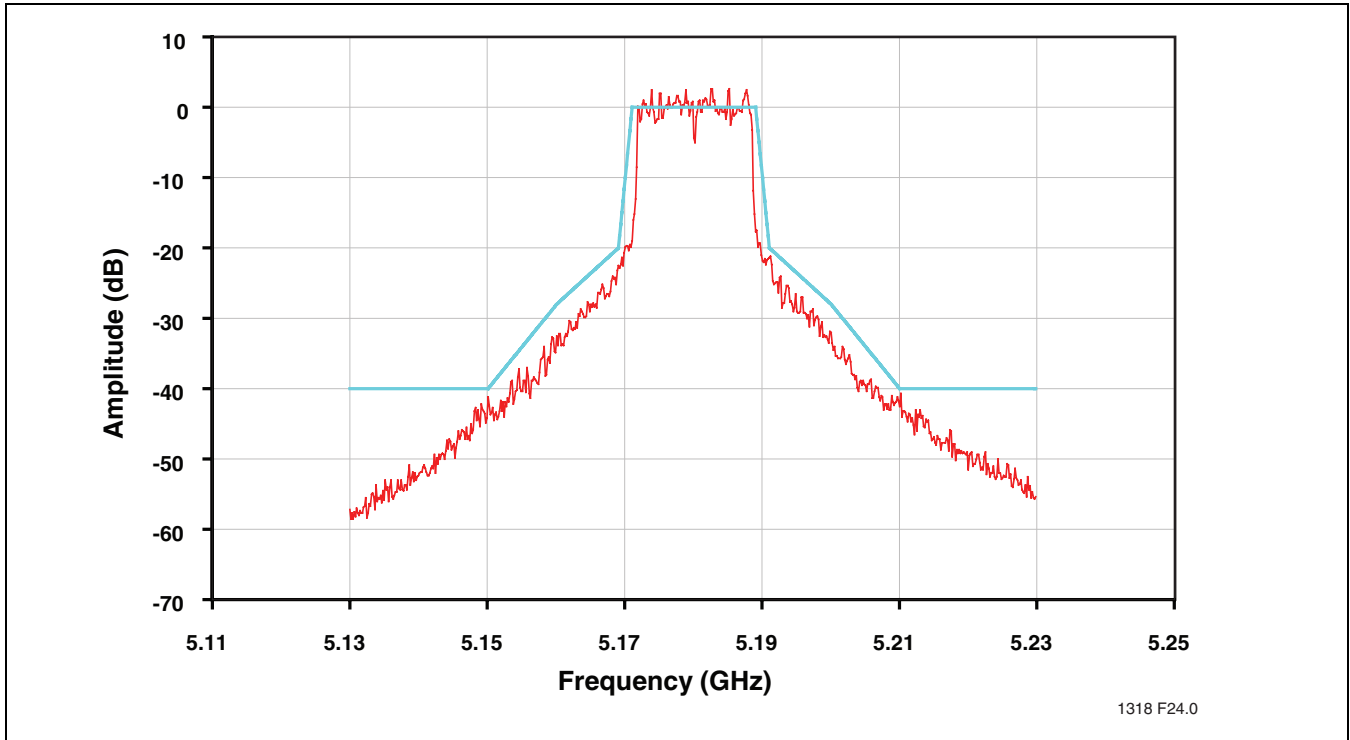

FIGURE 19: High Band 802.11a Spectrum Mask at 5.18 GHz at Output Power 22.5 dBm with DC Current at 355 mA

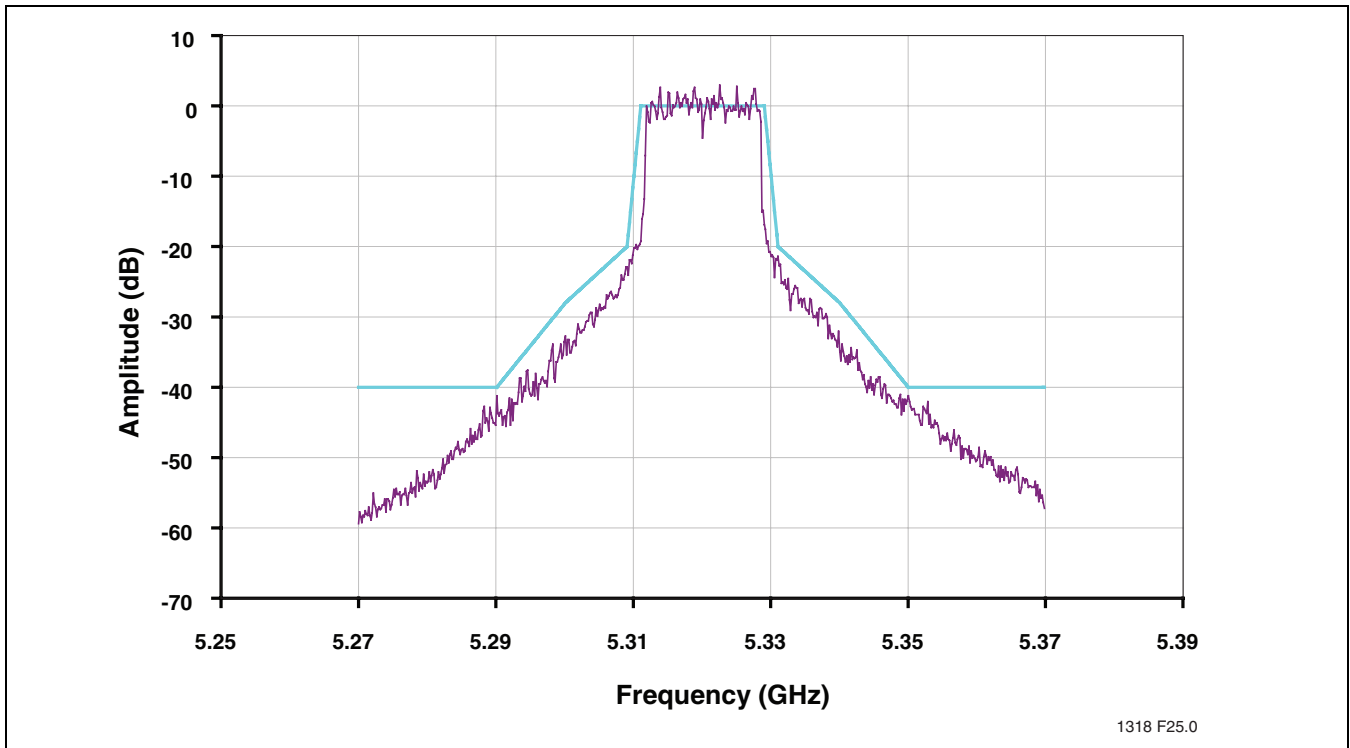

FIGURE 20: High Band 802.11a Spectrum Mask at 5.32 GHz at Output Power 23 dBm with DC Current at 360 mA

2.4-2.5 GHz / 4.9-5.8 GHz Dual-Band Power Amplifier SST13LP05



Data Sheet

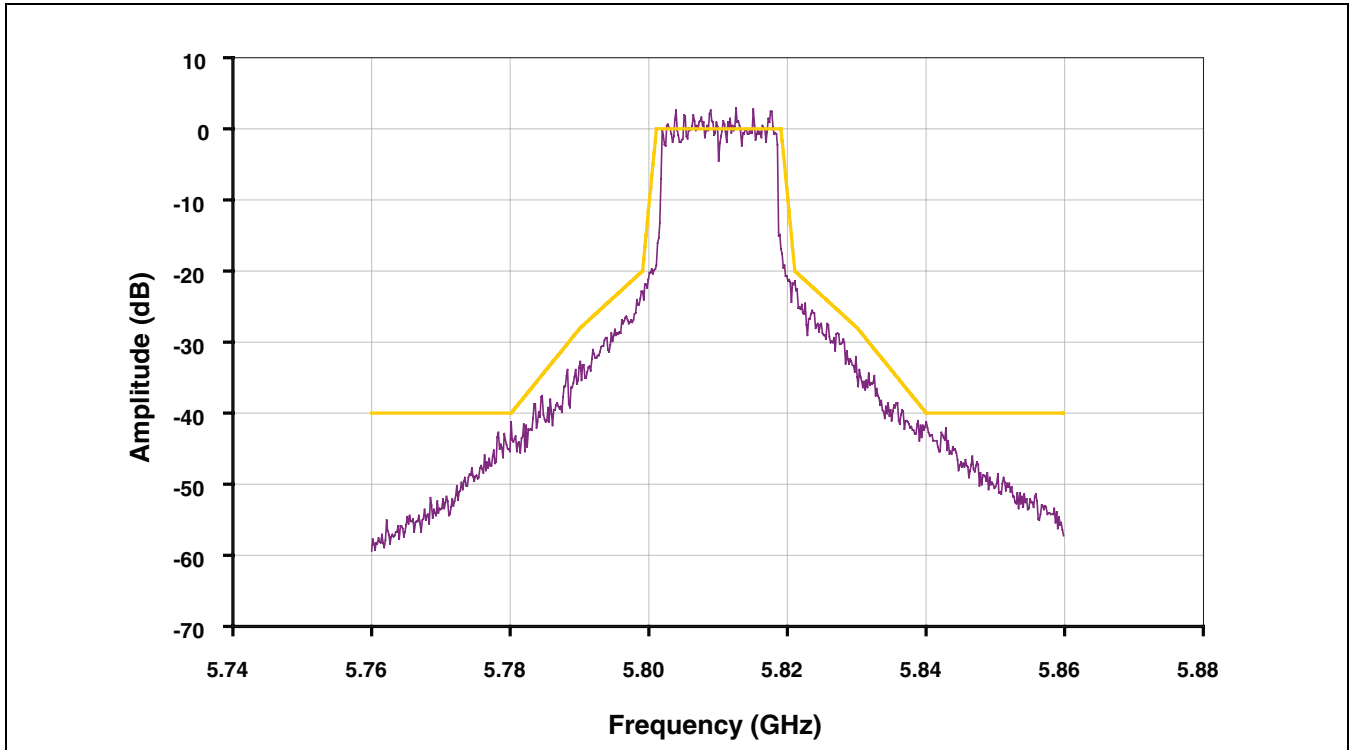

FIGURE 21: High Band 802.11a Spectrum Mask at 5.805 GHz at Output Power 23 dBm with DC Current at 350 mA



Data Sheet

High Band Power Detector characteristics

Test Conditions: $V_{CC} = 3.3V$, $V_{REF} = 2.95V$, $T_A = 25^\circ C$, 54 Mbps 802.11a OFDM Signal

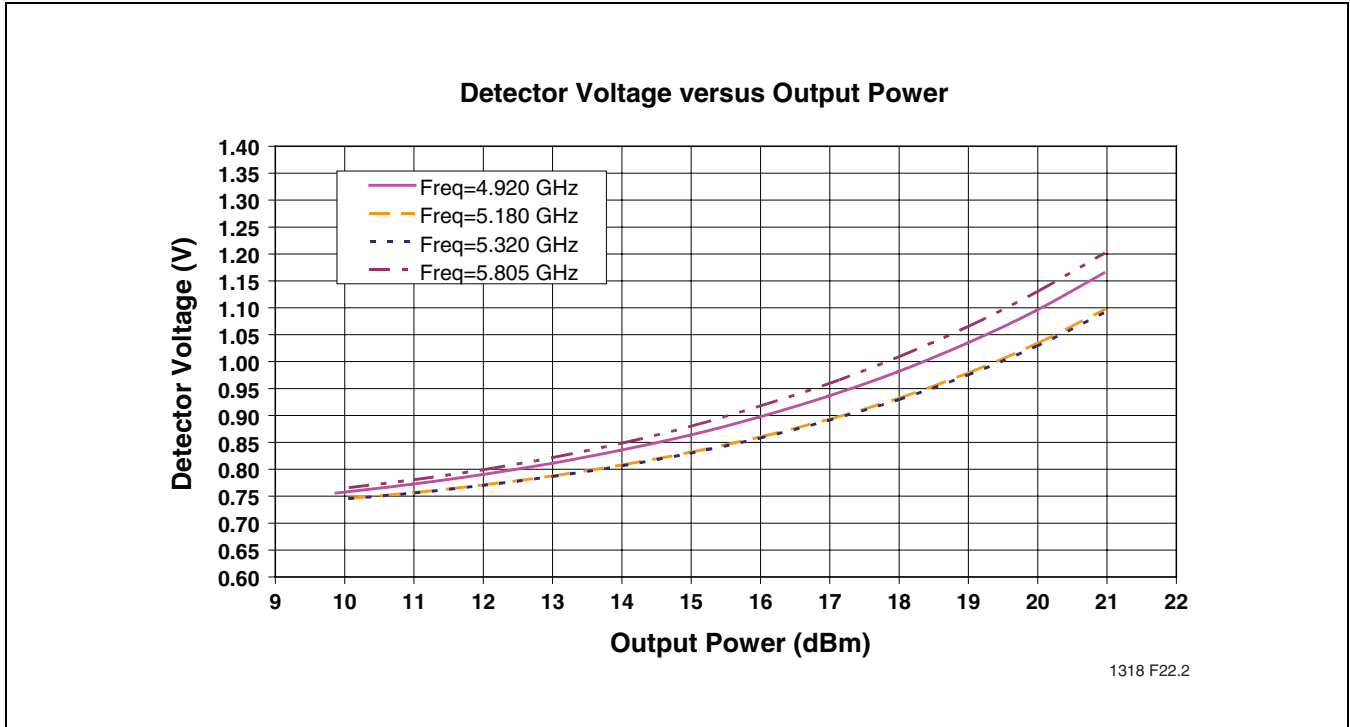

FIGURE 22: High Band Detector Voltage versus Output Power

2.4-2.5 GHz / 4.9-5.8 GHz Dual-Band Power Amplifier

SST13LP05



Data Sheet

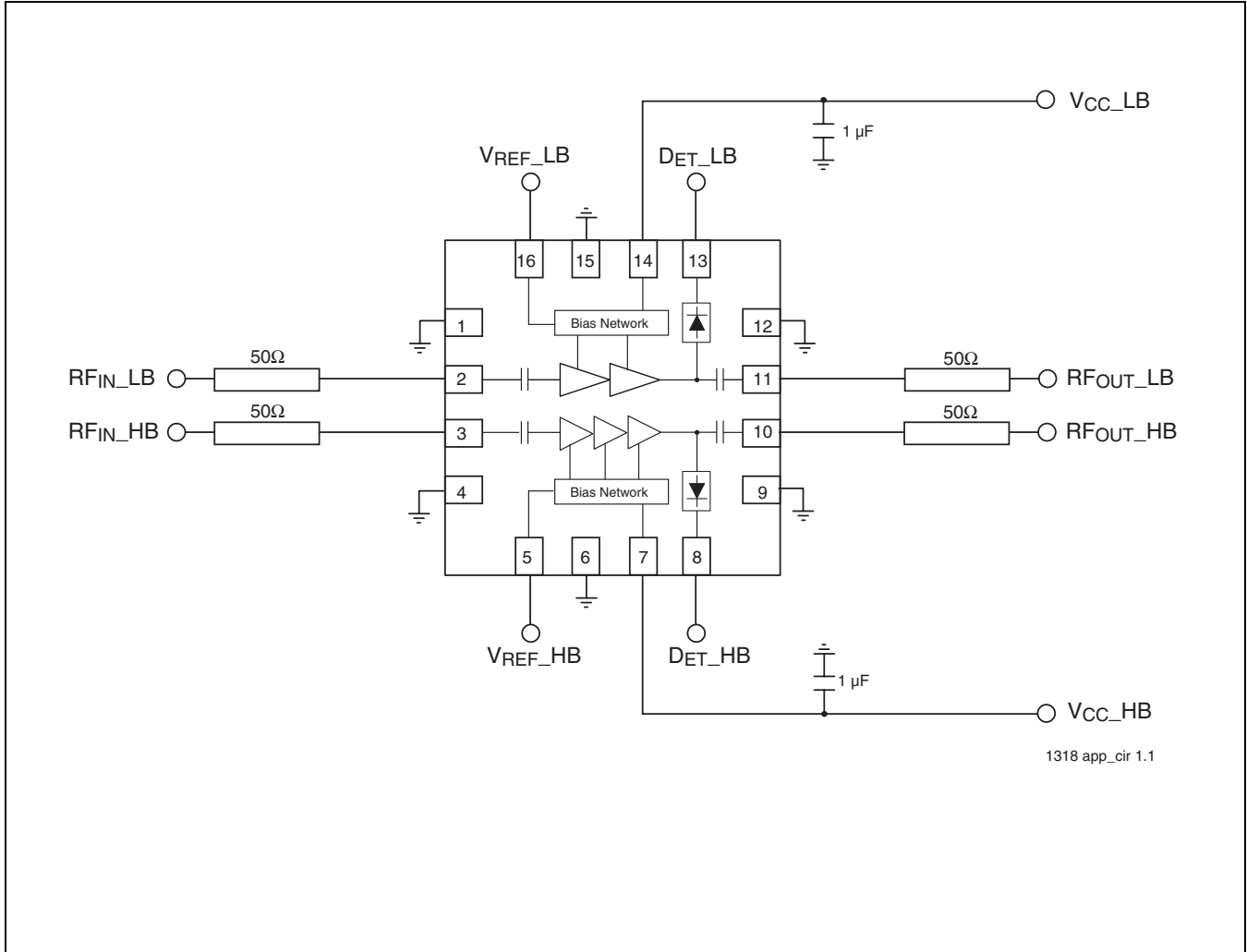
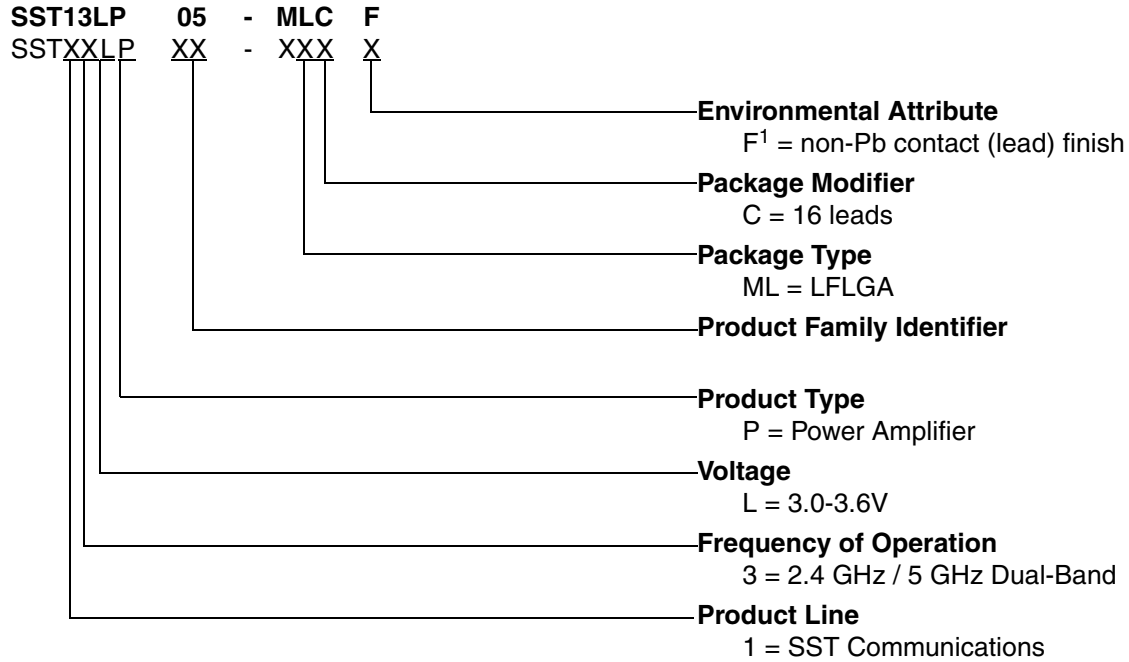

FIGURE 23: Typical Application Circuit



Data Sheet

PRODUCT ORDERING INFORMATION



1. Environmental suffix "F" denotes non-Pb solder.
 SST non-Pb solder devices are "RoHS Compliant".

Valid combinations for SST13LP05

SST13LP05-MLCF

SST13LP05 Evaluation Kits

SST13LP05-MLCF-K

Note: Consult your SST sales representative to confirm availability of valid combinations.



2.4-2.5 GHz / 4.9-5.8 GHz Dual-Band Power Amplifier

SST13LP05

Data Sheet

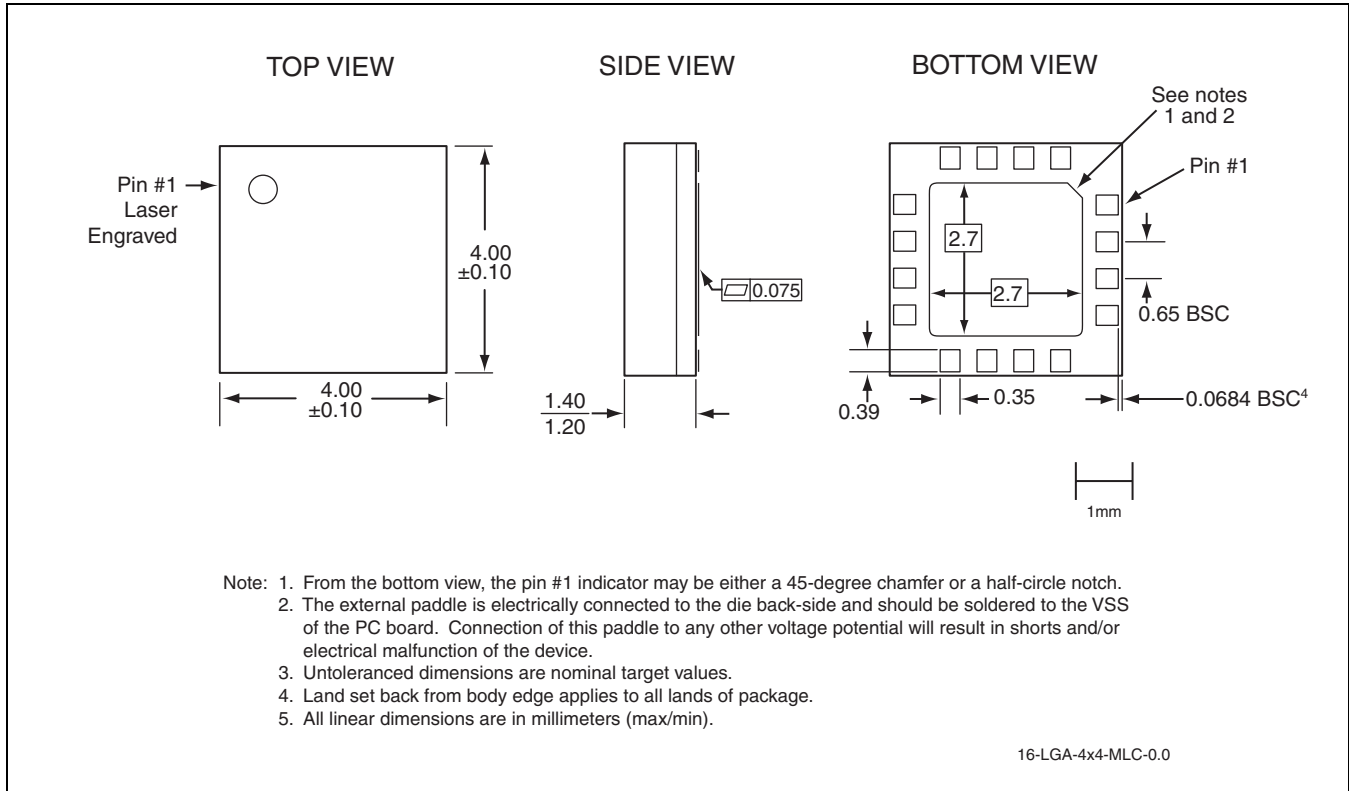

FIGURE 24: 16-Contact Low-profile, Fine-pitch, Land Grid Array (LFLGA)
SST Package Code: MLC

TABLE 6: Revision History

Revision	Description	Date
00	• Initial release of data sheet.	Dec 2006
01	• Updated document status from Preliminary Specification to Data Sheet	Apr 2008
02	• Updated "Contact Information" on page 24.	Feb 2009



Data Sheet

CONTACT INFORMATION

Marketing

SST Communications Corp.
5340 Alla Road, Ste. 210
Los Angeles, CA 90066
Tel: 310-577-3600
Fax: 310-577-3605

Sales and Marketing Offices

NORTH AMERICA

Silicon Storage Technology, Inc.
1171 Sonora Court
Sunnyvale, CA 94086-5308
Tel: 408-735-9110
Fax: 408-735-9036

EUROPE

Silicon Storage Technology Ltd.
Mark House
9-11 Queens Road
Hersham, Surrey
KT12 5LU UK
Tel: 44 (0) 1932-238133
Fax: 44 (0) 1932-230567

JAPAN

SST Japan
NOF Tameike Bldg, 9F
1-1-14 Akasaka, Minato-ku
Tokyo, Japan 107-0052
Tel: 81-3-5575-5515
Fax: 81-3-5575-5516

ASIA PACIFIC NORTH

SST Macao
Room N, 6th Floor,
Macao Finance Center, No. 202A-246,
Rua de Pequim, Macau
Tel: 853-2870-6022
Fax: 853-2870-6023

ASIA PACIFIC SOUTH

SST Communications Co.
16F-6, No. 75, Sec.1, Sintai 5th Rd
Sijhih City, Taipei County 22101
Taiwan, R.O.C.
Tel: 886-2-8698-1198
Fax: 886-2-8698-1190

KOREA

SST Korea
6F, Heungkuk Life Insurance Bldg 6-7
Sunae-Dong, Bundang-Gu, Sungnam-Si
Kyungki-Do, Korea, 463-020
Tel: 82-31-715-9138
Fax: 82-31-715-9137