

## UFX6000

# USB 2.0 Hi-Speed Graphics Controller with VGA, HDMI/DVI, and Digital RGB Interfaces



## PRODUCT FEATURES

Datasheet

### Highlights

- Single-Chip Hi-Speed USB 2.0 Graphics Adapter
- USB 2.0 Device Controller with Integrated USB 2.0 PHY
- Highly Efficient Compression Algorithm
- HDMI/DVI Display Connectivity via Integrated HDMI/DVI Controller/PHY
- VGA Display Connectivity via Integrated Video DAC
- Support for External Display Interface IC's via Digital RGB Interface
- High Performance DDR2 SDRAM Controller with Integrated DDR2 PHY

### Target Applications

- USB to Video Adapters
- Docking Stations, USB Port Replicators
- Thin Clients
- USB Monitors and Projectors
- Embedded Systems

### Features

- USB 2.0 Device Controller
  - Fully compliant with Universal Serial Bus Specification Revision 2.0
  - Operates in HS (480 Mbps) mode
  - Supports Control, Bulk-Out, and Interrupt-In endpoints
  - Supports vendor specific commands
  - Integrated USB 2.0 PHY
  - Integrated USB termination pull-up/pull-down resistors
  - Short circuit protection of USB differential signals

- Graphics Subsystem
  - Integrated HDMI/DVI Controller and PHY
    - Complies with DVI specification v1.0
    - Complies with HDMI specification v1.3
    - S/PDIF and I<sup>2</sup>S inputs for HDMI audio (2-channel uncompressed PCM)
    - Master I<sup>2</sup>C interface for DDC connection
  - Integrated Triple 10-bit Video DAC with VGA output
  - Digital RGB Interface
    - 12/15-bit double data rate digital RGB
    - 24-bit single data rate digital RGB
  - Supports up to 2048x1152 (QWXGA) with 32-bit color
  - 8-bit and 16-bit color support
  - Supports display cloning and extending
  - Standard and wide screen aspect ratios
  - Complies with VESA auto display identification
  - Gamma correction
  - Color Look-Up Table (CLUT)
  - Triple-buffered animations
  - Graphics Engine
    - Optimized algorithms for static and dynamic content
    - I<sup>2</sup>C controller
- DDR2 SDRAM Controller
  - 16-bit data bus, 13-bit address bus
  - JEDEC DDR2 compliant (JESD79-2E)
  - Integrated DDR2 SDRAM PHY
- Power
  - Reduced power operating modes
  - Supports bus-powered and self-powered operation
- Miscellaneous Features
  - Optional EEPROM controller
  - IEEE 1149.1 (JTAG) boundary scan TAP controller
- Software
  - Microsoft Windows<sup>®</sup> XP/Vista/7 drivers
- Packaging & Environmental
  - 225-ball LFBGA, lead-free RoHS compliant package
  - Commercial temperature range (0°C to +70°C)

**Order Number:**

**UFX6000-VE for 225-Ball LFBGA Lead-free RoHS Compliant Package (0 TO +70°C Temp Range)**

**This product meets the halogen maximum concentration values per IEC61249-2-21**

**For RoHS compliance and environmental information, please visit [www.smisc.com/rohs](http://www.smisc.com/rohs)**

**Please contact your SMSC sales representative for additional documentation related to this product such as application notes, anomaly sheets, and design guidelines.**

Copyright © 2012 SMSC or its subsidiaries. All rights reserved.

Circuit diagrams and other information relating to SMSC products are included as a means of illustrating typical applications. Consequently, complete information sufficient for construction purposes is not necessarily given. Although the information has been checked and is believed to be accurate, no responsibility is assumed for inaccuracies. SMSC reserves the right to make changes to specifications and product descriptions at any time without notice. Contact your local SMSC sales office to obtain the latest specifications before placing your product order. The provision of this information does not convey to the purchaser of the described semiconductor devices any licenses under any patent rights or other intellectual property rights of SMSC or others. All sales are expressly conditional on your agreement to the terms and conditions of the most recently dated version of SMSC's standard Terms of Sale Agreement dated before the date of your order (the "Terms of Sale Agreement"). The product may contain design defects or errors known as anomalies which may cause the product's functions to deviate from published specifications. Anomaly sheets are available upon request. SMSC products are not designed, intended, authorized or warranted for use in any life support or other application where product failure could cause or contribute to personal injury or severe property damage. Any and all such uses without prior written approval of an Officer of SMSC and further testing and/or modification will be fully at the risk of the customer. Copies of this document or other SMSC literature, as well as the Terms of Sale Agreement, may be obtained by visiting SMSC's website at <http://www.smisc.com>. SMSC is a registered trademark of Standard Microsystems Corporation ("SMSC"). Product names and company names are the trademarks of their respective holders.

The Microchip name and logo, and the Microchip logo are registered trademarks of Microchip Technology Incorporated in the U.S.A. and other countries.

**SMSC DISCLAIMS AND EXCLUDES ANY AND ALL WARRANTIES, INCLUDING WITHOUT LIMITATION ANY AND ALL IMPLIED WARRANTIES OF MERCHANTABILITY, FITNESS FOR A PARTICULAR PURPOSE, TITLE, AND AGAINST INFRINGEMENT AND THE LIKE, AND ANY AND ALL WARRANTIES ARISING FROM ANY COURSE OF DEALING OR USAGE OF TRADE. IN NO EVENT SHALL SMSC BE LIABLE FOR ANY DIRECT, INCIDENTAL, INDIRECT, SPECIAL, PUNITIVE, OR CONSEQUENTIAL DAMAGES; OR FOR LOST DATA, PROFITS, SAVINGS OR REVENUES OF ANY KIND; REGARDLESS OF THE FORM OF ACTION, WHETHER BASED ON CONTRACT; TORT; NEGLIGENCE OF SMSC OR OTHERS; STRICT LIABILITY; BREACH OF WARRANTY; OR OTHERWISE; WHETHER OR NOT ANY REMEDY OF BUYER IS HELD TO HAVE FAILED OF ITS ESSENTIAL PURPOSE, AND WHETHER OR NOT SMSC HAS BEEN ADVISED OF THE POSSIBILITY OF SUCH DAMAGES.**

## Table of Contents

<b>Chapter 1 Introduction</b> .....	<b>6</b>
1.1 USB Device Controller .....	6
1.2 Graphics Subsystem .....	7
1.3 DDR2 SDRAM Interface .....	7
1.4 Peripherals .....	7
<b>Chapter 2 Pin Description and Configuration</b> .....	<b>8</b>
2.1 Pin Assignments .....	25
2.2 Buffer Types .....	28
<b>Chapter 3 Power Connections</b> .....	<b>29</b>
<b>Chapter 4 EEPROM</b> .....	<b>30</b>
4.1 EEPROM Format .....	30
4.2 EEPROM Defaults .....	35
4.3 EEPROM Auto-Load .....	35
4.4 Customized Operation Without EEPROM .....	35
<b>Chapter 5 Operational Characteristics</b> .....	<b>36</b>
5.1 Absolute Maximum Ratings* .....	36
5.2 Operating Conditions** .....	36
5.3 Package Thermal Specifications .....	37
5.4 Current Consumption .....	37
5.4.1 SUSPEND Power State .....	37
5.4.2 Operational .....	38
5.5 DC Specifications .....	39
5.6 AC Specifications .....	40
5.6.1 Power Sequence Timing .....	41
5.6.2 Power-On Reset Timing .....	42
5.6.3 Reset Timing .....	43
5.6.4 Video DAC Timing .....	43
5.6.5 Digital RGB Timing .....	44
5.6.6 EEPROM Timing .....	46
5.6.7 JTAG Timing .....	47
5.7 Clock Circuit .....	48
<b>Chapter 6 Package Outline</b> .....	<b>49</b>
6.1 225-LFBGA Package .....	49
<b>Chapter 7 Datasheet Revision History</b> .....	<b>51</b>

## List of Figures

Figure 1.1	Internal Block Diagram	6
Figure 2.1	Pin Assignments (TOP VIEW)	8
Figure 3.1	Power Connections	29
Figure 5.1	Power-On Timing	41
Figure 5.1	nRESET Power-On Timing	42
Figure 5.1	nRESET Timing	43
Figure 5.2	Digital RGB Timing - DDR Mode	44
Figure 5.3	Digital RGB Timing - SDR Mode	45
Figure 5.4	EEPROM Timing	46
Figure 5.5	JTAG Timing	47
Figure 6.1	225-LFBGA Package Definition	49
Figure 6.2	225-LFBGA Package Ball Detail	49
Figure 6.1	225-LFBGA Recommended PCB Land Pattern	50

## List Of Tables

Table 2.1	USB Pins	9
Table 2.2	Digital RGB Pins	9
Table 2.3	RGB / DDR Mode Mapping Table	16
Table 2.4	VDAC Pins	17
Table 2.5	DDR2 Memory Pins	18
Table 2.6	HDMI Pins	19
Table 2.7	EEPROM Pins	20
Table 2.8	JTAG Pins	21
Table 2.9	Miscellaneous Pins	21
Table 2.10	I/O Power Pins, Core Power Pins, and Ground Pins	23
Table 2.11	No-Connect Pins	24
Table 2.12	225-LFBGA Package Pin Assignments	25
Table 2.13	Buffer Types	28
Table 4.1	EEPROM Format	31
Table 4.2	Configuration Flags 0	33
Table 4.3	EEPROM Defaults	35
Table 5.1	Package Thermal Parameters	37
Table 5.2	SUSPEND Supply Current	37
Table 5.3	Typical High-Speed Operational Supply Current (mA)	38
Table 5.4	I/O Buffer Characteristics	39
Table 5.5	Video DAC - DC Characteristics	40
Table 5.6	Power-On Timing Values	41
Table 5.7	nRESET Power-On Timing Values	42
Table 5.8	nRESET Timing Values	43
Table 5.9	Video DAC - AC Characteristics	43
Table 5.10	Digital RGB Timing Values - DDR Mode	44
Table 5.11	Digital RGB Timing Values - SDR Mode	45
Table 5.12	EEPROM Timing Values	46
Table 5.13	JTAG Timing Values	47
Table 5.14	Crystal Specifications	48
Table 6.1	225-LFBGA Package Parameters	50
Table 7.1	Customer Revision History	51

## Chapter 1 Introduction

The UFX6000 is a high performance USB 2.0 graphics adapter with multiple graphics interfaces. The UFX6000 is an ideal solution for extending a PC workspace to an additional monitor without the need for an additional internal graphics card. With applications ranging from docking stations, USB port replicators, USB monitors/projectors, and embedded systems, the UFX6000 is targeted as a high performance, low cost USB-to-graphics solution.

The UFX6000 contains an integrated USB 2.0 Device Controller, USB 2.0 PHY, USB Bulk-Out Controller, Control Endpoint, Interrupt-In Endpoint, DDR2 SDRAM Controller/PHY, Graphics Engine, HDMI/DVI Controller/PHY, Video DAC, TAP Controller, EEPROM Controller, and I<sup>2</sup>C Controller. Figure 1.1 details an internal block diagram of the UFX6000.

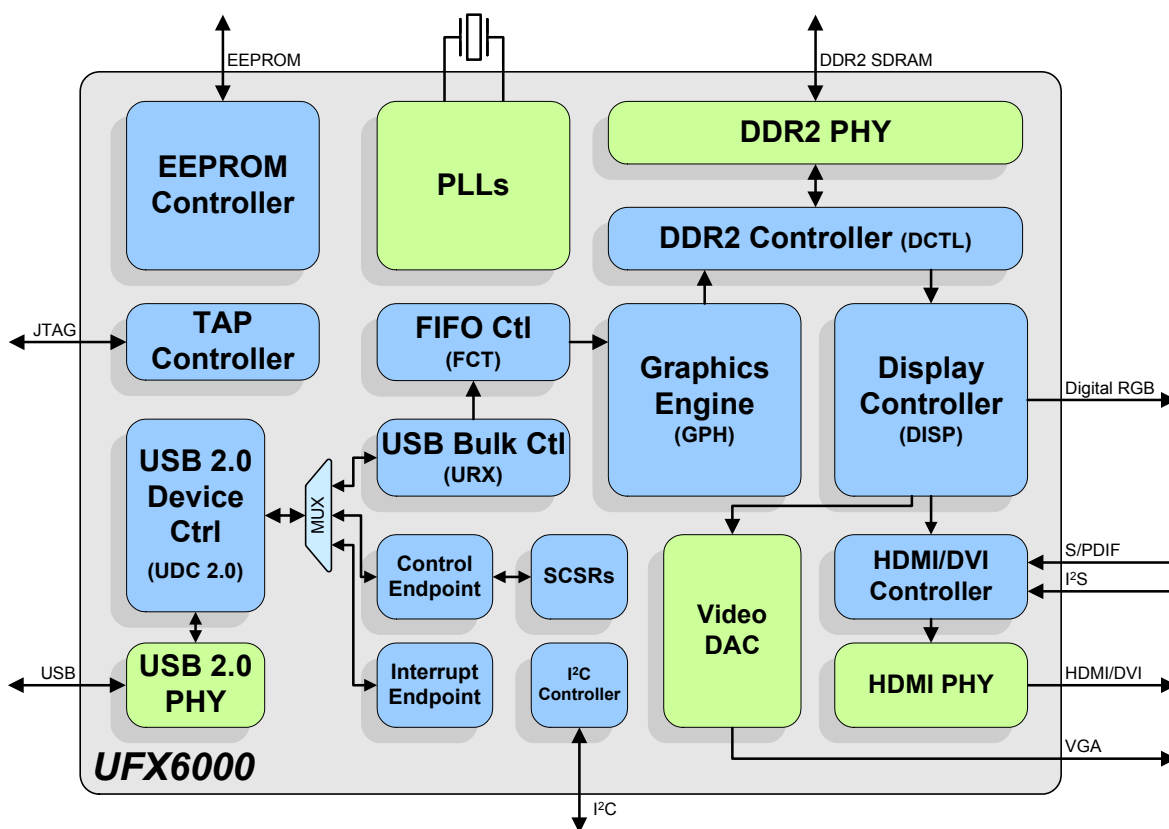

Figure 1.1 Internal Block Diagram

### 1.1 USB Device Controller

The USB Device Controller is fully compliant with the USB 2.0 Specification, enabling the device to operate in Hi-Speed (480 Mbps) mode. An integrated USB 2.0 PHY is provided on the USB port.

The controller implements three USB endpoints: Control, Bulk-Out, and Interrupt-In. The Bulk-Out endpoint allows for uncompressed or compressed graphics data reception from the USB port. The USB Bulk-Out Controller collects the graphics information and transfers it to the Graphics Engine. Implementation of vendor-specific commands allows for access to the device System Control and Status Registers (SCSRs).

## 1.2 Graphics Subsystem

The Graphics Subsystem consists of the following main blocks: the Graphics Engine, Display Controller, HDMI/DVI Controller/PHY, Video DAC, and the Digital RGB Interface. Together, these blocks support high definition resolutions of up to 2048x1152 (QWXGA) with 32-bit true color in both standard and wide screen aspect ratios. The HDMI/DVI interface is compliant with the HDMI v1.3 and DVI v1.0 specifications and supports 2-channel uncompressed PCM audio via a S/PDIF or I<sup>2</sup>S input. The Display Controller also supports 8-bit and 16-bit color, gamma correction, Color Look-Up Table (CLUT) and triple-buffered animations. The DDC2B/EDID VESA standard is supported, allowing the host OS and device drivers to query the monitor's frequency, resolution, and other features for true plug-and-play and intelligent mode setting capabilities.

Once the graphics data has been received via the USB Bulk-Out Controller, it is sent to the Graphics Engine. If the data is compressed, the Graphics Engine decompresses it via algorithms that have been optimized for speed and quality. The device's decompression algorithms have been designed to work seamlessly with the compression algorithms utilized in the software device drivers.

The graphics data is then transferred to the SDRAM via the DDR2 SDRAM Controller. The Display Controller generates all display and interface timing signals, retrieves the graphics data from the DDR2 SDRAM, and sends it to the HDMI/DVI Controller/PHY, Video DAC, or Digital RGB Interface.

The Digital RGB Interface may be used to connect external display interface IC's (e.g., DisplayPort, etc.) via the provided RGB data channel busses and control signals. The Digital RGB Interface supports two modes of operation: 24-bit single data rate mode and 12/15-bit double data rate mode. 24-bit mode is single edge triggered and utilizes the full 24-bit data bus width. The 12/15-bit mode is triggered on both clock edges and utilizes 12/15-bits of the data bus width.

## 1.3 DDR2 SDRAM Interface

The UFX6000 provides a full JEDEC compliant (JESD79-2E) DDR2 SDRAM Controller and PHY for interfacing to external DDR2 SDRAM. The DDR2 SDRAM interface is comprised of JEDEC standard 1.8V I/O signals grouped into control signals, a 16-bit data bus, and a 13-bit address bus.

The DDR2 SDRAM Controller transfers the graphics data in and out of external SDRAM through the DDR2 SDRAM PHY. External SDRAM is used as storage for the graphics and acts as a buffer between the Graphics Engine and Display Controller.

## 1.4 Peripherals

The UFX6000 also contains an EEPROM Controller, I<sup>2</sup>C Controller, and TAP Controller.

The EEPROM Controller allows connection to an external EEPROM for automatic loading of static configuration data upon power-on, pin reset, or software reset. The EEPROM can be configured to load USB descriptors and USB device configuration.

The integrated IEEE 1149.1 compliant TAP controller provides boundary scan via JTAG.

# Chapter 2 Pin Description and Configuration

## SMSC UF6000 225-LFBGA TOP VIEW

	1	2	3	4	5	6	7	8	9	10	11	12	13	14	15		
A	• DDRFOWE_IN	• DDRFOWE_OUT	• DDRQ07	• nDDRQ0S0	• DDRD0M0	• DDRQ01	• nDDRWE	• DDRA10	• DDRA3	• DDRA9	• DDRCK	• nDDRCAS	• DDRA2	• DDRA4	• DDRA8	A	
B	• DDRVREF0	• DDRQ05	• DDRQ00	• DDRQ0S9	• DDRQ06	• DDRQ03	• DDRCKE	• DDRBA0	• DDRA7	• DDRA12	• nDDRCK	• nDDRC	• DDRA6	• DDRA11	• VSS	B	
C	• DDRQ09	• DDRQ11	• DDRQ12	• DDRQ02	• VDD18DDR	• DDRQ04	• DDRBA1	• DDRA1	• DDRA5	• nDDRRAS	• VDD18DDR	• DDRA0	• DDRODT	• VSS	• EXTSWING	C	
D	• DDRQ0S1	• DDRD0M1	• DDRQ14	• VDD18DDR	• VDD18DDR	• DDRVREF2	• VDD18DDR	• VDD18DDR	• VDD18DDR	• VDD18DDR	• VDD18DDR	• VDD18DDR	• VDD18DDR	• VDD18DDR	• TX2P	• TX2N	D
E	• nDDRQ0S1	• DDRQ08	• DDRQ15	• VDD18DDR	• VDD18DDR	• VDD12CORE	• VSS	• VDD12CORE	• VSS	• VDD12CORE	• VDD18DDR	• VSSHDMI	• VDD12HDMI	• TX1P	• TX1N	E	
F	• DDRQ13	• DDRQ10	• DDRVREF1	• VDD18DDR	• VDD12CORE	• VSS	• VSS	• VSS	• VSS	• VSS	• VDD12CORE	• VSSHDMI	• VDD12HDMI	• TX0P	• TX0N	F	
G	• VSS	• VSS	• TEST1	• VSS	• VSS	• VSS	• VSS	• VSS	• VSS	• VSS	• VDD12CORE	• VSSHDMI	• VDD12HDMI	• TXCP	• TXCN	G	
H	• NC	• NC	• TEST2	• TEST3	• VDD12CORE	• VSS	• VSS	• VSS	• VSS	• VSS	• VSS	• VSSVDAC	• IREF	• VSSVDAC	• VDACR	• nVDACR	H
J	• NC	• NC	• VSS	• NC	• VSS	• VSS	• VSS	• VSS	• VSS	• VSS	• VSS	• VDD33VDAC	• VDD33VDAC	• VDD33VDAC	• VDACG	• nVDACG	J
K	• I2CSDA1/ GPIO27	• I2CSDA0	• I2CSCL1/ GPIO28	• I2CSCL0	• VDD12CORE	• VSS	• VSS	• VSS	• VSS	• VSS	• VSS	• VDACREF	• VDAC_HSYNC	• VDAC_VSYNC	• VDACB	• nVDACB	K
L	• USBDP	• USBDM	• VBUS_DET	• AUDIO_DIS/ GPIO30	• VDD33IO	• VDD12CORE	• VSS	• VDD12CORE	• VSS	• VDD12CORE	• VDD33IO	• VDD33IO	• VDD33IO	• WS/GPIO29	• MCLK/ GPIO25	• SPDIF/ I2SDATA/ GPIO26	L
M	• VDD33USB	• NC	• HPD	• VDATAB4/ VD3/GPIO20	• VDD33IO	• VDD33IO	• VDD33IO	• VDATAG4/ VD9/GPIO12	• VDD33IO	• VDATAR5/ GPIO5	• VDD33IO	• TDI	• INT	• EECS	• EECLK	M	
N	• XI	• VDD12USBPLL	• USBRBIAS	• VDATAB3/ VD4/GPIO19	• VDATAB0/ GPIO16	• nBLANK	• VDATAG7/ GPIO15	• VDATAG3/ GPIO11	• VDATAG0/ VD11/GPIO8	• VDATAR4/ VD13/GPIO4	• VDATAR1/ GPIO1	• TDO	• nEXTRST	• NC	• NC	N	
P	• XO	• SYSPLLG	• VDATAB6/ VD1/GPIO22	• VDATAB2/ VD5/GPIO18	• HSYNC	• nVCLK	• VDATAG6/ VD7/GPIO14	• VDATAG2/ GPIO10	• VDATAR7/ VD12/GPIO7	• VDATAR3/ VD14/GPIO3	• VDATAR0/ I2SCLKALT0/ GPIO0	• TCK	• nSW_MODE	• nRESET	• EEDI	P	
R	• SYSPLLP	• VDATAB7/ VD0/GPIO23	• VDATAB5/ VD2/GPIO21	• VDATAB1/ VD6/GPIO17	• VSYNC	• VCLK	• VDATAG5/ VD8/GPIO13	• VDATAG1/ VD10/GPIO9	• VDATAR6/ GPIO6	• VDATAR2/ VD15/GPIO2	• nTRST	• TMS	• NC	• LED/ I2SCLKALT1/ GPIO24	• EEDO	R	

Figure 2.1 Pin Assignments (TOP VIEW)



Table 2.1 USB Pins

NUM PINS	NAME	SYMBOL	BUFFER TYPE	DESCRIPTION
1	USB DMINUS	USBDM	AIO	USB Data Minus. <b>Note:</b> The functionality of this pin may be swapped to USB DPLUS via the <a href="#">Port Swap</a> bit of <a href="#">Configuration Flags 0</a> of the EEPROM.
1	USB DPLUS	USBDP	AIO	USB Data Plus. <b>Note:</b> The functionality of this pin may be swapped to USB DMINUS via the <a href="#">Port Swap</a> bit of <a href="#">Configuration Flags 0</a> of the EEPROM.
1	External USB Bias Resistor	USBRBIAS	AI	Used for setting HS transmit current level and on-chip termination impedance. Connect to an external 12K 1.0% resistor to ground.
1	Crystal Input	XI	ICLK	External 25 MHz crystal input. <b>Note:</b> This pin can also be driven by a single-ended clock oscillator. When this method is used, XO should be left unconnected.
1	Crystal Output	XO	OCLK	External 25 MHz crystal output.

Table 2.2 Digital RGB Pins

NUM PINS	NAME	SYMBOL	BUFFER TYPE	DESCRIPTION
1	Video Clock High	VCLK	RGB	Active high video clock.
1	Video Clock Low	nVCLK	RGB	Active low video clock.
1	Horizontal Sync	HSYNC	RGB	Video horizontal synchronization output.
1	Vertical Sync	VSYNC	RGB	Video vertical synchronization output.

**Table 2.2 Digital RGB Pins (continued)**

NUM PINS	NAME	SYMBOL	BUFFER TYPE	DESCRIPTION
1	Video Blanking	nBLANK	RGB	Active low video blanking signal.
1	Blue Pixel Data Channel Bit 7	VATAB7	RGB	Blue Pixel Video Data Bit 7, RGB Single Ended Mode.
	DDR RGB Data 0	VD0	RGB	Used in RGB DDR Mode, refer to <a href="#">Table 2.3</a> .
	General Purpose I/O 23	GPIO23	IS/O8/ OD8 (PU) <a href="#">Note 2.1</a>	This General Purpose I/O pin is fully programmable as either a push-pull output, an open-drain output, or a Schmitt-triggered input.
1	Blue Pixel Data Channel Bit 6	VATAB6	RGB	Blue Pixel Video Data Bit 6, RGB Single Ended Mode.
	DDR RGB Data 1	VD1	RGB	Used in RGB DDR Mode, refer to <a href="#">Table 2.3</a> .
	General Purpose I/O 22	GPIO22	IS/O8/ OD8 (PU) <a href="#">Note 2.1</a>	This General Purpose I/O pin is fully programmable as either a push-pull output, an open-drain output, or a Schmitt-triggered input.
1	Blue Pixel Data Channel Bit 5	VATAB5	RGB	Blue Pixel Video Data Bit 5, RGB Single Ended Mode.
	DDR RGB Data 2	VD2	RGB	Used in RGB DDR Mode, refer to <a href="#">Table 2.3</a> .
	General Purpose I/O 21	GPIO21	IS/O8/ OD8 (PU) <a href="#">Note 2.1</a>	This General Purpose I/O pin is fully programmable as either a push-pull output, an open-drain output, or a Schmitt-triggered input.
1	Blue Pixel Data Channel Bit 4	VATAB4	RGB	Blue Pixel Video Data Bit 4, RGB Single Ended Mode.
	DDR RGB Data 3	VD3	RGB	Used in RGB DDR Mode, refer to <a href="#">Table 2.3</a> .
	General Purpose I/O 20	GPIO20	IS/O8/ OD8 (PU) <a href="#">Note 2.1</a>	This General Purpose I/O pin is fully programmable as either a push-pull output, an open-drain output, or a Schmitt-triggered input.

Table 2.2 Digital RGB Pins (continued)

NUM PINS	NAME	SYMBOL	BUFFER TYPE	DESCRIPTION
1	Blue Pixel Data Channel Bit 3	VATAB3	RGB	Blue Pixel Video Data Bit 3, RGB Single Ended Mode.
	DDR RGB Data 4	VD4	RGB	Used in RGB DDR Mode, refer to <a href="#">Table 2.3</a> .
	General Purpose I/O 19	GPIO19	IS/O8/ OD8 (PU) <a href="#">Note 2.1</a>	This General Purpose I/O pin is fully programmable as either a push-pull output, an open-drain output, or a Schmitt-triggered input.
1	Blue Pixel Data Channel Bit 2	VATAB2	RGB	Blue Pixel Video Data Bit 2, RGB Single Ended Mode.
	DDR RGB Data 5	VD5	RGB	Used in RGB DDR Mode, refer to <a href="#">Table 2.3</a> .
	General Purpose I/O 18	GPIO18	IS/O8/ OD8 (PU) <a href="#">Note 2.1</a>	This General Purpose I/O pin is fully programmable as either a push-pull output, an open-drain output, or a Schmitt-triggered input.
1	Blue Pixel Data Channel Bit 1	VATAB1	RGB	Blue Pixel Video Data Bit 1, RGB Single Ended Mode.
	DDR RGB Data 6	VD6	RGB	Used in RGB DDR Mode, refer to <a href="#">Table 2.3</a> .
	General Purpose I/O 17	GPIO17	IS/O8/ OD8 (PU) <a href="#">Note 2.1</a>	This General Purpose I/O pin is fully programmable as either a push-pull output, an open-drain output, or a Schmitt-triggered input.
1	Blue Pixel Data Channel Bit 0	VATAB0	RGB	Blue Pixel Video Data Bit 0, RGB Single Ended Mode.
	General Purpose I/O 16	GPIO16	IS/O8/ OD8 (PU) <a href="#">Note 2.1</a>	This General Purpose I/O pin is fully programmable as either a push-pull output, an open-drain output, or a Schmitt-triggered input.
1	Green Pixel Data Channel Bit 7	VATAG7	RGB	Green Pixel Video Data Bit 7, RGB Single Ended Mode.
	General Purpose I/O 15	GPIO15	IS/O8/ OD8 (PU) <a href="#">Note 2.1</a>	This General Purpose I/O pin is fully programmable as either a push-pull output, an open-drain output, or a Schmitt-triggered input.

Table 2.2 Digital RGB Pins (continued)

NUM PINS	NAME	SYMBOL	BUFFER TYPE	DESCRIPTION
1	Green Pixel Data Channel Bit 6	VDATAG6	RGB	Green Pixel Video Data Bit 6, RGB Single Ended Mode.
	DDR RGB Data 7	VD7	RGB	Used in RGB DDR Mode, refer to <a href="#">Table 2.3</a> .
	General Purpose I/O 14	GPIO14	IS/O8/ OD8 (PU) <a href="#">Note 2.1</a>	This General Purpose I/O pin is fully programmable as either a push-pull output, an open-drain output, or a Schmitt-triggered input.
1	Green Pixel Data Channel Bit 5	VDATAG5	RGB	Green Pixel Video Data Bit 5, RGB Single Ended Mode.
	DDR RGB Data 8	VD8	RGB	Used in RGB DDR Mode, refer to <a href="#">Table 2.3</a> .
	General Purpose I/O 13	GPIO13	IS/O8/ OD8 (PU) <a href="#">Note 2.1</a>	This General Purpose I/O pin is fully programmable as either a push-pull output, an open-drain output, or a Schmitt-triggered input.
1	Green Pixel Data Channel Bit 4	VDATAG4	RGB	Green Pixel Video Data Bit 4, RGB Single Ended Mode.
	DDR RGB Data 9	VD9	RGB	Used in RGB DDR Mode, refer to <a href="#">Table 2.3</a> .
	General Purpose I/O 12	GPIO12	IS/O8/ OD8 (PU) <a href="#">Note 2.1</a>	This General Purpose I/O pin is fully programmable as either a push-pull output, an open-drain output, or a Schmitt-triggered input.
1	Green Pixel Data Channel Bit 3	VDATAG3	RGB	Green Pixel Video Data Bit 3, RGB Single Ended Mode.
	General Purpose I/O 11	GPIO11	IS/O8/ OD8 (PU) <a href="#">Note 2.1</a>	This General Purpose I/O pin is fully programmable as either a push-pull output, an open-drain output, or a Schmitt-triggered input.
1	Green Pixel Data Channel Bit 2	VDATAG2	RGB	Green Pixel Video Data Bit 2, RGB Single Ended Mode.
	General Purpose I/O 10	GPIO10	IS/O8/ OD8 (PU) <a href="#">Note 2.1</a>	This General Purpose I/O pin is fully programmable as either a push-pull output, an open-drain output, or a Schmitt-triggered input.

Table 2.2 Digital RGB Pins (continued)

NUM PINS	NAME	SYMBOL	BUFFER TYPE	DESCRIPTION
1	Green Pixel Data Channel Bit 1	VDATAG1	RGB	Green Pixel Video Data Bit 1, RGB Single Ended Mode.
	DDR RGB Data 10	VD10	RGB	Used in RGB DDR Mode, refer to <a href="#">Table 2.3</a> .
	General Purpose I/O 9	GPIO9	IS/O8/ OD8 (PU) <a href="#">Note 2.1</a>	This General Purpose I/O pin is fully programmable as either a push-pull output, an open-drain output, or a Schmitt-triggered input.
1	Green Pixel Data Channel Bit 0	VDATAG0	RGB	Green Pixel Video Data Bit 0, RGB Single Ended Mode.
	DDR RGB Data 11	VD11	RGB	Used in RGB DDR Mode, refer to <a href="#">Table 2.3</a> .
	General Purpose I/O 8	GPIO8	IS/O8/ OD8 (PU) <a href="#">Note 2.1</a>	This General Purpose I/O pin is fully programmable as either a push-pull output, an open-drain output, or a Schmitt-triggered input.
1	Red Pixel Data Channel Bit 7	VDATAR7	RGB	Red Pixel Video Data Bit 7, RGB Single Ended Mode.
	DDR RGB Data 12	VD12	RGB	Used in RGB DDR Mode, refer to <a href="#">Table 2.3</a> .
	General Purpose I/O 7	GPIO7	IS/O8/ OD8 (PU) <a href="#">Note 2.1</a>	This General Purpose I/O pin is fully programmable as either a push-pull output, an open-drain output, or a Schmitt-triggered input.
1	Red Pixel Data Channel Bit 6	VDATAR6	RGB	Red Pixel Video Data Bit 6, RGB Single Ended Mode.
	General Purpose I/O 6	GPIO6	IS/O8/ OD8 (PU) <a href="#">Note 2.1</a>	This General Purpose I/O pin is fully programmable as either a push-pull output, an open-drain output, or a Schmitt-triggered input.
1	Red Pixel Data Channel Bit 5	VDATAR5	RGB	Red Pixel Video Data Bit 5, RGB Single Ended Mode.
	General Purpose I/O 5	GPIO5	IS/O8/ OD8 (PU) <a href="#">Note 2.1</a>	This General Purpose I/O pin is fully programmable as either a push-pull output, an open-drain output, or a Schmitt-triggered input.

Table 2.2 Digital RGB Pins (continued)

NUM PINS	NAME	SYMBOL	BUFFER TYPE	DESCRIPTION
1	Red Pixel Data Channel Bit 4	VDATAR4	RGB	Red Pixel Video Data Bit 4, RGB Single Ended Mode.
	DDR RGB Data 13	VD13	RGB	Used in RGB DDR Mode, refer to <a href="#">Table 2.3</a> .
	General Purpose I/O4	GPIO4	IS/O8/ OD8 (PU) <a href="#">Note 2.1</a>	This General Purpose I/O pin is fully programmable as either a push-pull output, an open-drain output, or a Schmitt-triggered input.
1	Red Pixel Data Channel Bit 3	VDATAR3	RGB	Red Pixel Video Data Bit 3, RGB Single Ended Mode.
	DDR RGB Data 14	VD14	RGB	Used in RGB DDR Mode, refer to <a href="#">Table 2.3</a> .
	General Purpose I/O 3	GPIO3	IS/O8/ OD8 (PU) <a href="#">Note 2.1</a>	This General Purpose I/O pin is fully programmable as either a push-pull output, an open-drain output, or a Schmitt-triggered input.
1	Red Pixel Data Channel Bit 2	VDATAR2	RGB	Red Pixel Video Data Bit 2, RGB Single Ended Mode.
	DDR RGB Data 15	VD15	RGB	Used in RGB DDR Mode, refer to <a href="#">Table 2.3</a> .
	General Purpose I/O 2	GPIO2	IS/O8/ OD8 (PU) <a href="#">Note 2.1</a>	This General Purpose I/O pin is fully programmable as either a push-pull output, an open-drain output, or a Schmitt-triggered input.
1	Red Pixel Data Channel Bit 1	VDATAR1	RGB	Red Pixel Video Data Bit 1, RGB Single Ended Mode.
	General Purpose I/O 1	GPIO1	IS/O8/ OD8 (PU) <a href="#">Note 2.1</a>	This General Purpose I/O pin is fully programmable as either a push-pull output, an open-drain output, or a Schmitt-triggered input.

Table 2.2 Digital RGB Pins (continued)

NUM PINS	NAME	SYMBOL	BUFFER TYPE	DESCRIPTION
1	Red Pixel Data Channel Bit 0	VDATAR0	RGB	Red Pixel Video Data Bit 0, RGB Single Ended Mode.
	I <sup>2</sup> S Clock Alternate Input 0	I2SCLKALT0	IS	I <sup>2</sup> S Clock alternate input 0. The I <sup>2</sup> S clock input pin is selectable between the I2SCLKALT0 or I2SCLKALT1 pins. <b>Note:</b> If the single data rate RGB interface is enabled, I2SCLKALT1 should be used. I2SCLKALT0 should be used in all other cases.
	General Purpose I/O 0	GPIO0	IS/O8/OD8 (PU) <a href="#">Note 2.1</a>	This General Purpose I/O pin is fully programmable as either a push-pull output, an open-drain output, or a Schmitt-triggered input.

**Note 2.1** The internal pull-up is disabled when the GPIO is configured as an O8 buffer type.

**Table 2.3 RGB / DDR Mode Mapping Table**

SDR (24-BIT MODE)	DDR NAME	DDR (12-BIT MODE)		DDR (15-BIT MODE)	
		VCLK RISING EDGE	VCLK FALLING EDGE	VCLK RISING EDGE	VCLK FALLING EDGE
VCLK					
nVCLK					
HSYNC					
VSYNC					
nBLANK					
VATAB7	VD0	-	-	BLUE0	GREEN5
VATAB6	VD1	-	-	BLUE1	GREEN6
VATAB5	VD2	BLUE0	GREEN4	BLUE2	GREEN7
VATAB4	VD3	BLUE1	GREEN5	BLUE3	GREEN8
VATAB3	VD4	BLUE2	GREEN6	BLUE4	GREEN9
VATAB2	VD5	BLUE3	GREEN7	BLUE5	RED0
VATAB1	VD6	BLUE4	RED0	BLUE6	RED1
VATAB0	-	-	-	-	-
VATAG7	-	-	-	-	-
VATAG6	VD7	BLUE5	RED1	BLUE7	RED2
VATAG5	VD8	BLUE6	RED2	BLUE8	RED3
VATAG4	VD9	BLUE7	RED3	BLUE9	RED4
VATAG3	-	-	-	-	-
VATAG2	-	-	-	-	-
VATAG1	VD10	-	-	GREEN0	RED5
VATAG0	VD11	-	-	GREEN1	RED6
VATAR7	VD12	GREEN0	RED4	GREEN2	RED7
VATAR6	-	-	-	-	-
VATAR5	-	-	-	-	-
VATAR4	VD13	GREEN1	RED5	GREEN3	RED8
VATAR3	VD14	GREEN2	RED6	GREEN4	RED9
VATAR2	VD15	GREEN3	RED7	-	-
VATAR1	-	-	-	-	-
VATAR0	-	-	-	-	-



**Table 2.4 VDAC Pins**

<b>NUM PINS</b>	<b>NAME</b>	<b>SYMBOL</b>	<b>BUFFER TYPE</b>	<b>DESCRIPTION</b>
1	VDAC VSYNC	VDAC_VSYNC	RGB	VDAC vertical synchronization output.
1	VDAC HSYNC	VDAC_HSYNC	RGB	VDAC horizontal synchronization output.
1	Positive Red Analog Output	VDACR	AO	Positive Red VDAC analog output current.
1	Negative Red Analog Output	nVDACR	AO	Negative Red VDAC analog output current.
1	Positive Green Analog Output	VDACG	AO	Positive Green VDAC analog output current.
1	Negative Green Analog Output	nVDACG	AO	Negative Green VDAC analog output current.
1	Positive Blue Analog Output	VDACB	AO	Positive Blue VDAC analog output current.
1	Negative Blue Analog Output	nVDACB	AO	Negative Blue VDAC analog output current.
1	VDAC Reference Current	IREF	AI	VDAC reference current. Output current when using External Reference Resistor or Input Reference Current when using external current source.

Table 2.5 DDR2 Memory Pins

NUM PINS	NAME	SYMBOL	BUFFER TYPE	DESCRIPTION
13	DDR2 Memory Address Bus	DDRA[12:0]	DDR2O	Bits 12:0 of the external DDR2 memory address bus.
16	DDR2 Memory Data Bus	DDRQ[15:0]	DDR2I/ DDR2O	Bits 15:0 of the external DDR2 memory data bus.
2	DDR2 Memory Bank Address	DDRBA[1:0]	DDR2O	DDR2 memory bank address.
1	DDR2 Memory Clock High	DDRCK	DDR2O	Active high DDR2 clock. This clock is the complement of nDDRCK.
1	DDR2 Memory Clock Low	nDDRCK	DDR2O	Active low DDR2 clock. This clock is the complement of DDRCK.
1	DDR2 Memory Clock Enable Output	DDRCKE	DDR2O	DDR2 clock enable signal.
1	DDR2 Memory Chip Select	nDDRCSS	DDR2O	Active low chip select.
1	DDR2 Memory Row Address Strobe	nDDRRAS	DDR2O	Active low row address strobe.
1	DDR2 Memory Column Address Strobe	nDDRCAS	DDR2O	Active low column address strobe.
1	DDR2 Memory Write Enable	nDDRWE	DDR2O	Active low write enable.
1	DDR2 On Die Termination	DDRODT	DDR2O	DDR2 on die termination.
1	DDR2 Memory Lower Byte Mask	DDRDM0	DDR2O	Mask bit for lower byte of DDR2 data word.
1	DDR2 Memory Upper Byte Mask	DDRDM1	DDR2O	Mask bit for upper byte of DDR2 data word.

Table 2.5 DDR2 Memory Pins (continued)

NUM PINS	NAME	SYMBOL	BUFFER TYPE	DESCRIPTION
1	DDR2 Memory Lower Byte Strobe High	DDRDQS0	DDR2I/DDR2O	Active high data strobe for lower byte of DDR2 data word.
1	DDR2 Memory Lower Byte Strobe Low	nDDRDQS0	DDR2I/DDR2O	Active low data strobe for upper byte of DDR2 data word.
1	DDR2 Memory Upper Byte Strobe High	DDRDQS1	DDR2I/DDR2O	Active high data strobe for upper byte of DDR2 data word.
1	DDR2 Memory Upper Byte Strobe Low	nDDRDQS1	DDR2I/DDR2O	Active low data strobe for upper byte of DDR2 data word.
1	DDR2 Memory Reference Voltage 0	DDRVREF0	AI	Reference voltage input pin for DDR2 Memory. DDRVREF0 must be half the VDD18DDR voltage.
1	DDR2 Memory Reference Voltage 1	DDRVREF1	AI	Reference voltage input pin for DDR2 Memory. DDRVREF1 must be half the VDD18DDR voltage.
1	DDR2 Memory Reference Voltage 2	DDRVREF2	AI	Reference voltage input pin for DDR2 Memory. DDRVREF2 must be half the VDD18DDR voltage.
1	DQS Enable Timing Match Input	DDRFIFOWE_IN	DDR2I	DQS enable input for timing match between DQS and system clock.
1	DQS Enable Timing Match Output	DDRFIFOWE_OUT	DDR2O	DQS enable output for timing match between DQS and system clock.

Table 2.6 HDMI Pins

NUM PINS	NAME	SYMBOL	BUFFER TYPE	DESCRIPTION
1	TMDS Clock Positive	TXCP	AO	TMDS clock output differential positive signal.
1	TMDS Clock Negative	TXCN	AO	TMDS clock output differential negative signal.
1	TMDS Out0 Positive	TX0P	AO	TMDS Output 0 differential positive signal.

Table 2.6 HDMI Pins (continued)

NUM PINS	NAME	SYMBOL	BUFFER TYPE	DESCRIPTION
1	TMDS Out0 Negative	TX0N	AO	TMDS Output 0 differential negative signal.
1	TMDS Out1 Positive	TX1P	AO	TMDS Output 1 differential positive signal.
1	TMDS Out1 Negative	TX1N	AO	TMDS Output 1 differential negative signal.
1	TMDS Out2 Positive	TX2P	AO	TMDS Output 2 differential positive signal.
1	TMDS Out2 Negative	TX2N	AO	TMDS Output 2 differential negative signal.
1	Voltage Swing Adjust	EXTSWING	AI	Connect this pin to an external resistor going to ground. The resistor determines the amplitude of the voltage swing. A low capacitive connection is allowed. A value of 5K is recommended.
1	Hot Plug Detect	HPD	IS	Hot plug detect signal.

Table 2.7 EEPROM Pins

NUM PINS	NAME	SYMBOL	BUFFER TYPE	DESCRIPTION
1	EEPROM Data In	EEDI	IS (PD)	This pin is driven by the EEDO output of the external EEPROM.
1	EEPROM Data Out	EEDO	O8	This pin drives the EEDI input of the external EEPROM. <b>Note:</b> This pin is also used for internal production test purposes and should never be pulled high. If connected to a load, use of an external 4.7K pull-down resistor is recommended.
1	EEPROM Chip Select	EECS	O8	This pin drives the chip select output of the external EEPROM. <b>Note:</b> The EECS output may tri-state briefly during power-up. Some EEPROM devices may be prone to false selection during this time. When an EEPROM is used, an external pull-down resistor is recommended on this signal to prevent false selection. Refer to your EEPROM manufacturer's datasheet for additional information.
1	EEPROM Clock	EECLK	O8	This pin drives the EEPROM clock of the external EEPROM.

Table 2.8 JTAG Pins

NUM PINS	NAME	SYMBOL	BUFFER TYPE	DESCRIPTION
1	JTAG Test Data Out	TDO	O8	JTAG data output.
1	JTAG Test Clock	TCK	IS	JTAG test clock. The maximum operating frequency of this clock is 25MHz.
1	JTAG Test Mode Select	TMS	IS	JTAG test mode select.
1	JTAG Test Data Input	TDI	IS	JTAG data input.
1	JTAG Test Port Reset	nTRST	IS	JTAG test port reset input.

Table 2.9 Miscellaneous Pins

NUM PINS	NAME	SYMBOL	BUFFER TYPE	DESCRIPTION
	LED	LED	O8/ OD8 (PU)	Can be used to provide device status. Alternatively, the LED can be configured for a fast or slow blink in accordance with the USB graphics data receive rate.
1	I <sup>2</sup> S Clock Alternate Input 1	I2SCLKALT1	IS	I <sup>2</sup> S Clock alternate input 1. The I <sup>2</sup> S clock input pin is selectable between the <a href="#">I2SCLKALT0</a> or <a href="#">I2SCLKALT1</a> pins. <b>Note:</b> If the single data rate RGB interface is enabled, <a href="#">I2SCLKALT1</a> should be used. <a href="#">I2SCLKALT0</a> should be used in all other cases.
	General Purpose I/O 24	GPIO24	IS/O8/ OD8 (PU) <a href="#">Note 2.3</a>	This General Purpose I/O pin is fully programmable as either a push-pull output, an open-drain output, or a Schmitt-triggered input.
1	Interrupt	INT	IS	For use by external transmitter to signal an event requiring servicing.
1	External Reset Output	nEXTRST	O8	Used to reset the external transmitter. The polarity and period of the reset signal generated on this pin is programmable via internal registers.
1	Switching Regulator Mode	nSW_MODE	O8	When asserted, this pin can be used to place the external switching regulator into power saving mode. <b>Note:</b> The <a href="#">SW_MODE Polarity</a> bit of <a href="#">Configuration Flags 0</a> controls the polarity of the pin.

**Table 2.9 Miscellaneous Pins (continued)**

NUM PINS	NAME	SYMBOL	BUFFER TYPE	DESCRIPTION
1	System Reset Input	nRESET	IS	This active-low pin allows external hardware to reset the device. <b>Note:</b> Assertion of nRESET is required following power-on.
1	Detect Upstream VBUS Power	VBUS_DET	IS	Detects the state of the upstream bus power. For bus powered operation, this pin must be tied to VDD33IO. For self powered operation, refer to the device reference schematics. <b>Note:</b> The VBUS_DET signal is deglitched for a period of 10 ms.
1	I <sup>2</sup> C Data 0	I2CSDA0	IS/ OD8 <a href="#">Note 2.2</a>	Bi-directional I <sup>2</sup> C data 0 signal.
1	I <sup>2</sup> C Clock 0	I2CSCL0	IS/ OD8 <a href="#">Note 2.2</a>	Bi-directional I <sup>2</sup> C clock 0 signal. All I <sup>2</sup> C transactions are synchronous to the rising edge of this clock. The device supports the I <sup>2</sup> C standard mode of operation (100 Kb/s). As an I <sup>2</sup> C master, the device drives this clock.
1	I <sup>2</sup> C Data 1	I2CSDA1	IS/ OD8 <a href="#">Note 2.2</a>	Bi-directional I <sup>2</sup> C data 1 signal.
1	General Purpose I/O 27	GPIO27	IS/ O8/ OD8 (PU) <a href="#">Note 2.3</a>	This General Purpose I/O pin is fully programmable as either a push-pull output, an open-drain output, or a Schmitt-triggered input.
1	I <sup>2</sup> C Clock 1	I2CSCL1	IS/OD8 <a href="#">Note 2.2</a>	Bi-directional I <sup>2</sup> C clock 1 signal. All I <sup>2</sup> C transactions are synchronous to the rising edge of this clock. The device supports the I <sup>2</sup> C standard mode of operation (100 Kb/s). As an I <sup>2</sup> C master, the device drives this clock.
1	General Purpose I/O 28	GPIO28	IS/O8/ OD8 (PU) <a href="#">Note 2.3</a>	This General Purpose I/O pin is fully programmable as either a push-pull output, an open-drain output, or a Schmitt-triggered input.
1	Audio Input Master Clock	MCLK	IS	Audio input master clock. This clock is coherent with the S/PDIF audio input.
1	General Purpose I/O 25	GPIO25	IS/O8/ OD8 (PU) <a href="#">Note 2.3</a>	This General Purpose I/O pin is fully programmable as either a push-pull output, an open-drain output, or a Schmitt-triggered input.

Table 2.9 Miscellaneous Pins (continued)

NUM PINS	NAME	SYMBOL	BUFFER TYPE	DESCRIPTION
1	S/PDIF Audio Input	SPDIF	IS	Digital audio interface input. Supports PCM, Dolby Digital, and DTS Digital audio transmission. <b>Note:</b> Usage of SPDIF requires the MCLK audio input master clock pin.
	I <sup>2</sup> S Data	I2SDATA	IS	I <sup>2</sup> S Data input.
	General Purpose I/O 26	GPIO26	IS/O8/OD8 (PU) <a href="#">Note 2.3</a>	This General Purpose I/O pin is fully programmable as either a push-pull output, an open-drain output, or a Schmitt-triggered input.
1	Audio Word Select	WS	IS	Specifies the I <sup>2</sup> S word select input of the audio processor.
	General Purpose I/O 29	GPIO29	IS/O8/OD8 (PU) <a href="#">Note 2.3</a>	This General Purpose I/O pin is fully programmable as either a push-pull output, an open-drain output, or a Schmitt-triggered input.
1	Audio CODEC Disconnect	AUDIO_DIS	O8	This pin is used for disconnecting an external USB audio CODEC.  Refer to the UFX6000 reference schematic for additional details.
	General Purpose I/O 30	GPIO30	IS/O8/OD8 (PU) <a href="#">Note 2.3</a>	This General Purpose I/O pin is fully programmable as either a push-pull output, an open-drain output, or a Schmitt-triggered input.
1	Test 1	TEST1	-	This pin must always be connected to VSS.
1	Test 2	TEST2	-	This pin must always be connected to VSS.
1	Test 3	TEST3	-	This pin must always be connected to VSS.

**Note 2.2** If unused, this signal must be pulled to a valid state.

**Note 2.3** The internal pull-up is disabled when the GPIO is configured as an O8 buffer type.

Table 2.10 I/O Power Pins, Core Power Pins, and Ground Pins

NUM PINS	NAME	SYMBOL	BUFFER TYPE	DESCRIPTION
1	SYS PLL Filter Pin 1	SYSPLL1P	P	System and pixel PLL filter pin.  Refer to the UFX6000 reference schematic for additional details.
1	SYS PLL Filter Pin 2	SYSPLL2P	P	System and pixel PLL filter pin.  Refer to the UFX6000 reference schematic for additional details.
3	+1.2 V HDMI Power Input	VDD12HDMI	P	+1.2 V HDMI power input.

**Table 2.10 I/O Power Pins, Core Power Pins, and Ground Pins (continued)**

NUM PINS	NAME	SYMBOL	BUFFER TYPE	DESCRIPTION
3	HDMI Ground	VSSHDMI	P	HDMI ground.
3	+3.3 V VDAC Power Input	VDD33VDAC	P	+3.3 V Video DAC power input. (Note 2.4)
1	+3.3 V VDAC Reference Input	VDACREF	P	+3.3 V Video DAC reference voltage input. (Note 2.4)
2	VDAC Ground	VSSVDAC	P	Video DAC ground.
1	+3.3 V USB Power Input	VDD33USB	P	+3.3 V USB power input. (Note 2.4)
1	+1.2 V USB PLL Supply Input	VDD12USBPLL	P	+1.2 V USB PLL supply input. (Note 2.4)
15	+1.8 V DDR2 Power Input	VDD18DDR	P	+1.8 V DDR2 power input. (Note 2.4)
8	+3.3 V I/O Power Input	VDD33IO	P	+3.3 V I/O power input. (Note 2.4)
11	+1.2 V Digital Core Power Input	VDD12CORE	P	+1.2 V digital core power input. (Note 2.4)
37	Ground	VSS	P	Common Ground.

**Note 2.4** Refer to [Chapter 3, "Power Connections,"](#) on page 29 and the device reference schematics for additional power connection information.

**Table 2.11 No-Connect Pins**

NUM PINS	NAME	SYMBOL	BUFFER TYPE	DESCRIPTION
9	No Connect	NC	-	These pins must be left floating for normal device operation.



## 2.1 Pin Assignments

Table 2.12 225-LFBGA Package Pin Assignments

PIN NUM	PIN NAME	PIN NUM	PIN NAME	PIN NUM	PIN NAME	PIN NUM	PIN NAME
A1	DDRFIFOWE_IN	B1	DDRVREF0	C1	DDRQ9	D1	DDRQ1
A2	DDRFIFOWE_OUT	B2	DDRQ5	C2	DDRQ11	D2	DDRDM1
A3	DDRQ7	B3	DDRQ0	C3	DDRQ12	D3	DDRQ14
A4	nDDRQ0	B4	DDRQ0	C4	DDRQ2	D4	VDD18DDR
A5	DDRDM0	B5	DDRQ6	C5	VDD18DDR	D5	VDD18DDR
A6	DDRQ1	B6	DDRQ3	C6	DDRQ4	D6	DDRVREF2
A7	nDDRWE	B7	DDRCKE	C7	DDRBA1	D7	VDD18DDR
A8	DDRA10	B8	DDRBA0	C8	DDRA1	D8	VDD18DDR
A9	DDRA3	B9	DDRA7	C9	DDRA5	D9	VDD18DDR
A10	DDRA9	B10	DDRA12	C10	nDDRRAS	D10	VDD18DDR
A11	DDRCCK	B11	nDDRCK	C11	VDD18DDR	D11	VDD18DDR
A12	nDDRCAS	B12	nDDRCAS	C12	DDRA0	D12	VDD18DDR
A13	DDRA2	B13	DDRA6	C13	DDRODT	D13	VDD18DDR
A14	DDRA4	B14	DDRA11	C14	VSS	D14	TX2P
A15	DDRA8	B15	VSS	C15	EXTSWING	D15	TX2N
E1	nDDRQ0	F1	DDRQ13	G1	VSS	H1	NC
E2	DDRQ8	F2	DDRQ10	G2	VSS	H2	NC
E3	DDRQ15	F3	DDRVREF1	G3	TEST1	H3	TEST2
E4	VDD18DDR	F4	VDD18DDR	G4	VSS	H4	TEST3
E5	VDD18DDR	F5	VDD12CORE	G5	VSS	H5	VDD12CORE
E6	VDD12CORE	F6	VSS	G6	VSS	H6	VSS
E7	VSS	F7	VSS	G7	VSS	H7	VSS
E8	VDD12CORE	F8	VSS	G8	VSS	H8	VSS
E9	VSS	F9	VSS	G9	VSS	H9	VSS
E10	VDD12CORE	F10	VSS	G10	VSS	H10	VSS
E11	VDD18DDR	F11	VDD12CORE	G11	VDD12CORE	H11	VSSVDAC
E12	VSSHDMI	F12	VSSHDMI	G12	VSSHDMI	H12	IREF
E13	VDD12HDMI	F13	VDD12HDMI	G13	VDD12HDMI	H13	VSSVDAC
E14	TX1P	F14	TX0P	G14	TXCP	H14	VDACR
E15	TX1N	F15	TX0N	G15	TXCN	H15	nVDACR

**Table 2.12 225-LFBGA Package Pin Assignments (continued)**

PIN NUM	PIN NAME	PIN NUM	PIN NAME	PIN NUM	PIN NAME	PIN NUM	PIN NAME
J1	NC	K1	I2CSDA1/ GPIO27	L1	USBDP	M1	VDD33USB
J2	NC	K2	I2CSDA0	L2	USBDM	M2	NC
J3	VSS	K3	I2CSCL1/ GPIO28	L3	VBUS_DET	M3	HPD
J4	NC	K4	I2CSCL0	L4	AUDIO_DIS/ GPIO30	M4	VATAB4/VD3/ GPIO20
J5	VSS	K5	VDD12CORE	L5	VDD33IO	M5	VDD33IO
J6	VSS	K6	VSS	L6	VDD12CORE	M6	VDD33IO
J7	VSS	K7	VSS	L7	VSS	M7	VDD33IO
J8	VSS	K8	VSS	L8	VDD12CORE	M8	VATAG4/VD9/ GPIO12
J9	VSS	K9	VSS	L9	VSS	M9	VDD33IO
J10	VSS	K10	VSS	L10	VDD12CORE	M10	VATAR5/ GPIO5
J11	VDD33VDAC	K11	VDACREF	L11	VDD33IO	M11	VDD33IO
J12	VDD33VDAC	K12	VDAC_HSYNC	L12	VDD33IO	M12	TDI
J13	VDD33VDAC	K13	VDAC_VSYNC	L13	WS/GPIO29	M13	INT
J14	VDACG	K14	VDACB	L14	MCLK/GPIO25	M14	EECS
J15	nVDACG	K15	nVDACB	L15	SPDIF/I2SDATA/ GPIO26	M15	EECLK

Table 2.12 225-LFBGA Package Pin Assignments (continued)

PIN NUM	PIN NAME	PIN NUM	PIN NAME	PIN NUM	PIN NAME	PIN NUM	PIN NAME
N1	XI	P1	XO	R1	SYSPLL		
N2	VDD12USBPLL	P2	SYSPLLG	R2	VATAB7/VD0/ GPIO23		
N3	USBRBIAS	P3	VATAB6/VD1/ GPIO22	R3	VATAB5/VD2/ GPIO21		
N4	VATAB3/VD4/ GPIO19	P4	VATAB2/VD5/ GPIO18	R4	VATAB1/VD6/ GPIO17		
N5	VATAB0/ GPIO16	P5	HSYNC	R5	VSYNC		
N6	nBLANK	P6	nVCLK	R6	VCLK		
N7	VDTAG7/ GPIO15	P7	VDTAG6/VD7/ GPIO14	R7	VDTAG5/VD8/ GPIO13		
N8	VDTAG3/ GPIO11	P8	VDTAG2/ GPIO10	R8	VDTAG1/VD10/ GPIO9		
N9	VDTAG0/VD11/ GPIO8	P9	VDATAR7/VD12/ GPIO7	R9	VDATAR6/ GPIO6		
N10	VDATAR4/VD13/ GPIO4	P10	VDATAR3/VD14/ GPIO3	R10	VDATAR2/VD15/ GPIO2		
N11	VDATAR1/ GPIO1	P11	VDATAR0/ I2SCLKALT0/ GPIO0	R11	nTRST		
N12	TDO	P12	TCK	R12	TMS		
N13	nEXTRST	P13	nSW_MODE	R13	NC		
N14	NC	P14	nRESET	R14	LED/ I2SCLKALT1/ GPIO24		
N15	NC	P15	EEDI	R15	EEDO		

## 2.2 Buffer Types

Table 2.13 Buffer Types

BUFFER TYPE	DESCRIPTION
IS	Schmitt-triggered Input
O8	Output with 8mA sink and 8mA source
OD8	Open-drain output with 8mA sink
O12	Output with 12mA sink and 12mA source
OD12	Open-drain output with 12mA sink
PU	50uA (typical) internal pull-up. Unless otherwise noted in the pin description, internal pull-ups are always enabled. <b>Note:</b> Internal pull-up resistors prevent unconnected inputs from floating. Do not rely on internal resistors to drive signals external to the device. When connected to a load that must be pulled high, an external resistor must be added.
PD	50uA (typical) internal pull-down. Unless otherwise noted in the pin description, internal pull-downs are always enabled. <b>Note:</b> Internal pull-down resistors prevent unconnected inputs from floating. Do not rely on internal resistors to drive signals external to the device. When connected to a load that must be pulled low, an external resistor must be added.
AI	Analog input
AO	Analog output
AIO	Analog bi-directional
DDR2I	DDR2 input
DDR2O	DDR2 output
RGB	RGB output
ICLK	Crystal oscillator input pin
OCLK	Crystal oscillator output pin
P	Power pin

# Chapter 3 Power Connections

Figure 3.1 illustrates the power connections for UFX6000.

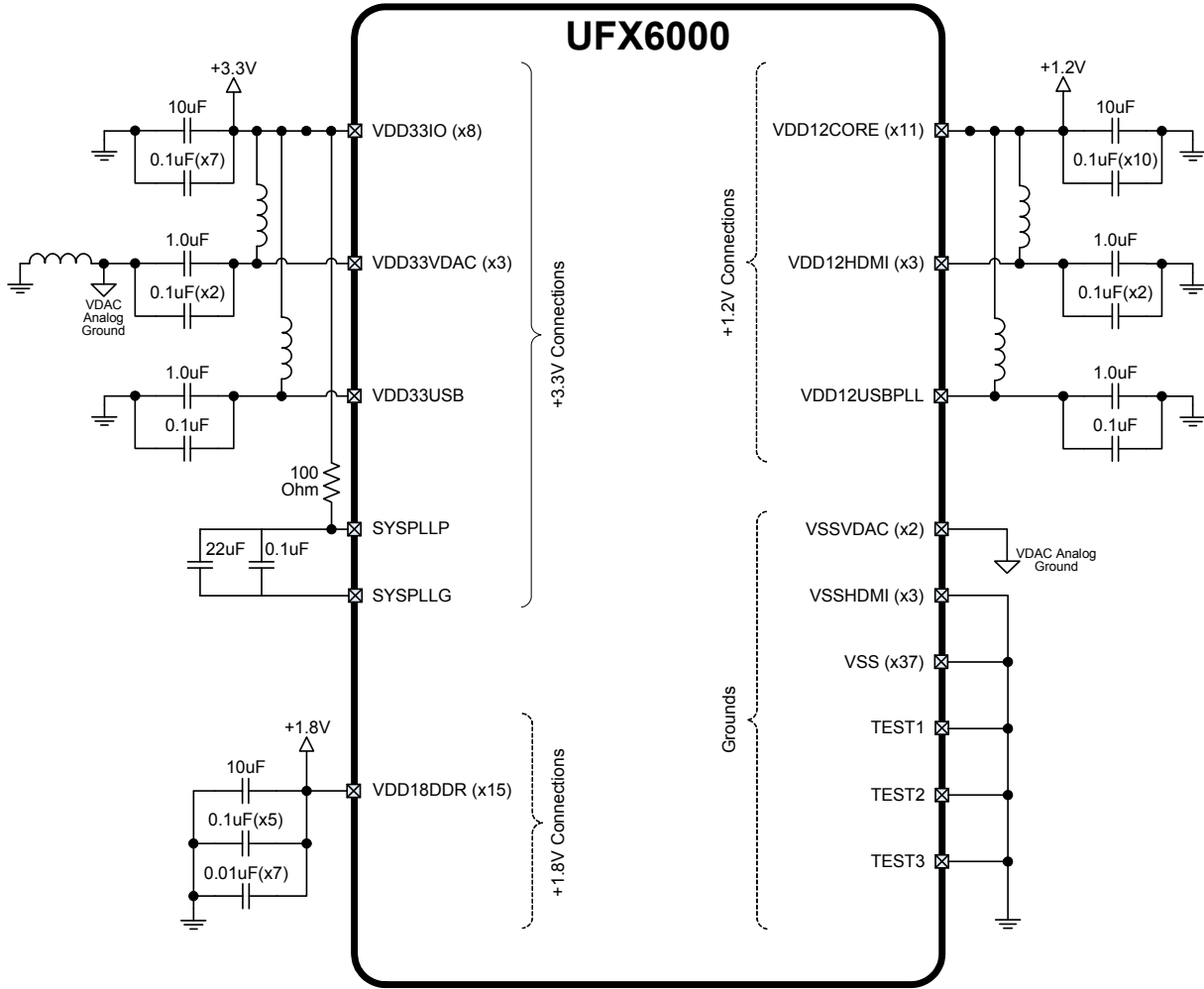

Figure 3.1 Power Connections

**Note:** For additional power connection information, refer to the UFX6000 reference schematic.

## Chapter 4 EEPROM

UFX6000 uses an EEPROM to store the default values for the USB descriptors. It supports most Atmel 93C46x type of EEPROMs.

**Note:** A 3-wire style 4K EEPROM that is organized for 256/512 x 8-bit operation must be used.

Various system level resets cause the EEPROM contents to be loaded into the UFX6000. After a reset, the EEPROM controller attempts to read the first byte of data from the EEPROM. If the value 0xA5 is read from the first address, then the EEPROM controller will assume that an external Serial EEPROM is present.

The EEPROM Controller will then load the entire contents of the EEPROM into an internal 512 byte SRAM. The contents of the SRAM are accessed by the device as needed (i.e., to fill Get Descriptor commands).

The UFX6000 may not respond to the USB host until the EEPROM loading sequence has completed. Therefore, after reset the USB PHY is kept in the disconnect state until the EEPROM load has completed.

The EEPROM Controller also allows the Host system to read, write and erase the contents of the Serial EEPROM.

### 4.1 EEPROM Format

Table 4.1 illustrates the format in which data is stored inside of the EEPROM.

Note the EEPROM offsets are given in units of 16-bit word offsets. A length field with a value of zero indicates that the field does not exist in the EEPROM. The UFX6000 will use the field's hardware default value in this case.

**Note:** For the device descriptor the only valid values for the length are 0 and 18.

**Note:** For the configuration and interface descriptor, the only valid values for the length are 0 and 18.

**Note:** For the BOS Block, the length varies and is dependent on block components.

**Note:** For the SS Configuration Block, the only valid values for the length are 0 and 1Eh.

**Note:** The EEPROM programmer must ensure that if a string descriptor does not exist in the EEPROM, the referencing descriptor must contain 00h for the respective string index field.

**Note:** If all string descriptor lengths are zero, then a Language ID will not be supported.

**Note:** All reserved EEPROM bits must be set to 0.

**Table 4.1 EEPROM Format**

<b>EEPROM ADDRESS</b>	<b>EEPROM CONTENTS</b>
00h	0xA5
01h	Full-Speed Polling Interval for Interrupt Endpoint
02h	Hi-Speed Polling Interval for Interrupt Endpoint
03h	RESERVED
04h	Configuration Flags 0 [7:0]
05h	Configuration Flags 0 [15:8]
06h	Configuration Flags 0 [23:16]
07h	Configuration Flags 0 [31:24]
08h - 13h	RESERVED
14h	Software Configuration Data Structure Length (bytes) <a href="#">Note 4.1</a>
15h	Software Configuration Data Structure Word Offset <a href="#">Note 4.1</a>
16h - 1Fh	RESERVED
20h	Enable bits for GPIOs [7:0] 0 = GPIO 1 = Default pin function
21h	Enable bits for GPIOs [15:8] 0 = GPIO 1 = Default pin function
22h	Enable bits for GPIOs [23:16] 0 = GPIO 1 = Default pin function
23h	Enable bits for GPIOs [31:24] 0 = GPIO 1 = Default pin function
24h	Buffer type bits for GPIOs [7:0] 0 = Open-drain driver 1 = Push/pull driver
25h	Buffer type bits for GPIOs [15:8] 0 = Open-drain driver 1 = Push/pull driver
26h	Buffer type bits for GPIOs [23:16] 0 = Open-drain driver 1 = Push/pull driver

**Table 4.1 EEPROM Format (continued)**

<b>EEPROM ADDRESS</b>	<b>EEPROM CONTENTS</b>
27h	Buffer type bits for GPIOs [31:24] 0 = Open-drain driver 1 = Push/pull driver
28h	Direction bits for GPIOs [7:0] 0 = Input 1 = Output
29h	Direction bits for GPIOs [15:8] 0 = Input 1 = Output
2Ah	Direction bits for GPIOs [23:16] 0 = Input 1 = Output
2Bh	Direction bits for GPIOs [31:24] 0 = Input 1 = Output
2Ch	Data bits for GPIOs [7:0] If GPIO is enabled as an output, the corresponding bit determines the signal level on the pin.
2Dh	Data bits for GPIOs [15:8] If GPIO is enabled as an output, the corresponding bit determines the signal level on the pin.
2Eh	Data bits for GPIOs [23:16] If GPIO is enabled as an output, the corresponding bit determines the signal level on the pin.
2Fh	Data bits for GPIOs [31:24] If GPIO is enabled as an output, the corresponding bit determines the signal level on the pin.
30h	Language ID [7:0]
31h	Language ID [15:8]
32h	Manufacturer ID String Descriptor Length (bytes)
33h	Manufacturer ID String Descriptor EEPROM Word Offset
34h	Product Name String Descriptor Length (bytes)
35h	Product Name String Descriptor EEPROM Word Offset
36h	Serial Number String Descriptor Length (bytes)
37h	Serial Number String Descriptor EEPROM Word Offset
38h	Configuration String Descriptor Length (bytes)
39h	Configuration String Descriptor Word Offset
3Ah	Interface String Descriptor Length (bytes)
3Bh	Interface String Descriptor Word Offset



**Table 4.1 EEPROM Format (continued)**

EEPROM ADDRESS	EEPROM CONTENTS
3Ch	Binary Object Store (BOS) Block Length (bytes) <a href="#">Note 4.2</a>
3Dh	Binary Object Store (BOS) Block Word Offset
3Eh - 41h	RESERVED
42h	Hi-Speed Device Descriptor Length (bytes)
43h	Hi-Speed Device Descriptor Word Offset
44h	Hi-Speed Configuration and Interface Descriptor Length (bytes)
45h	Hi-Speed Configuration and Interface Descriptor Word Offset
46h	Full-Speed Device Descriptor Length (bytes)
47h	Full-Speed Device Descriptor Word Offset
48h	Full-Speed Configuration and Interface Descriptor Length (bytes)
49h	Full-Speed Configuration and Interface Descriptor Word Offset

**Note:** Locations 4Ah and above may be used for any purpose.

**Note 4.1** Refer to the software programming manual for information concerning this data structure.

**Note 4.2** This block may include Binary Object Store (BOS) Descriptor, USB 2.0 Extension Descriptor, and Container ID Descriptor.

[Table 4.2](#) describes [Configuration Flags 0](#). If a configuration descriptor exists in the EEPROM, its values must agree with analogous values contained in the [Configuration Flags 0](#). If they do not, unexpected results and untoward operation may occur.

**Table 4.2 Configuration Flags 0**

BITS	DESCRIPTION
31:13	<b>RESERVED</b>
12	<p><b>Port Swap</b> Swaps the mapping of the USBDP and USBDM pins.</p> <p>0 = USBDP maps to the USB D+ line and USBDM maps to the USB D- line. 1 = USBDP maps to the USB D- line. USBDM maps to the USB D+ line.</p>
11	<p><b>SW_MODE Polarity</b> This bit selects the polarity of the nSW_MODE pin.</p> <p>0 = Active low 1 = Active high</p>
10	<p><b>LED Buffer Type</b> Specifies the LED output buffer type.</p> <p>0 = open-drain driver 1 = push/pull driver</p>

**Table 4.2 Configuration Flags 0 (continued)**

BITS	DESCRIPTION
9	<b>LED Polarity</b> Indicates the polarity of the LED pin.  0 = Active low 1 = Active high
8	<b>LED Enable</b> 0 = LED disabled 1 = LED enabled
7	<b>Interrupt Pin Polarity</b> Indicates the polarity of the INT pin.  0 = Active low 1 = Active high
6	<b>External Reset Polarity</b> Determines the polarity of the external reset pin (nEXTRST)  0 = Active low 1 = Active high
5:4	<b>Squelch Threshold</b> Varies reference voltage levels for squelch and HS Disconnect.  00 = Default 01 = -25mV Change 10 = +25mV Change 11 = RESERVED
3	<b>LPM Enable</b> This bit enables the support of the Link Power Management (LPM) protocol.  0 = LPM not supported 1 = LPM supported.
2:1	<b>PHY Boost</b> This field provides the ability to boost the electrical drive strength of the HS output current to the upstream port.  00 = Normal electrical drive strength 01 = Elevated electrical drive strength (+4% boost) 10 = Elevated electrical drive strength (+8% boost) 11 = Elevated electrical drive strength (+12% boost)
0	<b>Power Method</b> This bit controls the device's USB power mode.  0 = The device is bus powered. 1 = The device is self powered.

**Note:** LPM Enable and Power method specified in [Configuration Flags 0](#) must agree with analogous quantities specified in descriptors. If they do not, unexpected results and untoward operation may occur.

## 4.2 EEPROM Defaults

The signature value of 0xA5 is stored at address 0. A different signature value indicates to the EEPROM controller that no EEPROM is attached to the device. In this case, the hardware default values used are as shown in [Table 4.3](#).

**Table 4.3 EEPROM Defaults**

FIELD	DEFAULT VALUE
Full-Speed Polling Interval	01h
Hi-Speed Polling Interval	04h
Maximum Burst Size for Bulk-Out Endpoint	07h
<a href="#">Configuration Flags 0</a>	00000008h
Maximum Power	<a href="#">Note 4.3</a>
Vendor ID	0424h
Product ID	9D01h

**Note 4.3** Default value is FAh (500mA)

## 4.3 EEPROM Auto-Load

Certain system level resets (POR, nRESET, and Software Reset) cause the EEPROM contents to be loaded into the device. After a reset, the EEPROM controller attempts to read the first byte of data from the EEPROM. If the value 0xA5 is read from the first address, then the EEPROM controller will assume that an external Serial EEPROM is present.

## 4.4 Customized Operation Without EEPROM

The device provides the capability to customize operation without the use of an EEPROM. Descriptor information and initialization quantities normally fetched from EEPROM and used to initialize descriptors and elements of the Control and Status Registers may be specified via proprietary vendor commands over the USB bus.

## Chapter 5 Operational Characteristics

### 5.1 Absolute Maximum Ratings\*

+3.3V Supply Voltage (VDD33IO, VDD33USB, VDD33VDAC, SYSPLL) (Note 5.1)	0V to +3.6V
+1.8V Supply Voltage (VDD18DDR) (Note 5.1)	0V to +1.9V
+1.2V Supply Voltage (VDD12CORE, VDD12USBPLL, VDD12HDMI) (Note 5.1)	0V to +1.32V
Positive voltage on XI, with respect to ground	+4.6V
Positive voltage on XO, with respect to ground	+2.5V
Storage Temperature	-55°C to +150°C
Lead Temperature Range	Refer to JEDEC Spec. J-STD-020
HBM ESD Performance	JEDEC Class 2

**Note 5.1** When powering this device from laboratory or system power supplies, it is important that the absolute maximum ratings not be exceeded or device failure can result. Some power supplies exhibit voltage spikes on their outputs when AC power is switched on or off. In addition, voltage transients on the AC power line may appear on the DC output. If this possibility exists, it is suggested that a clamp circuit be used.

\*Stresses exceeding those listed in this section could cause permanent damage to the device. This is a stress rating only. Exposure to absolute maximum rating conditions for extended periods may affect device reliability. Functional operation of the device at any condition exceeding those indicated in [Section 5.2, "Operating Conditions\\*\\*"](#), [Section 5.5, "DC Specifications"](#), or any other applicable section of this specification is not implied. Note, device signals are *NOT* 5 volt tolerant unless specified otherwise.

### 5.2 Operating Conditions\*\*

+3.3V Supply Voltage (VDD33IO, VDD33USB, VDD33VDAC, SYSPLL)	+3.3V +/- 5%
+1.8V Supply Voltage (VDD18DDR)	+1.8V +/- 5%
+1.2V Supply Voltage (VDD12CORE, VDD12USBPLL, VDD12HDMI)	+1.2V +/- 5%
Ambient Operating Temperature in Still Air (T <sub>A</sub> )	0°C to +70°C
Maximum Junction Temperature	+110°C

\*\*Proper operation of the device is guaranteed only within the ranges specified in this section.

## 5.3 Package Thermal Specifications

Table 5.1 Package Thermal Parameters

PARAMETER	SYMBOL	VALUE	UNITS	COMMENTS
Thermal Resistance	$\Theta_{JA}$	28.7	°C/W	Measured in still air from the die to ambient air
Thermal Resistance	$\Theta_{JC}$	10.4	°C/W	Measured from the die to the case
Junction-to-Top-of-Package	$\Psi_{JT}$	0.38	°C/W	Measured in still air

**Note:** Thermal parameters are measured or estimated for devices in a multi-layer 2S2P PCB per JE5D51.

## 5.4 Current Consumption

This section details the current consumption of the device as measured during various modes of operation and power states. Current consumption values are provided for each power rail (+3.3V, +1.8V, +1.2V). Power dissipation is determined by temperature, supply voltage, and external source/sink requirements.

**Note:** All current consumption values were measured with power supplies at nominal voltages unless otherwise noted.

### 5.4.1 SUSPEND Power State

Table 5.2 SUSPEND Supply Current

PARAMETER	TYPICAL	UNIT
+3.3V Supply Current (Device Only) (VDD33IO, VDD33USB, VDD33VDAC, SYSPLL)	0.7	mA
+1.8V Supply Current (Device Only) (VDD18DDR)	0.0	mA
+1.2V Supply Current (Device Only) (VDD12CORE, VDD12USBPLL, VDD12HDMI)	1.5	mA

## 5.4.2 Operational

### 5.4.2.1 High-Speed

Table 5.3 Typical High-Speed Operational Supply Current (mA)

PARAMETER	STATIC IMAGE			FULL SCREEN VIDEO		
	1280X1024 (DDR2-667)	1600X1200 (DDR2-667)	1920X1200 (DDR2-667)	1280X1024 (DDR2-667)	1600X1200 (DDR2-667)	1920X1200 (DDR2-667)
<b>Video DAC Interface Enabled</b>						
+3.3V Supply Current (Dev. Only) (VDD33IO, VDD33USB, VDD33VDAC, SYSPLL)	77	78	79	78	78	79
+1.8V Supply Current (Dev. Only) (VDD18DDR)	39	45	48	58	67	75
+1.2V Supply Current (Dev. Only) (VDD12CORE, VDD12USBPLL, VDD12HDMI)	181	189	192	203	215	222
<b>HDMI Interface Enabled (with audio)</b>						
+3.3V Supply Current (Dev. Only) (VDD33IO, VDD33USB, VDD33VDAC, SYSPLL)	5.0	5.0	5.0	5.2	5.2	5.2
+1.8V Supply Current (Dev. Only) (VDD18DDR)	39	45	49	60	67	76
+1.2V Supply Current (Dev. Only) (VDD12CORE, VDD12USBPLL, VDD12HDMI)	201	218	218	223	242	255

## 5.5 DC Specifications

Table 5.4 I/O Buffer Characteristics

PARAMETER	SYMBOL	MIN	TYP	MAX	UNITS	NOTES
IS Type Input Buffer						
Low Input Level	$V_{ILI}$	-0.3			V	
High Input Level	$V_{IHI}$			3.6	V	
Negative-Going Threshold	$V_{ILT}$	1.01	1.19	1.39	V	Schmitt trigger
Positive-Going Threshold	$V_{IHT}$	1.39	1.59	1.8	V	Schmitt trigger
SchmittTrigger Hysteresis ( $V_{IHT} - V_{ILT}$ )	$V_{HYS}$	336	399	485	mV	
O8 Type Output Buffer						
Low Output Level	$V_{OL}$			0.4	V	$I_{OL} = 8\text{mA}$
High Output Level	$V_{OH}$	$V_{DD33IO} - 0.4$			V	$I_{OH} = -8\text{mA}$
OD8 Type Output Buffer						
Low Output Level	$V_{OL}$			0.4	V	$I_{OL} = 8\text{mA}$
RGB Type Output Buffer						
Low Output Level	$V_{OL}$			0.4	V	$I_{OL} = 8\text{mA}$
High Output Level	$V_{OH}$	$V_{DD33IO} - 0.4$			V	$I_{OH} = -8\text{mA}$
DDR2I Type Input Buffer						<a href="#">Note 5.2</a>
Termination Voltage	$V_{TT}$	$V_{REF} - 0.04$	$V_{REF}$	$V_{REF} + 0.04$	V	<a href="#">Note 5.3</a>
Low Input Level (DC)	$V_{IL(dc)}$	-0.3		$V_{REF} - 0.125$	V	<a href="#">Note 5.3</a>
High Input Level (DC)	$V_{IH(dc)}$	$V_{REF} + 0.125$		$V_{DD18DDR} + 0.3$	V	<a href="#">Note 5.3</a>
Low Input Level (AC)	$V_{IL(ac)}$			$V_{REF} - 0.25$	V	<a href="#">Note 5.3</a>
High Input Level (AC)	$V_{IH(ac)}$	$V_{REF} + 0.25$			V	<a href="#">Note 5.3</a>
DDR2O Type Output Buffer						<a href="#">Note 5.2</a>
Termination Voltage	$V_{TT}$	$V_{REF} - 0.04$	$V_{REF}$	$V_{REF} + 0.04$	V	<a href="#">Note 5.3</a>
Low Output Level (DC)	$V_{OL(dc)}$			0.28	V	<a href="#">Note 5.4</a>
High Output Level (DC)	$V_{OH(dc)}$	$V_{DD18DDR(min)} - 0.2$			V	<a href="#">Note 5.5</a>
Low Output Level (AC)	$V_{OL(ac)}$			$V_{TTmin} - 0.603$	V	<a href="#">Note 5.4</a>
High Output Level (AC)	$V_{OH(ac)}$	$V_{TTmax} + 0.603$			V	<a href="#">Note 5.5</a>
ICLK Type Buffer (XI Input)						<a href="#">Note 5.6</a>
Low Input Level	$V_{ILI}$	-0.3		0.5	V	
High Input Level	$V_{IHI}$	1.4		3.6	V	

**Note 5.2** All values apply to both full-strength and half-strength operation unless otherwise stated.

**Note 5.3**  $V_{REF}$  equals  $DDR\text{VREF}[0:2]$ .

**Note 5.4**  $I_{OL}$  equals 13.4mA for full-strength operation and 6.7mA for half-strength operation.

**Note 5.5**  $I_{OH}$  equals -13.4mA for full-strength operation and -6.7mA for half-strength operation.

**Note 5.6** XI can optionally be driven from a 25MHz single-ended clock oscillator.

**Table 5.5 Video DAC - DC Characteristics**

PARAMETER	SYMBOL	MIN	TYP	MAX	UNITS
Output Voltage	-		1.28		V
Output Current per Channel	-		17		mA
Video DAC Resolution	-		10		bits
Integral Non-linearity Error	INL			+/-2	LSB
Differential Non-linearity Error	DNL			+/-0.5	LSB

## 5.6 AC Specifications

This section details the various AC timing specifications of the device.

**Note:** The USB interface timing adheres to the USB 2.0 Specification. Refer to the Universal Serial Bus Revision 2.0 Specification for detailed USB timing information.

**Note:** The DDR2 interface timing adheres to the JESD79-2E Specification. Refer to the JESD79-2E Specification for detailed DDR2 timing information.

**Note:** The HDMI interface timing adheres to the HDMI 1.3 Specification. Refer to the HDMI 1.3 Specification for detailed HDMI timing information.

**Note:** The S/PDIF interface timing adheres to the IEC 60958 2-channel PCM Specification. Refer to the IEC 60958 2-channel PCM Specification for detailed S/PDIF timing information.

**Note:** The I<sup>2</sup>S interface timing adheres to the NXP I<sup>2</sup>S Bus Specification. Refer to the NXP I<sup>2</sup>S Bus Specification for detailed I<sup>2</sup>S timing information.

**Note:** The I<sup>2</sup>C interface timing adheres to the NXP I<sup>2</sup>C-Bus Specification. Refer to the I<sup>2</sup>C-Bus Specification for detailed I<sup>2</sup>C timing information.



### 5.6.1 Power Sequence Timing

Power supplies must adhere to the following rules:

- All power supplies of the same voltage must be powered up/down together.
- There is no power-up sequencing requirement, however all power supplies must reach operational levels within the time periods specified in [Table 5.6](#).
- There is no power-down sequencing or timing requirement, however the device must not be powered for an extended period of time without all supplies at operational levels.
- Following power-on, or if a power supply brownout occurs (i.e., one or more supplies drops below operational limits), a power-on reset must be executed once all power supplies reach operational levels. Refer to section [Section 5.6.2, "Power-On Reset Timing," on page 42](#) for power-on reset requirements.
- With the exception of HPD, VBUS\_DET, I2CSDA[0:1], and I2CSCL[0:1], do not drive input signals without power supplied to the device.

**Note:** Violation of these specifications may damage the device.

**Note:** Power sequencing requirements are preliminary and subject to change.

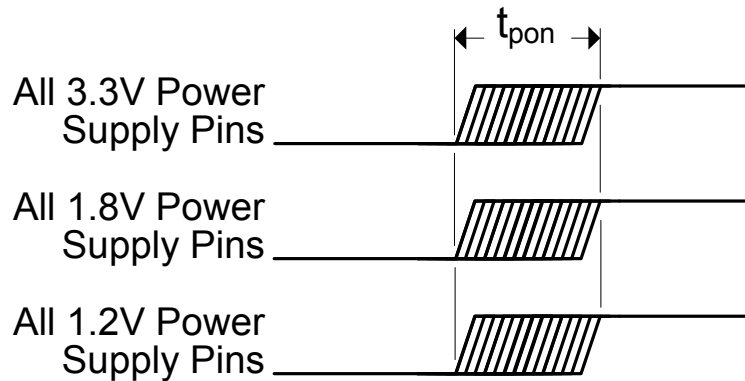

Figure 5.1 Power-On Timing

Table 5.6 Power-On Timing Values

SYMBOL	DESCRIPTION	MIN	TYP	MAX	UNITS
$t_{pon}$	Power supply turn on time	0		25	mS

### 5.6.2 Power-On Reset Timing

This diagram illustrates the nRESET timing requirements in relation to power-on. A hardware reset (nRESET assertion) is required following power-up. For proper operation, nRESET must be asserted for no less than  $t_{rstia}$ . The nRESET pin can be asserted at any time, but must not be deasserted before  $t_{purstd}$  after all external power supplies have reached operational levels.

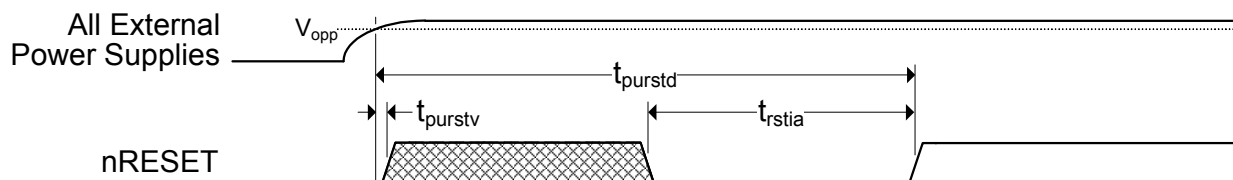

Figure 5.1 nRESET Power-On Timing

Table 5.7 nRESET Power-On Timing Values

SYMBOL	DESCRIPTION	MIN	TYP	MAX	UNITS
$t_{purstd}$	External power supplies at operational levels to nRESET deassertion	25	Note 5.7		mS
$t_{purstv}$	External power supplies at operational levels to nRESET valid	0			nS
$t_{rstia}$	nRESET input assertion time	100			$\mu$ S

**Note:** nRESET deassertion must be monotonic.

**Note 5.7** For bus-powered applications, a typical value of 200 mS is recommended to allow time for connector mating. Permanently attached and/or self-powered applications do not require this longer reset time.

### 5.6.3 Reset Timing

Figure 5.1 illustrates the nRESET pin timing requirements. When used, nRESET must be asserted for no less than  $t_{rstia}$ .

**Note:** A hardware reset (nRESET assertion) is required following power-on. Refer to Section 5.6.2, "Power-On Reset Timing," on page 42 for additional information.

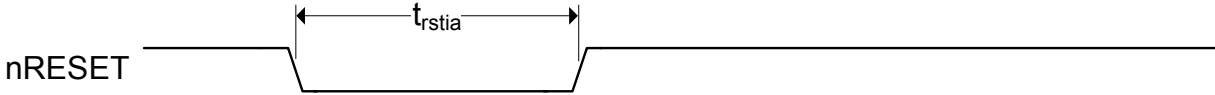

Figure 5.1 nRESET Timing

Table 5.8 nRESET Timing Values

SYMBOL	DESCRIPTION	MIN	TYP	MAX	UNITS
$t_{rstia}$	nRESET input assertion time	1			uS

### 5.6.4 Video DAC Timing

The following table specifies the Video DAC timing characteristics for the device. All values are measured with the Video DAC in 17mA full scale mode.

Table 5.9 Video DAC - AC Characteristics

PARAMETER	MIN	TYP	MAX	UNITS
Frequency	25		200	MHz
Analog Output Delay	0.4	0.5	0.8	nS
Analog Output Rise Time		0.31		nS
Analog Output Fall Time		0.5		nS
Analog Output Settling Time		0.7		nS

### 5.6.5 Digital RGB Timing

The following sub-sections specify the Digital RGB timing requirements for the device in DDR and SDR modes of operation.

#### 5.6.5.1 DDR Mode

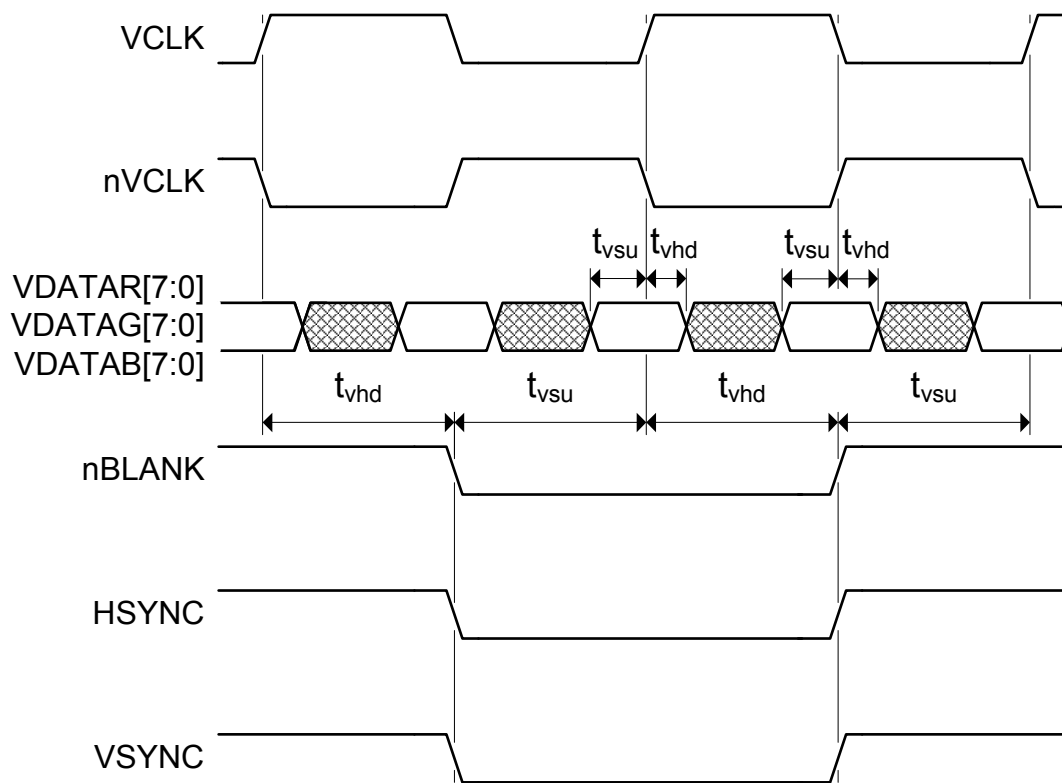

Figure 5.2 Digital RGB Timing - DDR Mode

Table 5.10 Digital RGB Timing Values - DDR Mode

SYMBOL	DESCRIPTION	MIN	TYP	MAX	UNITS
$f_{vclk}$	VCLK Frequency			165	MHz
$t_{vsu}$	Video Setup Output Delay	0.8			nS
$t_{vhd}$	Video Hold Output Delay	0.5			nS

**Note:** RGB timing values are with respect to an equivalent test load of 5 pF.

5.6.5.2 SDR Mode

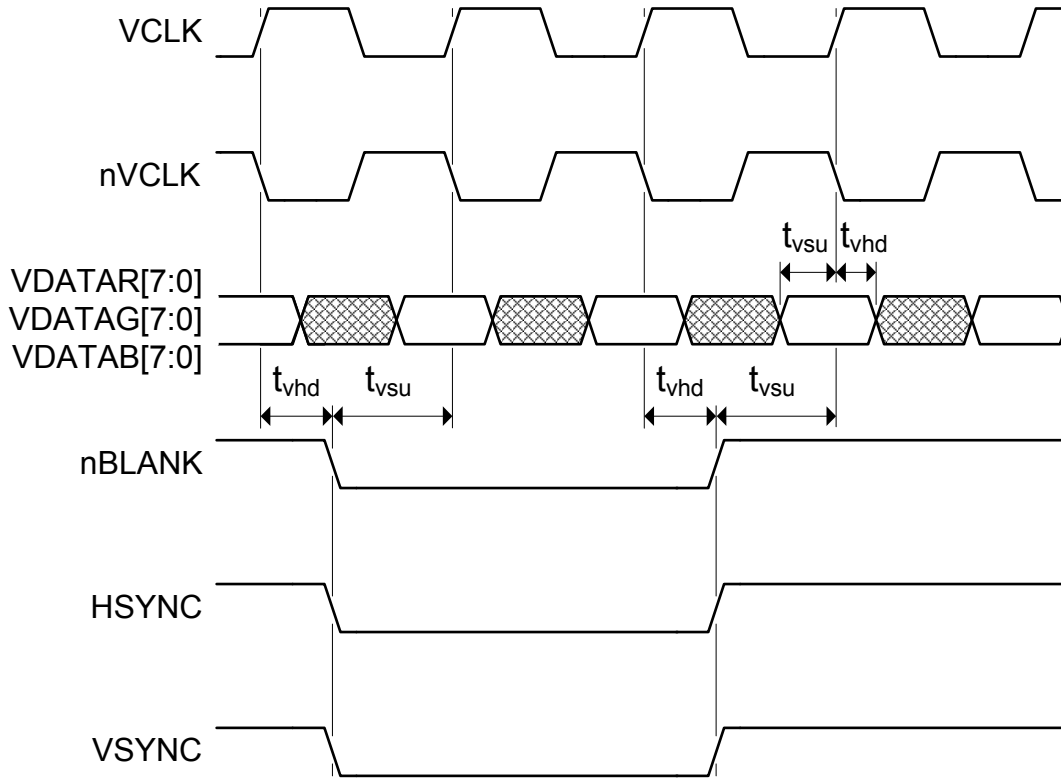

Figure 5.3 Digital RGB Timing - SDR Mode

Table 5.11 Digital RGB Timing Values - SDR Mode

SYMBOL	DESCRIPTION	MIN	TYP	MAX	UNITS
$f_{vclk}$	VCLK Frequency			165	MHz
$t_{vsu}$	Video Setup Output Delay	2.5			nS
$t_{vhd}$	Video Hold Output Delay	1.5			nS

**Note:** RGB timing values are with respect to an equivalent test load of 5 pF.

## 5.6.6 EEPROM Timing

The following specifies the EEPROM timing requirements for the device:

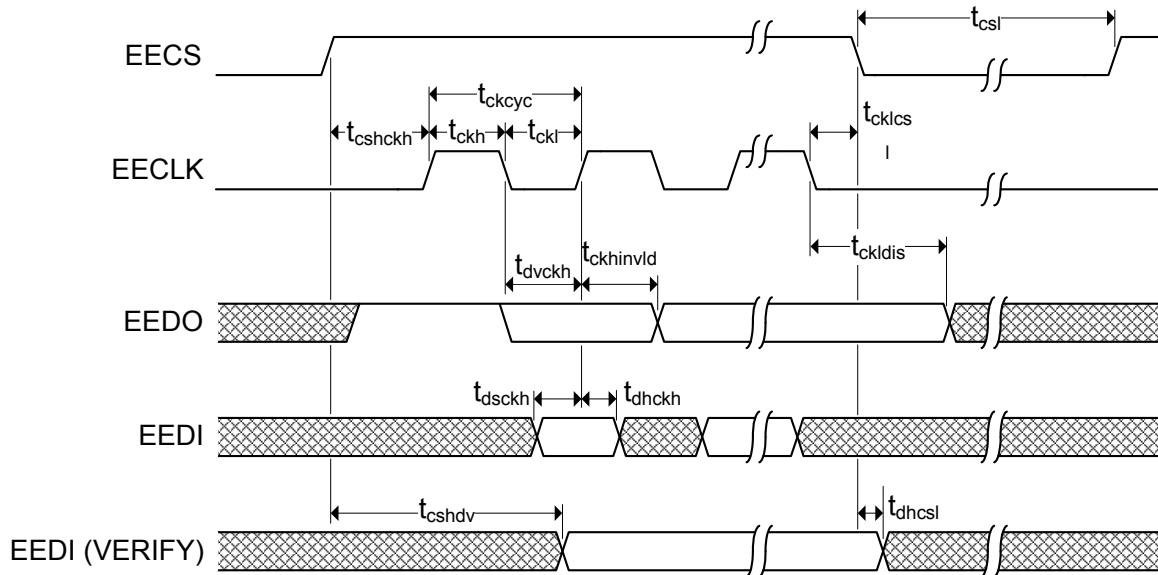

Figure 5.4 EEPROM Timing

Table 5.12 EEPROM Timing Values

SYMBOL	DESCRIPTION	MIN	TYP	MAX	UNITS
$t_{ckcyc}$	EECLK Cycle time	1110		1130	ns
$t_{ckh}$	EECLK High time	550		570	ns
$t_{ckl}$	EECLK Low time	550		570	ns
$t_{cshckh}$	EECS high before rising edge of EECLK	1070			ns
$t_{cklcsl}$	EECLK falling edge to EECS low	30			ns
$t_{dvckh}$	EEDO valid before rising edge of EECLK	550			ns
$t_{ckhinvid}$	EEDO invalid after rising edge EECLK	550			ns
$t_{dsckh}$	EEDI setup to rising edge of EECLK	90			ns
$t_{dhckh}$	EEDI hold after rising edge of EECLK	0			ns
$t_{ckldis}$	EECLK low to data disable (OUTPUT)	580			ns
$t_{cshdv}$	EEDIO valid after EECS high (VERIFY)			600	ns
$t_{dhcsl}$	EEDIO hold after EECS low (VERIFY)	0			ns
$t_{csl}$	EECS low	1070			ns

**Note:** EEPROM timing values are with respect to an equivalent test load of 25 pF.

### 5.6.7 JTAG Timing

This section specifies the JTAG timing of the device.

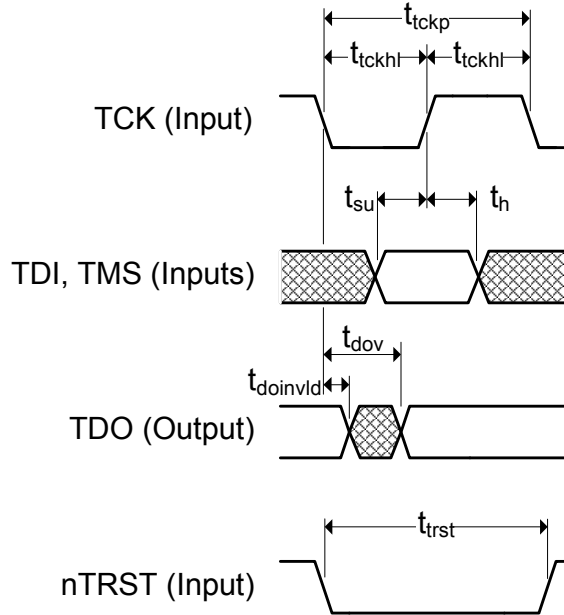

Figure 5.5 JTAG Timing

Table 5.13 JTAG Timing Values

SYMBOL	DESCRIPTION	MIN	MAX	UNITS	NOTES
$t_{tckp}$	TCK clock period	66.67	80	nS	
$t_{tckhl}$	TCK clock high/low time	$t_{tckp} * 0.4$	$t_{tckp} * 0.6$	nS	
$t_{su}$	TDI, TMS setup to TCK rising edge	10		nS	
$t_h$	TDI, TMS hold from TCK rising edge	10		nS	
$t_{dov}$	TDO output valid from TCK falling edge		16	nS	
$t_{doinvld}$	TDO output invalid from TCK falling edge	0		nS	
$t_{trst}$	nTRST assertion time	10		mS	

**Note:** JTAG timing values are with respect to an equivalent test load of 25 pF.

## 5.7 Clock Circuit

The device can accept either a 25MHz crystal or a 25MHz single-ended clock oscillator (+/- 50ppm) input. If the single-ended clock oscillator method is implemented, XO should be left unconnected and XI should be driven with a nominal 0-3.3V clock signal. The input clock duty cycle is 40% minimum, 50% typical and 60% maximum.

It is recommended that a crystal utilizing matching parallel load capacitors be used for the crystal input/output signals (XI/XO). See [Table 5.14](#) for the recommended crystal specifications.

**Table 5.14 Crystal Specifications**

PARAMETER	SYMBOL	MIN	NOM	MAX	UNITS	NOTES
Crystal Cut	AT, typ					
Crystal Oscillation Mode	Fundamental Mode					
Crystal Calibration Mode	Parallel Resonant Mode					
Frequency	$F_{fund}$	-	25.000	-	MHz	
Frequency Tolerance @ 25°C	$F_{tol}$	-	-	+/-50	PPM	<a href="#">Note 5.8</a>
Frequency Stability Over Temp	$F_{temp}$	-	-	+/-100	PPM	<a href="#">Note 5.8</a>
Frequency Deviation Over Time	$F_{age}$	-	+/-3 to 5	-	PPM	<a href="#">Note 5.9</a>
Total Allowable PPM Budget		-	-	+/-150	PPM	
Shunt Capacitance	$C_O$	-	7 typ	-	pF	
Load Capacitance	$C_L$	-	20 typ	-	pF	
Drive Level	$P_W$	300	-	-	uW	
Equivalent Series Resistance	$R_1$	-	-	50	Ohm	
Operating Temperature Range		0	-	70	°C	
XI Pin Capacitance		-	3 typ	-	pF	<a href="#">Note 5.10</a>
XO Pin Capacitance		-	3 typ	-	pF	<a href="#">Note 5.10</a>

**Note 5.8** The maximum allowable values for Frequency Tolerance and Frequency Stability are application dependant.

**Note 5.9** Frequency Deviation Over Time is also referred to as Aging.

**Note 5.10** This number includes the pad, the bond wire and the lead frame. PCB capacitance is not included in this value. The XO/XI pin and PCB capacitance values are required to accurately calculate the value of the two external load capacitors. These two external load capacitors determine the accuracy of the 25.000 MHz frequency.



# Chapter 6 Package Outline

## 6.1 225-LFBGA Package

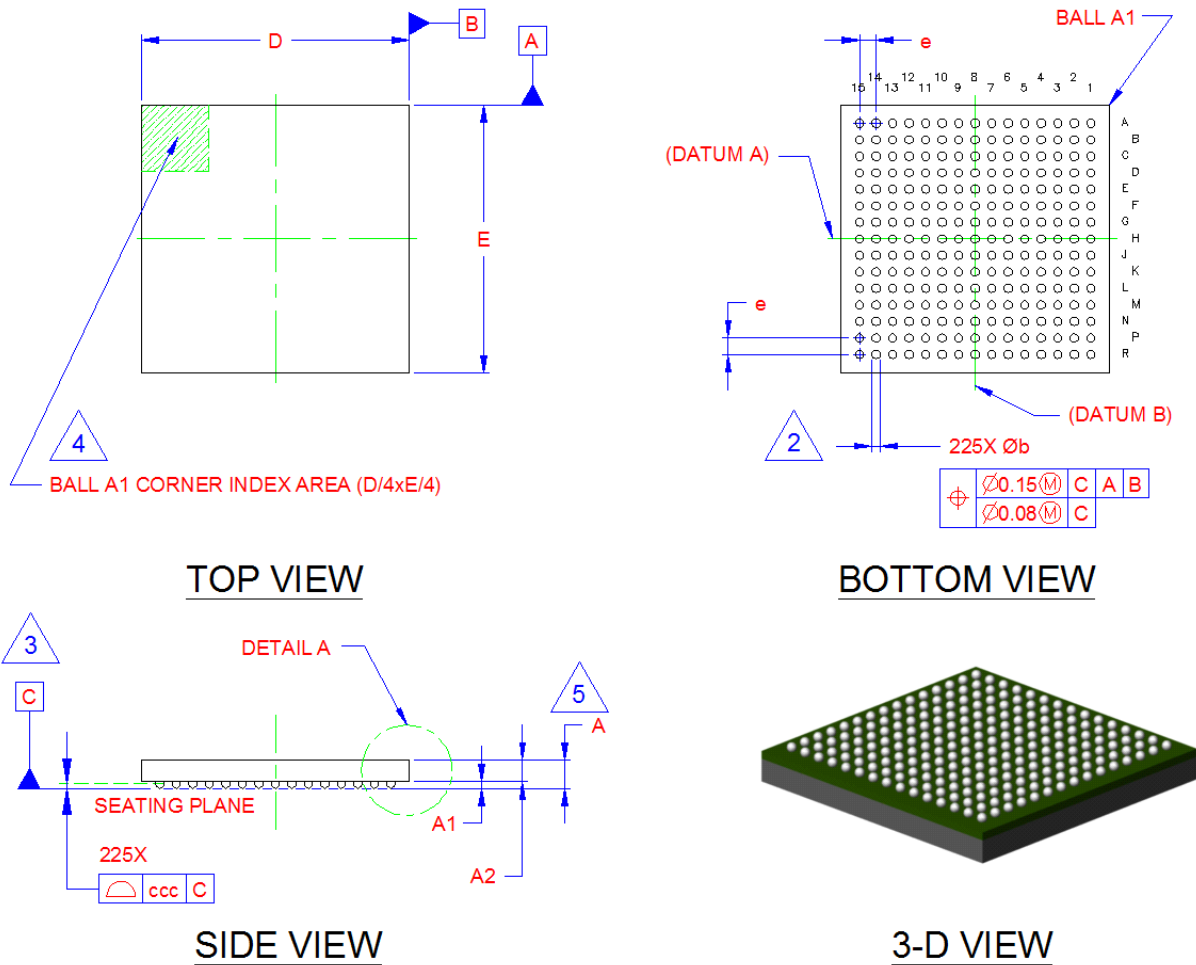

Figure 6.1 225-LFBGA Package Definition

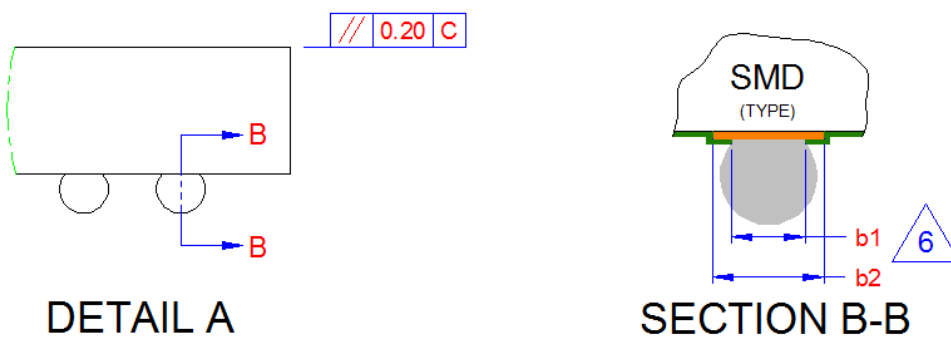

Figure 6.2 225-LFBGA Package Ball Detail

**Table 6.1 225-LFBGA Package Parameters**

	MIN	NOMINAL	MAX	REMARKS
A	-	1.30	1.40	Overall Package Height
A1	0.25	-	0.40	Standoff
A2	0.65	0.96	-	Package Body Thickness
D/E	12.90	13.00	13.10	Overall Package Size
b	0.40	0.45	0.50	Ball Diameter
b1	0.35	0.40	0.45	Finished Solder Mask Opening
b2	0.45	0.50	0.55	Finished Ball Pad Diameter
e	0.80 BSC			Ball Pitch
ccc	-	-	0.20	Coplanarity

**Notes:**

1. All dimensions are in millimeters.
2. Dimension "b" is measured at the maximum ball diameter, parallel to primary datum "C".
3. Primary datum "C" (seating plane) is defined by the spherical crowns of the contact balls.
4. The ball A1 identifier may vary, but is always located within the zone indicated.
5. Dimension "A" does not include attached external features, such as heat sink or chip capacitors.
6. The package ball solderable surface is Solder-Mask-Defined (SMD) type.

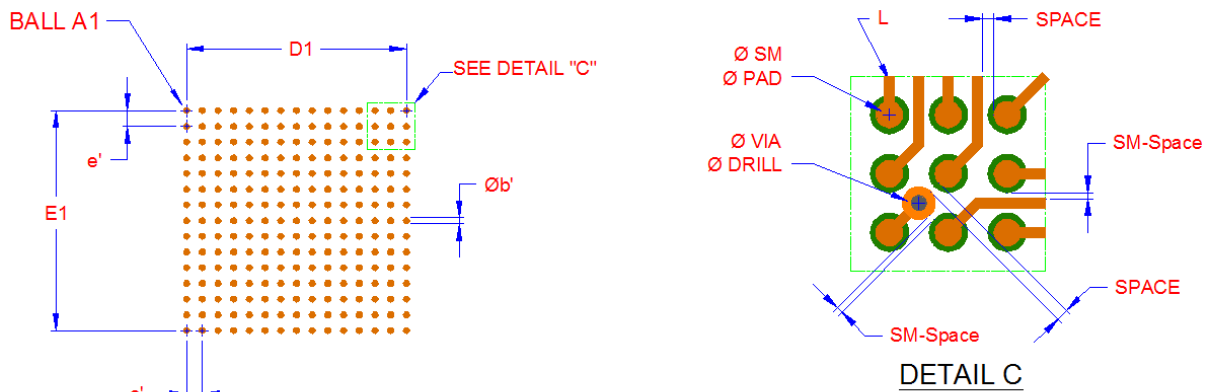

PCB LAND PATTERN DIMENSIONS			
SYMBOL	MIN	NOM	MAX
D1/E1	-	11.20	-
e'	0.80 BSC		

THE USER MAY MODIFY THE PCB LAND PATTERN & ROUTING DIMENSIONS, BASED ON THEIR EXPERIENCE AND/OR PROCESS CAPABILITY

ROUTING DIMENSIONS	
SYMBOL	NOM
Ø PAD	0.40
Ø SM	0.50
L (Trace)	0.125
SPACE	0.135
SM-Space	0.09
Ø VIA PAD	0.45
Ø DRILL	0.25

**Figure 6.1 225-LFBGA Recommended PCB Land Pattern**

## Chapter 7 Datasheet Revision History

**Table 7.1 Customer Revision History**

REVISION LEVEL & DATE	SECTION/FIGURE/ENTRY	CORRECTION
Rev. 1.3 (09-27-12)	Table 2.2, "Digital RGB Pins," on page 9 and Table 2.9, "Miscellaneous Pins," on page 21	Added note to Buffer Type column of all GPIO pin descriptions: "The internal pull-up is disabled when the GPIO is configured as an O8 buffer type."
	Table 2.9, "Miscellaneous Pins," on page 21	Added note to SPDIF pin "Usage of SPDIF requires the MCLK audio input master clock pin."
Rev. 1.2 (09-16-11)	Section 5.4.2, "Operational," on page 38	Added final power numbers.
	Chapter 6, "Package Outline," on page 49	Updated package drawings & specifications.
Rev. 1.1 (05-13-11)	Section 5.2, "Operating Conditions**," on page 36	+3.3V, +1.8V, and +1.2V power supply operating ranges updated to +/-5%. Junction temperature updated to show maximum only.
	Table 2.1, "USB Pins," on page 9, Table 2.2, "Digital RGB Pins," on page 9, Note 5.6 on page 40, and Section 5.7, "Clock Circuit," on page 48	Added note regarding not using a crystal in Digital RGB mode: "A 25Mhz oscillator, or other single ended clock source that meets the specifications in Sections 5.5 and 5.7, is required when utilizing the Digital RGB interface. Do not use a crystal when operating in Digital RGB mode."
Rev. 1.0 (12-16-10)	All	Initial Release