

DVB-H Tuners

Making TV On the Go Possible

Portability is a natural evolution for consumer electronics, from the first transistor radios to PDAs with the computing power of yesterday's desktop. Now Freescale is part of the next step in wireless evolution; TV on the go.

Freescale's digital video broadcast for handhelds (DVB-H) solution is engineered to enable easy, cost-effective mobile broadcast solutions for consumers. Freescale is helping to make digital video broadcast reception possible on cellular handsets and other mobile devices via the development of very low-power tuner integrated circuits. The Freescale DVB-H tuners are engineered to achieve very low power consumption and are optimized for battery powered mobile applications.

Freescale RF is part of a front-end reference design providing DVB-H connectivity to a wide variety of wireless end products, as well as terrestrial broadcast (DVB-T) in portable media players.

The DVB-H Standard

Freescale is actively supporting the development of the DVB-H standard and is a member of the Mobile DTV Alliance. The DVB-H standard was formally adopted as a European Telecommunications Standards Institute (ETSI) standard in November 2004. In February 2005, the Digital Video Broadcasting (DVB) Project approved a significant report verifying the performance of the DVB-H standard. The DVB Project is an industry-led consortium of over 260 broadcasters, manufacturers, network operators, software developers, regulatory bodies and others from more than 35 countries who are committed to designing global standards for the delivery of digital television and data services.

The DVB-H standard builds on existing DVB-T infrastructure to reach wide coverage with limited incremental investments. This allows the cellular handset to receive IP data from the network while a cellular link is used as a return channel for data and interactive applications. DVB-H is a perfect complement to 2G and 3G cellular networks, providing the high bandwidth necessary to implement broadcast applications.



ZIF Approach

Freescale's direct conversion, zero intermediate frequency (ZIF) approach allows for low power consumption and a low part count. These factors enable extended battery life in a small form factor that can be easily integrated into a solution ideal for DVB-H enabled handheld requirements.

Features

- Drives higher performance
- Improves reception quality
- Enables DVB-H services in a variety of severe conditions, such as strong interference
- Follows the proven performance guidelines of the MBRAI specification
- Integrates DVB-H into any mobile device as a plug-and-play feature

Freescale DVB-H Tuner Solution

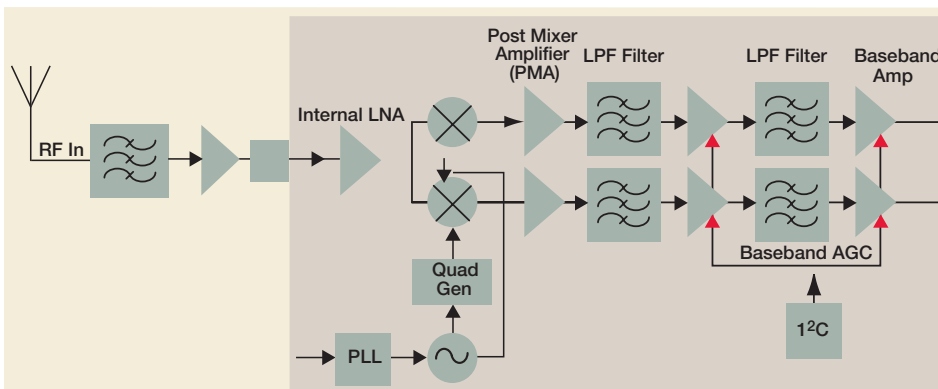

In the Palm of Your Hand

The latest solutions from Freescale answer the demand for optimal performance, size, power consumption and cost for integrated DVB-H capability for cellular and personal media devices.

Freescale has developed a reference design for a personal media player that can broadcast, pause and record live television. This solution is based upon Freescale's DVB-H RF tuner and the i.MX31 high-speed applications processor. In addition to making TV on the go possible, this solution enables long battery life and crisp video resolution, as well as advanced security, 3-D gaming and navigation features.

MC44CD02 Tuner IC

Targeted for handheld devices such as integrated cellular phones, the MC44CD02 is compliant with the DVB-H standard and is designed to provide minimal power consumption with optimum performance. The MC44CD02 features three modes of operation; normal, power down and deep sleep. The MC44CD02 covers the UHF bands IV and V (470 MHz–862 MHz) and is able to handle 6, 7 and 8 MHz channels in this range.

Features

- Low power operation (2.775V, 98 mA current drain, i.e. 270 mW during bursts)
- Power down and deep sleep battery saving modes of operation
- Full UHF range of operation (470 MHz to 862 MHz)
- Integrated channel filters (6, 7 and 8 MHz channel width)
- Low external component count
- I²C bus controlled

Freescale DVB-H Technology Platform

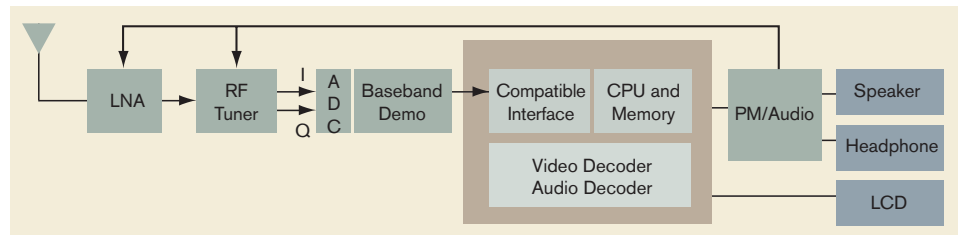

- Integrated low phase noise phase-lock loop (PLL) with 4 GHz voltage control oscillators (VCO) and quadrature generator for precise I and Q local oscillator generation
- 166.67 kHz synthesizer step size
- Integrated wideband RF power detector with output signal to the baseband demodulator
- 36 MHz or 26 MHz crystal oscillator and clock outputs (either custom LVDS or single ended) toward the baseband demodulator
- 36 MHz or 26 MHz clock reference can also be used
- General-purpose digital output (LOP), which can be used to control the gain of an external low noise amplifier
- Lead-free QFN48, 7 mm x 7 mm, 0.5 mm pitch exposed pad package, ultra-small WL-CSP package in development

MC44CD03 1.67 GHz Receiver

The MC44CD03 device is compliant with the DVB-H standard and features four modes of operation; normal, low power operation, power down and deep sleep. The MC44CD03 covers the range of 1665 MHz–1680 MHz and operates on center frequencies of 1667.5 MHz, 1672.5 MHz or 1677.5 MHz. The channel bandwidth is 5 MHz.

Features

- Normal power operation (2.775V, 100 mA current drain, i.e., 280 mW during bursts)
- Reduced power operation (235 mW) with reduced filtering
- Power down and deep sleep battery save modes of operation
- Low external component count, no external LNA required
- I²C bus controlled
- Integrated low phase noise PLL with 3.5 GHz VCO and quadrature generator for precise I and Q local oscillator generation
- 500 kHz synthesizer step size
- Integrated filter tracking loop to maintain the cutoff frequency over all process variations
- 36 MHz or 26 MHz crystal oscillator with clock outputs (either custom LVDS or single-ended) to the baseband demodulator
- General-purpose digital output (LOP)
- Lead-free thin QFN40, 6 mm x 6 mm, 0.5 mm pitch exposed pad package

Learn More: For current information about Freescale products and documentation, please visit www.freescale.com.

You can also find more information about DVB-H tuners at Freescale's online support services center, www.freescale.com/mobileTV.