

# DATA SHEET

## **XA-H4**

Single-chip 16-bit microcontroller

Preliminary specification  
IC28 Data Handbook

1999 Sep 24

# Single-chip 16-bit microcontroller

# XA-H4

## DESCRIPTION

The powerful 16-bit XA CPU core and rich feature set make the XA-H3 and XA-H4 devices ideal for high-performance real-time applications such as industrial control and networking. By supporting of up to 32 MB of external memory, these devices provide a low-cost solution to embedded applications of any complexity. Features like DMA, memory controller and four advanced USARTs help solve I/O intensive tasks with a minimum of CPU load.

The XA-H3 feature set is a subset of the XA-H4 (see Table 1). The XA-H3/H4 devices are members of the Philips XA (eXtended Architecture) family of high performance 16-bit microcontrollers.

The XA-H3 and XA-H4 are designed to significantly minimize the need for external components.

## FEATURES

- Large Memory Support
- De-multiplexed Address/Data Bus
- Six Programmable Chip Selects
  - Support for Unified Memory – allows easy user modification of all code
  - External ISP Flash support for easy code download
- Dynamic Bus Sizing – each of 6 Chip Selects can be programmed for 8-bit or 16-bit bus.
- Dynamic Bus Timing – each of 6 chip selects has individual programmable bus timing.
- 32 Programmable General Purpose I/O Pins
- Four USARTs with 230.4 kbps capability
- Eight DMA Channels

## ADDITIONAL XA-H4 FEATURES (NOT AVAILABLE ON XA-H3)

- Complete DRAM controller supports up to four banks of 8 MB each
- Memory controller supports 16 MB in Unified Mode
- Memory controller supports 32 MB in Harvard Mode
- Serial ports are USARTs
  - Synchronous capability up to 1 Mbps, and include HDLC/SDLC support
  - Four Match Characters are supported on each USART in Async Mode
  - Hardware Autobaud on all four USARTs in Async Mode
  - USARTs are improved 85C30 style

## Single-chip 16-bit microcontroller

XA-H4

**Table 1. XA-H3 and XA-H4 features comparison**

Feature	XA-H3	XA-H4
Maximum External Memory (Harvard Memory Mode)	6 MB	32 MB (16 MB Code, 16 MB Data)
Maximum External Memory (Unified Memory Mode)	6 MB	16 MB
Memory Controller supports both Harvard and Unified architectures	Yes	Yes
De-multiplexed Address/Data Bus	Yes	Yes
DRAM Controller	No	Yes
DMA Channels	8	8
Dynamic Bus Sizing	Yes	Yes
Dynamic Bus Timing	Yes	Yes
Programmable Chip Selects	6	6
General Purpose IO Pins	33	33
Potential Interrupt Pins	16	16
Interrupts (programmable priority)	7 Standard SW 4 High Priority SW 9 Hardware Event	7 Standard SW 4 High Priority SW 9 Hardware Event
Two Counter/Timers plus Watchdog	Yes	Yes
Baud Rate Generators <sup>1</sup>	4	4
Serial Ports	4 UARTs	4 USARTs
Maximum Serial Data Rates	asynch to 230.4 kbps (no sync)	asynch to 230.4 kbps sync to 1 Mbps
Match Characters	No	4 asynch chars per USART
Hardware Autobaud	No	up to 230.4 kbps

**NOTE:**

1. Can be used as additional counters if not needed as BRGs.

**ORDERING INFORMATION**

ROMless Only	Temperature range °C and Package	Freq (MHz)	Package Drawing Number
H4 = PXAH40KFBE	-40 to +85°C, 100-Pin Low Profile Quad Flat Package (LQFP)	30	SOT407-1

**NOTE**

K=30 MHz, F = (-40 to +85), BE = LQFP

# Single-chip 16-bit microcontroller

# XA-H4

## PIN CONFIGURATION

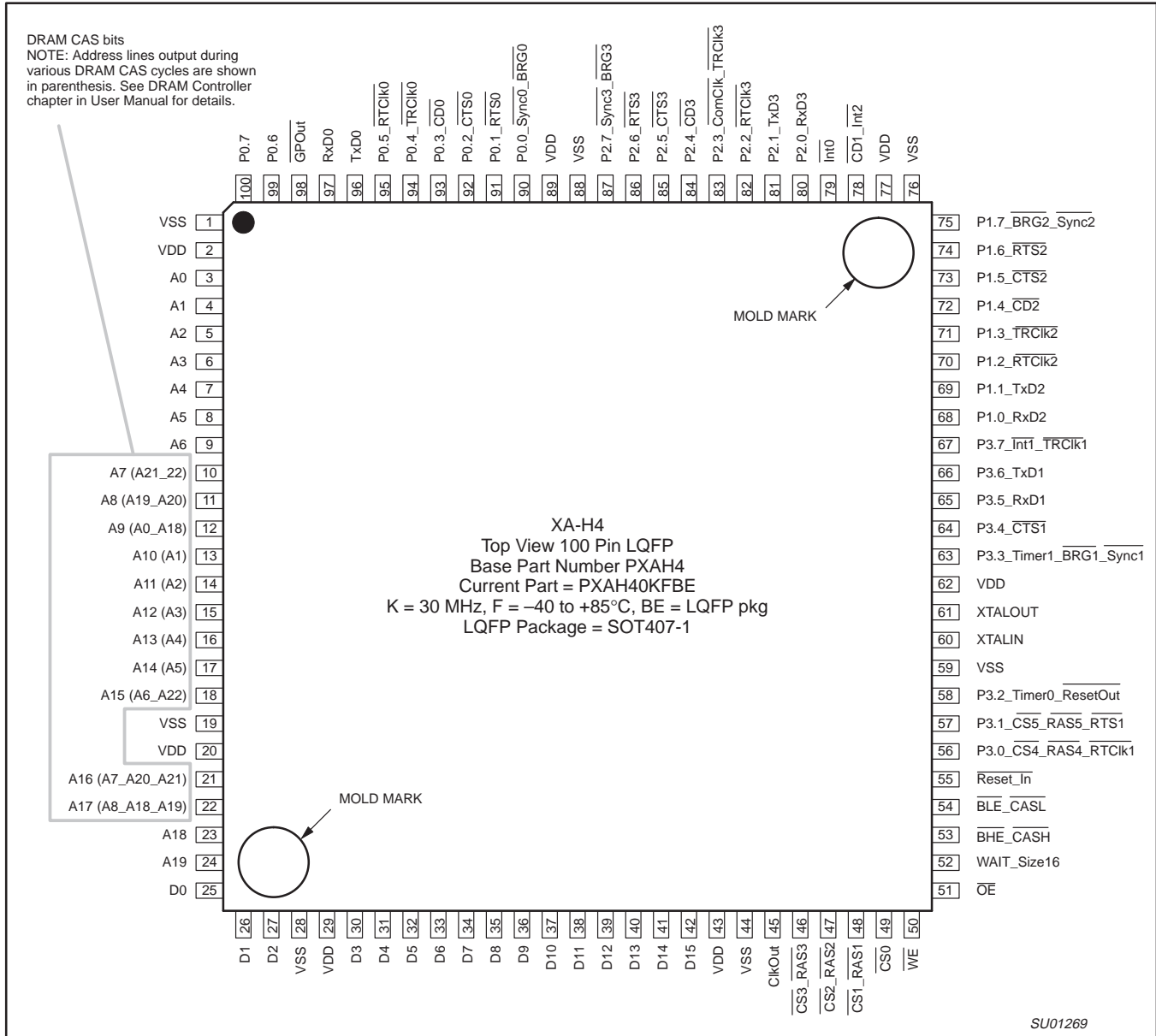

# Single-chip 16-bit microcontroller

# XA-H4

## LOGIC SYMBOL XA-H4

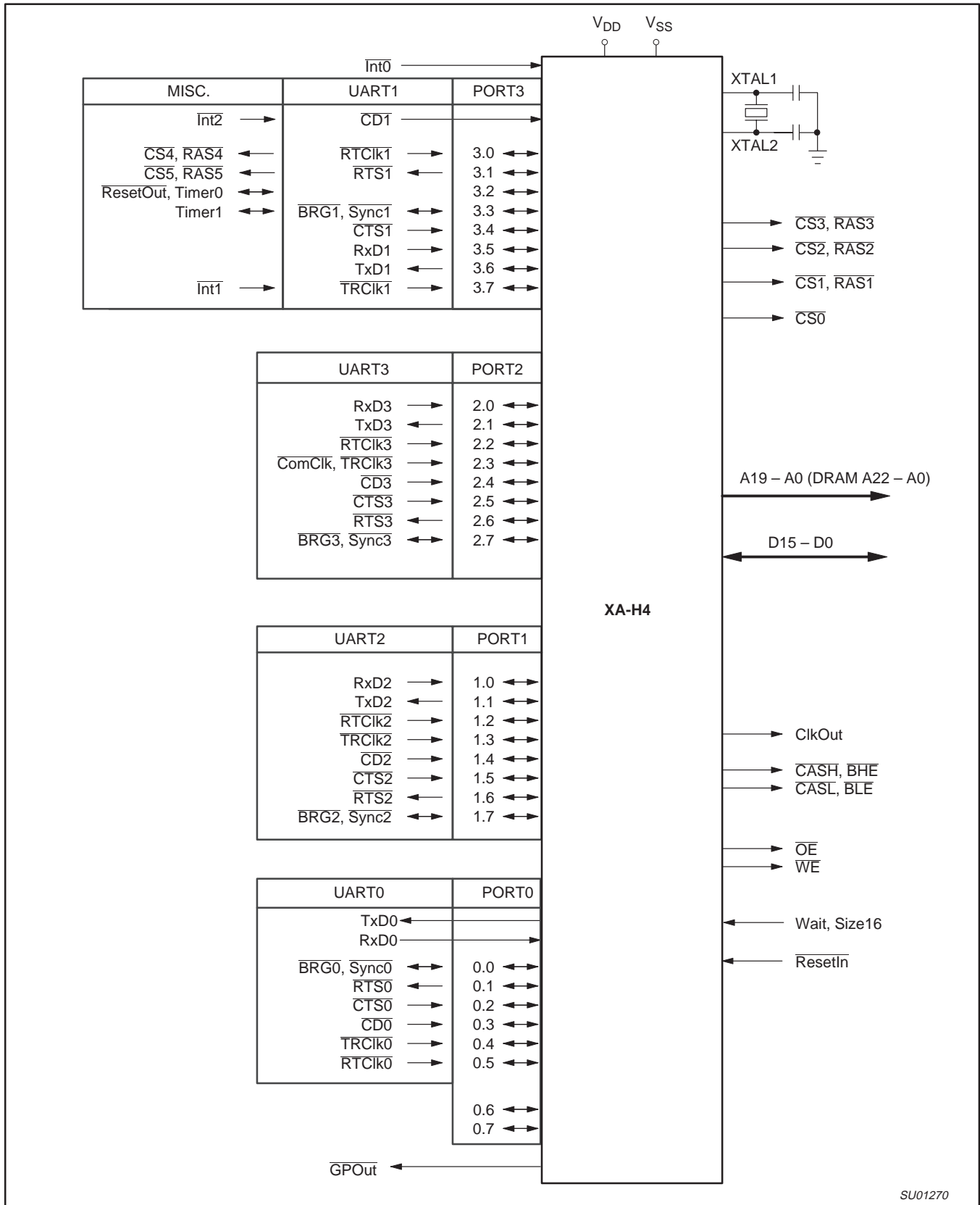

SU01270

# Single-chip 16-bit microcontroller

XA-H4

## XA-H4 BLOCK DIAGRAM

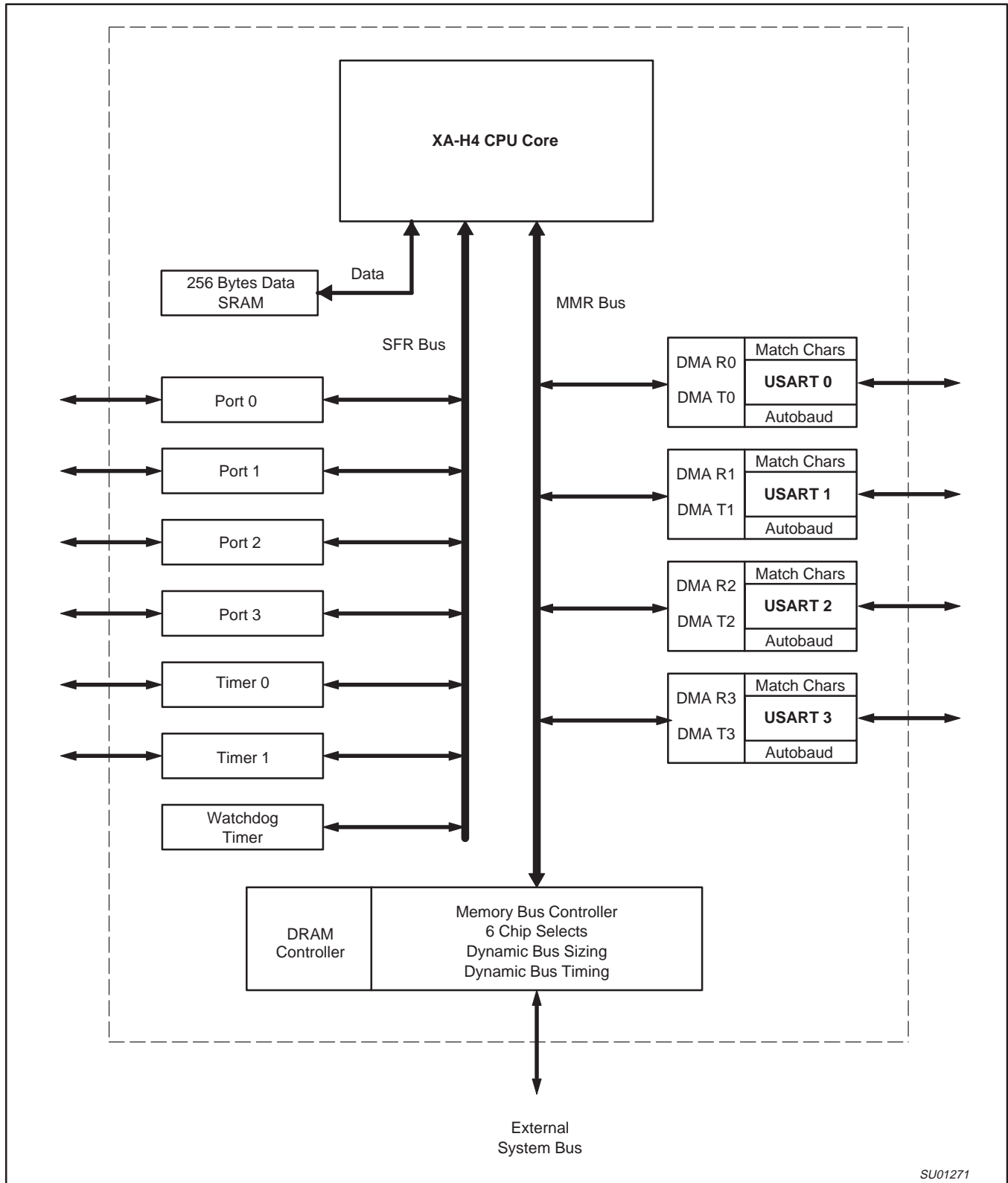

SU01271

# Single-chip 16-bit microcontroller

XA-H4

## XA-H4 MEMORY MAPS

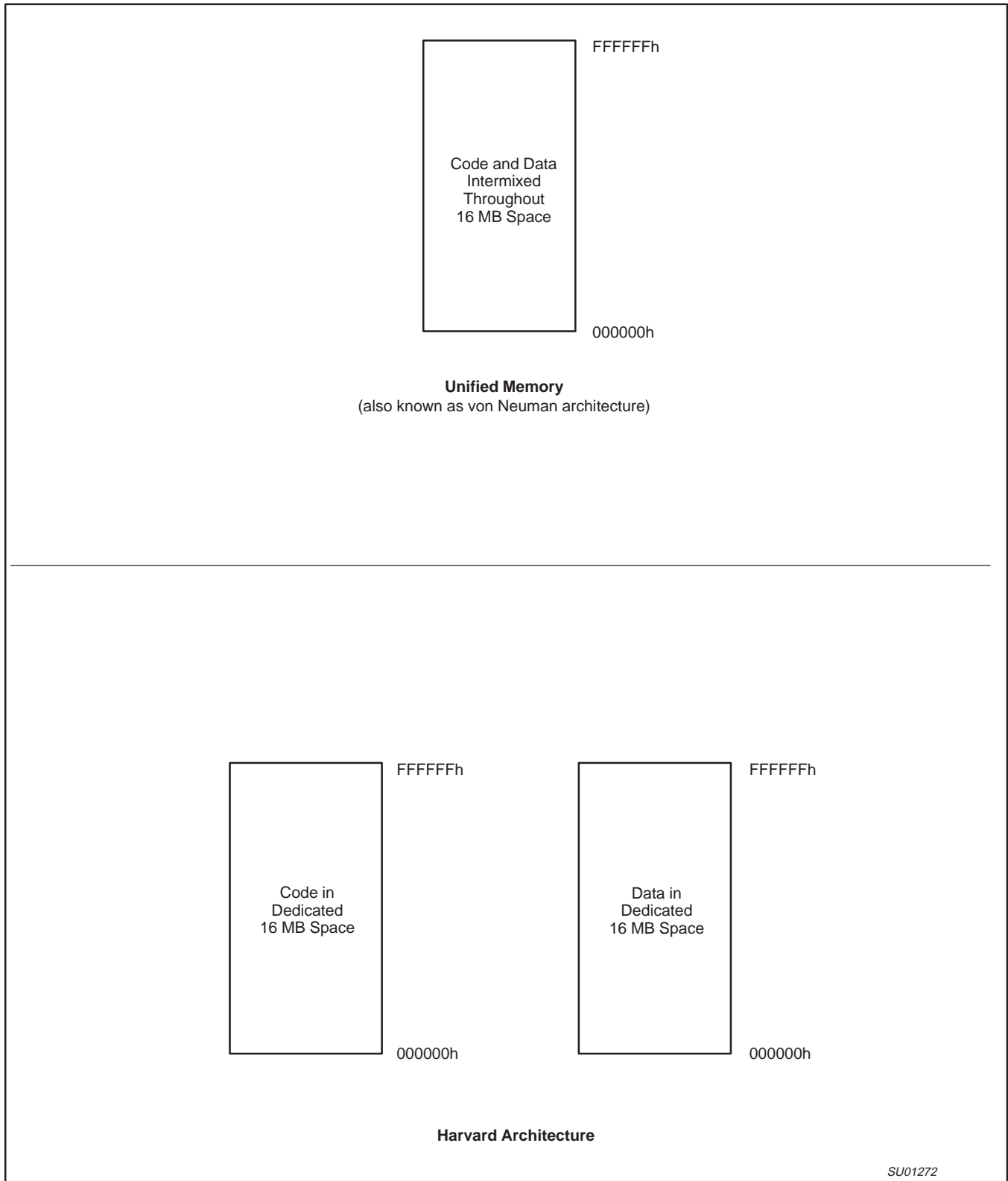

SU01272

## Single-chip 16-bit microcontroller

XA-H4

## PIN DESCRIPTIONS

Mnemonic	Lqfp Pin No.	Type	Name and Function	See Note
V <sub>SS</sub>	1, 19, 28, 44, 59, 76, 88	I	<b>Ground:</b> 0 V reference.	
V <sub>DD</sub>	2, 20, 29, 43, 62, 77, 89	I	<b>Power Supply:</b> This is the power supply voltage for normal, idle, and power down operation.	
$\overline{\text{ResetIn}}$	55	I	<b>Reset:</b> A low on this pin resets the microcontroller, causing I/O ports and peripherals to take on their default states, and the processor to begin execution at the address contained in the reset vector.	
WAIT/Size16	52	I	<b>Wait/Size16:</b> During Reset, this input determines bus size for boot device ("1" = 16-bit boot device; "0" = 8-bit.) During normal operation this is the Wait input ("1" = Wait; "0" = Proceed.)	
XTALIn	60	I	<b>Crystal 1:</b> Input to the inverting amplifier used in the oscillator circuit and input to the internal clock generator circuits.	
XTALOut	61	I	<b>Crystal 2:</b> Output from the oscillator amplifier.	
$\overline{\text{CS0}}$	49	O	<b>Chip Select 0:</b> This output provides the active low chip select to the boot device (usually ROM or Flash.) It cannot be connected to DRAM. From reset, it is enabled and mapped to an address range based at 000000h. It can be remapped by software to a higher base in the address map (see the "Memory Interface" chapter in the <i>XA-H4 User Manual</i> .)	
CS1_RAS1	48	O	<b>Chip Select 1 or RAS1:</b> Chip Selects and RAS 1 through 5 come out of reset disabled. They can be programmed to function as normal chip selects, or as RAS strobes to DRAM. CS1 can be "swapped" with CS0 (see the SWAP operation and control bit in the "Memory Controller" chapter of the <i>XA-H4 User Manual</i> .) CS1 is usually mapped to be based at 000000h after the swap, but is capable of being based anywhere in the 16 MB space.	
CS2_RAS2	47	O	<b>Chip Select 2 or RAS2:</b> Active low Chip Selects CS1 through CS5 come out of reset disabled. They can be programmed to function as normal chip selects, or as RAS strobes to DRAM. CS2 through CS5 are not used with the "SWAP" operation (see the "Memory Controller" chapter in the <i>XA-H4 User Manual</i> .) They are mappable to any region of the 16 MB address space.	
CS3_RAS3	46	O	<b>CS3 or RAS3:</b> See Chip Select 2 for description.	
See Pins 56, 57 for 2 additional Chip Selects				
$\overline{\text{WE}}$	50	O	<b>Write Enable:</b> Goes active low during all bus write cycles only.	
$\overline{\text{OE}}$	51	O	<b>Output Enable:</b> Goes active low during all bus read cycles only.	
BLE_CASL	54	O	<b>Byte Low Enable or CAS Low Byte:</b> Goes active low during all bus cycles that access D7 – D0, read or write, Generic or DRAM. Functions as CAS during DRAM cycles.	
BHE_CASH	53	O	<b>Byte High Enable or CAS High Byte:</b> Goes active low during all bus cycles that access data bus lines D15 – D8, read or write, Generic or DRAM. Functions as CAS during DRAM cycles.	
ClkOut	45	O	<b>Clock Output:</b> This pin outputs a buffered version of the internal CPU clock. The clock output may be used in conjunction with the external bus to synchronize WAIT state generators, etc. The clock output may be disabled by software. <b>WARNING:</b> The capacitive loading on this output must not exceed 40 pf.	
A19 – A0	24 – 21, 18 – 3	O	<b>Address[19:0]:</b> These address lines output A19 – A0 during (SRAM, etc.) bus cycles. DRAMS (H4 only) are connected only to pins 22, 21, 18 – 10 (pins A17 to A7; see user manual "MIF Chapter" for connecting various DRAM sizes); the appropriate address values are multiplexed onto these 11 pins for RAS and CAS during DRAM bus cycles.	
D15 – D0	42 – 30, 27 – 25	I/O	<b>Data[15:0]:</b> Bi-directional data bus, D15 – D0.	
P0.0	90	I/O	<b>P0.0_Sync0_BRG0:</b> Port 0 Bit 0, or USART0 Sync input or output, or USART0 BRG output, or USART0 TxClk output.	1
P0.1	91	I/O	<b>P0.1_RTS0:</b> Port 0 Bit 1, or USART0 RTS (Request To Send) output.	1
P0.2	92	I/O	<b>P0.2_CTS0:</b> Port 0 Bit 2, or USART0 CTS (Clear To Send) input.	1
P0.3	93	I/O	<b>P0.3_CD0:</b> Port 0 Bit 3, or USART0 Carrier Detect input.	1
P0.4	94	I/O	<b>P0.4_TRClk0:</b> Port 0 Bit 4, or USART0 TR clock input.	1, 2
P0.5	95	I/O	<b>P0.5_RTCIk0:</b> Port 0 Bit 5, or USART0 RT clock input.	1, 2
P0.6	99	I/O	<b>P0.6:</b> Port 0 Bit 6	1
P0.7	100	I/O	<b>P0.7:</b> Port 0 Bit 7	1



## Single-chip 16-bit microcontroller

XA-H4

Mnemonic	Lqfp Pin No.	Type	Name and Function	See Note
TxD0	96	O	<b>TxD0</b> : Transmit data for USART0.	
RxD0	97	I	<b>RxD0</b> : Receive data for USART0.	
$\overline{\text{GPOut}}$	98	O	<b><math>\overline{\text{GPOut}}</math> – General Purpose Output Bar</b> : Similar to GPIO, but Push/Pull and inverted output only. <b>WARNING: This output is inverted.</b> The polarity of the pin is the opposite of the bit that drives it ( $\overline{\text{GPOut}}[7]$ )	
P1.0	68	I/O	<b>P1.0_RxD2</b> : Port 1 Bit 0, or USART2 Rx Data input	
P1.1	69	I/O	<b>P1.1_TxD2</b> : Port 1 Bit 1, or USART2 Tx Data output	
P1.2	70	I/O	<b>P1.2_RTClk2</b> : Port 1 Bit 2, or USART2 RT Clock input	2
P1.3	71	I/O	<b>P1.3_TRClk2</b> : Port 1 Bit 3, or USART2 TR Clock input	2
P1.4	72	I/O	<b>P1.4_CD2</b> : Port 1 Bit 4, or USART2 Carrier Detect input	
P1.5	73	I/O	<b>P1.5_CTS2</b> : Port 1 Bit 5, or USART2 Clear To Send input	
P1.6	74	I/O	<b>P1.6_RTS2</b> : Port 1 Bit 6, or USART2 Request To Send output	
P1.7	75	I/O	<b>P1.7_BRG2_Sync2</b> : Port 1 Bit 7, or USART2 Sync input or output, or BRG output, or TxClk output (see USART clk diagrams in the user manual.)	
P2.0	80	I/O	<b>P2.0_RxD3</b> : Port 2 Bit 0, or USART3 Rx Data input	
P2.1	81	I/O	<b>P2.1_TxD3</b> : Port 2 Bit 1, or USART3 Tx Data output	
P2.2	82	I/O	<b>P2.2_RTClk3</b> : Port 2 Bit 2, or USART3 RT Clock input	2
P2.3	83	I/O	<b>P2.3_ComClk_TRClk3</b> : Port 2 Bit 3, or USART3 TR Clock input	2
P2.4	84	I/O	<b>P2.4_CD3</b> : Port 2 Bit 4, or USART3 Carrier Detect input	
P2.5	85	I/O	<b>P2.5_CTS3</b> : Port 2 Bit 5, or USART3 Clear To Send input	
P2.6	86	I/O	<b>P2.6_RTS3</b> : Port 2 Bit 6, or USART3 Request To Send output	
P2.7	87	I/O	<b>P2.7_Sync3_BRG3</b> : Port 2 Bit 7, or USART3 Sync input or output, or BRG output, or TxClk output (see USART clock diagrams in the user manual.)	
P3.0	56	I/O	<b>P3.0_CS4_RAS4_RTClk1</b> : Port 3 Bit 0, or CS4 or RAS 4 output, or USART1 RT Clock input Active low chip selects CS1 through CS5 come out of reset disabled. They can be programmed to function as normal chip selects, or as RAS strobes to DRAM. CS2 through CS5 are not used with the “SWAP” operation (see the “Memory Controller” chapter in the <i>XA-H4 User Manual</i> .) They are mappable to any region of the 16 MB address space.	2
P3.1	57	I/O	<b>P3.1_CS5_RTS1</b> : Port 3 Bit 1, or CS5 output, or USART1 Request To Send output Active low chip selects CS1 through CS5 come out of reset disabled. They can be programmed to function as normal chip selects, or as RAS strobes to DRAM. CS2 through CS5 are not used with the “SWAP” operation (see the “Memory Controller” chapter in the <i>XA-H4 User Manual</i> .) They are mappable to any region of the 16 MB address space.	
P3.2	58	I/O	<b>P3.2_Timer0_ResetOut</b> : Port 3 Bit 2, or Timer0 input or output, or ResetOut output. <b>ResetOut</b> : If the ResetOut function is selected, this pin outputs a low whenever the XA-H4 processor is reset by an <b>internal</b> source (Watchdog Reset or the RESET instruction.) <b>WARNING</b> : Unlike the other 31 GPIO pins, during power up reset, this pin can output a strongly driven low pulse. The duration of this low pulse ranges from 0 ns to 258 system clocks, starting at the time that V <sub>CC</sub> is valid. The state of the $\overline{\text{ResetIn}}$ pin does not affect this pulse. When used as GPIO, this pin can be driven low by software without resetting the XA-H4.	
P3.3	63	I/O	<b>P3.3_Timer1_BRG1_Sync1</b> : Port 3 Bit 3, or Timer1 input or output, or USART1 BRG output, or USART1 Sync input or output.	
P3.4	64	I/O	<b>P3.4_CTS1</b> : Port 3 Bit 4, or USART1 Clear To Send input	
P3.5	65	I/O	<b>P3.5_RxD1</b> : Port 3 Bit 5, or USART1 Receive Data input	
P3.6	66	I/O	<b>P3.6_TxD1</b> : Port 3 Bit 6, or USART1 Transmit Data output	
P3.7	67	I/O	<b>P3.7_Int1_TRClk1</b> : Port 3 Bit 7, or External Interrupt 1 input, or USART1 TR Clock input	2
$\overline{\text{CD1\_Int2}}$	78	I/O	<b><math>\overline{\text{CD1\_Int2}}</math></b> : USART1 Carrier Detect, or External Interrupt 2	
Int0	79	I/O	<b>External Interrupt 0</b>	

**NOTES:**

- See *XA-H4 User Guide*, “Pins Chapter,” for how to program selection of pin functions.
- RTClk input is usually used for Rx Clock if an external clock is needed, but can be used for either Rx or Tx or both. TRClk is usually used for Tx Clock, but can be used for Rx or Tx or both.

# Single-chip 16-bit microcontroller

# XA-H4

## CONTROL REGISTER OVERVIEW

There are two types of control registers in the XA-H4, these are SFRs (Special Function Registers), and MMRs (Memory Mapped Registers.) The SFR registers, with the exception of MRBL, MRBH, MICFG, BCR, BTRH, BRTL, and RSTSRC are the standard XA core registers. See **WARNINGS** about BCR, BTRH, and BRTL in Table 2.

SFRs are accessed by “direct addressing” only (see *IC25 XA User Manual* for direct addressing.) The MMRs are specific to the XA-H4

on-chip peripherals, and can be accessed by any addressing mode that can be used for off-chip data accesses. The MMRs are implemented in a relocatable block. See the “Memory Controller” chapter in the *XA-H4 User Manual* for details on how to relocate the MMRs by writing a new base address into the MRBL and MRBH (MMR Base Low and High) registers.

**Table 2. Special Function Registers (SFR)**

Name	Description	SFR Address	Bit Functions and Addresses						Reset Value		
			MSB			LSB					
BCR	Bus Configuration Reg RESERVED – see Warning	46Ah	<b>WARNING</b> – Never write to the BCR register in the XA-H4 – it is initialized to 07h, the only legal value. This is not the same as for some other XA derivatives.						07h		
BTRH	Bus Timing Reg High	469h	<b>WARNING</b> – Immediately after reset, always write BTRH = 51h, followed by writing BTRL = 40h in that order. Follow these two writes with five NOPS. This is not the same as for some other XA derivatives.						FFh		
BTRL	Bus Timing Reg Low	468h							EFh		
MRBL#	MMR Base Address Low	496h	MA15	MA14	MA13	MA12	–	–	–	MRBE	x0h
MRBH#	MMR Base Address High	497h	MA23	MA22	MA21	MA20	MA19	MA18	MA17	MA16	xx
MICFG#	ClkOut Tri-St Enable 1 = Enabled	499h	–	–	–	–	–	–	–	CLKOE	01h
CS	Code Segment	443h							00h		
DS	Data Segment	441h							00h		
ES	Extra Segment	442h							00h		
IEH*	Interrupt Enable High	427h	33F	33E	33D	33C	33B	33A	339	338	00h
			EHSWR3	EHSWR2	EHSWR1	EHSWR0	–	EAuto	ESC23	ESC01	
IEL*	Interrupt Enable Low	426h	337	336	335	334	333	332	331	330	00h
			EA	EDMAH	EDMAL	EX2	ET1	EX1	ET0	EX0	
IPA0	Interrupt Priority A0	4A0h	–	PT0		–	PX0		00h		
IPA1	Interrupt Priority A1	4A1h	–	PT1		–	PX1		00h		
IPA2	Interrupt Priority A2	4A2h	–	PDMAL		–	PX2		00h		
IPA3	Interrupt Priority A3	4A3h	Reserved			–	PDMAH		00h		
IPA4	Interrupt Priority A4	4A4h	–	PSC23		–	PSC01		00h		
IPA5	Interrupt Priority A5	4A5h	–	–		–	PAutoB		00h		
IPA6	Interrupt Priority A6	4A6h	–	PHSWR1		–	PHSWR0		00h		
IPA7	Interrupt Priority A7	4A7h	–	PHSWR3		–	PHSWR2		00h		
P0*	Port 0	430h	387	386	385	384	383	382	381	380	FFh
			38F	38E	38D	38C	38B	38A	389	388	
P1*	Port 1	431h							FFh		
			397	396	395	394	393	392	391	390	
P2*	Port 2	432h							FFh		
			39F	39E	39D	39C	39B	39A	399	398	
P3*	Port 3	433h							FFh		

# Single-chip 16-bit microcontroller

XA-H4

Name	Description	SFR Address	Bit Functions and Addresses								Reset Value
			MSB								
P0CFGA	Port 0 Configuration A	470h									5
P1CFGA	Port 1 Configuration A	471h									5
P2CFGA	Port 2 Configuration A	472h									5
P3CFGA	Port 3 Configuration A	473h									5
P0CFGB	Port 0 Configuration B	4F0h									5
P1CFGB	Port 1 Configuration B	4F1h									5
P2CFGB	Port 2 Configuration B	4F2h									5
P3CFGB	Port 3 Configuration B	4F3h									5
PCON*	Power Control Reg	404h	227	226	225	224	223	222	221	220	00h
			–	–	–	–	–	–	PD	IDL	
PSWH*	Program Status Word High	401h	20F	20E	20D	20C	20B	20A	209	208	2
			SM	TM	RS1	RS0	IM3	IM2	IM1	IM0	
PSWL*	Program Status Word Low	400h	207	206	205	204	203	202	201	200	2
			C	AC	–	–	–	V	N	Z	
PSW51*	80C51 Compatible PSW	402h	217	216	215	214	213	212	211	210	3
			C	AC	F0	RS1	RS0	V	F1	P	
RSTSRC	Reset Source Reg	463h	ROEN	–	–	–	–	R_WD	R_CMD	R_EXT	7
RTH0	Timer 0 Reload High	455h									00h
RTH1	Timer 1 Reload High	457h									00h
RTL0	Timer 0 Reload Low	454h									00h
RTL1	Timer 1 Reload Low	456h									00h
SCR	System Configuration Reg	440h	–	–	–	–	PT1	PT0	CM	PZ	00h
SSEL*	Segment Selection Reg	403h	21F	21E	21D	21C	21B	21A	219	218	00h
			ESWEN	R6SEG	R5SEG	R4SEG	R3SEG	R2SEG	R1SEG	R0SEG	
SWE	Software Interrupt Enable	47Ah	–	SWE7	SWE6	SWE5	SWE4	SWE3	SWE2	SWE1	00h
SWR*		42Ah	357	356	355	354	353	352	351	350	00h
			–	SWR7	SWR6	SWR5	SWR4	SWR3	SWR2	SWR1	
TCON*	Timer 0/1 Control	410h	287	286	285	284	283	282	281	280	00h
			TF1	TR1	TF0	TR0	IE1	IT1	IE0	IT0	
TH0	Timer 0 High	451h									00h
TH1	Timer 1 High	453h									00h
TL0	Timer 0 Low	450h									00h
TL1	Timer 1 Low	452h									00h
TMOD	Timer 0/1 Mode	45Ch	GATE	C/T	M1	M0	GATE	C/T	M1	M0	00h

# Single-chip 16-bit microcontroller

XA-H4

Name	Description	SFR Address	Bit Functions and Addresses								Reset Value
			MSB				LSB				
TSTAT*	Timer 0/1 Extended Status	411h	28F	28E	28D	28C	28B	28A	289	288	00h
			–	–	–	–	–	T1OE	–	T0OE	
WDCON*	Watchdog Control	41Fh	2FF	2FE	2FD	2FC	2FB	2FA	2F9	2F8	6
			PRE2	PRE1	PRE0	–	–	WDRUN	WDTOF	–	
WDL	Watchdog Timer Reload	45Fh									00h
WFEED1	Watchdog Feed 1	45Dh									x
WFEED2	Watchdog Feed 2	45Eh									x

**NOTES:**

- \* SFRs marked with an asterisk (\*) are bit addressable.
- # SFRs marked with a pound sign (#) are additional SFR registers specific to the XA-H3 and XA-H4.
- 1. The XA-H4 implements an 8-bit SFR bus, as stated in Chapter 8 of the *IC25 Data Handbook XA User Guide*. All SFR accesses must be 8-bit operations. Attempts to write 16 bits to an SFR will actually write only the lower 8 bits. 16-bit SFR reads will return undefined data in the upper byte.
- 2. SFR is loaded from the reset vector.
- 3. F1, F0, and P reset to “0”. All other bits are loaded from the reset vector.
- 4. Unimplemented bits in SFRs are “X” (unknown) at all times. “1”s should not be written to these bits since they may be used for other purposes in future XA derivatives. The reset value shown for these bits is “0”.
- 5. Port configurations default to quasi-bidirectional when the XA begins execution after reset. Thus all PnCFG<sub>A</sub> registers will contain FFh and PnCFG<sub>B</sub> register will contain 00h. See warning in *XA-H4 User Manual* about P3.2\_Timer0\_ResetOut pin during first 258 clocks after power up. Basically, during this period, this pin may output a strongly-driven low pulse. If the pulse does occur, it will terminate in a transition to high at a time no later than the 259th system clock after valid V<sub>CC</sub> power up.
- 6. The WDCON reset value is E6 for a Watchdog reset; E4 for all other reset causes.
- 7. The RSTSRC register reflects the cause of the last XA reset. One bit will be set to “1”, the others will be “0”. RSTSRC[7] enables the ResetOut function; “1” = Enabled, “0” = Disabled. See *XA-H4 User Manual* for details; RSTSRC[7] differs in function from most other XA derivatives.
- 8. The XA guards writes to certain bits (typically interrupt flags) that may be written by a peripheral function. This prevents loss of an interrupt or other status if a bit was written directly by a peripheral action between the read and write of an instruction that performs a read-modify-write operation. XA-H4 SFR bits that are guarded in this manner are: TF1, TF0, IE1, and IE0 (in TCON), and WDTOF (in WDCON).

## Single-chip 16-bit microcontroller

XA-H4

Table 3. Memory Mapped Registers (MMR)

MMR Name	Read/Write or Read Only	Size	Address Offset	Description	Reset Value
<b>USART0 Registers</b>					
USART0 Write Register 0	R/W	8	800h	Command register	00h
USART0 Write Register 1	R/W	8	802h	Tx/Rx Interrupt & data transfer mode	xx
USART0 Write Register 2	R/W	8	804h	Extended Features Control	xx
USART0 Write Register 3	R/W	8	806h	Receive Parameter and Control	00h
USART0 Write Register 4	R/W	8	808h	Tx/Rx miscellaneous parameters & mode	00h
USART0 Write Register 5	R/W	8	80Ah	Tx parameter and control	00h
USART0 Write Register 6 (XA-H4 only)	R/W	8	80Ch	HDLC/SDLC address field or asynch Match Character 0	00h
USART0 Write Register 7	R/W	8	80Eh	HDLC/SDLC flag or Match Character 1	xx
USART0 Write Register 8	R/W	8	810h	Transmit Data Buffer	xx
USART0 Write Register 9	R/W	8	812h	Master Interrupt control	xx
USART0 Write Register 10	R/W	8	814h	Miscellaneous Tx/Rx control register	00h
USART0 Write Register 11	R/W	8	816h	Clock Mode Control	xx
USART0 Write Register 12	R/W	8	818h	Lower Byte of Baud rate time constant	00h
USART0 Write Register 13	R/W	8	81Ah	Upper Byte of Baud rate time constant	00h
USART0 Write Register 14	R/W	8	81Ch	Miscellaneous Control bits	xx
USART0 Write Register 15	R/W	8	81Eh	External/Status interrupt control	f8h
USART0 Write Register 16	R/W	8	828h	Match Character 2 (WR16)	00h
USART0 Write Register 17	R/W	8	82Ah	Match Character 3 (WR17)	00h
USART0 Read Register 0	RO	8	820h	Tx/Rx buffer and external status	
USART0 Read Register 1	RO	8	822h	Receive condition status/residue code	
Reserved – do not write			824h		–
USART0 Read Register 3	RO	8	826h	Interrupt Pending Bits	
see WR16 and 17			828–82Ah	see WR16 and 17 above	
USART0 Read Register 6	RO	8	82Ch	SDLC byte count low register	
USART0 Read Register 7	RO	8	82Eh	SDLC byte count high and FIFO status	
USART0 Read Register 8	RO	8	830h	Receive Buffer	
Reserved			832h		
USART0 Read Register 10	RO	8	834h	Loop/clock status	
Reserved			836-83Eh		–
<b>USART1 Registers</b>					
USART1 Write Register 0	R/W	8	840h	Command register	00h
USART1 Write Register 1	R/W	8	842h	Tx/Rx Interrupt & data transfer mode	xx
USART1 Write Register 2	R/W	8	844h	Extended Features Control	xx
USART1 Write Register 3	R/W	8	846h	Receive Parameter and Control	00h
USART1 Write Register 4	R/W	8	848h	Tx/Rx miscellaneous parameters & mode	00h
USART1 Write Register 5	R/W	8	84Ah	Tx parameter and control	00h
USART1 Write Register 6	R/W	8	84Ch	HDLC/SDLC address field or Match Character 0	00h
USART1 Write Register 7	R/W	8	84Eh	HDLC/SDLC flag or async Match Character 1	xx
USART1 Write Register 8	R/W	8	850h	Transmit Data Buffer	xx
USART1 Write Register 9	R/W	8	852h	Master Interrupt control	xx
USART1 Write Register 10	R/W	8	854h	Miscellaneous Tx/Rx control register	00h
USART1 Write Register 11	R/W	8	856h	Clock Mode Control	xx
USART1 Write Register 12	R/W	8	858h	Lower Byte of Baud rate time constant	00h
USART1 Write Register 13	R/W	8	85Ah	Upper Byte of Baud rate time constant	00h

## Single-chip 16-bit microcontroller

XA-H4

MMR Name	Read/Write or Read Only	Size	Address Offset	Description	Reset Value
USART1 Write Register 14	R/W	8	85Ch	Miscellaneous Control bits	xx
USART1 Write Register 15	R/W	8	85Eh	External/Status interrupt control	f8h
USART1 Write Register 16	R/W	8	868h	Match Character 2 (WR16)	00h
USART1 Write Register 17	R/W	8	86Ah	Match Character 3 (WR17)	00h
USART1 Read Register 0	RO	8	860h	Tx/Rx buffer and external status	
USART1 Read Register 1	RO	8	862h	Receive condition status/residue code	
Reserved			864h		
USART1 Read Register 3	RO	8	866	Interrupt Pending Bits	
see WR16 and WR17		8	86Ch	see WR16 and 17 above	
USART1 Read Register 6	RO	8	86Eh	SDLC byte count low register	
USART1 Read Register 7	RO	8	86Eh	SDLC byte count high and FIFO status	
USART1 Read Register 8	RO	8	870h	Receive Buffer	
Reserved			872h		
USART1 Read Register 10	RO	8	874h	Loop/clock status	
Reserved			876-87Eh		
<b>USART2 Registers</b>					
USART2 Write Register 0	R/W	8	880h	Command register	00h
USART2 Write Register 1	R/W	8	882h	Tx/Rx Interrupt & data transfer mode	xx
USART2 Write Register 2	R/W	8	884h	Extended Features Control	xx
USART2 Write Register 3	R/W	8	886h	Receive Parameter and Control	00h
USART2 Write Register 4	R/W	8	888h	Tx/Rx miscellaneous parameters & mode	00h
USART2 Write Register 5	R/W	8	88Ah	Tx parameter and control	00h
USART2 Write Register 6	R/W	8	88Ch	HDLC/SDLC address field or Match Character 0	00h
USART2 Write Register 7	R/W	8	88Eh	HDLC/SDLC flag or Match Character 1	xx
USART2 Write Register 8	R/W	8	890h	Transmit Data Buffer	xx
USART2 Write Register 9	R/W	8	892h	Master Interrupt control	xx
USART2 Write Register 10	R/W	8	894h	Miscellaneous Tx/Rx control register	00h
USART2 Write Register 11	R/W	8	896h	Clock Mode Control	xx
USART2 Write Register 12	R/W	8	898h	Lower Byte of Baud rate time constant	00h
USART2 Write Register 13	R/W	8	89Ah	Upper Byte of Baud rate time constant	00h
USART2 Write Register 14	R/W	8	89Ch	Miscellaneous Control bits	xx
USART2 Write Register 15	R/W	8	89Eh	External/Status interrupt control	f8h
USART2 Write Register 16	R/W	8	8A8h	Match Character 2 (WR16)	00h
USART2 Write Register 17	R/W	8	8AAh	Match Character 3 (WR17)	00h
USART2 Read Register 0	RO	8	8A0h	Tx/Rx buffer and external status	
USART2 Read Register 1	RO	8	8A2h	Receive condition status	
Reserved			8A4h		
USART2 Read Register 3	RO	8	8A6h	Interrupt Pending Bits	
see WR16 and WR17		8	8ACh	see WR16 and 17 above	
USART2 Read Register 6	RO	8	8AEh	SDLC byte count low register	
USART2 Read Register 7	RO	8	8AEh	SDLC byte count high and FIFO status	
USART2 Read Register 8	RO	8	8B0h	Receive Buffer	
Reserved			8B2h		
USART2 Read Register 10	RO	8	8B4h	Loop/clock status	
Reserved			8B6-8BEh		

## Single-chip 16-bit microcontroller

XA-H4

MMR Name	Read/Write or Read Only	Size	Address Offset	Description	Reset Value
<b>USART3 Registers</b>					
USART3 Write Register 0	R/W	8	8C0h	Command register	00h
USART3 Write Register 1	R/W	8	8C2h	Tx/Rx Interrupt & data transfer mode	xx
USART3 Write Register 2	R/W	8	8C4h	Extended Features Control	xx
USART3 Write Register 3	R/W	8	8C6h	Receive Parameter and Control	00h
USART3 Write Register 4	R/W	8	8C8h	Tx/Rx miscellaneous parameters & mode	00h
USART3 Write Register 5	R/W	8	8CAh	Tx parameter and control	00h
USART3 Write Register 6	R/W	8	8CCh	HDLC/SDLC address field or Match Character 0	00h
USART3 Write Register 7	R/W	8	8CEh	HDLC/SDLC flag or Match Character 1	xx
USART3 Write Register 8	R/W	8	8D0h	Transmit Data Buffer	xx
USART3 Write Register 9	R/W	8	8D2h	Master Interrupt control	xx
USART3 Write Register 10	R/W	8	8D4h	Miscellaneous Tx/Rx control register	00h
USART3 Write Register 11	R/W	8	8D6h	Clock Mode Control	xx
USART3 Write Register 12	R/W	8	8D8h	Lower Byte of Baud rate time constant	00h
USART3 Write Register 13	R/W	8	8DAh	Upper Byte of Baud rate time constant	00h
USART3 Write Register 14	R/W	8	8DCh	Miscellaneous Control bits	xx
USART3 Write Register 15	R/W	8	8DEh	External/Status interrupt control	f8h
USART3 Write Register 16	R/W	8	8E8h	Match Character 2 (WR16)	00h
USART3 Write Register 17	R/W	8	8EAh	Match Character 3 (WR17)	00h
USART3 Read Register 0	RO	8	8E0h	Tx/Rx buffer and external status	
USART3 Read Register 1	RO	8	8E2h	Receive condition status/residue code	
Reserved			8E4h		
USART3 Read Register 3	RO	8	8E6h	Interrupt Pending Bits	
USART3 Read Register 6	RO	8	8ECh	SDLC byte count low register	
USART3 Read Register 7	RO	8	8EEh	SDLC byte count high and FIFO status	
USART3 Read Register 8	RO	8	8F0h	Receive Buffer	
Reserved			8F2h		–
USART3 Read Register 10	RO	8	8F4h	Loop/clock status	
Reserved			8F6-8FEh		
<b>Rx DMA Registers</b>					
DMA Control Register Ch.0 Rx	R/W	8	100h	Control Register	00h
FIFO Control & Status Reg Ch.0 Rx	R/W	8	101h	Control & Status Register	00h
Segment Register Ch.0 Rx	R/W	8	102h	Points to 64 k data segment	00h
Buffer Base Register Ch.0 Rx	R/W	8	104h	Wrap Reload Value for A15 – A8, A7 – A0 reloaded to zero by hardware	00h
Buffer Bound Register Ch.0 Rx	R/W	16	106h	Upper Bound (plus 1) on A15 – A0	0000h
Address Pointer Reg Ch.0 Rx	R/W	16	108h	Current Address pointer A15 – A0	0000h
Byte Count Register Ch.0 Rx	R/W	16	10Ah	Corresponds to A15 – A0 Byte Count, generates interrupt if enabled and byte count exceeded.	0000h
Data FIFO Register Ch.0 Lo Rx	R/W	16	10Ch	10Ch = Byte 0 = older, 10Dh = Byte 1 = younger	00h 00h
Data FIFO Register Ch.0 Hi Rx	R/W	16	10Eh	10Eh = Byte 2 = older, 10Fh = Byte 3 = younger	00h 00h
DMA Control Register Ch.1 Rx	R/W	8	110h	Control Register	00h
FIFO Control & Status Register Ch.1 Rx	R/W	8	111h	Control & Status Register	00h
Segment Register Ch. 1 Rx	R/W	8	112h	Points to 64 k data segment	00h



## Single-chip 16-bit microcontroller

## XA-H4

MMR Name	Read/Write or Read Only	Size	Address Offset	Description	Reset Value
Buffer Base Register Ch. 1 Rx	R/W	8	114h	Wrap Reload Value for A15 – A8, A7 – A0 reloaded to zero by hardware	00h
Buffer Bound Register Ch.1 Rx	R/W	16	116h	Upper Bound (plus 1) on A15 – A0	0000h
Address Pointer Reg Ch.1 Rx	R/W	16	118h	Current Address pointer A15 – A0	0000h
Byte Count Register Ch.1 Rx	R/W	16	11Ah	Corresponds to A15 – A0 Byte Count, generates interrupt if enabled and byte count exceeded.	0000h
Data FIFO Register Ch.1 Lo Rx	R/W	16	11Ch	11Ch = Byte 0 = older, 11Dh = Byte 1 = younger	00h 00h
Data FIFO Register Ch.1 Hi Rx	R/W	16	11Eh	11Eh = Byte 2 = older, 11Fh = Byte 3 = younger	00h 00h
DMA Control Register Ch.2 Rx	R/W	8	120h	Control Register	00h
FIFO Control & Status Register Ch.2 Rx	R/W	8	121h	Control & Status Register	00h
Segment Register Ch. 2 Rx	R/W	8	122h	Points to 64 k data segment	00h
Buffer Base Register Ch. 2 Rx	R/W	8	124h	Wrap Reload Value for A15 – A8, A7 – A0 reloaded to zero by hardware	00h
Buffer Bound Register Ch.2 Rx	R/W	16	126h	Upper Bound (plus 1) on A15 – A0	0000h
Address Pointer Reg Ch.2 Rx	R/W	16	128h	Current Address pointer A15 – A0	0000h
Byte Count Register Ch.2 Rx	R/W	16	12Ah	Corresponds to A15 – A0 Byte Count, generates interrupt if enabled and byte count exceeded.	0000h
Data FIFO Register Ch.2 Lo Rx	R/W	16	12Ch	12Ch = Byte 0 = older, 12Dh = Byte 1 = younger	00h 00h
Data FIFO Register Ch.2 Hi Rx	R/W	16	12Eh	12Eh = Byte 2 = older, 12Fh = Byte 3 = younger	00h 00h
DMA Control Register Ch.3 Rx	R/W	8	130h	Control Register	00h
FIFO Control & Status Register Ch.3 Rx	R/W	8	131h	Control & Status Register	00h
Segment Register Ch. 3 Rx	R/W	8	132h	Points to 64 k data segment	00h
Buffer Base Register Ch. 3 Rx	R/W	8	134h	Wrap Reload Value for A15 – A8, A7 – A0 reloaded to zero by hardware	00h
Buffer Bound Register Ch.3 Rx	R/W	16	136h	Upper Bound (plus 1) on A15 – A0	0000h
Address Pointer Reg Ch.3 Rx	R/W	16	138h	Current Address pointer A15 – A0	0000h
Byte Count Register Ch.3 Rx	R/W	16	13Ah	Corresponds to A15 – A0 Byte Count, generates interrupt if enabled and byte count exceeded.	0000h
Data FIFO Register Ch.3 Lo Rx	R/W	16	13Ch	13Ch = Byte 0 = older, 13Dh = Byte 1 = younger	00h 00h
Data FIFO Register Ch.3 Hi Rx	R/W	16	13Eh	13Eh = Byte 2 = older, 13Fh = Byte 3 = younger	00h 00h
<b>Tx DMA Registers</b>					
DMA Control Register Ch.0 Tx	R/W	8	140h	Control Register	00h
FIFO Control & Status Register Ch.0 Tx	R/W	8	141h	Control & Status Register	00h
Segment Register Ch. 0 Tx	R/W	8	142h	Points to 64 k data segment	00h
Buffer Base Register Ch. 0 Tx	R/W	8	144h	Wrap Reload Value for A15 – A8, A7 – A0 reloaded to zero by hardware	00h
Buffer Bound Register Ch.0 Tx	R/W	16	146h	Upper Bound (plus 1) on A15 – A0	0000h
Address Pointer Reg Ch.0 Tx	R/W	16	148h	Current Address pointer A15 – A0	0000h
Byte Count Register Ch.0 Tx	R/W	16	14Ah	Corresponds to A15 – A0 Byte Count, generates interrupt if enabled and byte count exceeded.	0000h
Data FIFO Register Ch.0 Tx	R/W	16	14Ch	14C = Byte0 = older 14D = Byte 1 = younger	0000h



## Single-chip 16-bit microcontroller

XA-H4

MMR Name	Read/Write or Read Only	Size	Address Offset	Description	Reset Value
Data FIFO Register Ch.0 Tx	R/W	16	14Eh	14E = Byte2 = older 14F = Byte3 = younger	0000h
DMA Control Register Ch.1 Tx	R/W	8	150h	Control Register	00h
FIFO Control & Status Register Ch.1 Tx	R/W	8	151h	Control & Status Register	00h
Segment Register Ch.1 Tx	R/W	8	152h	Points to 64 k data segment	00h
Buffer Base Register Ch.1 Tx	R/W	8	154h	Wrap Reload Value for A15 – A8, A7 – A0 reloaded to zero by hardware	00h
Buffer Bound Register Ch.1 Tx	R/W	16	156h	Upper Bound (plus 1) on A15 – A0	0000h
Address Pointer Reg Ch.1 Tx	R/W	16	158h	Current Address pointer A15 – A0	0000h
Byte Count Register Ch.1 Tx	R/W	16	15Ah	Corresponds to A15 – A0 Byte Count, generates interrupt if enabled and byte count exceeded.	0000h
Data FIFO Register Ch.1 Lo Tx	R/W	16	15Ch	Byte0 & 1	0000h
Data FIFO Register Ch.1 Hi Tx	R/W	16	15Eh	Byte2 & 3	0000h
DMA Control Register Ch.2 Tx	R/W	8	160h	Control Register	00h
FIFO Control & Status Register Ch.2 Tx	R/W	8	161h	Control & Status Register	00h
Segment Register Ch.2 Tx	R/W	8	162h	Points to 64 k data segment	00h
Buffer Base Register Ch.2 Tx	R/W	8	164h	Wrap Reload Value for A15 – A8, A7 – A0 reloaded to zero by hardware	00h
Buffer Bound Register Ch.2 Tx	R/W	16	166h	Upper Bound (plus 1) on A15 – A0	0000h
Address Pointer Reg Ch.2 Tx	R/W	16	168h	Current Address pointer A15 – A0	0000h
Byte Count Register Ch.2 Tx	R/W	16	16Ah	Corresponds to A15 – A0 Byte Count, generates interrupt if enabled and byte count exceeded.	0000h
Data FIFO Register Ch.2 Lo Tx	R/W	16	16Ch	Byte0 & 1	0000h
Data FIFO Register Ch.2 Hi Tx	R/W	16	16Eh	Byte2 & 3	0000h
DMA Control Register Ch.3 Tx	R/W	8	170h	Control Register	00h
FIFO Control & Status Register Ch.3 Tx	R/W	8	171h	Control & Status Register	00h
Segment Register Ch. 3 Tx	R/W	8	172h	Points to 64 k data segment	00h
Buffer Base Register Ch. 3 Tx	R/W	8	174h	Wrap Reload Value for A15 – A8, A7 – A0 reloaded to zero by hardware	00h
Buffer Bound Register Ch.3 Tx	R/W	16	176h	Upper Bound (plus 1) on A15 – A0	0000h
Address Pointer Reg Ch.3 Tx	R/W	16	178h	Current Address pointer A15 – A0	0000h
Byte Count Register Ch.3 Tx	R/W	16	17Ah	Corresponds to A15 – A0 Byte Count, generates interrupt if enabled and byte count exceeded.	0000h
Data FIFO Register Ch.3 Lo Tx	R/W	16	17Ch	Byte0 & 1	0000h
Data FIFO Register Ch.3 Hi Tx	R/W	16	17Eh	Byte2 & 3	0000h
	R/W		180-1FEh	RESERVED for future DMA	–
<b>Miscellaneous DMA Registers</b>					
Rx Character Time Out Register Ch.0	R/W	8	200h	0 value disables counter interrupt	00h
Rx Character Time Out Register Ch.1	R/W	8	202h	Same as above, for Rx1	00h
Rx Character Time Out Register Ch.2	R/W	8	204h	Same as above, for Rx2	00h
Rx Character Time Out Register Ch.3	R/W	8	206h	Same as above, for Rx3	00h
Global DMA Interrupt Register	R/W	16	210h	DMA Interrupt Flags	0000h
GPOut	R/W	8	260h	GPOut[7] drives pin 98 (GPOut) through an inverter. GPOut[6-0] are unused, and must be written with zeroes.	8xh
<b>Autobaud Registers (H4 Only)</b>					
BDAEE (H4 Only)	R/W	8	270h	Autobaud echo enable (H4 Only)	00h
BDCS (H4 Only)	R/W	8	272h	Autobaud Control and Status (H4 Only)	00h

# Single-chip 16-bit microcontroller

XA-H4

MMR Name	Read/Write or Read Only	Size	Address Offset	Description	Reset Value
<b>Memory Interface (MIF) Registers</b>					
B0CFG	R/W	8	280h	MIF Bank 0 Config	0Fh
B0AM	R/W	8	281h	MIF Bank 0 Base Address	00h
B0TMG	R/W	8	282h	MIF Bank 0 Timing Params	
B1CFG	R/W	8	284h	MIF Bank 1 Config	
B1AM	R/W	8	285h	MIF Bank 1 Base Address	
B1TMG	R/W	8	286h	MIF Bank 1 Timing Params	
B2CFG	R/W	8	288h	MIF Bank 2 Config	
B2AM	R/W	8	289h	MIF Bank 2 Base Address	
B2TMG	R/W	8	28Ah	MIF Bank 2 Timing Params	
B3CFG	R/W	8	28Ch	MIF Bank 3 Config	
B3AM	R/W	8	28Dh	MIF Bank 3 Base Address	
B3TMG	R/W	8	28Eh	MIF Bank 3 Timing Params	
B4CFG	R/W	8	290h	MIF Bank 4 Config	
B4AM	R/W	8	291h	MIF Bank 4 Base Address	
B4TMG	R/W	8	292h	MIF Bank 4 Timing Params	
B5CFG	R/W	8	294h	MIF Bank 5 Config	
B5AM	R/W	8	295h	MIF Bank 5 Base Address	
B5TMG	R/W	8	296h	MIF Bank 5 Timing Params	
MBCL	R/W	8	2BEh	MIF Memory Bank Configuration Lock Register	
RFSH	R/W	8	2BFh	MIF Refresh Control	
<b>Miscellaneous Registers</b>					
Hi-Pri Soft Ints & Pin Mux Control Reg.	R/W	16	2D0h	Control bits for Hi-Priority Soft Ints, and Pin Mux	0000h
XInt2	R/W	8	2D2h	External Interrupt 2 Control	00h

## FUNCTIONAL DESCRIPTION

The XA-H4 functions are described in the following sections. Because all blocks are thoroughly documented in either the *IC25 XA Data Handbook*, or the *XA-H4 User Manual*, only brief descriptions are given in this datasheet in conjunction with references to the appropriate document.

### XA CPU

The CPU is a 30 MHz implementation of the standard XA CPU core. See the *XA Data Handbook (IC25)* for details. The CPU core is identical to the G3 core. See the caveat in the next paragraph about the Bus Interface Unit.

### Bus Interface Unit (BIU)

This is the internal Bus, not the bus at the pins. This internal bus connects the CPU to the MIF (Memory and DRAM Controller.)

**WARNING:** Immediately after reset, always write BTRH = 51h, followed by BTRL = 40h, in that order. Once written, do not change the values in these registers. Follow these two writes with five NOPS. Never write to the BCR register. It comes out of reset initialized to 07h, which is the only value that will work.

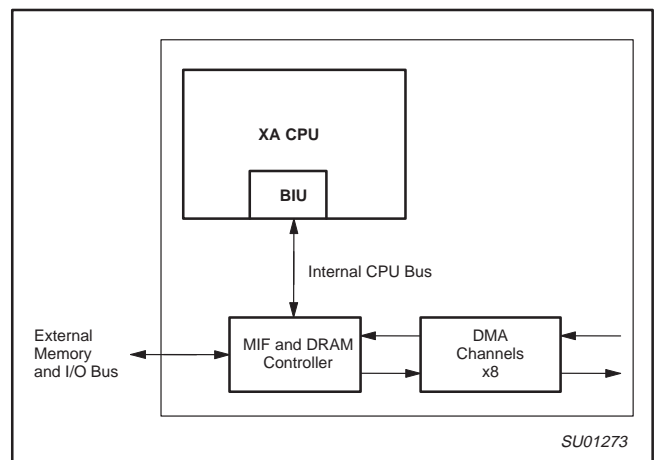

Figure 1. XA CPU core BIU (Bus Interface Unit)

### Timers 0 and 1

Timers 0 and 1 are the standard XA-G3 Timer 0 and 1. Each has an associated I/O pin and interrupt. See the XA-G3 data sheet in the *IC25 XA Data Handbook* for details. Many XA derivatives include a standard XA Timer 2 and standard UARTs. These blocks have been removed in order to provide other functions on the XA-H4. There is no Timer 2 and the UARTs have been replaced with full function USARTs.

# Single-chip 16-bit microcontroller

# XA-H4

## Watchdog Timer

This timer is a standard XA-G3 Watchdog Timer. See the G3 datasheet in IC25. Also, if you intend to use the Watchdog Timer to assert the  $\overline{\text{ResetOut}}$  pin, see “ResetOut” in the *XA-H4 User Manual*. The Watchdog Timer is enabled at reset, and must be periodically fed to prevent timeout. If the watchdog times out, it will generate an internal reset; if  $\overline{\text{ResetOut}}$  is enabled, the internal reset will generate a  $\overline{\text{ResetOut}}$  pulse (active low pulse on  $\overline{\text{ResetOut}}$  pin.)

## Reset

On the XA-H4 there are two pins associated with reset. The  $\overline{\text{ResetIn}}$  pin provides an external reset into the XA-H4. The port pin P3.2\_Timer0\_ $\overline{\text{ResetOut}}$  output can be configured as  $\overline{\text{ResetOut}}$ .

Because  $\overline{\text{ResetOut}}$  does not reflect  $\overline{\text{ResetIn}}$ , the  $\overline{\text{ResetOut}}$  pin can be tied directly back into the  $\overline{\text{ResetIn}}$  pin without other PC board logic. This configuration will make all resets (internal or external) appear to the XA as external resets. See the *XA-H4 User Manual* for a full discussion of the reset functions.

## ResetIn

The  $\overline{\text{ResetIn}}$  function is the standard XA-G3  $\overline{\text{ResetIn}}$  function. The  $\overline{\text{ResetIn}}$  signal does NOT get passed on to  $\overline{\text{ResetOut}}$ . See the *XA-H4 User Manual* for details on reset.

## ResetOut

The P3.2\_Timer0\_ $\overline{\text{ResetOut}}$  pin provides an external indication (if the  $\overline{\text{ResetOut}}$  function is enabled in the RSTSRC register) via an active low output when an internal reset occurs (internal reset is Reset instruction or Watchdog time out.) If the  $\overline{\text{ResetOut}}$  function is enabled, the  $\overline{\text{ResetOut}}$  pin will be driven low when a Watchdog reset occurs or the Reset instruction is executed. This signal may be used to inform other devices in the system that the XA-H4 has been internally reset. The  $\overline{\text{ResetIn}}$  signal does NOT get passed on to  $\overline{\text{ResetOut}}$ . When activated, the duration of the  $\overline{\text{ResetOut}}$  pulse is 256 system clocks.

**WARNING:** At power on time, from the time that power coming up is valid, the P3.2\_Timer0\_ $\overline{\text{ResetOut}}$  pin may be driven low for any period from zero nanoseconds up to 258 system clocks. This is true independently of whether  $\overline{\text{ResetIn}}$  is active or not.

## Reset Source Register

The Reset Source Identification Register (RSTSRC) indicates the cause of the most recent XA reset. The cause may have been an externally applied reset signal, execution of the RESET instruction, or a Watchdog reset. Figure 2 shows the fields in the RSTSRC register. If the  $\overline{\text{ResetOut}}$  function is tied back into the  $\overline{\text{ResetIn}}$  pin, then all resets will be external resets, and will thus appear as external resets in the reset source register. RSTSRC[7] enables the  $\overline{\text{ResetOut}}$  function; 1 = Enabled, 0 = Disabled. See *XA-H4 User Manual* for details; RSTSRC[7] differs in function from most other XA derivatives.

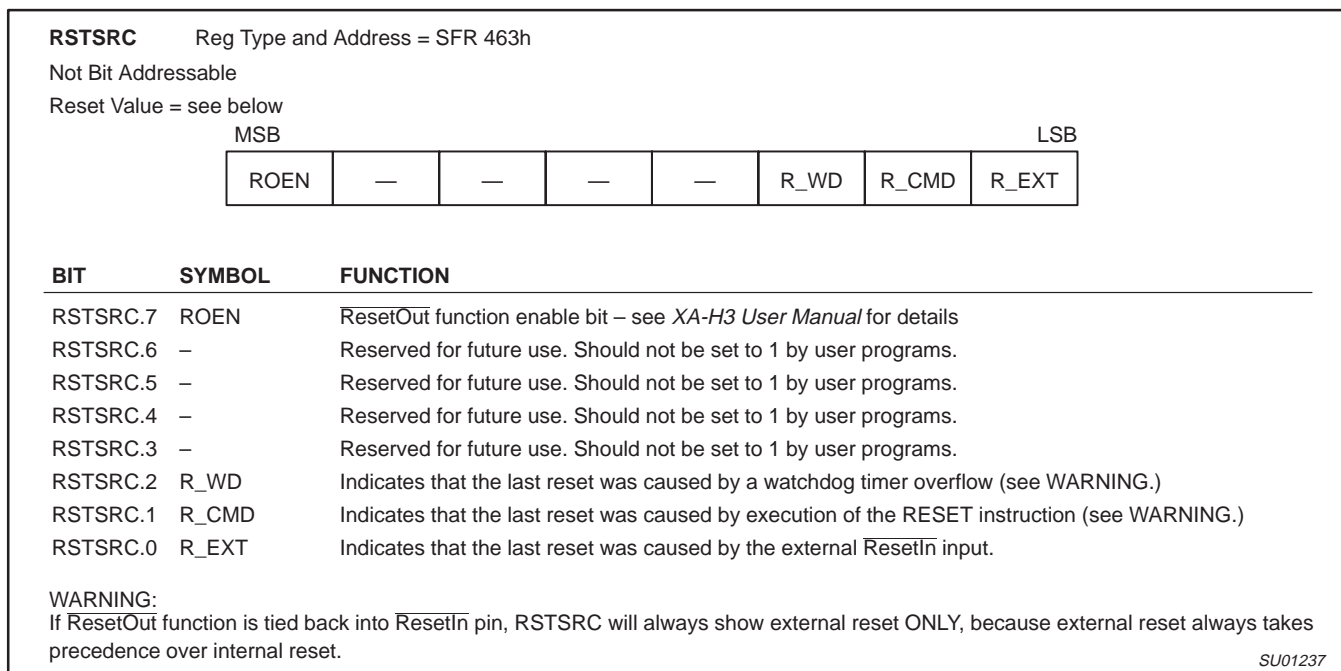

Figure 2. RSTSRC reset source register

## DRAM CONTROLLER AND MEMORY / I/O BUS INTERFACE (MIF)

In the memory or system bus interface terminology, generic bus cycles are synonymous with SRAM bus cycles, because these cycles are designed to service SRAMs, Flash, EEPROM, peripheral chips, etc. Chip select output pins function as either CS or  $\overline{\text{RAS}}$  (DRAMs and thus RAS on X-4H only) depending on whether the memory bank has been programmed as generic or DRAM.

The XA-H4 has a highly programmable memory bus interface with a complete complete onboard DRAM controller. Most DRAMs (up to 8 MB per  $\overline{\text{RAS}}$  pin), SRAMs, Flash, ROMs, and peripheral chips can be connected to this interface with zero glue chips. The bus interface provides 6 mappable chip select outputs, five of which can be programmed to function as  $\overline{\text{RAS}}$  strobes to DRAM.  $\overline{\text{CAS}}$  generation, proper address multiplexing for a wide range of DRAM sizes, and refresh are all generated onboard. The bus timing for each individual

# Single-chip 16-bit microcontroller

XA-H4

memory bank or peripheral can be programmed to accommodate slow or fast devices.

Each memory bank and its associated  $\overline{\text{RAS}}$  (chip select in DRAM mode) output, can be programmed to access up to an 8 MB mappable address space in either EDO or FPM DRAM modes (up to a total of 32 MB of DRAM. **WARNING:** Future XA-H4 derivatives may not support separate code and data spaces.)

Each memory bank and associated chip select programmed for "generic" (SRAM, Flash, ROM, peripheral chips, etc.) is capable of supporting a 1 MB address space.

The Memory Interface can be programmed to support both Intel style and 68000 bus style SRAMs and peripherals.

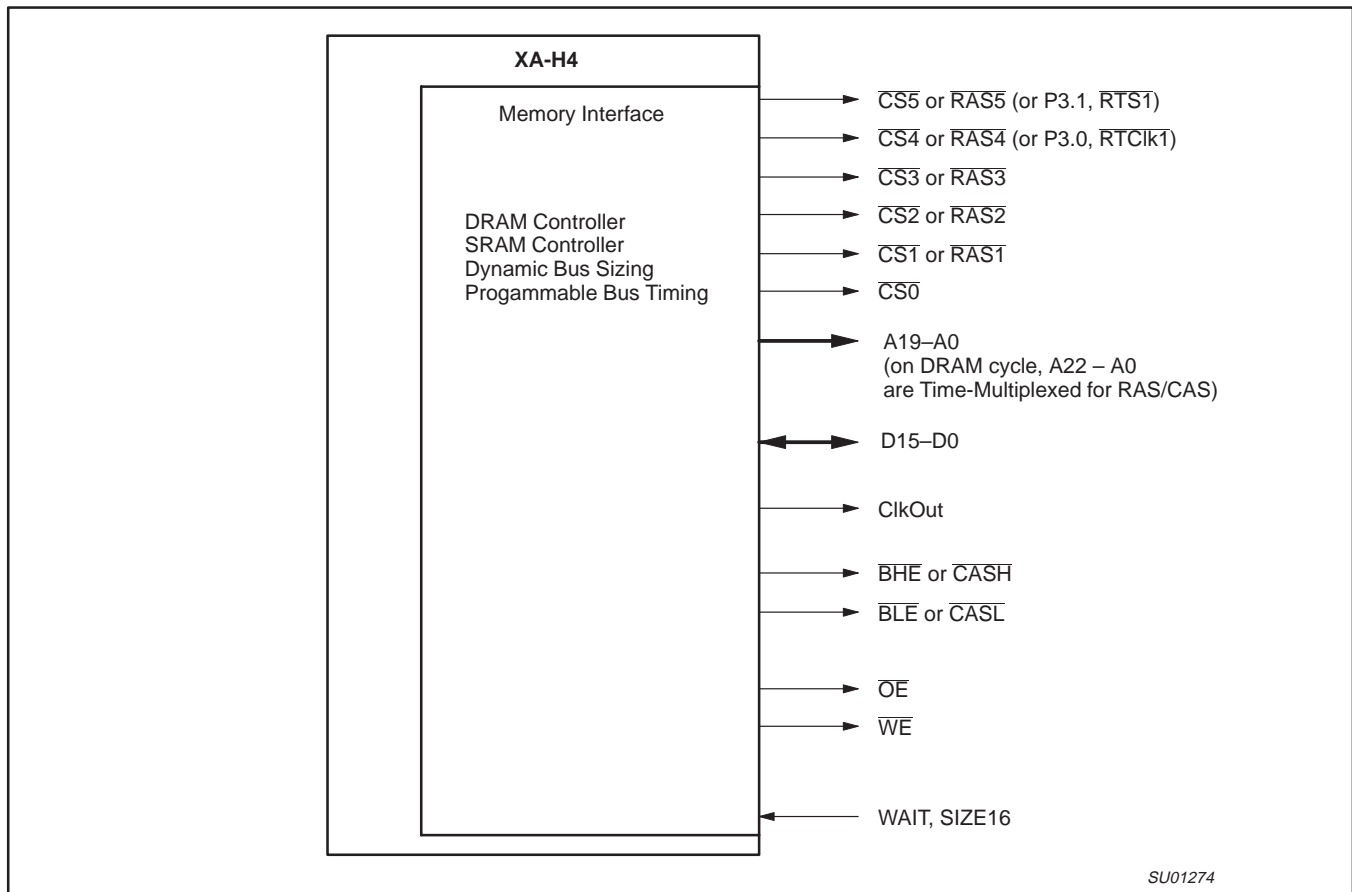

Figure 3. Memory bus interface signal pins

### Bus Interface Pins

For the following discussion, see Figure 3.

### Chip Select Pins

There are six chip select pins ( $\overline{\text{CS5}}$  –  $\overline{\text{CS0}}$ ) mapped to six sets of bank control registers. The following attributes are individually programmable for each bank and associated chip select (or  $\overline{\text{RAS}}$ , if DRAM): bank on/off, address range, external device access time, detailed bus strobe sequence, DRAM cycle or generic bus cycle, DRAM size if DRAM, and bus width. Pin  $\overline{\text{CS0}}$  is always generic in order to service the boot device, thus  $\overline{\text{CS0}}$  cannot be connected to DRAM.

**WARNING:** On the external bus, ALL XA-H4 reads are 16-bit Reads. If the CPU instruction only specifies 8-bits, then the CPU uses the appropriate byte, and discards the extra byte. Thus "8-Bit Reads" and "16-Bit Reads" appear to be identical on the bus. **On an 8-bit bus, this will appear as two consecutive 8-bit reads** even though the CPU instruction specified a byte read.

Some 8-bit I/O devices (especially FIFOs) cannot operate correctly with 2 bytes being read for a 1 Byte Read. The most common (and least expensive) solution is to operate these 8-bit devices on a 16-bit bus, and access them in software on all odd byte (or all even byte) boundaries. An added benefit of this technique is that byte Reads are faster than on an 8-bit bus, because only 1 word is fetched (a single Read) instead of 2 consecutive bytes.

# Single-chip 16-bit microcontroller

XA-H4

## Clock Output

The ClkOut pin allows easier external bus interfacing in some situations. This output reflects the XTALIn clock input to the XA (referred to internally as CClk or System Clock), but is delayed to match the external bus outputs and strobes. The default is for

ClkOut to be output enabled at reset, but it may be turned off (tri-state disabled) by software via the MICFG MMR.

**WARNING:** The capacitive loading on this output must not exceed 40 pf.

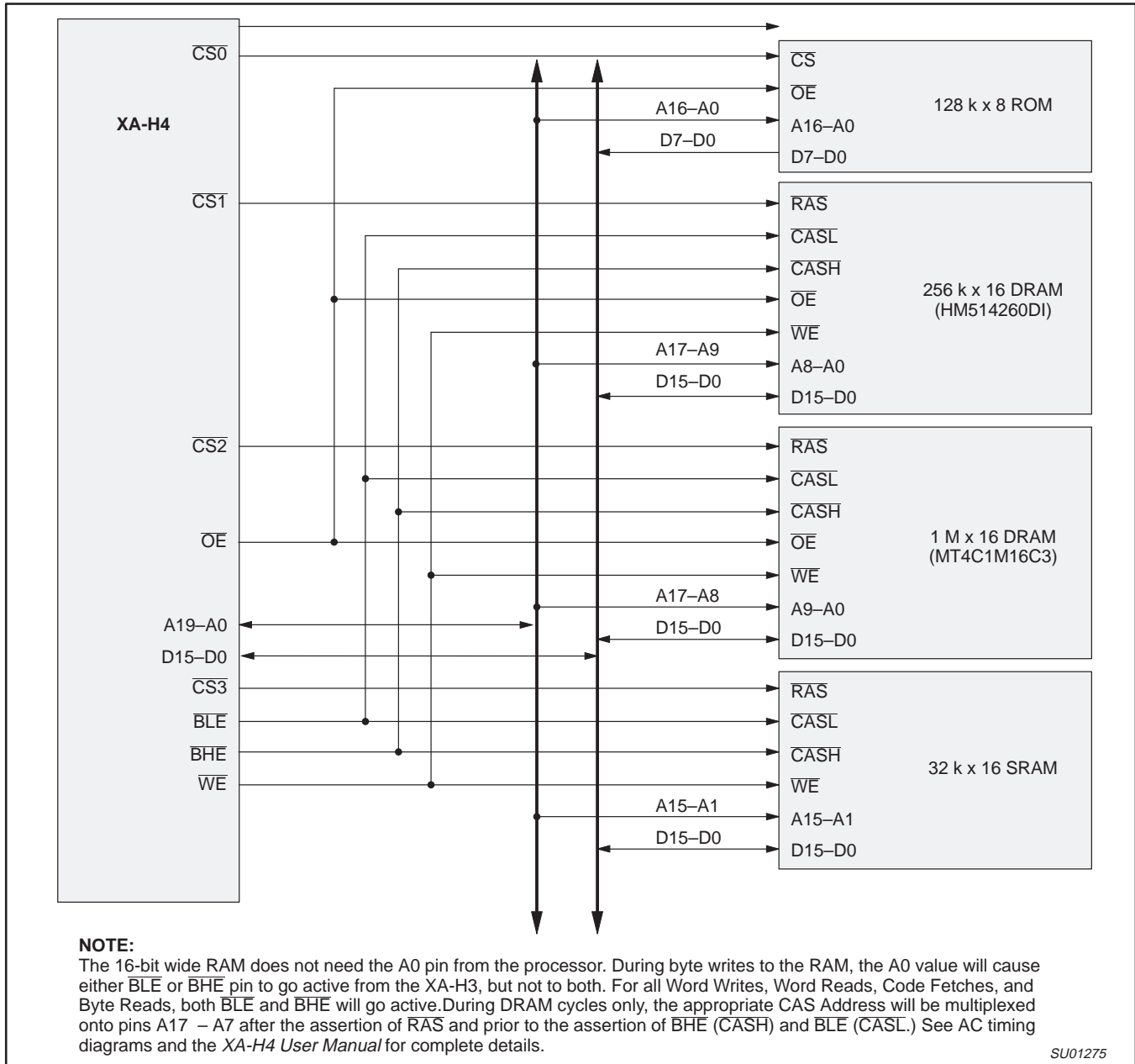

Figure 4. Typical system bus configuration

# Single-chip 16-bit microcontroller

XA-H4

**Table 4. Memory interface control registers**

	Register Name	Reg Type	Description
MRBH	“MMR Base Address” High	SFR 8 bits	This SFR is used to relocate the MMRs. It contains address bits a23 – a16 of the base address for the 4 kB Memory Mapped Register space. See the <i>XA-H4 User Manual</i> for using this SFR to relocate the MMRs.
MRBL	“MMR Base Address” Low	SFR 8 bits	Contains address bits a15 – a12 of the base address for the 4 kB Memory Mapped Register space.
MICFG	MIF Configuration	MMR 8 bits	Contains the ClkOut Enable bit.
MBCL	Memory Bank Configuration Lock	MMR 8 bits	Contains the bits for locking and unlocking the BiCFG Registers.
BiCFG	Bank i Configuration	MMR 8 bits	Contains the size, type, bus width, and enable bits for Memory Bank i.
BiAM	Bank i Base Address/DRAM Address Multiplexer Control	MMR 8 bits	Contains the base address bits and DRAM address multiplex control bits for Memory Bank i.
BiTMG	Bank i Timing	MMR 8 bits	Contains the timing control bits for Memory Bank i.
RFSH	Refresh Timing	MMR 8 bits	Contains the refresh time constant and DRAM Refresh Timer enable bit.

## EIGHT CHANNEL DMA CONTROLLER

The XA-H3/H4 has eight DMA channels; one Rx DMA channel dedicated to each USART Receive (Rx) channel, and one Tx DMA channel dedicated to each USART Transmit (Tx) channel. All DMA channels are optimized to support memory efficient circular data buffers in external memory. All DMA channels can also support traditional linear data buffers.

### Transmit DMA Channel Modes

The four Tx channels have four DMA modes specifically designed for various applications of the attached USARTs. These modes are summarized in Table 5. Full details for all DMA functions can be found in the DMA chapter of the *XA-H4 User Manual*.

**Table 5. Tx DMA modes summary**

Mode	Byte Count Source	Maskable Interrupt	Description
Non-SDLC/HDLC Tx Chaining	Header in memory	On stop	DMA channel picks up header from memory at the end of transmission. If the byte count in the header is greater than zero, then DMA transmits the number of bytes specified in the byte count. If byte count equals 0, then a maskable interrupt is generated. This process repeats until the byte count in the data header is zero. See <i>XA-H4 User Manual</i> for details.
SDLC/HDLC Tx Chaining	Header in memory	End of packet (not end of fragment)	Same as above, except DMA header distinguishes between fragment of packet and full pack. See <i>XA-H4 User Manual</i> for details.
Stop on TC	Processor loads Byte Count Register (for each fragment)	Byte count completed (Tx DMA stops)	Processor loads byte count into DMA. DMA sends that number of bytes, generates maskable interrupt, and stops.
Periodic Interrupt	Processor loads Byte Count Register (only once)	When Byte Counter reaches zero and is reloaded by DMA hardware from the byte count register.	DMA runs until commanded to stop by processor. Every time byte counter rolls over, a new maskable interrupt is generated.

# Single-chip 16-bit microcontroller

# XA-H4

## Receive DMA Channel Modes

The Rx DMA channels have four DMA modes specifically designed for various applications of the attached USARTs. These modes are

summarized in Table 6. For full details on implementation and use, see the *XA-H4 User Manual*.

**Table 6. Rx DMA modes summary**

Mode	Byte Count Source	Maskable Interrupt	Description
SDLC/HDLC Rx Chaining	DMA stores byte count in header in memory with data packet.	At end of received packet	When a complete or aborted SDLC/HDLC packet has been received, the packet byte count and status information are stored in memory with the packet. A maskable interrupt is generated.
Periodic Interrupt	Loaded by processor into DMA, used only to determine the number of bytes between interrupts. Processor can infer the byte count from the DMA address pointer.	When Byte Counter reaches zero and is reloaded by DMA hardware from the byte count register.	The DMA channel runs until commanded to stop by the processor. It generates a maskable interrupt once per <i>n</i> bytes, where <i>n</i> is the number written once into the byte count register by the processor, thus an interrupt is generated once every <i>n</i> received bytes.
Asynchronous Character Time Out	Byte Count can be calculated by software from the DMA address pointer.	If no character is received within a specified time out period, then interrupt.	Processor specifies time out period between incoming characters. If no character is received within that time, a maskable interrupt is generated.
Asynchronous Character Match	Byte Count can be calculated by software from the DMA address pointer.	When matched character is stored in memory.	There are four match registers, each incoming character is received within that time, a maskable interrupt is generated. When a matched character is stored in memory by DMA, a maskable interrupt is generated.

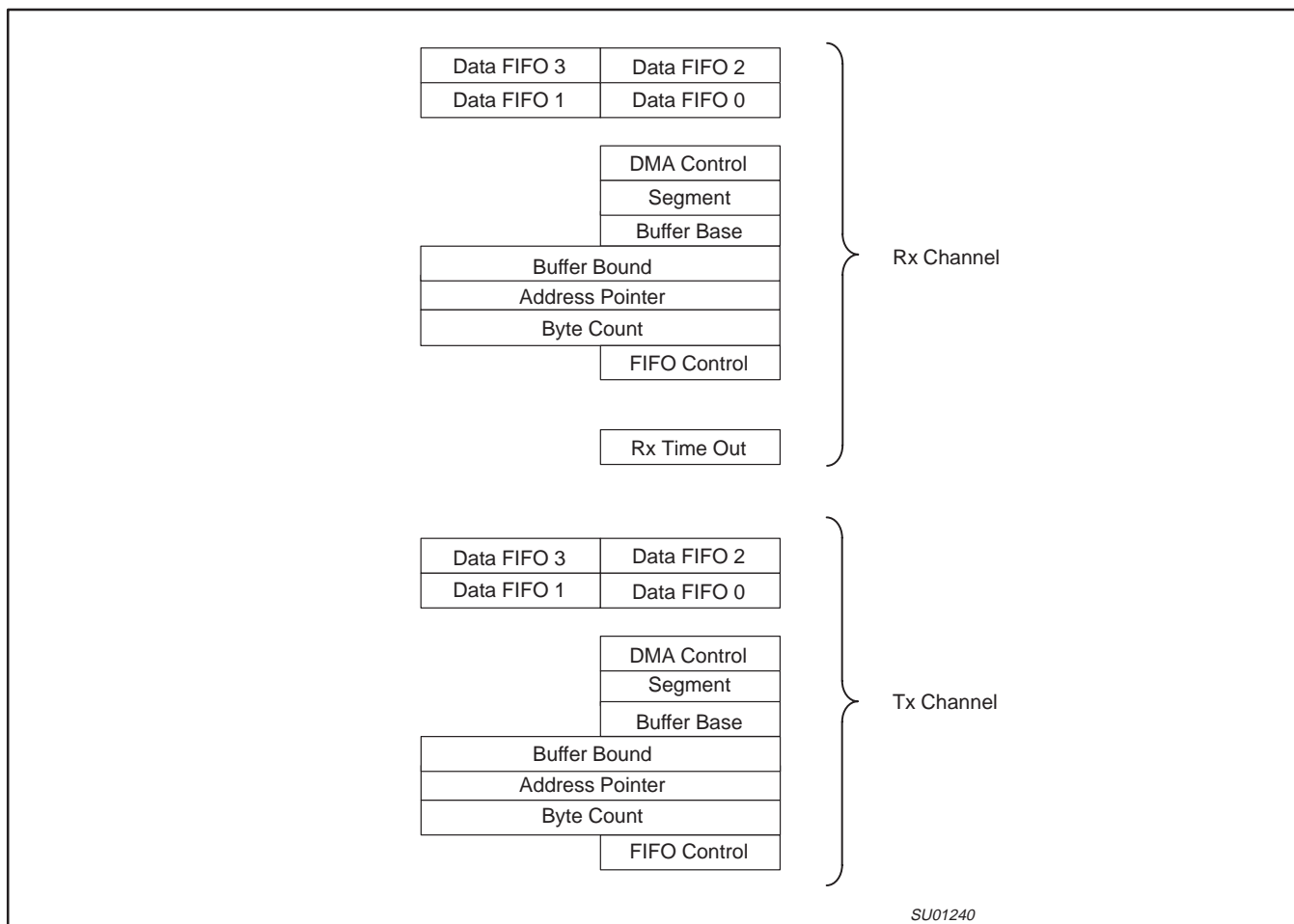

SU01240

**Figure 5. Rx and Tx DMA Registers**



# Single-chip 16-bit microcontroller

XA-H4

## DMA Registers

In addition to the 16-bit Global DMA Interrupt Register (which is shared by all eight DMA channels), each DMA channel has seven control registers and a four-byte Data FIFO. The four Rx DMA channels have one additional register, the Rx Character Time Out Register. All DMA registers can be read and written in Memory Mapped Register (MMR) space. These registers are summarized below.

- Global DMA Interrupt Register (not shown in figure): All DMA interrupt flags are in this register .
- DMA Control Register: Contains the master mode select and interrupt enable bits for the channel.
- Segment Register: Holds A23–A16 (the current segment) of the 24-bit data buffer address.
- Buffer Base Register: Holds a pointer (A15–A8) to the lowest byte in the memory buffer.
- Buffer Bound Register: Points to the first out-of-bounds address above a circular buffer.
- Address Pointer Register: Points to a single byte or word in the data buffer in memory. The 24-bit DMA address is formed by concatenating the contents of the Segment Register [A23–A16] with the contents of the Address Pointer Register [A15–A0].
- Byte Count Register: Holds the initial number of bytes to be transferred. In Tx Chaining mode, this register is not used because the byte count is brought into the byte counter from buffer headers in memory.
- FIFO Control & Status Register: Holds the queuing order and full/empty status for the Data FIFO Registers.
- Data FIFO Registers: A four-byte data FIFO buffer internal to the DMA channel.
- Rx Char Time Out Register (RxCTOR, Rx DMA channels only): Holds the initial value for an 8-bit character timeout countdown timer which can generate an interrupt.

## Four USARTS

- Asynchronous features:
  - Asynchronous transfers up to 921.6 kbps
  - Can monitor input stream for up to four match characters per receiver (H4 only)
  - 5, 6, 7, or 8 data bits per character
  - 1, 1.5, or 2 Stop bits per character
  - Even or Odd parity generate and check
  - Parity, Rx Overrun, and Framing Error detection
  - Break detection
  - Supports hardware Autobaud detection and response up to 921.6 kbps.
- SDLC/HDLC features:
  - Automatic Flag and Abort Character generation and recognition
  - Automatic CRC generation and checking (can be disabled for “pass-thru”)
  - Automatic zero-bit insertion and stripping
  - Automatic partial byte residue code generation
  - 14-bit Packet byte count stored in memory with received packet by DMA

- Synchronous character-oriented protocol features (XA-H4 only):
  - Automatic CRC generation and checking
  - External Sync option
- Data encoding/decoding options:
  - FM0 (Biphase Space)
  - FM1 (Biphase Mark)
  - NRZ
  - NRZI
- Programmable Baud Rate Generator
- Auto Echo and Local Loopback modes

## Autobaud Detectors

Each USART has its own Autobaud detector, capable of baud rate detection up to 921.6 kbaud. The detectors can be programmed to automatically echo the industry standard autobaud sequences. They can be programmed to update the necessary control registers in the USARTs and turn on the receiver, which in turn will automatically initiate DMA into memory of received data. Thus, once the baud rate is determined, reception begins without intervention from the processor. When the baud rate is detected, a maskable interrupt is sent to the processor. See the “Autobaud” chapter in the *XA-H4 User Manual* for details.

## I/O Port Output Configuration

Port input/output configurations are the same as standard XA ports: open drain, quasi-bidirectional, push-pull, and off (off means tri-state Hi-Z, and allows the pin to be used as an input. **WARNING:** At power on time, from the time that power coming up is valid, the P3.2\_Timer0\_ResetOut pin may be driven low for any period from zero nanoseconds up to 258 system clocks. This is true independently of whether ResetIn is active or not.

## Power Reduction Modes

The XA-H4 supports Idle and Power Down modes of power reduction. The idle mode leaves most peripherals running in order to allow them to activate the processor when an interrupt is generated. The power down mode stops the oscillator in order to absolutely minimize power. The processor can be made to exit power down mode via a reset or one of the external interrupt inputs (INT0 or INT1). This will occur if the interrupt is enabled and its priority is higher than that defined by IM3 through IM0. In power down mode, the power supply voltage may be reduced to the RAM keep-alive voltage  $V_{RAM}$ . This retains the RAM, register, and SFR contents at the point where power down mode was entered. **WARNING:**  $V_{DD}$  must be raised to within the operating range before power down mode is exited.

## Interrupts

In the XA architecture, all exceptions, including Reset, are handled in the same general exception structure. The highest priority exception is, of course, Reset, and is non-maskable. All exceptions are vectored through the Exception Vector Table in low memory. Coming out of Reset, these vectors must be stored in non-volatile memory based at location 000000. Later in the boot sequence, DRAM or SRAM can be mapped into this address space if desired. There is a feature in the XA-H4 Memory Controller called “Bank Swap” that supports replacing the ROM vector table and other low memory with RAM. See the *XA-H4 User Manual* for details.



# Single-chip 16-bit microcontroller

XA-H4

The XA-H4 has a standard XA CPU Interrupt Controller, implemented with 15 Maskable Event Interrupts. Event Interrupts are defined as maskable interrupts usually generated by hardware events. However, in the XA-H4, 4 of the 15 Event Interrupts are generated by software writing directly to the interrupt flag bit. These 4 interrupts are referred to as "High Priority Software Interrupts."

See the *IC25 XA Data Handbook* for a full explanation of the exception structure, including event interrupts, of the XA CPU. Because the High Priority Software Interrupts are not implemented on all XA derivatives, they are explained in the *XA-H4 User Manual*.

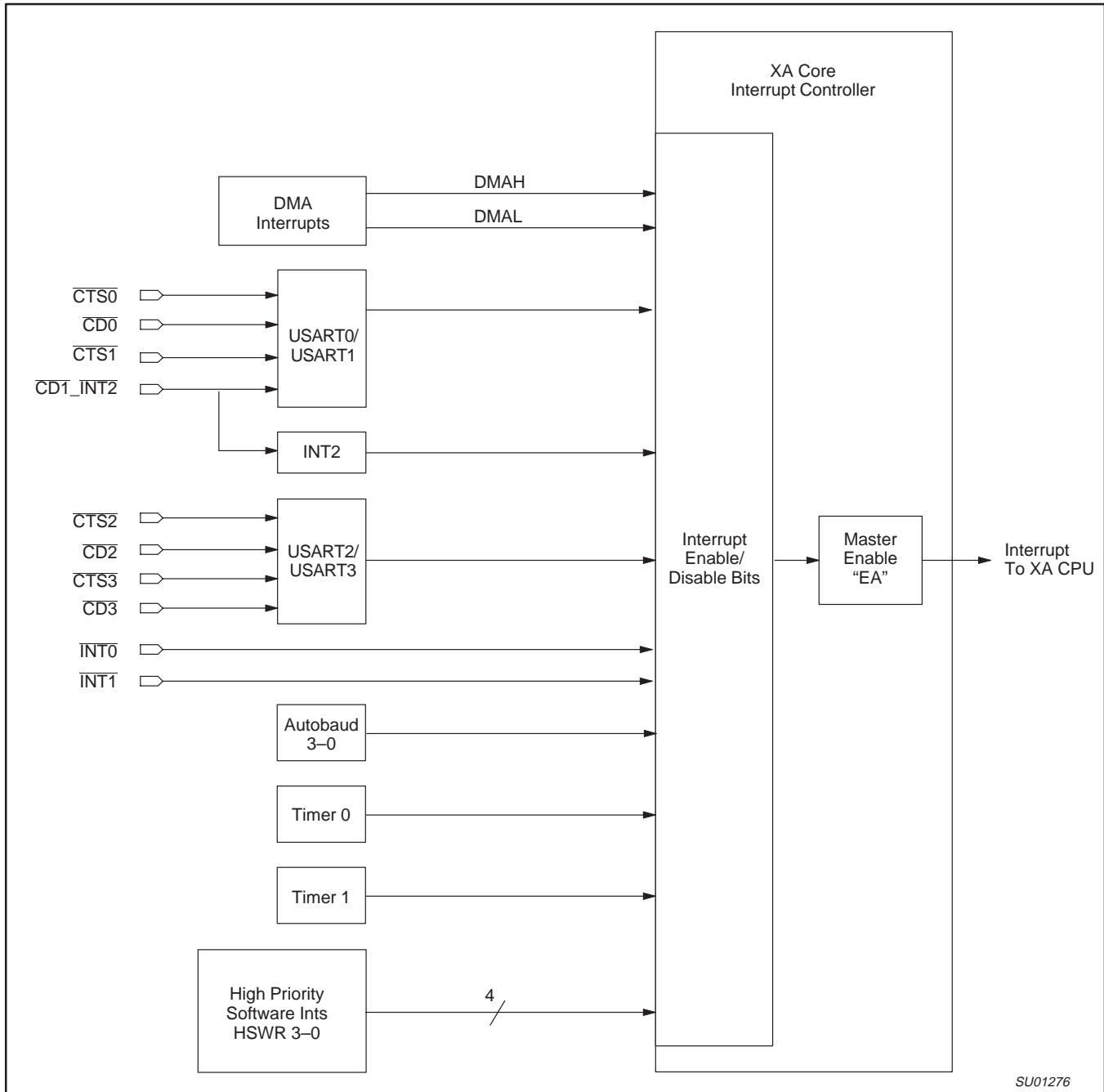

Figure 6. XA-H4 Interrupt Structure Overview

Single-chip 16-bit microcontroller

XA-H4

**Table 7. USART0 Interrupts (Interrupt structure is the same, except for bit locations, for all 4 USARTs)**

Potential USART0 Interrupt	Individual Enable Bit MMR Hex Offset	Source Bit MMR Hex Offset	Group Enable Bit(S) MMR Hex Offset	Group Flag Bit MMR Hex Offset	Master Enable Bit MMR Hex Offset
Rx Character Available	–	RR0[0] 820[0]	WR1[4:3] 802[4:3]	Even Channel Rx IP RR3[5] 826[5]	USART0/1 Master Interrupt Enable WR9[3] 812[3]
SDLC EOF (XA-H4 Only)	–	RR1[7] 822[7]			
CRC/Framing Error	–	RR1[6] 822[6]			
Rx Overrun	–	RR1[5] 822[5]			
Parity Error	WR1[2] 802[2]	RR1[4] 822[4]			
Tx Buffer Empty	See WR1[1]	RR0[2] 820[2]	Tx Interrupt Enable WR1[1] 802[1]	Even Channel Tx IP RR3[4] 826[4]	
Break/Abort	Break/ Abort IE WR15[7] 81E[7]	RR0[7] 820[7]	Master External/Status Interrupt Enable WR1[0] 802[0]	Even Channel External/Status IP RR3[3] 826[3]	
Tx Underrun/EOM	Tx Underrun/EOM IE WR15[6] 81E[6]	RR0[6] 820[6]			
CTS	CTS IE WR15[5] 81E[5]	RR0[5] 820[5]			
SYNC/HUNT (XA-H4 Only)	SYNC/ HUNT IE WR15[4] 81E[4]	RR0[4] 822[4]			
DCD	DCD IE WR15[3] 81E[3]	RR0[3] 820[3]			
Zero Count	Zero Count IE WR15[1] 81E[1]	RR0[1] 820[1]			

**EXCEPTION/TRAPS PRECEDENCE**

Description	Vector Address	Arbitration Ranking
Reset (h/w, watchdog, s/w)	0000–0003	0 (High)
Break Point	0004–0007	1
Trace	0008–000B	1
Stack Overflow	000C–000F	1
Divide by 0	0010–0013	1
User RETI	0014–0017	1
TRAP 0–15 (software)	0040–007F	1

## Single-chip 16-bit microcontroller

XA-H4

## EVENT INTERRUPTS

Description Event Interrupt Source	Flag Bit	Interrupt Vector Address	Enable Bit (SFR)	Priority Register Bit Field (SFR)	Arb. Rank
High Priority Software Interrupt 3	H3WR3 MMR 2D0[15]	00BF–00BC	E3HWR3 427[7] 33F	P3HWR3 4A7[6:4]	17
High Priority Software Interrupt 2	H2WR2 MMR 2D0[14]	00BB–00B8	E2HWR2 427[6] 33E	P2HWR2 4A7[2:0]	16
High Priority Software Interrupt 1	H1WR1 MMR 2D0[13]	00B7–00B4	E1HWR1 427[5] 33D	P1HWR1 4A6[6:4]	15
High Priority Software Interrupt 0	H0WR0 MMR 2D0[12]	00B3–00B0	E0HWR0 427[4] 33C	P0HWR0 4A6[2:0]	14
USART "USART2/3" Interrupt	multiple OR from USART2 & USART3	00A7–00A4	ESC23 427[1] 339	PSC23 4A4[6:4]	11
USART "USART0/1" Interrupt	multiple OR from USART0 & USART1	00A3–00A0	ESC01 427[0] 338	PSC01 4A4[2:0]	10
DMA "DMAH" Interrupt	multiple OR from DMA	009B–0098	EDMAH 426[6] 336	PDMAH 4A3[2:0]	8
DMA "DMAL" Interrupt	multiple OR from DMA	0097–0094	EDMAL 426[5] 335	PDMAL 4A2[6:4]	7
External Interrupt 2 (INT2)	IE2 MMR 2D2[0]	0093–0090	EX2 426[4] 334	PX2 4A2[2:0]	6
Timer 1	TF1 SFR 410[7] 287	008F–008C	ET1 426[3] 333	PT1 4A1[6:4]	5
External Interrupt 1 (INT1)	IE1 SFR 410[3] 283	008B–0088	EX1 426[2] 332	PX1 4A1[2:0]	4
Timer 0	TF0 SFR 410[5] 285	0087–0084	ET0 426[1] 331	PT0 4A0[6:4]	3
External Interrupt 0 (INT0)	IE0 SFR 410[1]	0083–0080	EX0 426[0] 330	PX0 4A0[2:0]	2

## SOFTWARE INTERRUPTS

Description	Flag Bit	Vector Address	Enable Bit	Interrupt Priority
Software Interrupt 1	SWR1	0100–0103	SWE1	(fixed at 1)
Software Interrupt 2	SWR2	0104–0107	SWE2	(fixed at 2)
Software Interrupt 3	SWR3	0108–010B	SWE3	(fixed at 3)
Software Interrupt 4	SWR4	010C–010F	SWE4	(fixed at 4)
Software Interrupt 5	SWR5	0110–0113	SWE5	(fixed at 5)
Software Interrupt 6	SWR6	0114–0117	SWE6	(fixed at 6)
Software Interrupt 7	SWR7	0118–011B	SWE7	(fixed at 7)

## Single-chip 16-bit microcontroller

XA-H4

## ABSOLUTE MAXIMUM RATINGS

Parameter	Rating	Unit
Operating temperature under bias	-55 to +125	°C
Storage temperature range	-65 to +150	°C
Voltage on any other pin to $V_{SS}$	-0.5 to $V_{DD}+0.5$ V	v
Maximum $I_{OL}$ per I/O pin	15	mA
Power dissipation (based on package heat transfer, not device power consumption)	1.5	W

## PRELIMINARY DC ELECTRICAL CHARACTERISTICS

$V_{DD} = 5.0$  V +/- 10% or 3.3 V +/- 10% unless otherwise specified;  $T_{amb} = -40^{\circ}\text{C}$  to  $+85^{\circ}\text{C}$  for industrial, unless otherwise specified.

Symbol	Parameter	Test Conditions	Limits			Unit
			Min	Typ	Max	
$I_{DD}$	Power supply current, operating	5.0 V, 30 MHz		64	80	mA
		3.3 V, 30 MHz		55	70	mA
$I_{ID}$	Power supply current, Idle mode	5.0 V, 30 MHz		50	70	mA
		3.3 V, 30 MHz		44	60	mA
$I_{PDI}$	Power supply current, Power Down mode <sup>1</sup>	5.0 V, 3.0 V			500	$\mu\text{A}$
$V_{RAM}$	RAM keep-alive voltage		1.5			V
$V_{IL}$	Input low voltage		-0.5		$0.22 V_{DD}$	V
$V_{IH}$	Input high voltage, except Xtal1, RST		2.2			V
$V_{IH1}$	Input high voltage to Xtal1, RST	For both 3.0 & 5.0 V	$0.7 V_{DD}$			V
$V_{OL}$	Output low voltage all ports <sup>8</sup>	$I_{OL} = 3.2$ mA, $V_{DD} = 4.5$ V			0.5	V
		$I_{OL} = 1.0$ mA, $V_{DD} = 3.0$ V			0.4	V
$V_{OH1}$	Output high voltage, all ports	$I_{OH} = -100$ $\mu\text{A}$ , $V_{DD} = 4.5$ V	2.4			V
		$I_{OH} = -30$ $\mu\text{A}$ , $V_{DD} = 3.0$ V	2.0			V
$V_{OH2}$	Output high voltage, all ports	$I_{OH} = 3.2$ mA, $V_{DD} = 4.5$ V	2.4			V
		$I_{OH} = 1.0$ mA, $V_{DD} = 3.0$ V	2.2			V
$C_{IO}$	Input/Output pin capacitance				15	pF
$I_{IL}$	Logical 0 input current, all ports <sup>7</sup>	$V_{IN} = 0.45$ V			-50	$\mu\text{A}$
$I_{LI}$	Input leakage current, all ports <sup>6</sup>	$V_{IN} = V_{IL}$ or $V_{IH}$			$\pm 10$	$\mu\text{A}$
$I_{TL}$	Logical 1 to 0 transition current, all ports <sup>5</sup>	At $V_{DD} = 5.5$ V			-650	$\mu\text{A}$
		At $V_{DD} = 3.6$ V			-250	$\mu\text{A}$

## NOTE:

- $V_{DD}$  must be raised to within the operating range before power down mode is exited.
- Ports in quasi-bidirectional mode with weak pullup.
- Ports in PUSH-PULL mode, both pullup and pulldown assumed to be the same strength.
- In all output modes.
- Port pins source a transition current when used in quasi-bidirectional mode and externally driven from 1 to 0. This current is highest when  $V_{IN}$  is approximately 2 V.
- Measured with port in high impedance mode.
- Measured with port in quasi-bidirectional mode.
- Under steady state (non-transient) conditions,  $I_{OL}$  must be externally limited as follows:
 

Maximum $I_{OL}$ per port pin:	15 mA (NOTE: This is $+85^{\circ}\text{C}$ specification for $V_{DD} = 5$ V)
Maximum $I_{OL}$ per 8-bit port:	26 mA
Maximum total $I_{OL}$ for all outputs:	71 mA

If  $I_{OL}$  exceeds the test condition,  $V_{OL}$  may exceed the related specification. Pins are not guaranteed to sink current greater than the listed test conditions.

## Single-chip 16-bit microcontroller

XA-H4

**PRELIMINARY AC ELECTRICAL CHARACTERISTICS (5.0 V +/-10%)** $V_{DD} = 5.0 \text{ V} \pm 10\%$ ;  $T_{amb} = -40^\circ\text{C}$  to  $+85^\circ\text{C}$  (industrial)

Symbol	Figure	Parameter	Limits		Unit
			Min	Max	
<b>All Cycles</b>					
$F_C$		System Clock Frequency	0	30	MHz
$t_C$	23	System Clock Period = $1/F_C$	33.33	–	ns
$t_{CHCX}$	23	XTALIN High Time	$t_C^* 0.5$	–	ns
$t_{CLCX}$	23	XTALIN Low Time	$t_C^* 0.4$	–	ns
$t_{CLCH}$	23	XTALIN Rise Time	–	5	ns
$t_{CHCL}$	23	XTALIN Fall Time	–	5	ns
$t_{AVSL}$	All	Address Valid to Strobe low	$t_C - 21$	–	ns
$t_{CHAH}$	All	Address hold after ClkOut rising edge <sup>9</sup>	1	–	ns
$t_{CHAV}$	All	Delay from ClkOut rising edge to address valid	–	25	ns
$t_{CHSH}$	All	Delay from ClkOut rising edge to Strobe High <sup>9</sup>	1	21	ns
$t_{CHSL}$	All	Delay from ClkOut rising edge to Strobe Low <sup>9</sup>	1	19	ns
$t_{CODH}$	24	ClkOut Duty Cycle High (into 40 pF max.)	$t_{CHCX} - 7$	$t_{CHCX} + 3$	ns
$t_{CPWH}$	11, 12, 17, 18, 19, 20	$\overline{CAS}$ Pulse Width High	$t_C - 12$	–	ns
$t_{CPWL}$	11, 19	$\overline{CAS}$ Pulse Width Low	$t_C - 10$	–	ns
<b>All DRAM Cycles</b>					
$t_{RP}$	22	RAS precharge time, thus minimum RAS high time <sup>8</sup>	$(n * t_C) - 16^8$	–	ns
<b>Generic Data Read Only</b>					
$t_{AHDR}$	7, 14	Address hold (A19 – A1 only, not A0) after $\overline{CS}$ , $\overline{BLE}$ , $\overline{BHE}$ rise at end of Generic Data Read Cycle (not code fetch)	$t_C - 12$	–	ns
<b>Data Read and Instruction Fetch Cycles</b>					
$t_{DIS}$	7, 8, 10, 11, 12, 14, 15, 17, 18, 19	Data In Valid setup to ClkOut rising edge	25	–	ns
$t_{DIH}$	7, 8, 10, 14, 15, 17, 18	Data In Valid hold after ClkOut rising edge <sup>2</sup>	0	–	ns
$t_{OHDE}$	8, 10, 11, 14, 18	$\overline{OE}$ high to XA Data Bus Driver Enable	$t_C - 14$	–	ns
<b>Write Cycles</b>					
$t_{CHDV}$	9, 13	Clock High to Data Valid	–	25	ns
$t_{DVSL}$	16, 20	Data Valid prior to Strobe Low	$t_C - 23$	–	ns
$t_{SHAH}$	9, 16	Minimum Address Hold Time after strobe goes inactive	$t_C - 25$	–	ns
$t_{SHDH}$	9, 16	Data hold after strobes ( $\overline{CS}$ and $\overline{BHE}/\overline{BLE}$ ) high	$t_C - 25$	–	ns
<b>Refresh</b>					
$t_{CLRL}$	21	$\overline{CAS}$ low to $\overline{RAS}$ low	$t_C - 15$	–	ns
<b>Wait Input</b>					
$t_{WS}$	25	WAIT setup (stable high or low) to ClkOut rising edge	20	–	ns
$t_{WH}$	25	WAIT hold (stable high or low) after ClkOut rising edge	0	–	ns

**NOTE:**

1. See notes after the 3.3 V AC Timing Table

## Single-chip 16-bit microcontroller

XA-H4

**AC ELECTRICAL CHARACTERISTICS (3.3 V +/-10%)** $V_{DD} = 3.3 \text{ V} \pm 10\%$ ;  $T_{amb} = -40^{\circ}\text{C}$  to  $+85^{\circ}\text{C}$  (industrial)

Symbol	Figure	Parameter	Limits		Unit
			Min	Max	
<b>All Cycles</b>					
$F_C$		System Clock (internally called CClk) Frequency	0	30	MHz
$t_c$	23	System Clock Period = $1/F_C$	33.33	–	ns
$t_{CHCX}$	23	XTALIN High Time	$t_c * 0.5$	–	ns
$t_{CLCX}$	23	XTALIN Low Time	$t_c * 0.4$	–	ns
$t_{CLCH}$	23	XTALIN Rise Time	–	5	ns
$t_{CHCL}$	23	XTALIN Fall Time	–	5	ns
$t_{AVSL}$	All	Address Valid to Strobe low	$t_c - 21$	–	ns
$t_{CHAH}$	All	Address hold after ClkOut rising edge <sup>9</sup>	1	–	ns
$t_{CHAV}$	All	Delay from ClkOut rising edge to address valid	–	30	ns
$t_{CHSH}$	All	Delay from ClkOut rising edge to Strobe High <sup>9</sup>	1	28	ns
$t_{CHSL}$	All	Delay from ClkOut rising edge to Strobe Low <sup>9</sup>	1	25	ns
$t_{CODH}$	24	ClkOut Duty Cycle High (into 40 pF max.)	$t_{CHCX} - 7$	$t_{CHCX} + 3$	ns
$t_{CPWH}$	11, 12, 17, 18, 19, 20	$\overline{\text{CAS}}$ Pulse Width High	$t_c - 12$	–	ns
$t_{CPWL}$	11, 19	$\overline{\text{CAS}}$ Pulse Width Low	$t_c - 10$	–	ns
<b>All DRAM Cycles</b>					
$t_{RP}$	22	$\overline{\text{RAS}}$ precharge time, thus minimum $\overline{\text{RAS}}$ high time <sup>8</sup>	$(n * t_c) - 16^8$	–	ns
<b>Data Read Only</b>					
$t_{AHDR}$	7, 14	Address hold (A19 – A1 only, not A0) after $\overline{\text{CS}}$ , $\overline{\text{BLE}}$ , $\overline{\text{BHE}}$ rise at end of Data Read Cycle (not code fetch)	$t_c - 12$	–	ns
<b>Data Read and Instruction Fetch Cycles</b>					
$t_{DIS}$	7, 8, 10, 11, 12, 14, 15, 17, 18, 19	Data In Valid setup to ClkOut rising edge	32	–	ns
$t_{DIH}$	7, 8, 10, 14, 15, 17, 18	Data In Valid hold after ClkOut rising edge <sup>2</sup>	0	–	ns
$t_{OHDE}$	8, 10, 11, 14, 18	$\overline{\text{OE}}$ high to XA Data Bus Driver Enable	$t_c - 19$	–	ns
<b>Write Cycles</b>					
$t_{CHDV}$	9, 13	Clock High to Data Valid	–	30	ns
$t_{DVSL}$	16, 20	Data Valid prior to Strobe Low	$t_c - 23$	–	ns
$t_{SHAH}$	9, 16	Minimum Address Hold Time after strobe goes inactive	$t_c - 25$	–	ns
$t_{SHDH}$	9, 16	Data hold after strobes ( $\overline{\text{CS}}$ and $\overline{\text{BHE/BLE}}$ ) high	$t_c - 25$	–	ns
<b>Refresh</b>					
$t_{CLRL}$	21	$\overline{\text{CAS}}$ low to $\overline{\text{RAS}}$ low	$t_c - 15$	–	ns
<b>Wait Input</b>					
$t_{WS}$	25	WAIT setup (stable high or low) prior to ClkOut rising edge	25	–	ns
$t_{WH}$	25	WAIT hold (stable high or low) after ClkOut rising edge	0	–	ns

**NOTE:**

- On a 16-bit bus, if only one byte is being written, then only one of  $\overline{\text{BLE\_CASL}}$  or  $\overline{\text{BHE\_CASH}}$  will go active. On an 8-bit bus,  $\overline{\text{BLE\_CASL}}$  goes active for all (odd or even address) accesses.  $\overline{\text{BHE\_CASH}}$  will not go active during any accesses on an 8-bit bus.
- The bus timing is designed to make meeting hold time very straightforward without glue logic. On all generic reads and fetches, in order to meet hold time, the slave should hold data valid on the bus until the earliest of  $\overline{\text{CS}}$ ,  $\overline{\text{BHE/BLE}}$ ,  $\overline{\text{OE}}$ , goes high (inactive), or until the address changes. On all FPM DRAM reads and fetches, hold data valid on the bus until a new  $\overline{\text{CAS}}$  is asserted, or until  $\overline{\text{OE}}$  goes high (inactive).
- To avoid 3-State fights during read cycles and fetch cycles, do not drive data bus until  $\overline{\text{OE}}$  goes active.
- To meet hold time, EDO DRAM drives data onto the bus until  $\overline{\text{OE}}$  rises, or until a new falling edge of  $\overline{\text{CAS}}$ .
- WARNING: ClkOut is specified at 40 pF max.** More than 40 pF on ClkOut may significantly degrade the ClkOut waveform. Load capacitance for all outputs (except ClkOut) = 80 pF.
- Not all combinations of bus timing configuration values result in valid bus cycles. Please refer to the *XA-H4 User Manual* for details.
- When code is being fetched on the external bus, a burst mode fetch is used. This burst can be from 2 to 16 bytes long. On a 16-bit bus, A3 – A1 are incremented for each new word of the burst. On an 8-bit bus, A3 – A0 are incremented for each new byte of the burst code fetch.

# Single-chip 16-bit microcontroller

XA-H4

8.  $t_{RP}$  is specified as the minimum high time (thus inactive) on each of the 5 individual  $\overline{CS\_RAS}[5:1]$  pins when such pin is programmed in the memory controller to service DRAM. The number of CClks (system clocks) in  $t_{RP}$  is programmable, and is represented by  $n$  in the  $t_{RP}$  equation in the AC tables. Regardless of what value is programmed into the control register,  $n$  will never be less than 2 clocks. Thus, at 30 Mhz system clock, the minimum value for  $\overline{RAS}$  precharge is  $t_{RP} = ((2 * t_C) - 16) = ((2 * 33.33) - 16) = 50.6$  ns. As the system clock frequency  $F_C$ , is slowed down,  $t_C$  (system clock period) of course becomes greater, and thus  $t_{RP}$  becomes greater.
9. The MIN value for this parameter is guaranteed by design and is not tested in production to the specified limit. In those cases where a maximum value is specified in the table for this parameter, it is tested.

## TIMING DIAGRAMS

All references to numbered Notes are to the notes following the AC Electrical Characteristics tables

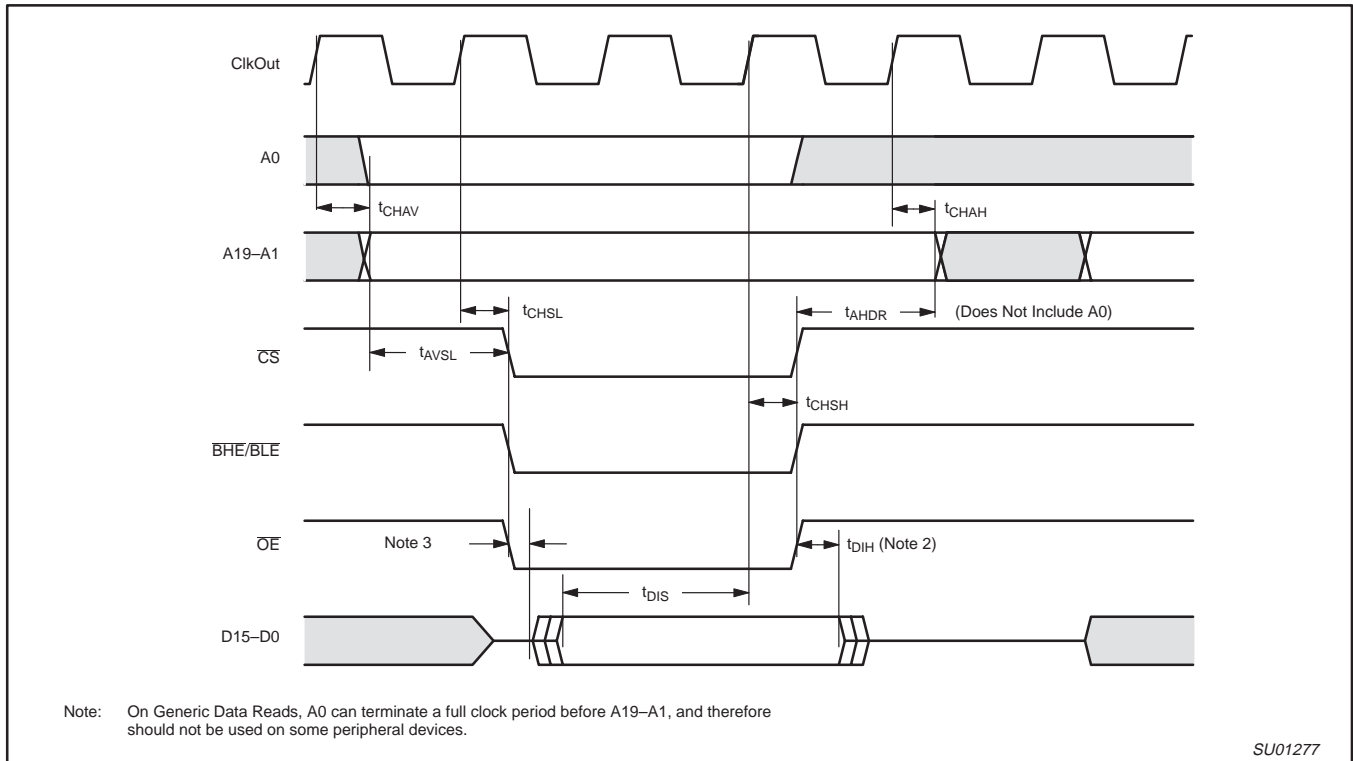

Figure 7. Generic (SRAM, ROM, Flash, I/O Devices, etc.) Read on 16-Bit Bus

Single-chip 16-bit microcontroller

XA-H4

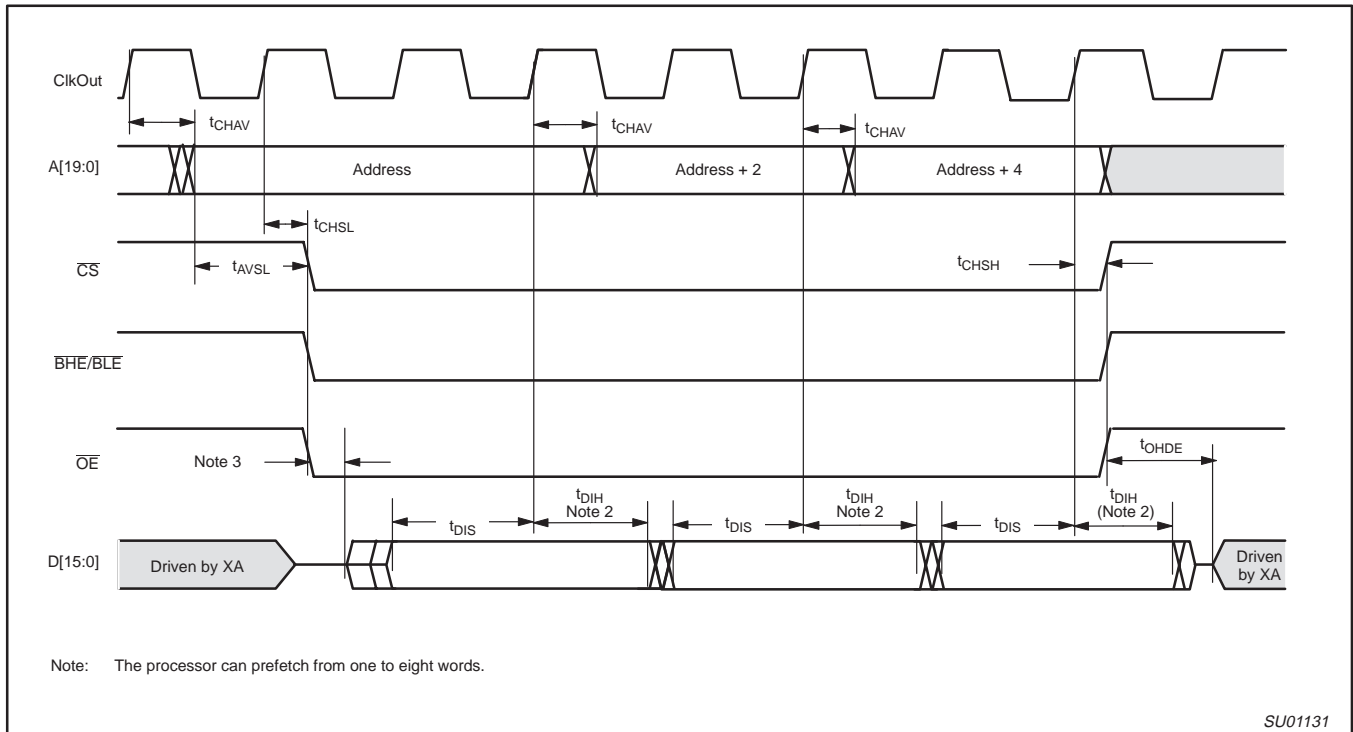

Figure 8. Generic (SRAM, ROM, Flash, etc.) Burst Code Fetch on 16-Bit Bus

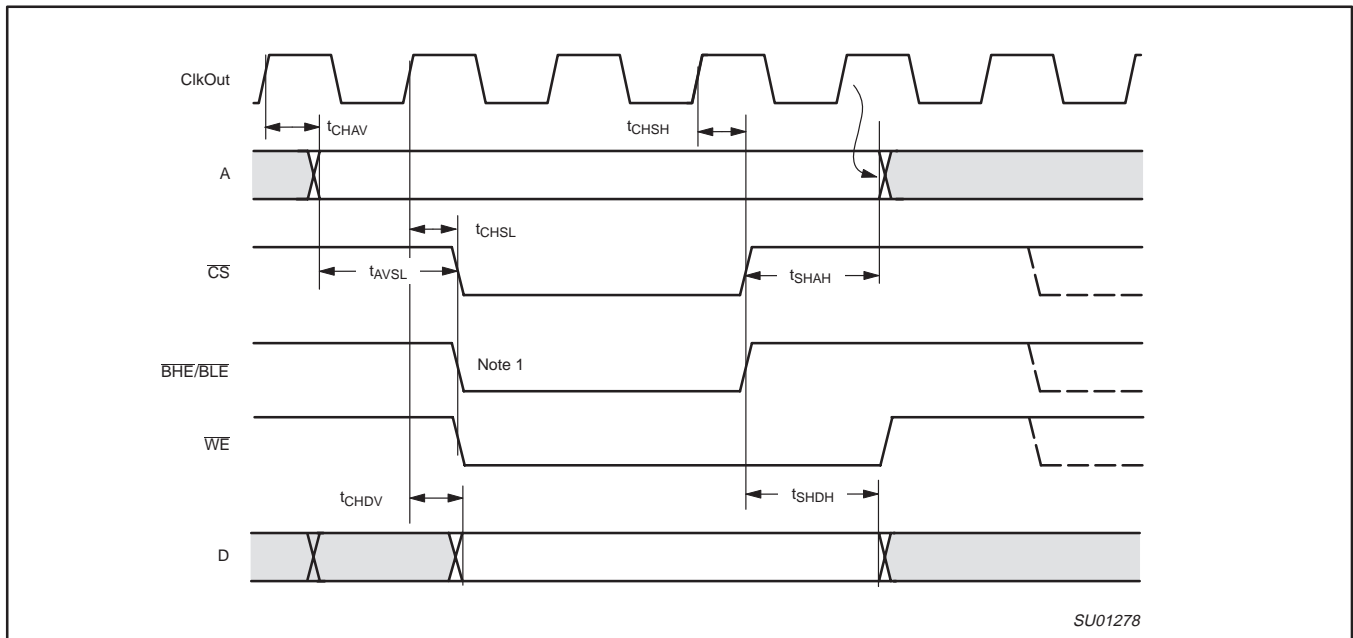

Figure 9. Generic (SRAM, I/O Devices, etc.) Write



Single-chip 16-bit microcontroller

XA-H4

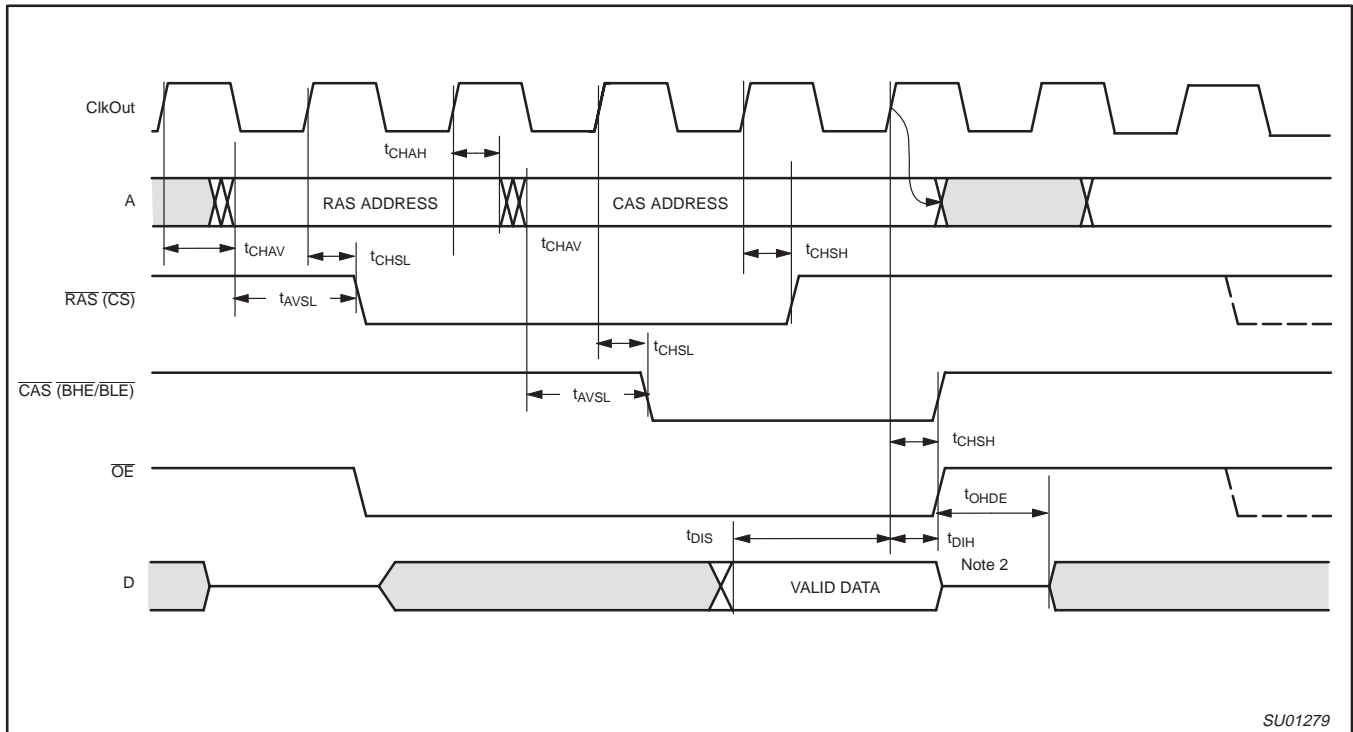
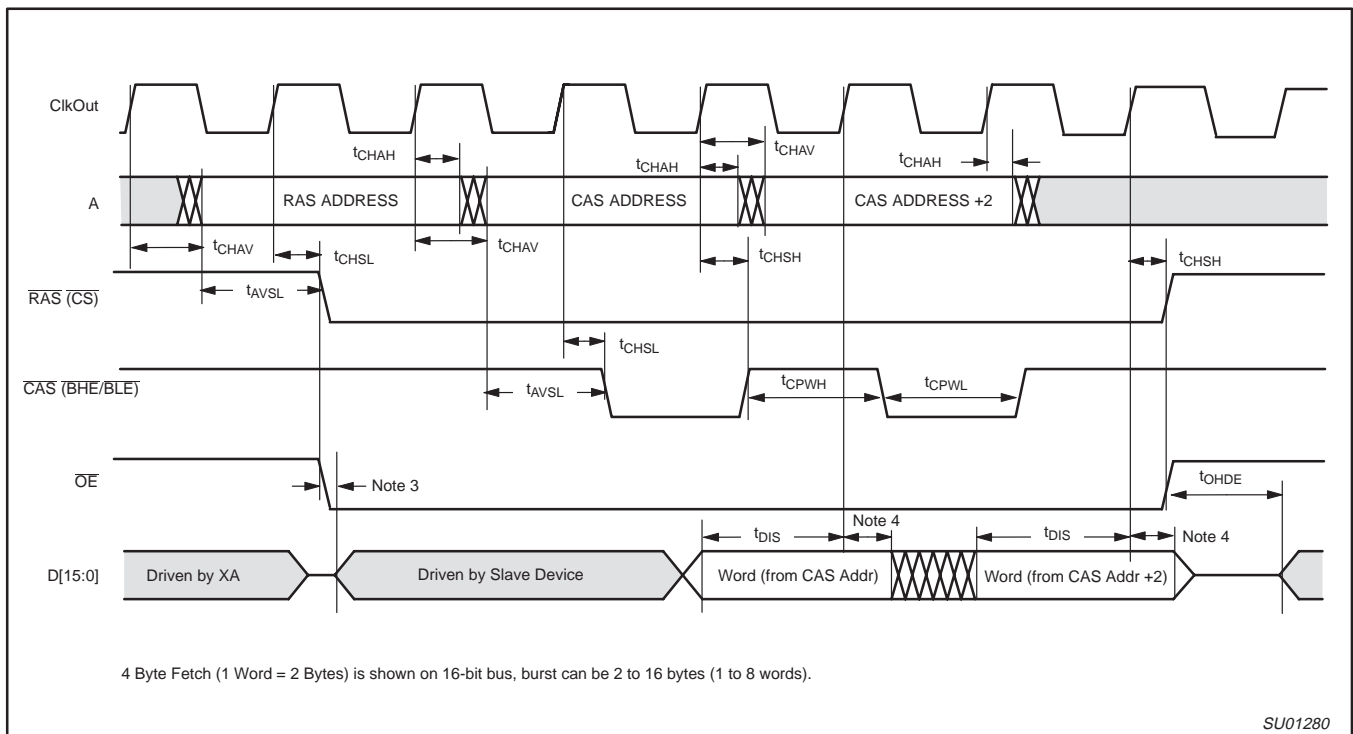

Figure 10. DRAM Single Read Cycle



4 Byte Fetch (1 Word = 2 Bytes) is shown on 16-bit bus, burst can be 2 to 16 bytes (1 to 8 words).

Figure 11. DRAM EDO Burst Code Fetch on 16-Bit Bus

Single-chip 16-bit microcontroller

XA-H4

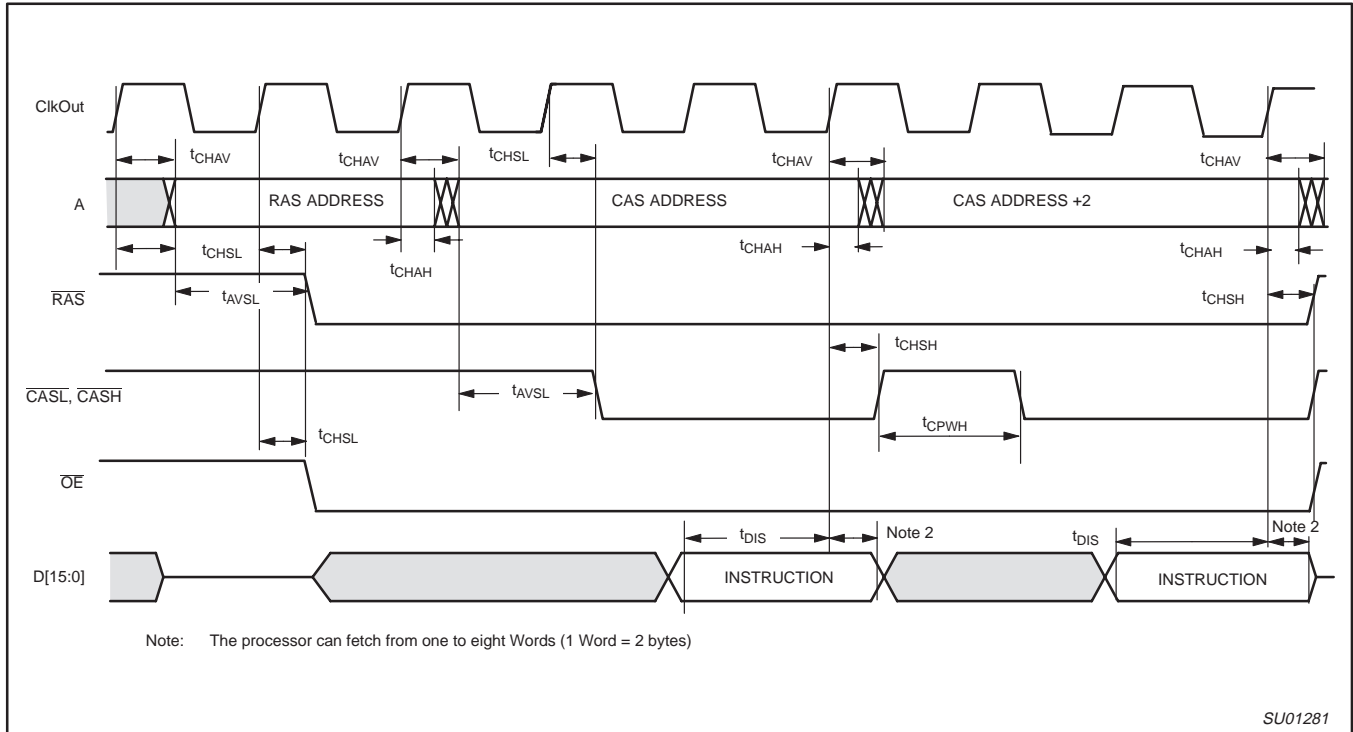

Figure 12. DRAM FPM (Fast Page Mode) Burst Code Fetch

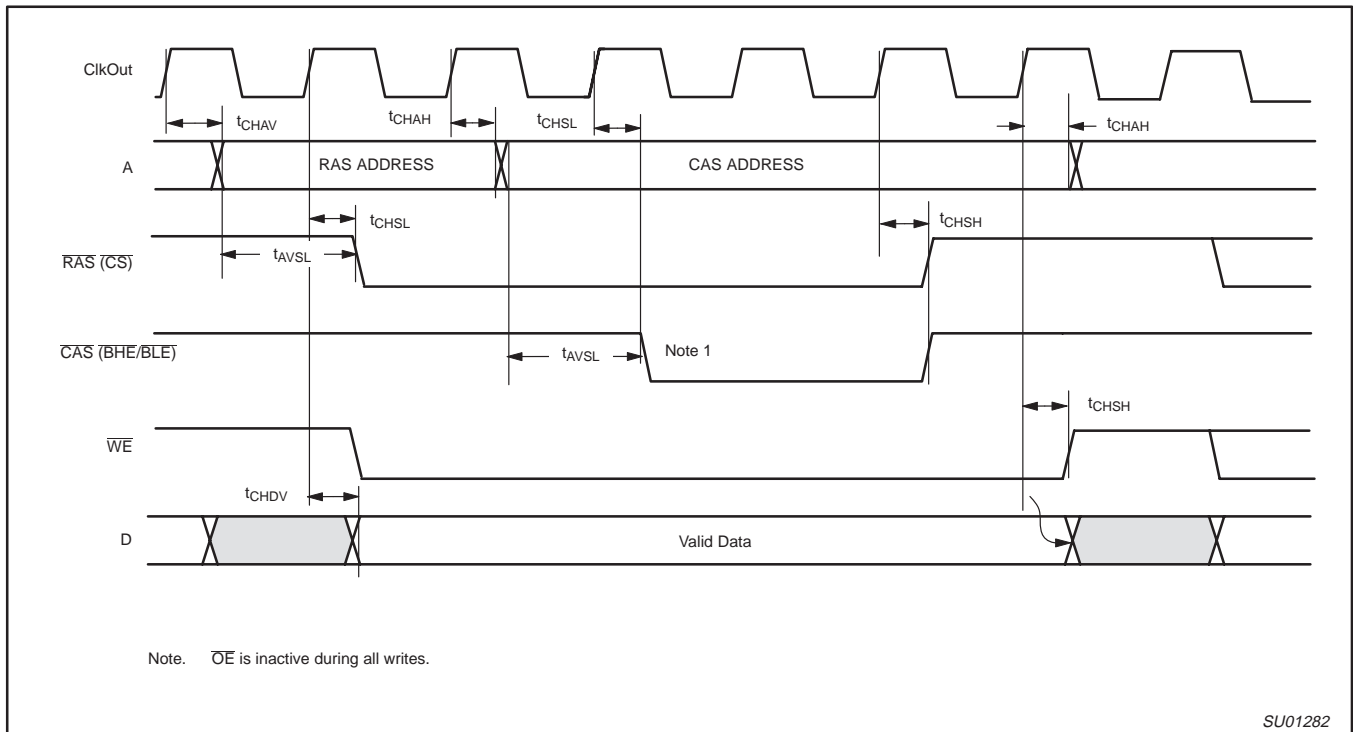

Figure 13. DRAM Write (on 16-Bit Bus, also 8-Bit Write on 8-Bit Bus)

# Single-chip 16-bit microcontroller

XA-H4

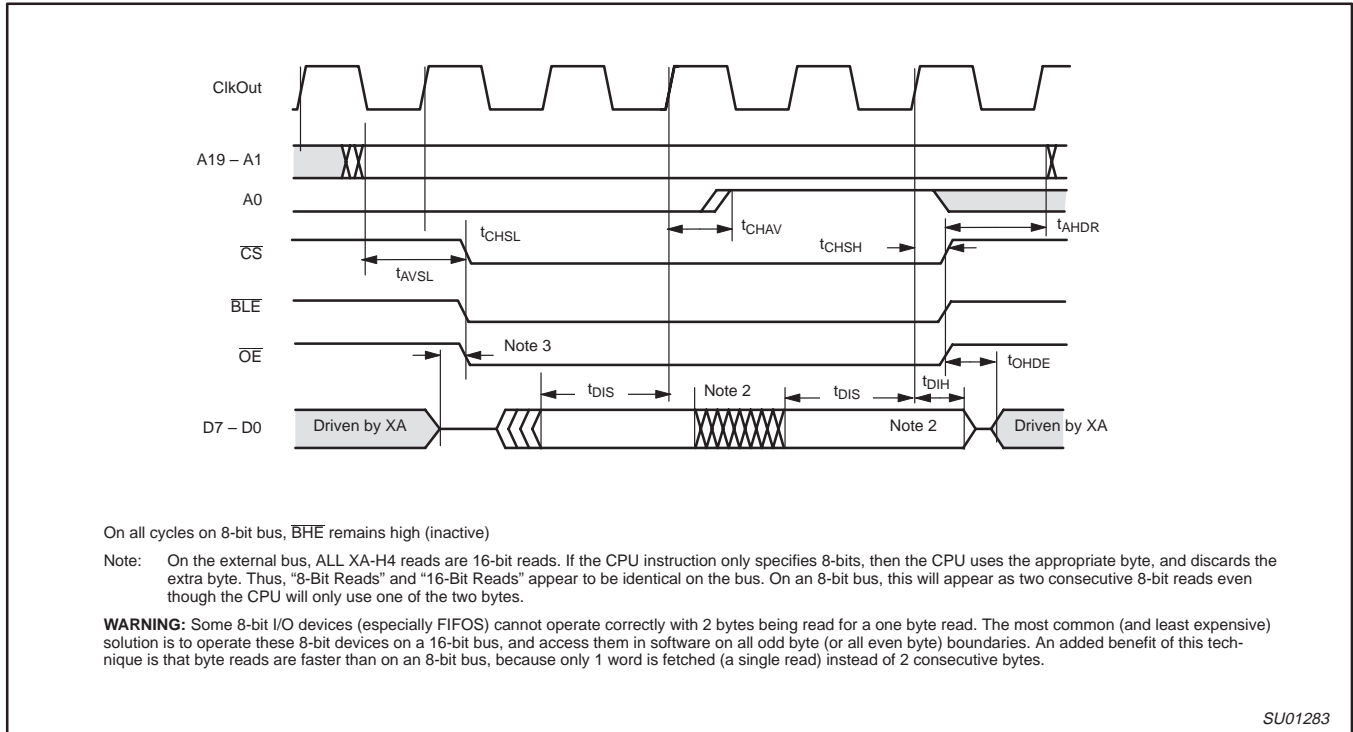

Figure 14. Generic (SRAM, Flash, I/O Device, etc.) Read (16-Bit or 8-Bit) on 8-Bit Bus

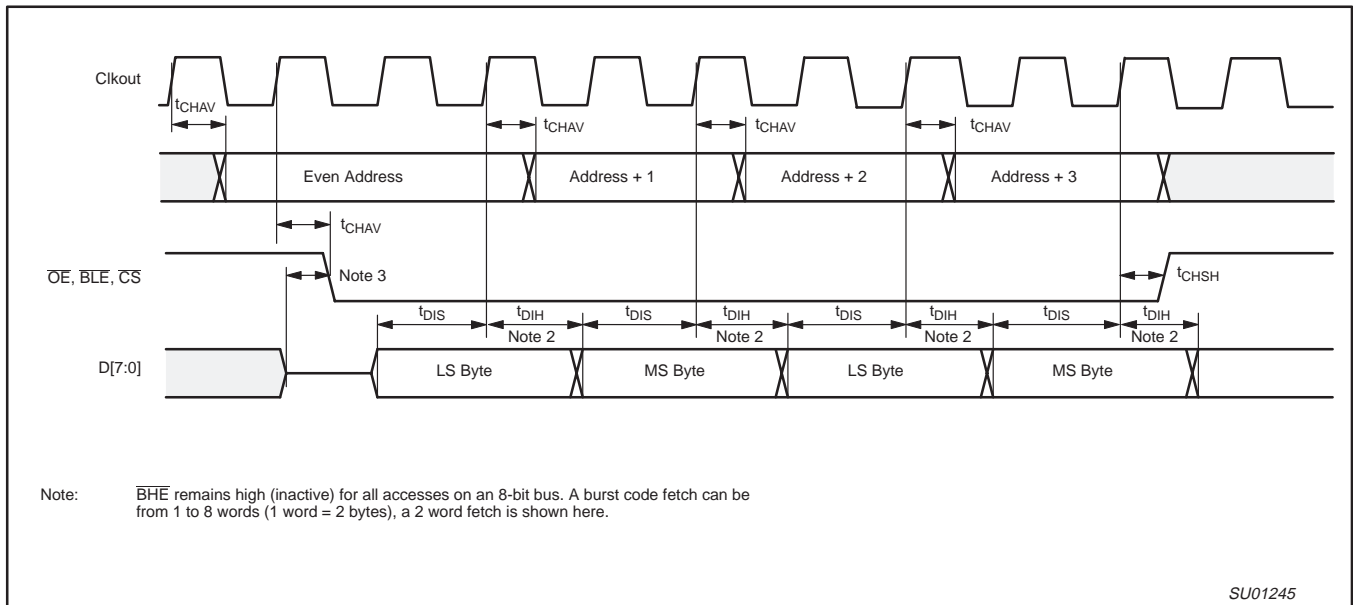

Figure 15. Burst Code Fetch on 8-Bit Bus, Generic Memory

Single-chip 16-bit microcontroller

XA-H4

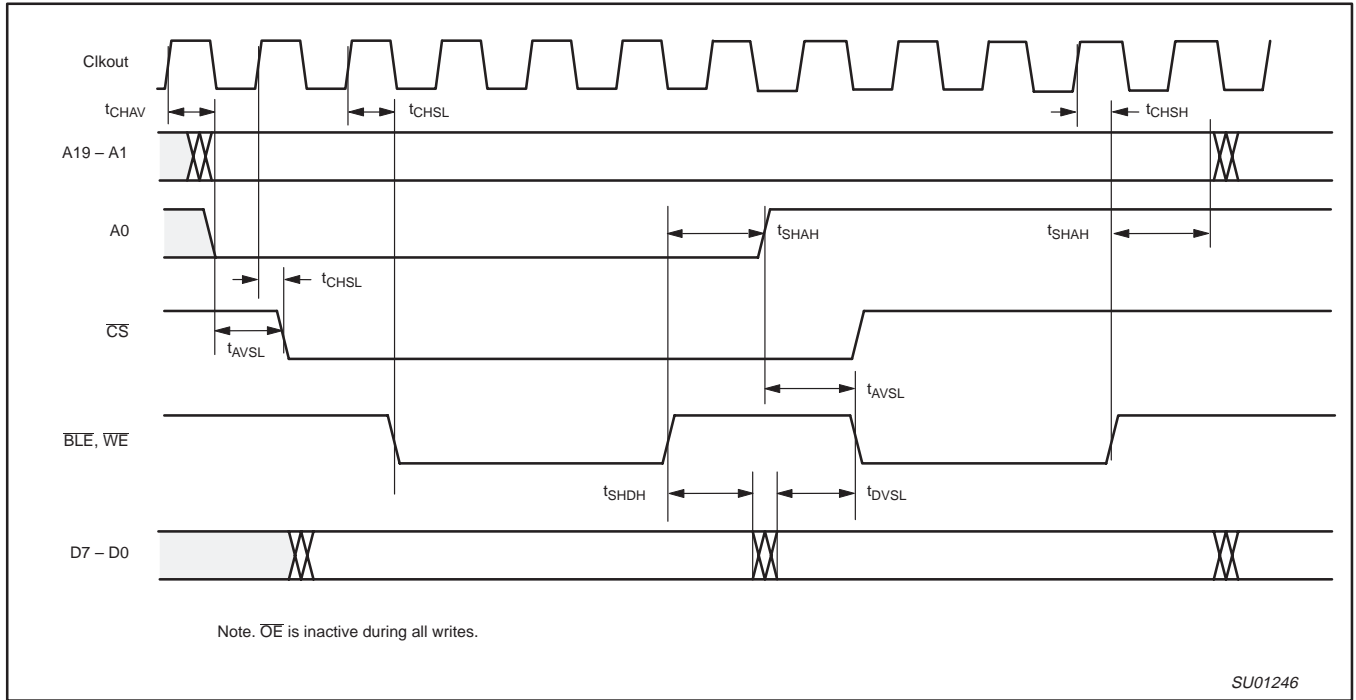

Figure 16. Generic 16-Bit Write on 8-Bit Bus

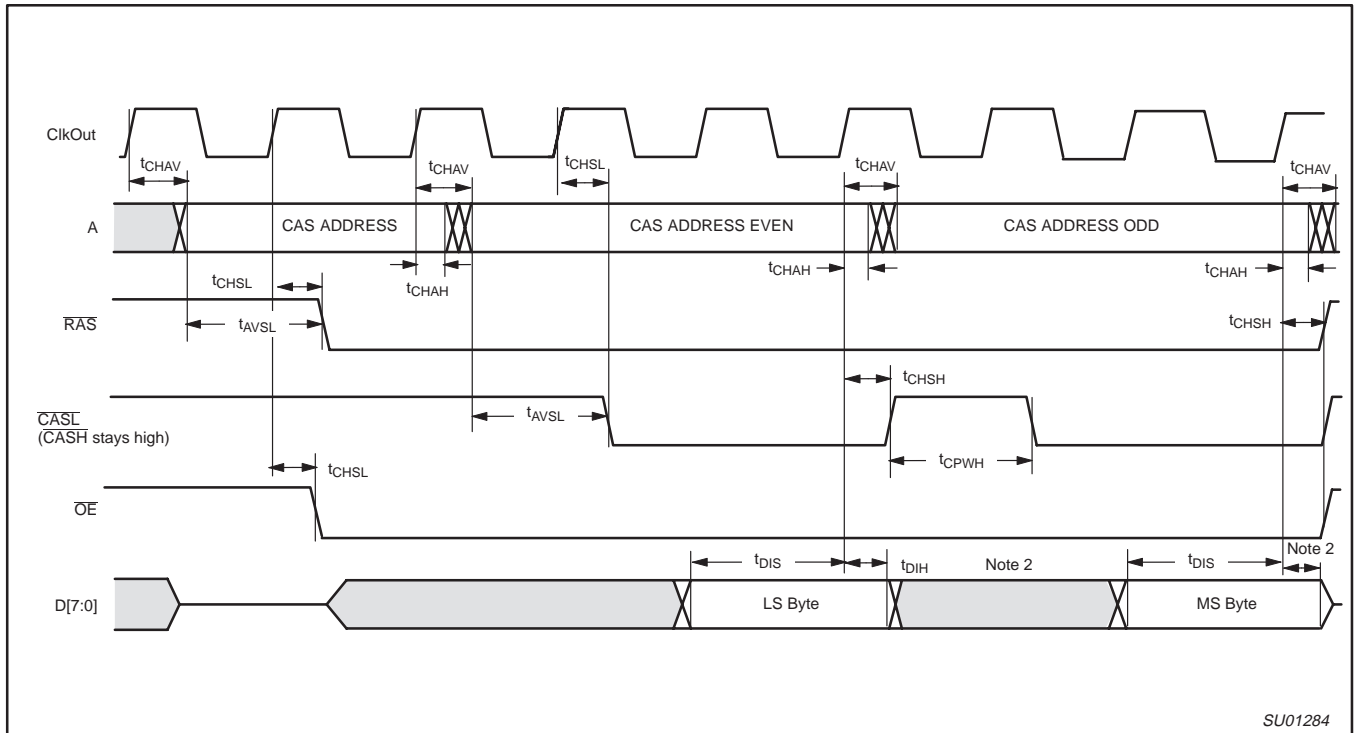

Figure 17. 16-Bit Read on 8-Bit Bus, DRAM (both FPM and EDO)

Single-chip 16-bit microcontroller

XA-H4

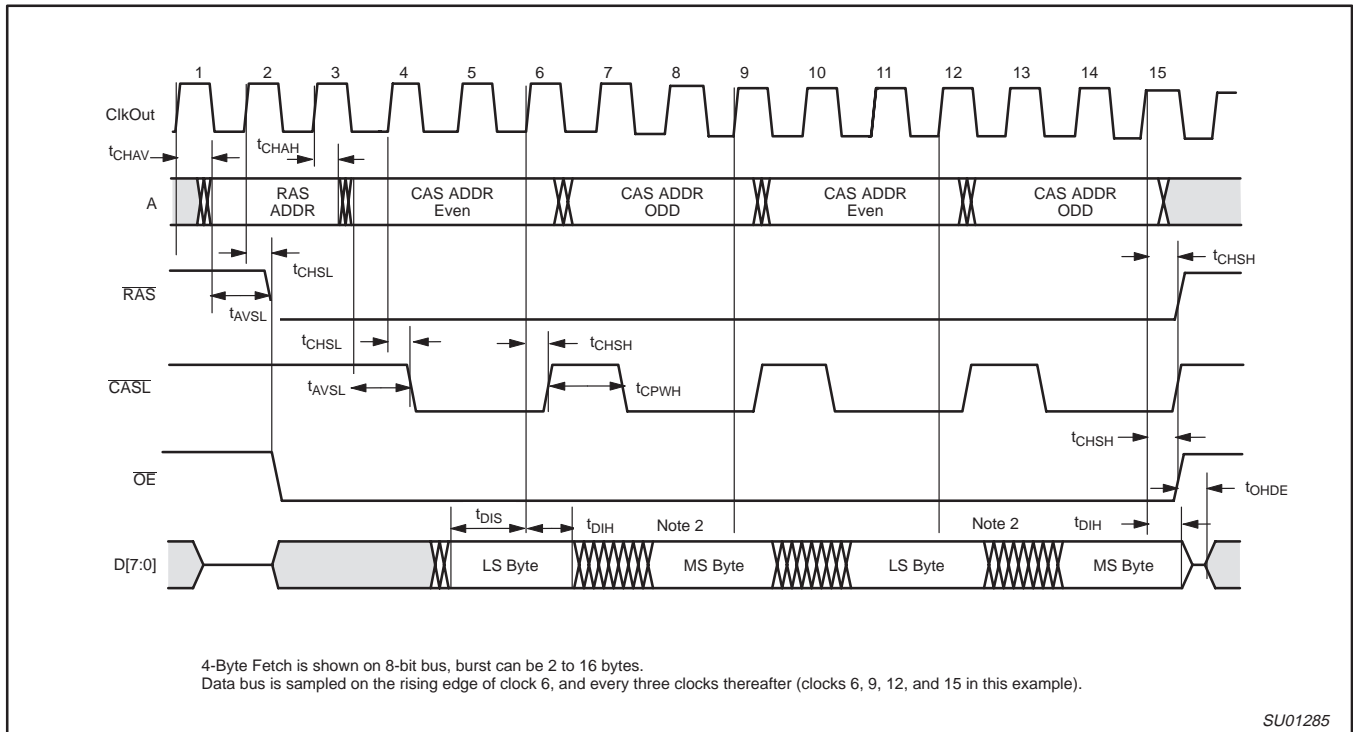

Figure 18. DRAM FPM (Fast Page Mode) Burst Code Fetch on 8-Bit Bus

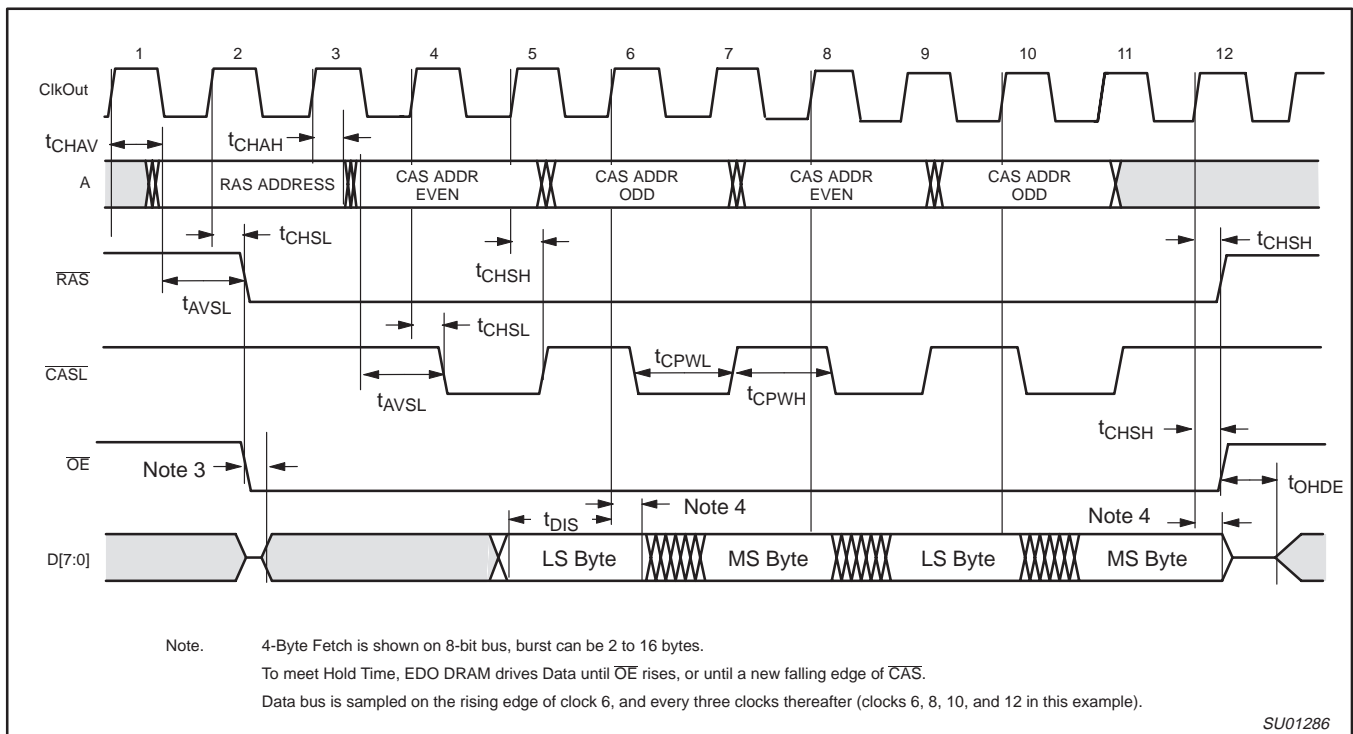

Figure 19. EDO DRAM Burst Code Fetch on 8-Bit Bus

Single-chip 16-bit microcontroller

XA-H4

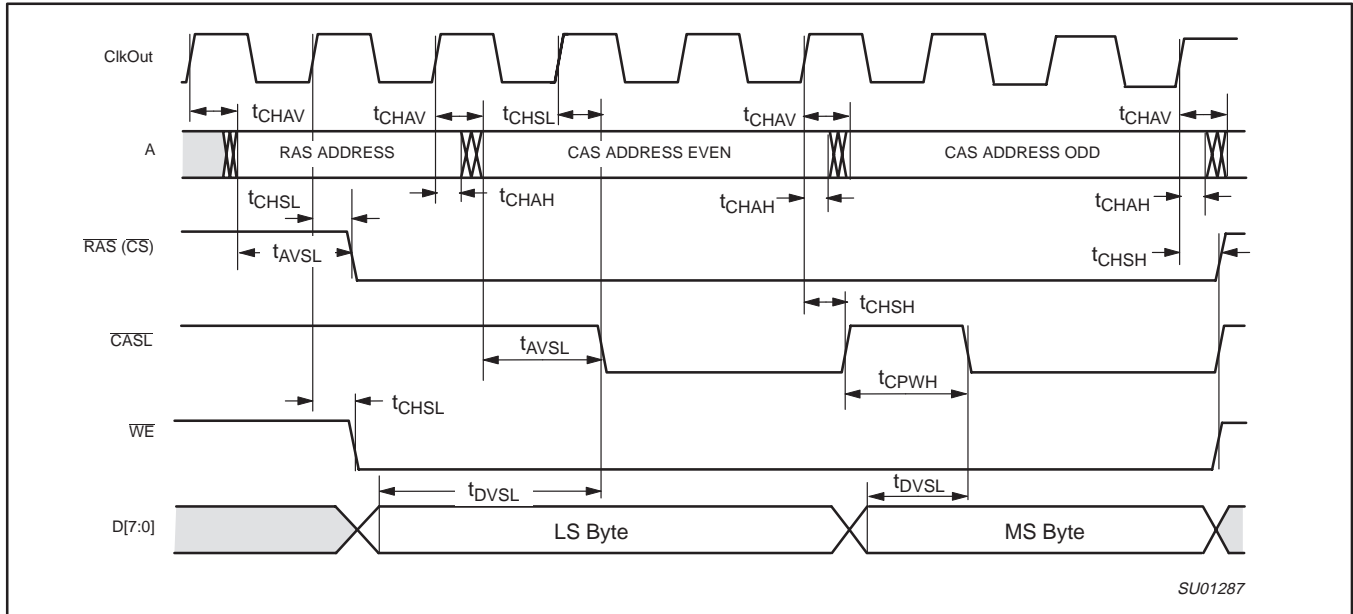
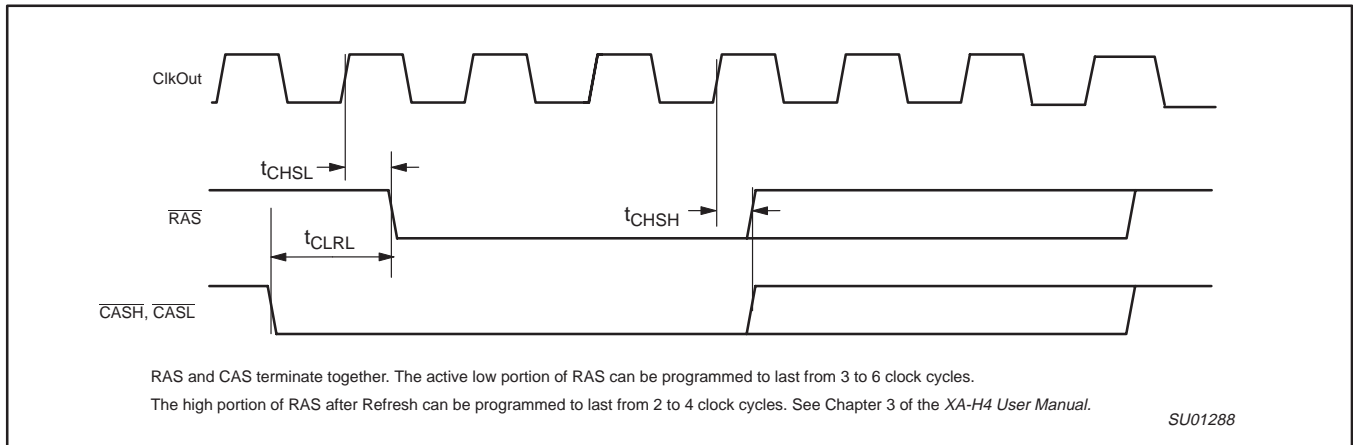

Figure 20. DRAM 16-Bit Write on 8-Bit Bus (FPM or EDO DRAMs)



RAS and CAS terminate together. The active low portion of RAS can be programmed to last from 3 to 6 clock cycles. The high portion of RAS after Refresh can be programmed to last from 2 to 4 clock cycles. See Chapter 3 of the XA-H4 User Manual.

SU01288

Figure 21. REFRESH

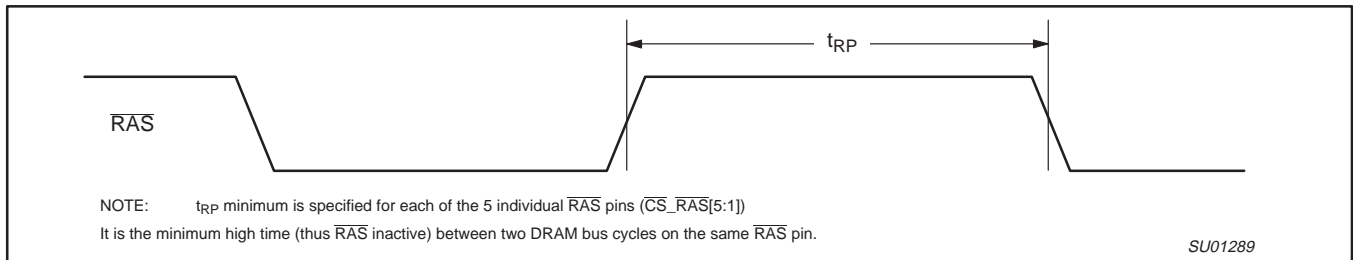

NOTE:  $t_{RP}$  minimum is specified for each of the 5 individual  $\overline{RAS}$  pins ( $\overline{CS\_RAS}[5:1]$ ). It is the minimum high time (thus  $\overline{RAS}$  inactive) between two DRAM bus cycles on the same  $\overline{RAS}$  pin.

SU01289

Figure 22.  $\overline{RAS}$  Precharge Time

# Single-chip 16-bit microcontroller

XA-H4

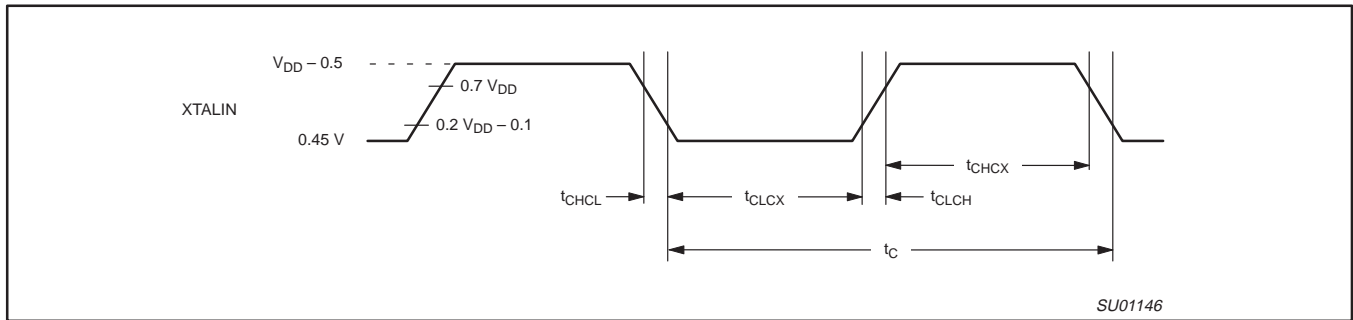

Figure 23. External Clock Input Drive

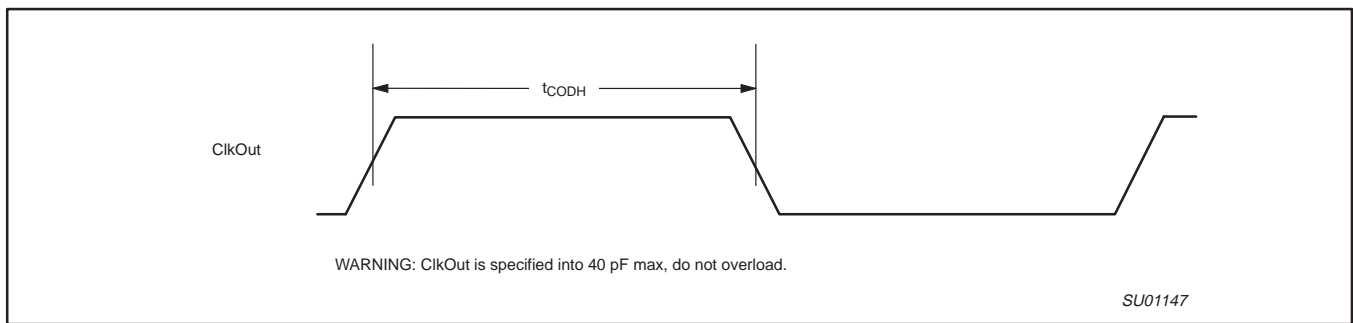

Figure 24. ClkOut Duty Cycle

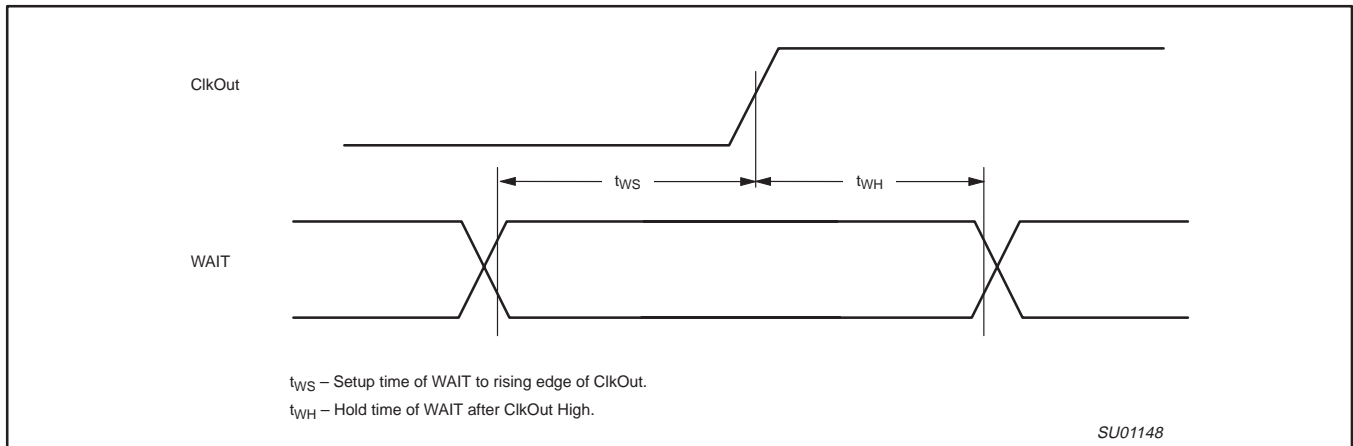

Figure 25. External WAIT Pin Timing

# Single-chip 16-bit microcontroller

XA-H4

**LQFP100: plastic low profile quad flat package; 100 leads; body 14 x 14 x 1.4 mm**

**SOT407-1**

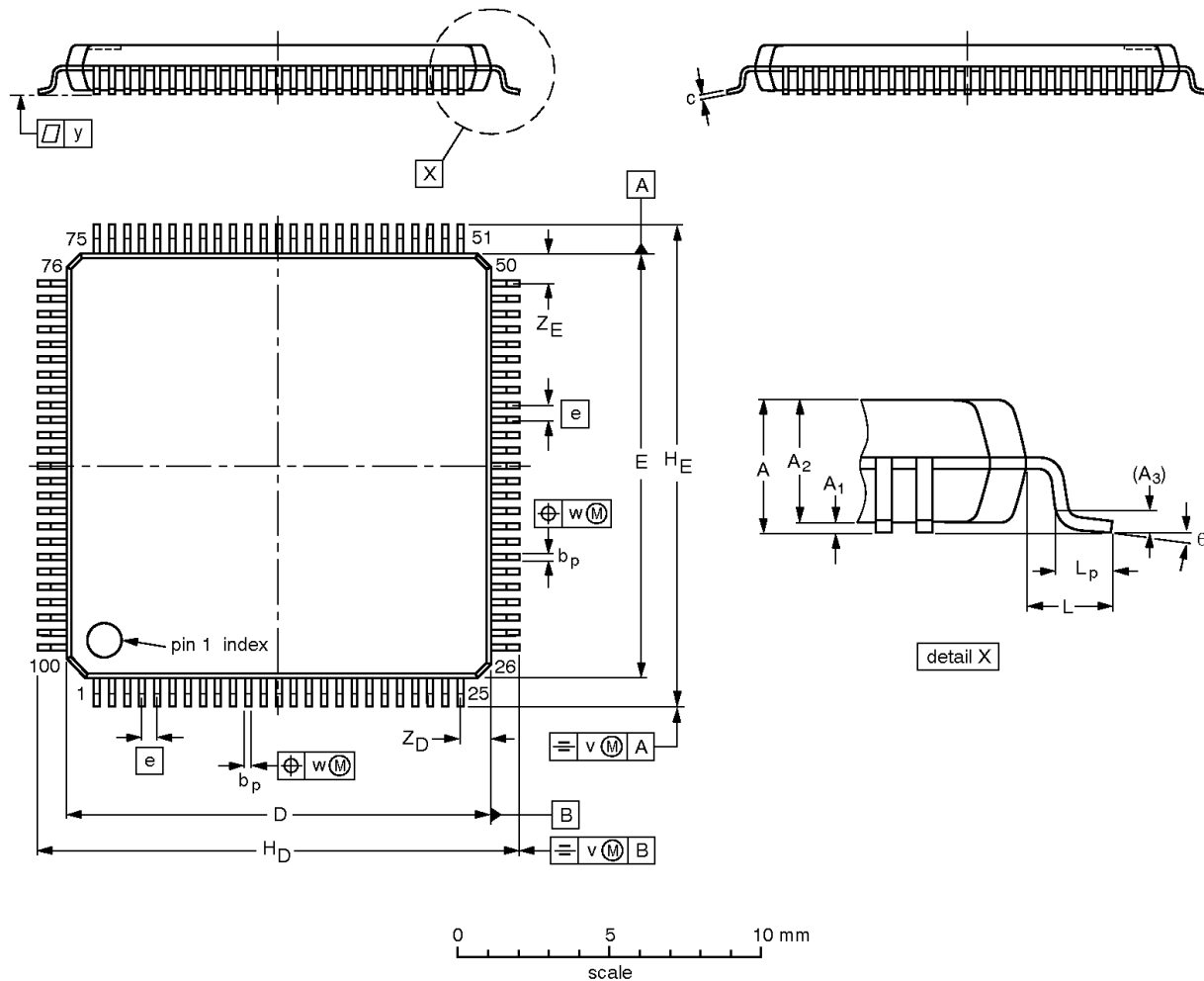

**DIMENSIONS (mm are the original dimensions)**

UNIT	A max.	A <sub>1</sub>	A <sub>2</sub>	A <sub>3</sub>	b <sub>p</sub>	c	D <sup>(1)</sup>	E <sup>(1)</sup>	e	H <sub>D</sub>	H <sub>E</sub>	L	L <sub>p</sub>	v	w	y	Z <sub>D</sub> <sup>(1)</sup>	Z <sub>E</sub> <sup>(1)</sup>	θ
mm	1.6	0.20 0.05	1.5 1.3	0.25	0.28 0.16	0.18 0.12	14.1 13.9	14.1 13.9	0.5	16.25 15.75	16.25 15.75	1.0	0.75 0.45	0.2	0.12	0.1	1.15 0.85	1.15 0.85	7° 0°

**Note**

1. Plastic or metal protrusions of 0.25 mm maximum per side are not included.

OUTLINE VERSION	REFERENCES				EUROPEAN PROJECTION	ISSUE DATE
	IEC	JEDEC	EIAJ			
SOT407-1						95-12-19 97-08-04



---

# Single-chip 16-bit microcontroller

XA-H4

---

## NOTES

## Single-chip 16-bit microcontroller

XA-H4

## Data sheet status

Data sheet status	Product status	Definition [1]
Objective specification	Development	This data sheet contains the design target or goal specifications for product development. Specification may change in any manner without notice.
Preliminary specification	Qualification	This data sheet contains preliminary data, and supplementary data will be published at a later date. Philips Semiconductors reserves the right to make changes at any time without notice in order to improve design and supply the best possible product.
Product specification	Production	This data sheet contains final specifications. Philips Semiconductors reserves the right to make changes at any time without notice in order to improve design and supply the best possible product.

[1] Please consult the most recently issued datasheet before initiating or completing a design.

## Definitions

**Short-form specification** — The data in a short-form specification is extracted from a full data sheet with the same type number and title. For detailed information see the relevant data sheet or data handbook.

**Limiting values definition** — Limiting values given are in accordance with the Absolute Maximum Rating System (IEC 134). Stress above one or more of the limiting values may cause permanent damage to the device. These are stress ratings only and operation of the device at these or at any other conditions above those given in the Characteristics sections of the specification is not implied. Exposure to limiting values for extended periods may affect device reliability.

**Application information** — Applications that are described herein for any of these products are for illustrative purposes only. Philips Semiconductors make no representation or warranty that such applications will be suitable for the specified use without further testing or modification.

## Disclaimers

**Life support** — These products are not designed for use in life support appliances, devices or systems where malfunction of these products can reasonably be expected to result in personal injury. Philips Semiconductors customers using or selling these products for use in such applications do so at their own risk and agree to fully indemnify Philips Semiconductors for any damages resulting from such application.

**Right to make changes** — Philips Semiconductors reserves the right to make changes, without notice, in the products, including circuits, standard cells, and/or software, described or contained herein in order to improve design and/or performance. Philips Semiconductors assumes no responsibility or liability for the use of any of these products, conveys no license or title under any patent, copyright, or mask work right to these products, and makes no representations or warranties that these products are free from patent, copyright, or mask work right infringement, unless otherwise specified.

Philips Semiconductors  
811 East Arques Avenue  
P.O. Box 3409  
Sunnyvale, California 94088-3409  
Telephone 800-234-7381

© Copyright Philips Electronics North America Corporation 1999  
All rights reserved. Printed in U.S.A.

Date of release: 09-99

Document order number:

9397 750 06432

*Let's make things better.*

# Mouser Electronics

Authorized Distributor

Click to View Pricing, Inventory, Delivery & Lifecycle Information:

[NXP:](#)

[PXA40KFBE,557](#)