

DATA SHEET

I•CODE SLI **Smart Label IC** **SL2 ICS20** Functional Specification

Product Specification

February 2005

Revision 3.1

Public

Functional Specification

Standard Label IC SL2 ICS20

CONTENTS

1	FEATURES.....	4
1.1	•CODE SLI RF Interface (ISO/IEC 15693).....	4
1.2	EEPROM.....	4
1.3	Security	4
2	GENERAL DESCRIPTION.....	5
2.1	Contactless Energy and Data Transfer.....	5
2.2	Anticollision.....	5
2.3	Security	5
3	FUNCTIONAL DESCRIPTION	6
3.1	Block Description.....	6
3.2	Memory Organisation	7
3.2.1	Unique Identifier	8
3.2.2	EAS Function.....	8
3.2.3	Application Family Identifier.....	9
3.2.4	Data Storage Format Identifier.....	9
3.2.5	Write Access Conditions	10
3.2.6	Configuration of delivered ICs	11
3.3	Communication Principle	11
3.4	Supported Commands	11
3.4.1	Mandatory commands	11
3.4.2	Optional commands.....	11
3.4.3	Custom commands.....	14
3.5	Error handling	19
3.5.1	Transmission errors	19
3.5.2	Not supported commands or options.....	19
3.5.3	Parameter out of range	19
3.6	Data Integrity	20
3.7	RF Interface.....	20
4	INLET/LABEL CHARACTERISATION AND TEST.....	21
5	DEFINITIONS	22
6	DISCLAIMERS.....	22
6.1	Life Support Applications	22
6.2	Licence Policy.....	22

Functional Specification

Standard Label IC SL2 ICS20

7 REVISION HISTORY 23

Functional Specification

Standard Label IC SL2 ICS20

1 FEATURES

1.1 **•CODE SLI RF Interface (ISO/IEC 15693)**

- Contactless transmission of data and supply energy (no battery needed)
- Operating distance: up to 1.5 m (depending on antenna geometry)
- Operating frequency: 13.56 MHz (ISM, world-wide licence free available)
- Fast data transfer: up to 53 kbit/s
- High data integrity: 16 Bit CRC, framing
- True anticollision
- Electronic Article Surveillance (EAS)
- Application Family Identifier (AFI) supported
- Data Storage Format Identifier (DSFID)
- Additional fast anticollision read
- Write distance equal to read distance

1.2 **EEPROM**

- 1024 bits, organised in 32 blocks of 4 byte each
- Data retention of 10 years
- Write endurance 100.000 cycles

1.3 **Security**

- Unique identifier for each device
- Lock mechanism for each user memory block (write protection)
- Lock mechanism for DSFID, AFI, EAS

Functional Specification

Standard Label IC SL2 ICS20

2 GENERAL DESCRIPTION

The I•CODE SLI IC is a dedicated chip for intelligent label applications like supply chain management as well as baggage and parcel identification in airline business and mail services. This IC is the first member of a product family of smart label ICs based on the ISO standard ISO/IEC 15693.

The I•CODE system offers the possibility of operating labels simultaneously in the field of the reader antenna (*Anticollision*). It is designed for long range applications.

2.1 Contactless Energy and Data Transfer

Whenever connected to a very simple and cheap type of antenna (as a result of the 13.56 MHz carrier frequency) made out of a few windings printed, wound, etched or punched coil the I•CODE SLI IC can be operated without line of sight up to a distance of 1.5 m (gate width). No battery is needed. When the smart label is positioned in the field of an interrogator antenna, the high speed RF communication interface allows to transmit data with up to 53 kbit/s.

2.2 Anticollision

An intelligent anticollision function allows to operate more than one tag in the field simultaneously. The anticollision algorithm selects each tag individually and ensures that the execution of a transaction with a selected tag is performed correctly without data corruption resulting from other tags in the field.

2.3 Security

Unique Identifiers, which can not be altered, guarantee the uniqueness of each label.

Functional Specification

Standard Label IC SL2 ICS20

3 FUNCTIONAL DESCRIPTION

3.1 Block Description

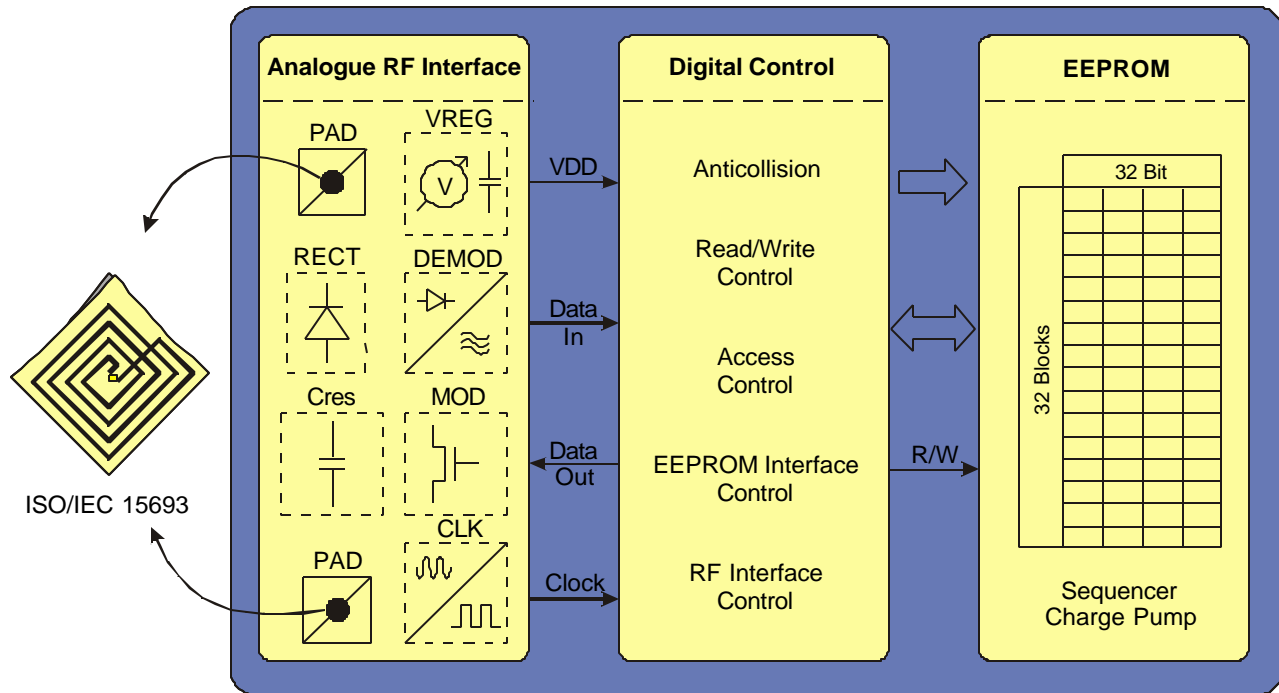

The label requires no internal power supply. Its contactless interface generates the power supply and the system clock via the resonant circuitry by inductive coupling to the interrogator. The interface also demodulates data that are transmitted from the interrogator to the I•CODE Label, and modulates the electromagnetic field for data transmission from the I•CODE Label to the interrogator.

Data are stored in a non-volatile memory (EEPROM). The EEPROM has a memory capacity of 1024 bit and is organised in 32 blocks consisting of 4 bytes each (1 block = 32 bits). The higher 28 blocks contain user data and the lowest 4 blocks contain the unique identifier, the write access conditions and special data like AFI and DSFID.

Functional Specification

Standard Label IC SL2 ICS20

3.2 Memory Organisation

The 1024 bit EEPROM memory is divided into 32 blocks. A block is the smallest access unit. Each block consists of 4 bytes (1 block = 32 bits). Bit 0 in each byte represents the least significant bit (LSB) and bit 7 the most significant bit (MSB), respectively.

	Byte 0	Byte 1	Byte 2	Byte 3	
Block -4	UID0	UID1	UID2	UID3	Unique Identifier (lower bytes)
Block -3	UID4	UID5	UID6	UID7	Unique Identifier (higher bytes)
Block -2	Internally used	EAS	AFI	DSFID	EAS, AFI, DSFID
Block -1	00	00	00	00	Write Access Conditions
Block 0	x	x	x	x	User Data
Block 1	x	x	x	x	
Block 2	x	x	x	x	
Block 3	x	x	x	x	
Block 4	x	x	x	x	
Block 5	x	x	x	x	
Block 6	x	x	x	x	
Block 7	x	x	x	x	
Block 8	x	x	x	x	
Block 9	x	x	x	x	
Block 10	x	x	x	x	
Block 11	x	x	x	x	
Block 12	x	x	x	x	
Block 13	x	x	x	x	
Block 14	x	x	x	x	
Block 15	x	x	x	x	
Block 16	x	x	x	x	
Block 17	x	x	x	x	
Block 18	x	x	x	x	
Block 19	x	x	x	x	
Block 20	x	x	x	x	
Block 21	x	x	x	x	
Block 22	x	x	x	x	
Block 23	x	x	x	x	
Block 24	x	x	x	x	
Block 25	x	x	x	x	
Block 26	x	x	x	x	
Block 27	x	x	x	x	

The values (in hexadecimal notation) shown in the table above are stored in the EEPROM after the wafer production process. The contents of blocks marked with 'x' in the table are **not** defined at delivery.

With read and write commands only blocks 0 to 27 can be addressed.

Functional Specification

Standard Label IC SL2 ICS20

3.2.1 UNIQUE IDENTIFIER

The 64 bit unique identifier (UID) is programmed during the production process according to ISO/IEC 15693-3 and cannot be changed afterwards.

The numbering of the 64 bits is done according to ISO/IEC 15693-3 starting with the LSB 1 and ending with the MSB 64. This is in contrast to the general used bit numbering within a byte.

The TAG type is a part of the UID (bit41 to 48, after the manufacturer code which is "04" hex for Philips Semiconductors).

The TAG type of the SL2 ICS20 is "01" hex.

MSB						LSB	
64	57	56	49	48	41	40	1
<i>"E0"</i>		<i>"04"</i>		<i>"01"</i>		<i>IC manufacturer serial number</i>	
UID 7		UID 6		UID 5		UID 4	UID 3
						UID 2	UID 1
						UID 0	

3.2.2 EAS FUNCTION

The LSB of Byte 1 in Block -2 holds the EAS bit (Electronic Article Surveillance mode active → the label responds to an EAS command)

Block -2, Byte 1							
MSB							LSB
X	X	X	X	X	X	X	e
							EAS

EAS: e = 1 → EAS enabled

e = 0 → EAS disabled

Changing of the EAS Configuration must be done in secure environment. The label must not be moved out of the communication field of the antenna during writing! We recommend to put the label close to the antenna and not to remove it during operation.

Functional Specification

Standard Label IC SL2 ICS20

3.2.3 APPLICATION FAMILY IDENTIFIER

The I²C CODE system offers the feature to use an Application Family Identifier (AFI) at the *inventory* command and the two custom commands *inventory read* and *fast inventory read* (this allows for example the creation of 'label families').

This 8-bit value is located at Byte 2 in Block -2 as shown in the following figure and is only evaluated if the AFI flag is set in the reader command.

For details please refer to ISO 15693-3.

Block -2, Byte 2							
MSB							LSB
X	X	X	X	X	X	X	X
AFI							

3.2.4 DATA STORAGE FORMAT IDENTIFIER

The Data Storage Format Identifier (DSFID) is located at Byte 3 in Block -2.

For details please refer to ISO/IEC 15693-3.

Block -2, Byte 3							
MSB							LSB
X	X	X	X	X	X	X	X
DSFID							

Functional Specification

Standard Label IC SL2 ICS20

3.2.5 WRITE ACCESS CONDITIONS

The Write Access Condition bits in block -1 determine the write access conditions for each of the 28 user blocks and the special data block. These bits can be set only to 1 with a lock command (and never be changed back to 0), i.e. already write protected blocks can never be written to from this moment on.

In block -2 each byte can be individually locked.

		Block -1															
		Byte 0								Byte 1							
		MSB				LSB				MSB				LSB			
Condition		0	0	0	0	0	0	0	0	0	0	0	0	0	0	0	0
Write access for block number		3	2	1	0	-2 (3)	-2 (2)	-2 (1)	-2 (0)	11	10	9	8	7	6	5	4

		Block -1															
		Byte 2								Byte 3							
		MSB				LSB				MSB				LSB			
Condition		0	0	0	0	0	0	0	0	0	0	0	0	0	0	0	0
Write access for block number		19	18	17	16	15	14	13	12	27	26	25	24	23	22	21	20

Changing of the Write Access conditions must be done in secure environment. The label must not be moved out of the communication field of the antenna during writing! We recommend to put the label close to the antenna and not to remove it during operation.

Functional Specification

Standard Label IC SL2 ICS20

3.2.6 CONFIGURATION OF DELIVERED ICS

ICCODE SLI ICs are delivered with the following configuration by Philips:

- Unique Identifier is unique and read only
- Write Access Conditions allow to change all blocks (with the exception of both UID blocks).
- Status of EAS mode is **not** defined
- AFI is supported and **not** defined
- DSFID is supported and **not** defined
- User Data memory is **not** defined

NOTE: Due to the fact that the EAS mode is undefined at delivery, the EAS MODE shall be set (enable or disable) according to your application requirements during the test or initialisation phase.

3.3 Communication Principle

For detailed description of the protocol and timing please refer to ISO/IEC 15693-2 (modulation, bit-coding, framing) and 15693-3 (anticollision, timing, protocol).

3.4 Supported Commands

3.4.1 MANDATORY COMMANDS

3.4.1.1 *Inventory*

As defined in ISO/IEC 15693-3.

3.4.1.2 *Stay quiet*

As defined in ISO/IEC 15693-3.

3.4.2 OPTIONAL COMMANDS

3.4.2.1 *Read single block*

As defined in ISO/IEC 15693-3.

Option 0 (option flag not set) is supported.

Option 1 (option flag set) is supported.

Functional Specification

Standard Label IC SL2 ICS20

3.4.2.2 *Write single block*

As defined in ISO/IEC 15693-3.

Only Option 0 (option flag is not set) is supported.

3.4.2.3 *Lock block*

As defined in ISO/IEC 15693-3.

Only Option 0 (option flag is not set) is supported.

3.4.2.4 *Read multiple blocks*

As defined in ISO/IEC 15693-3.

Option 0 (option flag is not set) is supported.

Option 1 (option flag set) is supported.

Note: If the sum of the first block number and the number of blocks exceeds the total available number of user blocks the number of transmitted blocks is less than the requested number of blocks, which means that the last returned block is the highest available user block, followed by the 16 bit CRC and the EOF.

3.4.2.5 *Select*

As defined in ISO/IEC 15693-3.

3.4.2.6 *Reset to ready*

As defined in ISO/IEC 15693-3.

3.4.2.7 *Write AFI*

As defined in ISO/IEC 15693-3.

Only Option 0 (option flag is not set) is supported.

3.4.2.8 *Lock AFI*

As defined in ISO/IEC 15693-3.

Only Option 0 (option flag is not set) is supported.

Functional Specification

Standard Label IC SL2 ICS20

3.4.2.9 *Write DSFID*

As defined in ISO/IEC 15693-3.

Only Option 0 (option flag is not set) is supported.

3.4.2.10 *Lock DSFID*

As defined in ISO/IEC 15693-3.

Only Option 0 (option flag is not set) is supported.

3.4.2.11 *Get system information*

As defined in ISO/IEC 15693-3.

The TAG type of the SL2 ICS20 is "01" hex.

3.4.2.12 *Get multiple block security status*

As defined in ISO/IEC 15693-3.

Note: If the sum of the first block number and the number of blocks exceeds the total available number of user blocks the number of transmitted security status bytes is less than the requested number, which means that the last returned status byte is the one corresponding to the highest available user block, followed by the 16 bit CRC and the EOF.

Functional Specification

Standard Label IC SL2 ICS20

3.4.3 CUSTOM COMMANDS

The manufacturer code of Philips is defined in ISO/IEC 7816-6A1. It has the value "04" hex.

For the structure of custom commands please refer to ISO/IEC 15693-3.

3.4.3.1 *Inventory read*

Command Code = A0 hex

When receiving the *inventory read* request, the \blacklozenge CODE SLI IC performs the same as in the anti-collision sequence, with the difference that instead of the UID and the DSFID the requested memory content is re-transmitted from the \blacklozenge CODE SLI IC.

If an error is detected the \blacklozenge CODE SLI IC remains silent.

If the option flag is set to 0 n blocks of data are re-transmitted. If the option flag is set to 1 n blocks of data and the part of the UID which is not part of the mask are re-transmitted.

The request contains:

- Flags
- *Inventory read* command code
- IC Manufacturer code
- AFI (if the AFI flag is set)
- Mask length
- Mask value (if mask length >0)
- First block number to be read
- Number of blocks to be read
- CRC 16

SOF	Flags	Inventory Read	IC Mfg. code	Optional AFI	Mask Length	Mask Value	First block number	Number of blocks	CRC16	EOF
	8 bits	8 bits	8 bits	8 bits	8 bits	0 – 64 bits	8 bits	8 bits	16 bits	

The `Inventory_flag` must be set to 1.

The meaning of flags 5 to 8 is according to table 5 in ISO/IEC 15693-3.

The number of blocks in the request is one less than the number of blocks that the \blacklozenge CODE SLI IC returns in its response.

Functional Specification

Standard Label IC SL2 ICS20

If the Option flag in the request is set to 0 the response contains:

SOF	Flags	Data	CRC16	EOF
	8 bits	Block Length	16 bits	
		Repeated as needed		

The I²C CODE SLI IC reads the requested block(s) and sends back their value in the response. The mechanism and timing of the *Inventory read* command performs the same as at the *Inventory* command which is described in Clause 8 of ISO/IEC 15693-3.

If the Option flag in the request is set to 1 the response contains:

SOF	Flags	Rest of UID which is not part of the mask and slot number	Data	CRC16	EOF
	8 bits	0 to 64 bit	Block Length	16 bits	
		Multiple of 8 bits	Repeated as needed		

The I²C CODE SLI IC reads the requested block(s) and sends back their value in the response. Additionally the bytes of the UID, which are not parts of the mask and the slot number in case of 16 slots, are returned. Instead of a padding with zeros up to the next byte boundary the corresponding bits of the UID are returned. The mechanism and timing of the *Inventory read* command perform the same as at the *Inventory* command which is described in Clause 8 of ISO/IEC 15693-3.

Note: The number of bits of the re-transmitted UID can be calculated as follows:

16 slots: $64 - 4 - \text{mask length rounded up to the next byte boundary}$

1 slot : $64 - \text{mask length rounded up to the next byte boundary}$

Note: If the sum of first block number and number of blocks exceeds the total available number of user blocks the number of transmitted blocks is less than the requested number of blocks, which means that the last returned block is the highest available user block, followed by the 16 bit CRC and the EOF.

Functional Specification

Standard Label IC SL2 ICS20

Example: mask length=30

Returned: $64-4-30=30$ gives 4 bytes

Byte0	Byte1	Byte2	Byte3	Byte4	Byte5	Byte6	Byte7	UID	
mask value incl. padding with zeros									transmitted by Interrogator
				returned value				transmitted by I ² C CODE SLI IC	

3.4.3.2 Fast inventory read

Command Code = A1 hex

When receiving the *fast inventory read* command the I²C CODE SLI IC behaves the same as in the *inventory read* command with the following exceptions:

The datarate in the direction I²C CODE SLI IC to the interrogator is twice as defined in ISO/IEC 15693-3 (depending on the `datarate_flag` 53 kbit/s (high datarate) or 13 kbit/s (low datarate)).

The datarate from the interrogator to the I²C CODE SLI IC and the time between the rising edge of the EOF from the interrogator to the I²C CODE SLI IC remain unchanged (stay the same as defined in ISO/IEC 15693-3).

In the direction I²C CODE SLI IC to the interrogator only the single subcarrier mode is supported.

Functional Specification

Standard Label IC SL2 ICS20

3.4.3.3 Set EAS

Command Code = A2 hex

This command sets the EAS bit to 1.

Request format

SOF	Flags	Set EAS	IC Mfg. code	UID	CRC16	EOF
	8 bits	8 bits	8 bits	64 bits	16 bits	

Response format when Error_flag is set

SOF	Flags	Error Code	CRC16	EOF
	8 bits	8 bits	16 bits	

Response format when Error_flag is NOT set

SOF	Flags	CRC16	EOF
	8 bits	16 bits	

3.4.3.4 Reset EAS

This command sets the EAS bit to 0.

Command Code = A3 hex

Request format

SOF	Flags	Reset EAS	IC Mfg. code	UID	CRC16	EOF
	8 bits	8 bits	8 bits	64 bits	16 bits	

Response format when Error_flag is set

SOF	Flags	Error Code	CRC16	EOF
	8 bits	8 bits	16 bits	

Response format when Error_flag is NOT set

SOF	Flags	CRC16	EOF
	8 bits	16 bits	

Functional Specification

Standard Label IC SL2 ICS20

3.4.3.5 Lock EAS

Command Code = A4 hex

This command locks the current state of the EAS bit.

Request format

SOF	Flags	Lock EAS	IC Mfg. code	UID	CRC16	EOF
	8 bits	8 bits	8 bits	64 bits	16 bits	

Response format when Error_flag is set

SOF	Flags	Error Code	CRC16	EOF
	8 bits	8 bits	16 bits	

Response format when Error_flag is NOT set

SOF	Flags	CRC16	EOF
	8 bits	16 bits	

3.4.3.6 EAS Alarm

Command Code = A5 hex

If the EAS bit is set to 1 the EAS response is returned from the \blacktriangleright CODE SLI IC

Request format

SOF	Flags	EAS	IC Mfg. code	UID	CRC16	EOF
	8 bits	8 bits	8 bits	64 bits	16 bits	

If an error is detected the \blacktriangleright CODE SLI IC remains silent

Response format

SOF	Flags	EAS sequence	CRC16	EOF
	8 bits	256 bits	16 bits	

Functional Specification

Standard Label IC SL2 ICS20

EAS sequence (starting with the LSB, which is transmitted first; read from left to right):

```

11110100 11001101 01000110 00001110 10101011 11100101 00001001 11111110
00010111 10001101 00000001 00011100 01001011 10000001 10010010 01101110
01000001 01011011 01011001 01100001 11110110 11110101 11010001 00001101
10001111 00111001 10001011 01001000 10100101 01001110 11101100 11110111

```

If the EAS bit is set to 0 the I²C CODE SLI IC remains silent.

3.5 Error handling

3.5.1 TRANSMISSION ERRORS

According to ISO/IEC 15693 the Label IC will not respond if a transmission error (CRC, bitcoding, bitcount, wrong framing) is detected and will silently wait for the next correct received command.

3.5.2 NOT SUPPORTED COMMANDS OR OPTIONS

If the received command or option is not supported, the behaviour of the Label IC is depending of the addressing mechanism.

3.5.2.1 Non Addressed Mode

The label IC remains silent.

3.5.2.2 Addressed or Selected Mode

The addressed or selected label IC responds with the error code "0F" hex (error with no information given or error code is not supported).

If the Inventory flag or the protocol extension flag is set the label IC will not respond if the command or option is not supported.

3.5.3 PARAMETER OUT OF RANGE

3.5.3.1 Read commands

If the sum of the first block number and the number of blocks exceeds the total available number of user blocks, the number of transmitted blocks is less than the requested number of blocks, which means that the last returned block is the highest available user block, followed by the 16 bit CRC and the EOF.

Functional Specification

Standard Label IC SL2 ICS20

3.5.3.2 *Write and lock commands*

If the address of a block to be written does not exist or a block to be written is locked the behaviour of the Label IC is depending of the addressing mechanism.

3.5.3.2.1 Non Addressed Mode

The label IC remains silent and aborts the command without writing anything.

3.5.3.2.2 Addressed or Selected Mode

The addressed or selected label IC responds with the error code "0F" hex (error with no information given or error code is not supported).

3.6 Data Integrity

Following mechanisms are implemented in the contactless communication link between interrogator and label to ensure very reliable data transmission:

- 16 bit CRC per block
- Bit count checking
- Bit coding to distinguish between "1", "0", and no information
- Channel monitoring (protocol sequence and bit stream analysis)

3.7 RF Interface

The definition of the RF-interface is according to the standard ISO/IEC 15693-2 and ISO/IEC 15693-3.

Functional Specification**Standard Label IC SL2 ICS20**

4 INLET/LABEL CHARACTERISATION AND TEST

The parameters recommended to be characterised for the inlet/label are:

Parameter	Symbol	Conditions
Resonant frequency	f_{res}	Resonant frequency @ $T_{\text{amb}} = 22\text{ °C}$ @ H_{min}
Threshold value of the field strength for <i>read single block</i> command	H_{min}	<i>Read single block</i> command OK
Threshold value of the field strength for <i>write single block</i> command	H_{write}	<i>Write single block</i> (and verifying <i>read single block</i>) command OK

To detect damage of EEPROM cells during production of inlets/labels a final test of the EEPROM after assembly of the inlet/label is recommended. This is necessary to achieve lowest failure rates.

Functional Specification

Standard Label IC SL2 ICS20

5 DEFINITIONS

Data sheet status	
Objective specification	This data sheet contains target or goal specifications for product development.
Preliminary specification	This data sheet contains preliminary data; supplementary data may be published later.
Product specification	This data sheet contains final product specifications.
Limiting values	
Limiting values given are in accordance with the Absolute Maximum Rating System (IEC 134). Stress above one or more of the limiting values may cause permanent damage to the device. These are stress ratings only and operation of the device at these or at any other conditions above those given in the Characteristics section of the specification is not implied. Exposure to limiting values for extended periods may affect device reliability.	
Application information	
Where application information is given, it is advisory and does not form part of the specification.	

6 DISCLAIMERS

6.1 Life Support Applications

These products are not designed for use in life support appliances, devices, or systems where malfunction of these products can reasonably be expected to result in personal injury. Philips customers using or selling these products for use in such applications do so on their own risk and agree to fully indemnify Philips for any damages resulting from such improper use or sale.

6.2 Licence Policy

Purchase of this Philips IC with a functionally according to ISO/IEC 15693 Standard does not convey an implied license under any patent right on this standard. A license for the Philips portfolio of patents on the ISO/IEC 15693 Standard can be obtained via the Philips Intellectual Property and Standards department. For more information please contact the nearest Philips Semiconductors sales office.

Functional Specification**Standard Label IC SL2 ICS20****7 REVISION HISTORY****Table 1** Functional Specification SL2 ICS20 Revision History

REVISION	DATE	CPCN	PAGE	DESCRIPTION
1.0	Nov. 2000			Initial version.
1.1	August 2001			First update, correction of errors.
1.2	Sept. 2001			Second update, correction of errors.
1.3	Nov. 2001			Third update, correction of errors
1.4	March 2002			Changed security status of the document
2.0	June 2002			Preliminary Specification; licence policy added
3.0	Jan. 2003			Product Specification
3.1	Jan. 2005		11	Note regarding EAS status added

Functional Specification

Standard Label IC SL2 ICS20

NOTES

Philips Semiconductors - a worldwide company

Contact Information

For additional information please visit **<http://www.semiconductors.philips.com>**. Fax: **+31 40 27 24825**
For sales offices addresses send e-mail to: **sales.addresses@www.semiconductors.philips.com**.

© Koninklijke Philips Electronics N.V. 2002

SCA74

All rights are reserved. Reproduction in whole or in part is prohibited without the prior written consent of the copyright owner.

The information presented in this document does not form part of any quotation or contract, is believed to be accurate and reliable and may be changed without any notice. No liability will be accepted by the publisher for any consequence of its use. Publication thereof does not convey nor imply any license under patent- or other industrial or intellectual property rights.

**Philips
Semiconductors**



PHILIPS

Mouser Electronics

Authorized Distributor

Click to View Pricing, Inventory, Delivery & Lifecycle Information:

[NXP:](#)

[SL2ICS2001DW/V1D,3](#)