



TDA8296

Digital global standard low IF demodulator for analog TV and FM radio

Rev. 1 — 3 March 2011

Product data sheet

1. General description

The TDA8296 is an alignment-free digital multistandard vision and sound low IF signal PLL demodulator for positive and negative video modulation including AM and FM mono sound processing. It can be used in all countries worldwide for M/N, B/G/H, I, D/K, L and L-accent standard. CVBS and SSIF/mono audio are provided via two DACs. FM radio preprocessing is included for simple interfacing with demodulator/stereo decoder backends.

The IC is especially suited for the application with the NXP Silicon Tuner TDA1827x.

All the processing is done in the digital domain.

The chip has an 'easy programming' mode to make the I²C-bus protocol very simple. In principle, only one bit sets the proper standard with recommended content. However, if this is not suitable, free programming is always possible.

Note: Register 06h has to be reprogrammed to new value C4h (see [Section 9.2](#) and [Section 9.3.1](#)).

2. Features and benefits

- Digital IF demodulation for all analog TV standards worldwide (M/N, B/G/H, D/K, I, L and L-accent standard)
- Multistandard true synchronous demodulation with active carrier regeneration
- Alignment-free
- 16 MHz typical reference frequency input (from low IF tuner) or operating as crystal oscillator
- Internal PLL synthesizer which allows the use of a low-cost crystal (typically 16 MHz)
- Especially suited for the NXP Silicon Tuner TDA1827x
- No SAW filter needed
- Low application effort and external component count in combination with the TDA1827x
- Simple upgrade of TDA8295 possible
- 12-bit low power IF ADC on chip running with 54 MHz or 27 MHz
- Two 10-bit DACs on chip for CVBS and SSIF or audio
- Easy programming for I²C-bus
- High flexibility due to various I²C-bus programming registers
- I²C-bus interface and I²C-bus feed-through for tuner programming
- Four I²C-bus addresses selectable via two external pins



- Gated IF AGC acting on black level by using H/V PLL or peak IF AGC (I²C-bus selectable)
- Internal digital logarithmic IF AGC amplifier with up to 48 dB gain and 68 dB control range
- Peak search tuner IF AGC for optimal adaptive drive of the IF ADC
- Switchable IF PLL and IF AGC loop bandwidths
- Precise AFC and lock detector
- Accurate group delay equalization for all standards
- Very robust IF demodulator coping with adverse field conditions
- Wide PLL pull-in range up to $\pm 1\,660$ kHz (I²C-bus selectable)
- CVBS and SSIF or audio output with simple postfilter (capacitor only)
- CVBS gain levelling stage to provide nearly constant signal amplitude during over modulation
- Video equalizer with eight settings
- Nyquist filter in video baseband
- Excellent video S/N (typically 60 dB weighted)
- High selectivity video low-pass filter for all standards
- Low video into sound crosstalk
- SSIF AGC
- Sound performance comparable to QSS single reference concepts
- AM/FM mono sound demodulator
- Switchable de-emphasis
- Excellent FM sound
- Good AM sound
- High FM Deviation mode for China
- Preprocessing of FM radio (mono and stereo) with highly selective digital band-pass filter
- No ceramic filter or external components needed for FM radio
- FM radio available in mono
- Automatic or forced mute for mono sound
- Automatic or forced blank for video
- Mostly digital FIR filter implementation (NSC notches and video low-pass filters)
- Three GPIO pins
- Power-On Reset (POR) block for reliable power-up behavior
- Very low total power dissipation (typically 150 mW)
- No power sequence requirement
- Standby mode (typically 5 mW)
- 40-pin HVQFN package
- CMOS technology (0.090 μ m 1.2 V and 3.3 V)

3. Applications

- TV applications
- Recording
- PC TV applications

4. Quick reference data

Table 1. Quick reference data

Power supplies 3.3 V, 1.2 V; $T_{amb} = 25\text{ °C}$; PC/SC1 for L and M = 10 dB, all others 13 dB; nominal residual picture carrier of 3 % for L/L', 10 % for M, 10 % for B/G, 12.5 % for D/K, 20 % for I; FM/AM modulation = 54 %, 1 kHz modulation frequency; measured in application PCB (see [Figure 22](#) and [Figure 23](#)) with 16 MHz crystal frequency, terminated with 75 Ω (CVBS) and 1 k Ω (SSIF/audio). Operation mode set via easy programming ([Section 9.3.1](#)), otherwise stated. Low IF input signal at -3dB full scale, input frequencies as defined under row header IF input.

Symbol	Parameter	Conditions	Min	Typ	Max	Unit
Power supply						
$V_{DD(1V2)}$	supply voltage (1.2 V)	digital and analog	1.1	1.2	1.3	V
$V_{DD(3V3)}$	supply voltage (3.3 V)	digital and analog	3.0	3.3	3.6	V
$I_{DD(tot)(1V2)}$	total supply current (1.2 V)		-	49	-	mA
$I_{DD(tot)(3V3)}$	total supply current (3.3 V)		-	65	-	mA
P_{tot}	total power dissipation	default settings; $f_s = 54\text{ MHz}$ at ADC; DAC application in accordance to Figure 23	-	270	-	mW
		$f_s = 54\text{ MHz}$ at ADC; DAC application in accordance to Figure 24	-	150	-	mW
		Standby mode	-	5	8	mW
IF input						
$V_{i(p-p)}$	peak-to-peak input voltage	for full-scale ADC input (0 dBFS)	0.7	0.8	0.9	V
V_i	input voltage	operational input related to ADC full scale; all standards; sum of all signals	-3	-3	-3	dBFS
f_i	input frequency	PC / SC1				
		M/N standard	-	5.40 / 0.90	-	MHz
		B standard	-	6.40 / 0.90	-	MHz
		G/H standard	-	6.75 / 1.25	-	MHz
		I standard	-	7.25 / 1.25	-	MHz
		D/K standard	-	6.85 / 0.35	-	MHz
		L standard	-	6.75 / 0.25	-	MHz
		L-accent standard	-	1.25 / 7.75	-	MHz
		FM radio	-	1.25	-	MHz
Carrier recovery FPLL						
$B_{-3dB(cl)}$	closed-loop -3 dB bandwidth	wide	-	60	-	kHz
Δf_{pullin}	pull-in frequency range		11	± 830	-	kHz
$m_{over(PC)}$	picture carrier over modulation index	black for L/L-accent standard; flat field white else	115	117	-	%
IF demodulation (video equalizer in Flat mode)						
$\alpha_{sup(stpb)}$	stop-band suppression	video low-pass filter (M/N, B/G/H, I, D/K, L/L-accent standard)	-	-60	-	dB
$t_{ripple(GDE)}$	group delay equalizer ripple time	peak value for B/G/H half, D/K half, I flat, M (FCC) full, L/L-accent full standard	-	20	40	ns

Table 1. Quick reference data ...continued

Power supplies 3.3 V, 1.2 V; $T_{amb} = 25\text{ }^{\circ}\text{C}$; PC/SC1 for L and M = 10 dB, all others 13 dB; nominal residual picture carrier of 3 % for L/L', 10 % for M, 10 % for B/G, 12.5 % for D/K, 20 % for I; FM/AM modulation = 54 %, 1 kHz modulation frequency; measured in application PCB (see [Figure 22](#) and [Figure 23](#)) with 16 MHz crystal frequency, terminated with 75 Ω (CVBS) and 1 k Ω (SSIF/audio). Operation mode set via easy programming ([Section 9.3.1](#)), otherwise stated. Low IF input signal at -3dB full scale, input frequencies as defined under row header IF input.

Symbol	Parameter	Conditions	Min	Typ	Max	Unit
CVBS output						
$V_{o(p-p)}$	peak-to-peak output voltage	negative PC modulation (all standards except L/L-accent); 75 Ω DC load; sync-white modulation; 90 % (nominal)	0.9	1.0	1.1	V
		positive PC modulation (L/L-accent standard); 75 Ω DC load; sync-white modulation; 97 % (nominal)	0.9	1.0	1.1	V
$B_{video(-3dB)}$	-3 dB video bandwidth	overall video response; CVBS equalizer flat				
		all standards except M/N	4.7	4.85	-	MHz
		M/N standard	3.8	3.9	-	MHz
$\alpha_{resp(f)}$	frequency response	video equalizer; 8 equally spaced settings; value at 3.9 MHz	-5	-	+4.5	dB
G_{dif}	differential gain	"ITU-T J.63 line 330"	-	1.5	5	%
φ_{dif}	differential phase	"ITU-T J.63 line 330"	-	1.0	3	deg
$(S/N)_w$	weighted signal-to-noise ratio	all standards; unified weighting filter ("ITU-T J.61"); PC at -6 dBFS	57	60	-	dB
SSIF/mono sound output						
$V_{o(SSIF)(RMS)}$	RMS SSIF output voltage	1 k Ω DC or AC load; no modulation; PC / SC1 = 13 dB				
		M standard	105	115	127	mV
		B standard	97	104	116	mV
		G/H standard	97	104	116	mV
		D/K standard	89	96	106	mV
		I standard	93	100	111	mV
		L standard	89	96	106	mV
		L-accent standard	89	96	106	mV
		FM radio (single carrier)	94	103	115	mV
$V_{o(AF)(RMS)}$	RMS AF output voltage	1 k Ω DC or AC load				
		M standard; 54 % modulation degree (± 13.5 kHz FM deviation before pre-emphasis)	98	116	135	mV
		B, G/H, I, D/K standard; 54 % modulation degree (± 27 kHz FM deviation before pre-emphasis)	107	126	144	mV
$\alpha_{hr(AF)}$	AF headroom	before clipping; 1 k Ω DC or AC load				
		M standard; related to ± 25 kHz peak deviation before pre-emphasis	-	7	-	dB
		B, G/H, I, D/K standard; related to ± 50 kHz peak deviation before pre-emphasis	-	7	-	dB

Table 1. Quick reference data ...continued

Power supplies 3.3 V, 1.2 V; $T_{amb} = 25\text{ °C}$; PC/SC1 for L and M = 10 dB, all others 13 dB; nominal residual picture carrier of 3 % for L/L', 10 % for M, 10 % for B/G, 12.5 % for D/K, 20 % for I; FM/AM modulation = 54 %, 1 kHz modulation frequency; measured in application PCB (see [Figure 22](#) and [Figure 23](#)) with 16 MHz crystal frequency, terminated with 75 Ω (CVBS) and 1 k Ω (SSIF/audio). Operation mode set via easy programming ([Section 9.3.1](#)), otherwise stated. Low IF input signal at -3dB full scale, input frequencies as defined under row header IF input.

Symbol	Parameter	Conditions	Min	Typ	Max	Unit
THD	total harmonic distortion	FM; for 50 kHz deviation before pre-emphasis (25 kHz for M standard)	-	0.15	0.3	%
		AM; m = 80 %	-	0.5	1	%
$B_{AF(-3dB)}$	-3 dB AF bandwidth	AM	20	27	-	kHz
		FM	40	50	-	kHz
$(S/N)_{w(AF)}$	AF weighted signal-to-noise ratio	via internal mono sound demodulator; "ITU-R BS.468-4"; FM mode related to 27 kHz deviation before pre-emphasis; 10 % residual PC; SC1; color bar picture	52	54	-	dB
		via internal mono sound demodulator; [2] (audio gain +6 dB) "ITU-R BS.468-4"; AM; m = 54 %; 3 % residual PC; SC1; color bar picture	40	44	-	dB

[1] The pull-in range can be doubled to $\pm 1\,660$ kHz by I²C-bus register like described in [Table 16](#). Then the AFC read-out has 256 steps.

[2] To set audio gain to +6 dB for internal sound demodulation, register 22h has to be programmed to 08h.

5. Ordering information

Table 2. Ordering information

Type number	Package		Version
	Name	Description	
TDA8296HN	HVQFN40	plastic thermal enhanced very thin quad flat package; no leads; 40 terminals; body 6 × 6 × 0.85 mm	SOT618-1

6. Functional diagram

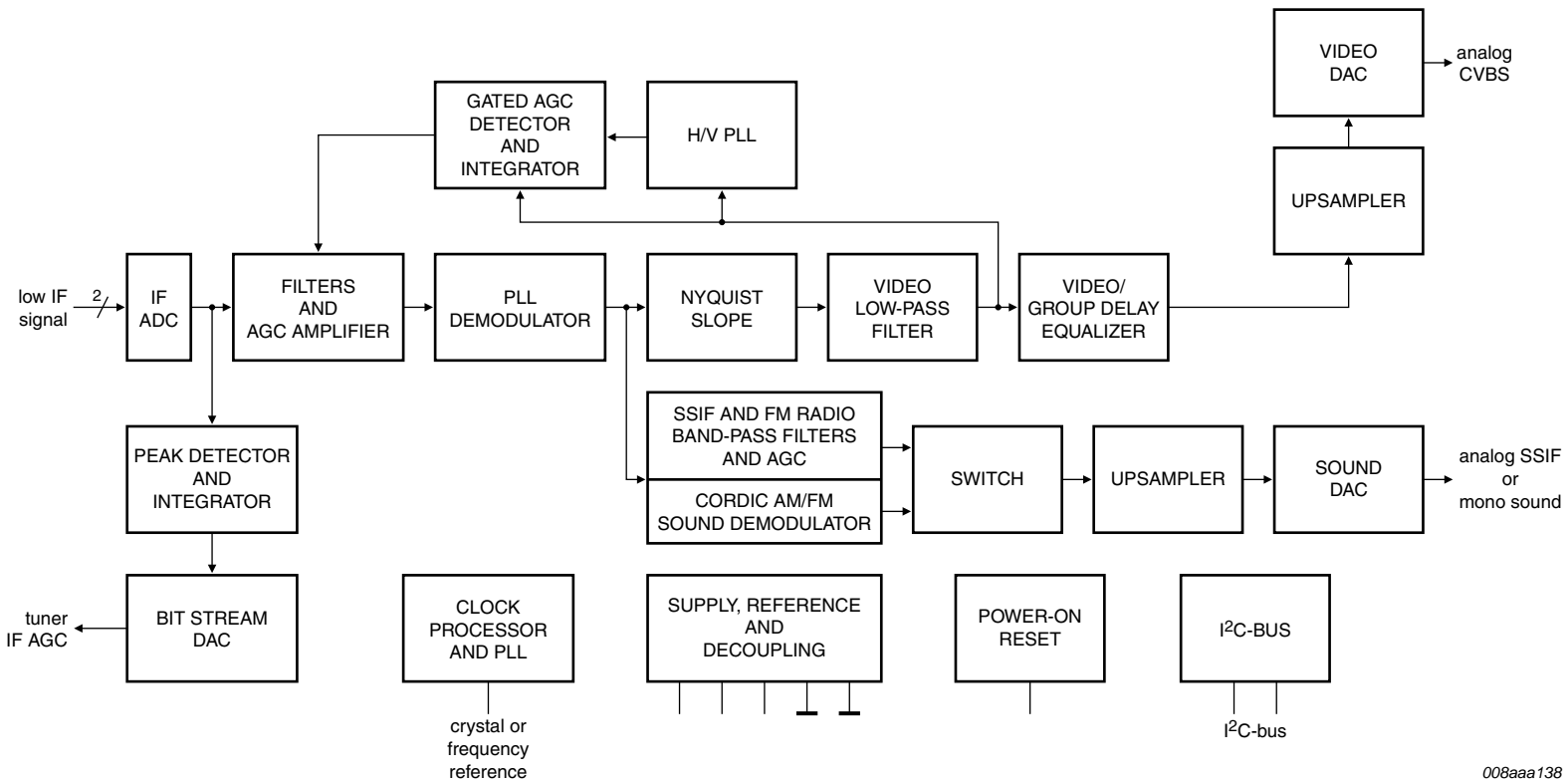

008aaa138

Fig 1. Functional diagram of TDA8296

7. Pinning information

7.1 Pinning

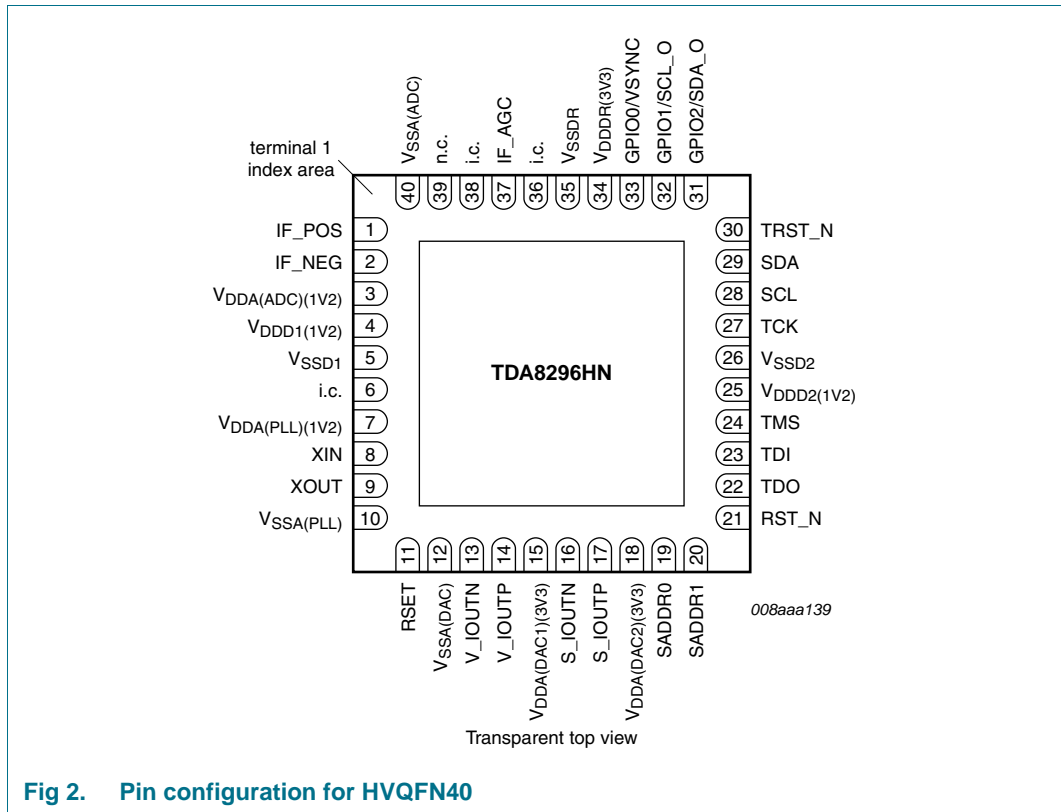

Fig 2. Pin configuration for HVQFN40

Table 3. Pin allocation table

Pin	Symbol	Pin	Symbol
1	IF_POS	2	IF_NEG
3	V _{DDA(ADC)} (1V2)	4	V _{DD1} (1V2)
5	V _{SSD1}	6	i.c.
7	V _{DDA(PLL)} (1V2)	8	XIN
9	XOUT	10	V _{SSA(PLL)}
11	RSET	12	V _{SSA(DAC)}
13	V_IOUTN	14	V_IOUTP
15	V _{DDA(DAC1)} (3V3)	16	S_IOUTN
17	S_IOUTP	18	V _{DDA(DAC2)} (3V3)
19	SADDR0	20	SADDR1
21	RST_N	22	TDO
23	TDI	24	TMS
25	V _{DD2} (1V2)	26	V _{SSD2}
27	TCK	28	SCL
29	SDA	30	TRST_N

Table 3. Pin allocation table ...continued

Pin	Symbol	Pin	Symbol
31	GPIO2/SDA_O	32	GPIO1/SCL_O
33	GPIO0/VSYN	34	V _{DDDR(3V3)}
35	V _{SSDR}	36	i.c.
37	IF_AGC	38	i.c.
39	n.c.	40	V _{SSA(ADC)}
die pad	global ground at backside contact		

7.2 Pin description

Table 4. Pin description

Symbol	Pin	Type ^[1]	Description
Reset			
RST_N	21	I	The RST_N input is asynchronous and active LOW, and clears the TDA8296. When RST_N goes LOW, the circuit immediately enters its Reset mode and normal operation will resume four XIN signal falling edges later after RST_N returns HIGH. Internal register contents are all initialized to their default values. The minimum width of RST_N at LOW level is four XIN clock periods.
Reference			
XIN	8	I	Crystal oscillator input pin. In Slave mode (typically), the XIN input simply receives a 16 MHz clock signal (f_{REF}) from an external device (typically from the TDA1827x). In Oscillator mode, a fundamental 16 MHz (typically) crystal is connected between pin XIN and pin XOUT.
XOUT	9	O	Crystal oscillator output pin. In Slave mode, the XOUT output is not connected. In Oscillator mode a fundamental 16 MHz (typically) crystal is connected between pin XIN and pin XOUT.
I²C-bus			
SDA	29	I/O, OD	I ² C-bus bidirectional serial data. SDA is an open-drain output and therefore requires an external pull-up resistor (typically 4.7 k Ω).
SCL	28	I	I ² C-bus clock input. SCL is nominally a square wave with a maximum frequency of 400 kHz. It is generated by the system I ² C-bus master.
SADDR0	19	I	These two bits allow to select four possible I ² C-bus addresses, and therefore permits to use several TDA8296 in the same application and/or to avoid conflict with other ICs. The complete I ² C-bus address is: 1, 0, 0, SADDR1, 0, 1, SADDR0, R/W (see also Section 9.1).
SADDR1	20	I	
I²C-bus feed-through switch or GPIO			
GPIO2/SDA_O	31	I/O, OD	SDA_O is equivalent to SDA but can be 3-stated by I ² C-bus programming. It is the output of a switch controlled by I2CSW_EN parameter. SDA_O is an open-drain output and therefore requires an external pull-up resistor (see Section 9.3.18).
GPIO1/SCL_O	32	I/O, OD	SCL_O is equivalent to SCL input but can be 3-stated by I ² C-bus programming. SCL_O is an open-drain output and therefore requires an external pull-up resistor (see Section 9.3.18). For proper functioning of the I ² C-bus feed-through, a capacitor C = 33 pF to GND must be added (see Section 13.6).
V-sync or GPIO			
GPIO0/VSYN	33	I/O, OD	vertical synchronization pulse needed for the NXP Silicon Tuner (see Section 9.3.18)
Tuner IF AGC			
IF_AGC	37	I/O, OD, T	tuner IF AGC output

Table 4. Pin description ...continued

Symbol	Pin	Type ^[1]	Description
Boundary scan			
TMS	24	I	Test mode select provides the logic levels needed to change the TAP controller from state to state during the boundary scan test.
TRST_N	30	I	Test reset is used to reset the TAP controller (active LOW). Grounding is mandatory in Functional mode.
TCK	27	I	Test clock is used to drive the TAP controller.
TDI	23	I	Test data input is the serial data input for the test data instruction.
TDO	22	O	Test data output is the serial test data output pin. The data is provided on the falling edge of TCK.
ADC			
IF_POS	1	AI	IF positive analog input for internal ADC
IF_NEG	2	AI	IF negative analog input for internal ADC
DAC			
V_IOUTP	14	AO	positive analog current output of the video output
V_IOUTN	13	AO	negative analog current output of the video output
S_IOUTP	17	AO	positive analog current output of the SSIF/mono sound output
S_IOUTN	16	AO	negative analog current output of the SSIF/mono sound output
RSET	11	I	External bias setting of the DACs. An external resistor (1 kΩ typical) has to be connected between RSET and the analog ground of the board. This resistor generates the current into the DACs and also defines the full scale output current. The total parasitic capacitance seen externally from the RSET pin has to be lower than 20 pF.
Supplies and grounds			
V _{DDA(DAC1)(3V3)}	15	PS	DAC1 (video DAC) and DAC reference module analog supply voltage (3.3 V typical)
V _{DDA(DAC2)(3V3)}	18	PS	DAC2 (sound DAC) analog supply voltage (3.3 V typical)
V _{SSA(DAC)}	12	GND	DAC reference module analog ground supply voltage (0 V typical)
V _{DDA(ADC)(1V2)}	3	PS	IF ADC analog supply voltage (1.2 V typical)
V _{SSA(ADC)}	40	GND	ADC analog ground supply voltage (0 V typical)
V _{DDD1(1V2)}	4	PS	ADC, PLL and DACs digital supply voltage (1.2 V typical)
V _{SSD1}	5	GND	ADC, PLL and DACs digital ground supply voltage (0 V typical)
V _{DDA(PLL)(1V2)}	7	PS	crystal oscillator and clock PLL analog supply voltage (1.2 V typical)
V _{SSA(PLL)}	10	GND	crystal oscillator and clock PLL analog ground supply voltage (0 V typical)
V _{DDD2(1V2)}	25	PS	core digital supply voltage (1.2 V typical)
V _{SSD2}	26	GND	core digital ground supply voltage (0 V typical)
V _{DDDR(3V3)}	34	PS	ring digital supply voltage (3.3 V typical)
V _{SSDR}	35	GND	ring digital ground supply voltage (0 V typical)
V _{SS}	die pad	GND	
Other pins			
i.c.	6, 36, 38	I	internally connected; connect to ground
n.c.	39	I	not connected

[1] The pin types are defined in [Table 5](#).

Table 5. Pin type description

Type	Description
AI	analog input
AO	analog output
GND	ground
I	digital input
I/O	digital input and output
O	digital output
OD	open-drain output
PS	power supply
T	3-state

8. Functional description

8.1 IF ADC

The low IF spectrum (1 MHz to 10 MHz) from the Silicon Tuner TDA1827x is fed symmetrically to the 12-bit IF ADC of the TDA8296, where it is sampled with 54 MHz or 27 MHz. All the anti-aliasing filtering is already done in the Silicon Tuner.

8.2 Filters

The internal filters permit to reduce the sampling rate to 13.5 MHz, and to form a complex signal to ease the effort of further signal processing. Before this, the DC offset (coming from the ADC) is removed.

In addition, standard dependent notch filters for the adjacent sound carriers protect the picture carrier PLL from malfunctioning and avoid disturbances (i.e. moire) becoming visible in the video output.

8.3 PLL demodulator

The second-order PLL is the core block of the whole IC. It is very robust against adverse field conditions, like excessive over modulation, no residual carrier presence or unwanted phase or frequency modulation of the picture carrier. The PLL output is the synchronously demodulated channel.

The AFC data is available via the I²C-bus.

8.4 Nyquist filter, video low-pass filter, video and group delay equalizer, video leveling

The afore-mentioned down-mixed complex signal at the mixer CORDIC output, already consisting of the demodulated content of the picture carrier together with the sound carriers (the so-called intercarriers), is running through a Nyquist filter to get a flat video response and is made real.

Afterwards, a video low-pass filter suppresses the sound carriers and other disturbers.

Next comes the equalizer circuit to remove the transmitter group delay predistortion.

A video leveling stage follows, which brings the output within the SCART specification (± 3 dB overall), despite heavy over modulation. The response time is made very slow.

Finally, a video equalizer allows to compensate the perhaps non-flat frequency response from the tuner or to change the overall video response according to customer wish (i.e. peaking or early roll-off).

8.5 Upsampler and video DAC

The filtered and compensated CVBS signal is connected to the oversampled 10-bit video DAC ($f_s = 108$ MHz) via an interpolation stage. The strong oversampling replaces a former complicated LCR postfiltering by a simple first-order RC low-pass filter to remove the DAC image frequencies sufficiently. This holds also for the sound DAC, described in [Section 8.6](#).

8.6 SSIF/mono sound processing

The complex signal is routed via a band-pass, AGC and interpolation filter to the 10-bit sound DAC for the recovery of the second sound carriers (SSIF). A very sharp band-pass filter at 5.5 MHz is added in the FM Radio mode to remove neighbor channels. This also eases the dynamic burden on the following ADC in the demodulator/decoder chip. The afore-mentioned high-selectivity band-pass, which replaces the former ceramic filter, is located behind a frequency shifter. In there, the incoming wanted FM radio channel from the Silicon Tuner is changed from 1.25 MHz to 5.5 MHz.

Moreover, the complex signal is demodulated in a linear CORDIC detector and low-pass filtered to attenuate the video spectrum and the second sound carrier, respectively other disturbers above the intercarrier. The output of the linear CORDIC (phase information) is differentiated for getting the demodulated FM audio. The AM demodulation is executed in a synchronous fashion by using a narrow-band PLL demodulator.

A de-emphasis filter is implemented for FM standards, before the audio is interpolated to 108 MHz as in the CVBS case.

The mono audio is made available in the sound DAC via an I²C-bus controlled selector in case the intercarrier path is not used for driving an external stereo demodulator.

However, if the mono audio output has to meet the SCART specification, an external cheap operational amplifier with 12 dB gain becomes necessary, because the low supply voltage for the TDA8296 doesn't allow such high levels like 2 V (RMS) maximum.

8.7 Tuner IF AGC

This AGC controls the tuner IF AGC amplifier in the TDA1827x in such a way, that the IF ADC is always running with a permanent headroom of 3 dB for the sum of all signals present at the ADC input. This ensures an always optimal exploitation of the dynamic range in the IF ADC.

The detection is done in peak Search mode during a field period. The attack time is made much faster than the decay time in order to avoid transient clipping effects in the IF ADC. This can happen during channel change or airplane flutter conditions.

The above wideband, slowly acting AGC loop (uncorrelated) is of first-order integral action. It is closed via the continuous tuner IF AGC amplifier in the Silicon Tuner via a bit stream DAC (PWM signal at 13.5 MHz, 27 MHz or 54 MHz) and an external and uncritical first-order RC low-pass.

8.8 Digital IF AGC

Common to both IF AGC concepts is the peak search algorithm as long as the H/V PLL is not locked. This is of advantage for the acquisition by avoiding hang-ups due to excessive overloading, so being able to leave the saturated condition by reducing the gain.

Two Detection modes are made available in the IC via I²C-bus.

- Black level gated AGC:

The first mode uses an IF AGC detector which is gated with a very robust and well-proven H/V sync PLL block on board. Gating occurs on the black level (most of the time on the back porch) of the video signal and the control is delivered after an error integration and exponential weighting to the internal IF AGC amplifier. This IF AGC amplifier, in fact a multiplier, has a control range of -20 dB to +48 dB.

- Peak AGC:

A fast attack and slow decay action cares for a good and nearly clip-free transient behavior. This proved to be more robust for non-standard signals, like sync clipping along the transmitter/receiver chain.

With respect to the IF AGC speed generally, only the gated black level or peak sync digital IF AGC can be made fast. However the peak search tuner IF AGC, used for positive modulation standards (L and L-accent standard), is rather slow because the VITS is present only once in a field.

The correlated or narrow-band AGC loop, closed via the continuous IF AGC amplifier in the TDA8296, is of first-order integral action and settles at a constant IF input level with a permanent headroom of 12 dB (picture carrier). This headroom is needed for the own sound carriers and the leaking neighbor (N - 1) spectrum.

8.9 Clock generation

Finally, either an external reference frequency (i.e. from the Silicon Tuner) or an own on-chip crystal oscillator in the TDA8296 feeds the internal PLL synthesizer to generate the necessary clock signals.

9. I²C-bus control

9.1 Protocol of the I²C-bus serial interface

The TDA8296 internal registers are accessible by means of the I²C-bus serial interface. The SDA bidirectional pin is used as the data input/output pin and SCL as the clock input pin. The highest SCL speed is 400 kHz.

9.1.1 Write mode

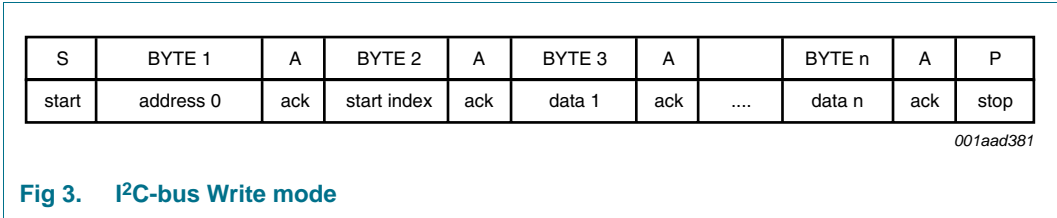
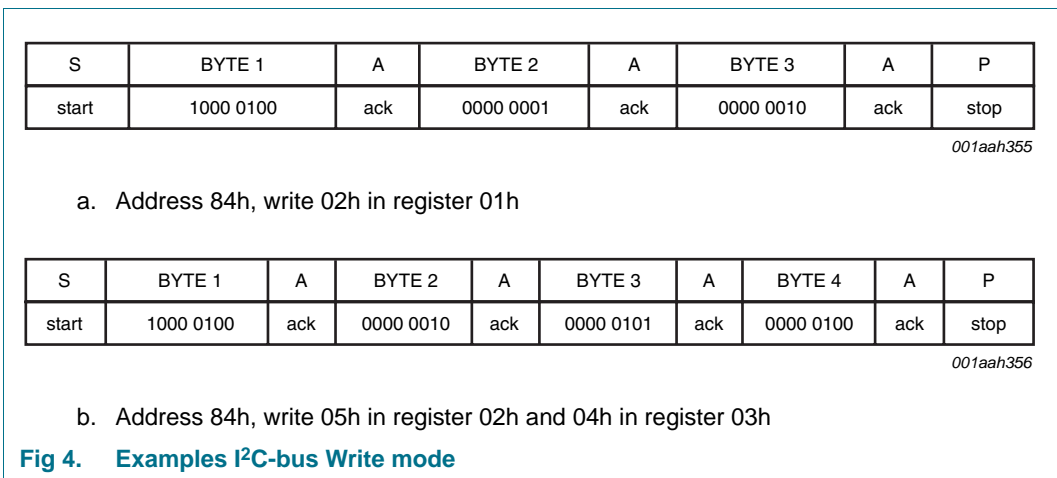

Table 6. Address format

7	6	5	4	3	2	1	0
1	0	0	SADDR1	0	1	SADDR0	R/W

Table 7. I²C-bus transfer description

Field	Bit	Description	
S	-	START condition	
Byte 1	7 to 5	device address	
	4	SADDR1	
	3 and 2	device address	
	1	SADDR0	
	0	R/W = 0 for write action	
A	-	acknowledge	
Byte 2	7 to 0	start index	
	A	-	acknowledge
	Byte 3	7 to 0	data 1
		A	-
	:		
Byte n	7 to 0	data n	
	A	-	acknowledge
P	-	STOP condition	



9.1.2 Read mode

S	BYTE 1	A	BYTE 2	A	S	BYTE 3	A	BYTE 4	A		BYTE n	A	P
start	address 0	ack	start index	ack	start	address 1	ack	value 1	ack	value n	ack	stop

001aad423

Fig 5. I²C-bus Read mode

Table 8. I²C-bus transfer description

Field	Bit	Description
S	-	START condition
Byte 1	7 to 5	device address
	4	SADDR1
	3 and 2	device address
	1	SADDR0
	0	R/W = 0 for write action
A	-	acknowledge
Byte 2	7 to 0	start index
A	-	acknowledge
S	-	START condition (without stop before)
Byte 3	7 to 5	device address
	4	SADDR1
	3 and 2	device address
	1	SADDR0
	0	R/W = 1 for read action
A	-	acknowledge
Byte 4	7 to 0	value 1
A	-	acknowledge
:		
Byte n	7 to 0	value n
A	-	acknowledge
P	-	STOP condition

S	BYTE 1	A	BYTE 2	A	S	BYTE 3	A	BYTE 4	A	BYTE 5	A	P
start	1000 0100	ack	0000 0010	ack	start	1000 0101	ack	0000 0101	ack	0000 0100	ack	stop

001aah357

Address 84h, read register 02h with value 05h and read register 03h with value 04h

Fig 6. Example I²C-bus Read mode

9.2 Register overview

The TDA8296 internal registers are accessible by means of the I²C-bus serial interface as described in [Section 9.1](#). In [Table 10](#) and [Table 9](#) an overview of all the registers is given, the register description can be found in [Section 9.3](#).

Table 9. I²C-bus register reference

Index	Name	I ² C-bus access	Default value	Reference
00h	STANDARD	R/W	01h	Table 11
01h	EASY_PROG	R/W	00h	Table 12
02h	DIV_FUNC	R/W	04h	Table 14
03h	ADC_HEADR	R/W	01h	Table 15
04h	PC_PLL_FUNC	R/W	24h	Table 16
05h	SSIF_MUTE	R/W	04h	Table 33
06h	reserved	R/W	48h ^[1]	-
07h	reserved	R/W	84h ^[1]	-
08h	reserved	R/W	08h ^[1]	-
09h	DTO_PC_LOW	R/W	9Ah	Table 17
0Ah	DTO_PC_MID	R/W	99h	Table 17
0Bh	DTO_PC_HIGH	R/W	99h	Table 17
0Ch	DTO_SC_LOW	R/W	3Dh	Table 19
0Dh	DTO_SC_MID	R/W	20h	Table 19
0Eh	DTO_SC_HIGH	R/W	59h	Table 19
0Fh	FILTERS_1	R/W	21h	Table 21
10h	FILTERS_2	R/W	31h	Table 22
11h	GRP_DELAY	R/W	01h	Table 23
12h	D_IF_AGC_SET_1	R/W	A0h	Table 24
13h	D_IF_AGC_SET_2	R/W	90h	Table 25
14h	reserved	R/W	67h ^[1]	-
15h	T_IF_AGC_SET	R/W	88h	Table 26
16h	T_IF_AGC_LIM	R/W	F0h	Table 27
17h	T_IF_AGC_FORCE	R/W	3Fh	Table 28
18h	reserved	R/W	02h ^[1]	-
19h	reserved	R/W	88h ^[1]	-
1Ah	reserved	R/W	80h ^[1]	-
1Bh	reserved	R/W	00h ^[1]	-
1Ch	V_SYNC_DEL	R/W	6Fh	Table 29
1Dh	CVBS_SET	R/W	31h	Table 30
1Eh	CVBS_LEVEL	R/W	73h	Table 31
1Fh	CVBS_EQ	R/W	10h	Table 32
20h	SOUNDSET_1	R/W	21h	Table 34
21h	SOUNDSET_2	R/W	22h	Table 35
22h	SOUND_LEVEL	R/W	08h	Table 36
23h	SSIF_LEVEL	R/W	AFh	Table 37

Table 9. I²C-bus register reference ...continued

Index	Name	I ² C-bus access	Default value	Reference
24h	ADC_SAT	R	-	Table 38
25h	AFC	R	-	Table 39
26h	HVPLL_STAT	R	-	Table 41
27h	D_IF_AGC_STAT	R	-	Table 42
28h	T_IF_AGC_STAT	R	-	Table 43
29h	reserved	R	-	-
2Ah	reserved	R/W	00h ^[1]	-
2Bh	ALT_FILT_COEF	R/W	00h ^[1]	Table 44
2Ch	reserved	R	-	-
2Dh	SSIF_AGC_STAT_REG	R	-	Table 45
2Eh	not used	R/W	00h	-
2Fh	IDENTITY	R	-	Table 46
30h	CLB_STDBY	R/W	01h	Table 47
31h	reserved	R/W	00h ^[1]	-
32h	reserved	R	-	-
33h	ADC_CTL	R/W	24h	Table 48
34h	ADC_CTL_2	R/W	05h	Table 49
35h	VIDEODAC_CTL	R/W	7Eh	Table 50
36h	AUDIODAC_CTL	R/W	00h	Table 51
37h	DAC_REF_CLK_CTL	R/W	40h	Table 52
38h	reserved	R/W	20h ^[1]	-
39h to 3Bh	not used	R/W	00h	-
3Ch	reserved	R/W	00h ^[1]	-
3Dh	not used	R/W	00h	-
3Eh	reserved	R/W	61h ^[1]	-
3Fh	PLL_REG07	R/W	00h	Table 53
40h	PLL_REG08	R/W	1Ah	Table 53
41h	PLL_REG09	R/W	02h	Table 53
42h	PLL_REG10	R/W	01h	Table 53
43h	reserved	R/W	00h ^[1]	-
44h	GPIOREG_0	R/W	1Bh	Table 54
45h	GPIOREG_1	R/W	C1h	Table 55
46h	GPIOREG_2	R/W	07h	Table 57
47h to 4Ah	reserved	R	-	-
4Bh	GD_EQ_SECT1_C1	R/W	00h	Table 58
4Ch	GD_EQ_SECT1_C2	R/W	00h	Table 58
4Dh	GD_EQ_SECT2_C1	R/W	00h	Table 58
4Eh	GD_EQ_SECT2_C2	R/W	00h	Table 58
4Fh	GD_EQ_SECT3_C1	R/W	00h	Table 58
50h	GD_EQ_SECT3_C2	R/W	00h	Table 58
51h	GD_EQ_SECT4_C1	R/W	00h	Table 58

Table 9. I²C-bus register reference ...continued

Index	Name	I ² C-bus access	Default value	Reference
52h	GD_EQ_SECT4_C2	R/W	00h	Table 58
53h to 56h	not used	R/W	00h	-
57h	CVBS_EQ_COEF0_LOW	R/W	00h	Table 60
58h	CVBS_EQ_COEF0_HIGH	R/W	00h	Table 60
59h	CVBS_EQ_COEF1_LOW	R/W	00h	Table 60
5Ah	CVBS_EQ_COEF1_HIGH	R/W	00h	Table 60
5Bh	CVBS_EQ_COEF2_LOW	R/W	00h	Table 60
5Ch	CVBS_EQ_COEF2_HIGH	R/W	00h	Table 60
5Dh	CVBS_EQ_COEF3_LOW	R/W	00h	Table 60
5Eh	CVBS_EQ_COEF3_HIGH	R/W	00h	Table 60
5Fh	CVBS_EQ_COEF4_LOW	R/W	00h	Table 60
60h	CVBS_EQ_COEF4_HIGH	R/W	00h	Table 60
61h	CVBS_EQ_COEF5_LOW	R/W	00h	Table 60
62h	CVBS_EQ_COEF5_HIGH	R/W	04h	Table 60
63h to 66h	not used	R/W	00h	-
67h	reserved	R/W	Fh ^[1]	-
68h	reserved	R/W	0Fh ^[1]	-
69h	reserved	R/W	FAh ^[1]	-
6Ah	reserved	R/W	0Fh ^[1]	-
6Bh	reserved	R/W	EFh ^[1]	-
6Ch	reserved	R/W	0Fh ^[1]	-
6Dh	reserved	R/W	DDh ^[1]	-
6Eh	reserved	R/W	0Fh ^[1]	-
6Fh	reserved	R/W	BEh ^[1]	-
70h	reserved	R/W	0Fh ^[1]	-
71h	reserved	R/W	8Ah ^[1]	-
72h	reserved	R/W	0Fh ^[1]	-
73h	reserved	R/W	32h ^[1]	-
74h	reserved	R/W	0Fh ^[1]	-
75h	reserved	R/W	6Fh ^[1]	-
76h	reserved	R/W	0Eh ^[1]	-
77h	reserved	R/W	F4h ^[1]	-
78h	reserved	R/W	0Ah ^[1]	-
79h to 7Bh	not used	R/W	00h	-
7Ch to 9Ch	reserved	R/W	00h ^[1]	-
9Dh to A0h	not used	R/W	00h	-
A1h and A2h	reserved	R/W	00h ^[1]	-

[1] This register must not be written with values other than default.

Table 10. I²C-bus registers

Index	Name	7 (MSB)	6	5	4	3	2	1	0 (LSB)	
00h	STANDARD	STANDARD[7:0]								
01h	EASY_PROG	0	0	0	0	0	0	0	ACTIVE	
02h	DIV_FUNC	T_IF_SEL[1:0]		0	0	0	POL_DET	VID_MOD	IF_SWAP	
03h	ADC_HEADR	0	0	0	0	ADC_HEADR[3:0]				
04h	PC_PLL_FUNC	PC_PLL_BW[4:0]					PLL_ON	PULL_IN	0	
05h	SSIF_MUTE	0	0	SSIF_AFC_WIN[3:0]				SSIF_MUTE_ TYPE	SSIF_MUTE_ CTRL	
06h ^[1]	reserved	0	1	0	0	1	0	0	0	
07h	reserved	1	0	0	0	0	1	0	0	
08h	reserved	0	0	0	0	1	0	0	0	
09h	DTO_PC_LOW	DTO_PC[7:0]								
0Ah	DTO_PC_MID	DTO_PC[15:8]								
0Bh	DTO_PC_HIGH	DTO_PC[23:16]								
0Ch ^[2]	DTO_SC_LOW	DTO_SC[7:0]								
0Dh ^[3]	DTO_SC_MID	DTO_SC[15:8]								
0Eh ^[3]	DTO_SC_HIGH	DTO_SC[23:16]								
0Fh	FILTERS_1	VID_FILT[2:0]			NOTCH_FILT[4:0]					
10h ^[4]	FILTERS_2	0	0	VID_FILT_ LOW_RIP	1	SBP[3:0]				
11h	GRP_DELAY	GD_EQ_CTRL	0	0	GRP_DEL[4:0]					
12h	D_IF_AGC_SET_1	1	D_IF_AGC_ MODE	1	0	0	0	0	0	
13h	D_IF_AGC_SET_2	1	D_IF_AGC_BW[6:0]							
14h	reserved	0	1	1	0	1	1	1	1	
15h	T_IF_AGC_SET	POL_TIF	T_IF_AGC_SPEED[6:0]							
16h	T_IF_AGC_LIM	UP_LIM[3:0]			LOW_LIM[3:0]					
17h	T_IF_AGC_FORCE	T_FORCE	T_FORCE_VAL[6:0]							
18h	reserved	0	0	0	0	0	1	0	0	
19h	reserved	1	0	0	0	1	0	0	0	
1Ah	reserved	1	0	0	0	0	0	0	0	
1Bh	reserved	0	0	0	0	0	0	0	0	

Table 10. I²C-bus registers ...continued

Index	Name	7 (MSB)	6	5	4	3	2	1	0 (LSB)
1Ch	V_SYNC_DEL	VS_WIDTH[1:0]		VS_POL	VS_DEL[4:0]				
1Dh	CVBS_SET	0	0	1 ^[5]	1	CVBS_EQ_CTRL	FOR_BLK	AUTO_BLK	1
1Eh	CVBS_LEVEL	CVBS_LVL[7:0]							
1Fh	CVBS_EQ	CVBS_EQ[7:0]							
20h	SOUNDSET_1	0	AM_FM_SND[1:0]		DEEMPH[4:0]				
21h	SOUNDSET_2	0	SSIF_AGC_TC	SSIF_AGC_CTRL	HD_DK	FOR_MUTE	AUTO_MUTE	SSIF_SND[1:0]	
22h	SOUND_LEVEL	0	0	0	SND_LVL[4:0]				
23h	SSIF_LEVEL	SSIF_LVL[7:0]							
24h	ADC_SAT	ADC_SAT[7:0]							
25h	AFC	AFC[7:0]							
26h	HVPLL_STAT	-	-	NOISE_DET	MAC_DET	FIDT	V_LOCK	F_H_LOCK	N_H_LOCK
27h	D_IF_AGC_STAT	D_IF_AGC_STAT[7:0]							
28h	T_IF_AGC_STAT	T_IF_AGC_STAT[7:0]							
29h	reserved	-	-	-	-	-	-	-	-
2Ah	reserved	0	0	0	0	0	0	0	0
2Bh	ALT_FILT_COEF ^[6]	0	0	0	0	0	0	ALT_FILT_COEF[1:0]	
2Ch	reserved	-	-	-	-	-	-	-	-
2Dh	SSIF_AGC_STAT	SSIF_AGC_STAT[7:0]							
2Eh	not used	0	0	0	0	0	0	0	0
2Fh	IDENTITY	IDENTITY[7:0]							
30h	CLB_STDBY	0	0	0	0	0	0	STDBY	CLB
31h	reserved	0	0	0	0	0	0	0	0
32h	reserved	-	-	-	-	-	-	-	-
33h	ADC_CTL	0	0	1	0	DCIN	1	SLEEP	PD_ADC
34h	ADC_CTL_2	0	0	0	0	0	1	0	AD_SR54M
35h	VIDEODAC_CTL	0	B_DA_V[5:0]						PD_DA_V
36h	AUDIODAC_CTL	0	B_DA_S[5:0]						PD_DA_S
37h	DAC_REF_CLK_CTL	0	1	0	0	0	0	0	PD_DA_REF

Table 10. I²C-bus registers ...continued

Index	Name	7 (MSB)	6	5	4	3	2	1	0 (LSB)
38h	reserved ^[6]	0	0	1	0	0	0	0	0
39h to 3Bh	not used	0	0	0	0	0	0	0	0
3Ch	reserved	0	0	0	0	0	0	0	0
3Dh	not used	0	0	0	0	0	0	0	0
3Eh	reserved ^[6]	0	1	1	0	0	0	0	1
3Fh	PLL_REG07 ^[6]	0	NSEL7	0	0	0	0	0	0
40h	PLL_REG08 ^[6]	MSEL[7:0]							
41h	PLL_REG09 ^[6]	NSEL[6:0]							
42h	PLL_REG10 ^[6]	0	0	0	PSEL[4:0]				
43h	reserved	0	0	0	0	0	0	0	0
44h	GPIOREG_0	GP1_CF[3:0]			GP0_CF[3:0]				
45h	GPIOREG_1	I2CSW_EN	I2CSW_ON	0	0	GP2_CF[3:0]			
46h	GPIOREG_2	0	0	0	0	0	GP2_VAL	GP1_VAL	GP0_VAL
47h to 4Ah	reserved	-	-	-	-	-	-	-	-
4Bh	GD_EQ_SECT1_C1	GD_EQ_SECT1_C1[7:0]							
4Ch	GD_EQ_SECT1_C2	GD_EQ_SECT1_C2[7:0]							
4Dh	GD_EQ_SECT2_C1	GD_EQ_SECT2_C1[7:0]							
4Eh	GD_EQ_SECT2_C2	GD_EQ_SECT2_C2[7:0]							
4Fh	GD_EQ_SECT3_C1	GD_EQ_SECT3_C1[7:0]							
50h	GD_EQ_SECT3_C2	GD_EQ_SECT3_C2[7:0]							
51h	GD_EQ_SECT4_C1	GD_EQ_SECT4_C1[7:0]							
52h	GD_EQ_SECT4_C2	GD_EQ_SECT4_C2[7:0]							
53h to 56h	not used	0	0	0	0	0	0	0	0
57h	CVBS_EQ_COEF0_LOW	CVBS_EQ_COEF0[7:0]							
58h	CVBS_EQ_COEF0_HIGH	0	0	0	0	CVBS_EQ_COEF0[11:8]			
59h	CVBS_EQ_COEF1_LOW	CVBS_EQ_COEF1[7:0]							

Table 10. I²C-bus registers ...continued

Index	Name	7 (MSB)	6	5	4	3	2	1	0 (LSB)
5Ah	CVBS_EQ_COEF1_ HIGH	0	0	0	0	CVBS_EQ_COEF1[11:8]			
5Bh	CVBS_EQ_COEF2_ LOW	CVBS_EQ_COEF2[7:0]							
5Ch	CVBS_EQ_COEF2_ HIGH	0	0	0	0	CVBS_EQ_COEF2[11:8]			
5Dh	CVBS_EQ_COEF3_ LOW	CVBS_EQ_COEF3[7:0]							
5Eh	CVBS_EQ_COEF3_ HIGH	0	0	0	0	CVBS_EQ_COEF3[11:8]			
5Fh	CVBS_EQ_COEF4_ LOW	CVBS_EQ_COEF4[7:0]							
60h	CVBS_EQ_COEF4_ HIGH	0	0	0	0	CVBS_EQ_COEF4[11:8]			
61h	CVBS_EQ_COEF5_ LOW	CVBS_EQ_COEF5[7:0]							
62h	CVBS_EQ_COEF5_ HIGH	0	0	0	0	CVBS_EQ_COEF5[11:8]			
63h to 66h	not used	0	0	0	0	0	0	0	0
67h	reserved	1	1	1	1	1	1	1	0
68h	reserved	0	0	0	0	1	1	1	1
69h	reserved	1	1	1	1	1	0	1	0
6Ah	reserved	0	0	0	0	1	1	1	1
6Bh	reserved	1	1	1	0	1	1	1	1
6Ch	reserved	0	0	0	0	1	1	1	1
6Dh	reserved	1	1	0	1	1	1	0	1
6Eh	reserved	0	0	0	0	1	1	1	1
6Fh	reserved	1	0	1	1	1	1	1	0
70h	reserved	0	0	0	0	1	1	1	1
71h	reserved	1	0	0	0	1	0	1	0
72h	reserved	0	0	0	0	1	1	1	1
73h	reserved	0	0	1	1	0	0	1	0

Table 10. I²C-bus registers ...continued

Index	Name	7 (MSB)	6	5	4	3	2	1	0 (LSB)
74h	reserved	0	0	0	0	1	1	1	1
75h	reserved	0	1	1	0	1	1	1	1
76h	reserved	0	0	0	0	1	1	1	0
77h	reserved	1	1	1	1	0	1	0	0
78h	reserved	0	0	0	0	1	0	1	0
79h to 7Bh	not used	0	0	0	0	0	0	0	0
7Ch to 9Ch	reserved	0	0	0	0	0	0	0	0
9Dh to A0h	not used	0	0	0	0	0	0	0	0
A1h and A2h	reserved	0	0	0	0	0	0	0	0

[1] Register 06h has to be reprogrammed to new value C4h.

[2] Register 0Ch has to be reprogrammed to new value 00h.

[3] For M/N standard (ADC clock at 54 MHz) register 0Dh and 0Eh have to be reprogrammed to new value 55h.

[4] For M/N standard use narrow SSIF band-pass filter (SBP[3:0] = 0100).

[5] For L/L-accent standard the bit has to be programmed to 0.

[6] These registers have to be programmed to the alternative value in [Table 66](#), if an other frequency is required than 54 MHz for ADC sample frequency.

9.3 Register description

If registers (or bit groups contained in registers) are programmed with invalid values, i.e. values different from those described in the tables below, the default behavior is chosen for the related block. Other settings than described in the tables are not allowed.

9.3.1 Standard setting with easy programming

With the implemented 'easy programming', only one bit sets the TV or FM radio standard with recommended register content. If not suitable however, any of these registers can be written with other settings. With the rising edge of the bit ACTIVE, some of the registers 02h to 23h are programmed internally with the standard dependent settings according to [Table 13](#). The content of registers with address 24h and higher is untouched.

Table 11. STANDARD register (address 00h) bit description

Legend: * = default value.

Bit	Symbol	Access	Value	Description
7 to 0	STANDARD[7:0]	R/W		TV or FM radio standard selection (easy programming)
			0000 0001*	M/N standard
			0000 0010	B standard
			0000 0100	G/H standard
			0000 1000	I standard
			0001 0000	D/K standard
			0010 0000	L standard
			0100 0000	L-accent standard
			1000 0000	FM radio

In addition to application specific software settings following general recommendation should be used (deviating from easy programming values):

- Register 06h: new value C4h
- Register 0Ch: new value 00h
- M/N standard:
 - Register 10h: use narrow SSIF band-pass filter (SBP[3:0] = 0100)
 - Register 0Dh and 0Eh: new value 55h

Remark: When using alternative ADC sampling frequencies the DTO settings have to be adapted accordingly.

Table 12. EASY_PROG register (address 01h) bit description

Legend: * = default value.

Bit	Symbol	Access	Value	Description
7 to 1	-	R/W	000 0000*	not used
0	ACTIVE	R/W		With the rising edge of this bit, the registers 02h to 23h are programmed with the standard dependent settings (see Table 13).
			0*	no action
			1	no action
			0 to 1	activate easy programming

Example: To set the device to B standard e.g., please do the following steps.

1. Write 02h to register STANDARD, address 00h (set B standard)
2. Write 00h to register EASY_PROG, address 01h
3. Write 01h to register EASY_PROG, address 01h (due to 0 to 1 transition of ACTIVE the device is set to B standard, i.e. registers 02h to 23h are programmed automatically according to [Table 13](#))
4. Write 00h to register EASY_PROG, address 01h (reset ACTIVE to logic 0)

Table 13. Easy programming values

Register		Standard							
Index	Name	M/N ^[1]	B	G/H	I	D/K	L	L-accent	FM radio
02h	DIV_FUNC	04h	04h	04h	04h	04h	06h	07h	00h
04h	PC_PLL_FUNC	24h	24h	24h	24h	24h	24h	24h	20h
05h	SSIF_MUTE	04h	04h	04h	04h	04h	04h	04h	04h
06h	reserved	48h	48h	48h	48h	48h	48h	48h	48h
07h	reserved	84h	84h	84h	84h	84h	84h	84h	04h
08h	reserved	08h	08h	08h	08h	08h	08h	08h	08h
09h	DTO_PC_LOW	9Ah	15h	00h	BEh	8Ch	00h	26h	00h
0Ah	DTO_PC_MID	99h	A3h	00h	84h	1Ah	00h	B4h	00h
0Bh	DTO_PC_HIGH	99h	86h	80h	76h	7Eh	80h	17h	80h
0Ch	DTO_SC_LOW	3Dh	7Bh	7Bh	BEh	BEh	D6h	D6h	DAh
0Dh	DTO_SC_MID	20h	09h	09h	84h	84h	B9h	B9h	4Bh
0Eh	DTO_SC_HIGH	59h	6Dh	6Dh	76h	79h	72h	72h	68h
0Fh	FILTERS_1	21h	42h	48h	48h	44h	44h	48h	90h
10h	FILTERS_2	31h	32h	32h	32h	32h	32h	32h	34h
11h	GRP_DELAY	01h	02h	02h	10h	04h	08h	08h	10h
12h	D_IF_AGC_SET_1	A0h	A0h	A0h	A0h	A0h	A0h	A0h	A0h
13h	D_IF_AGC_SET_2	90h	90h	90h	90h	90h	90h	90h	08h
14h	reserved	67h	67h	67h	67h	67h	67h	67h	E7h
1Dh	CVBS_SET	31h	31h	31h	31h	31h	31h	31h	04h
1Eh	CVBS_LEVEL	73h	73h	73h	81h	75h	6Ch	6Ch	73h
1Fh	CVBS_EQ	10h	10h	10h	10h	10h	10h	10h	10h
20h	SOUNDSET_1	21h	22h	22h	22h	22h	44h	44h	22h
21h	SOUNDSET_2	22h	22h	22h	22h	22h	22h	22h	22h
22h	SOUND_LEVEL	08h	04h	04h	04h	04h	04h	04h	02h
23h	SSIF_LEVEL	AFh	AFh	AFh	AFh	AFh	AFh	AFh	AFh

[1] M/N standard settings are equal to the power-on reset (default) values.

9.3.2 Diverse functions (includes tuner IF AGC Pin mode)

Table 14. DIV_FUNC register (address 02h) bit description

Legend: * = default value.

Bit	Symbol	Access	Value	Description
7 and 6	T_IF_SEL[1:0]	R/W		It determines the tuner IF AGC output Pin mode. The open-drain output can be used in special applications in need of a higher control voltage.
			00*	Normal mode
			01	Open-drain mode
			10	3-state mode
			11	not allowed
5 and 4	-	R/W	00*	not used
3	-	R/W	0*	reserved, must be set to logic 0
2	POL_DET	R/W		The polarity detector ensures the proper polarity of the video signal. So, the sync impulses of the video output are near ground level.
			0	polarity detector off
			1*	polarity detector on
1	VID_MOD	R/W		Selects video modulation. The only standards with positive video modulation are L and L-accent.
			0*	negative video modulation
			1	positive video modulation
0	IF_SWAP	R/W		When HIGH, the demodulator expects a swapped IF spectrum. This is the case in L-accent standard. This option is also built in for flexibility reasons.
			0*	normal IF spectrum expected
			1	swapped IF spectrum expected

9.3.3 ADC headroom

Table 15. ADC_HEADR register (address 03h) bit description

Legend: * = default value.

Bit	Symbol	Access	Value	Description
7 to 4	-	R/W	0000*	not used
3 to 0	ADC_HEADR[3:0]	R/W		ADC_HEADR adjusts the needed headroom for the wanted channel's own sound carriers and the N – 1 adjacent sound carriers (PC in L-accent standard). The ADC headroom is related to the sum of all signals. This function is built in for debugging purposes.
			0001*	ADC headroom 3 dB
			0010	ADC headroom 6 dB
			0100	ADC headroom 9 dB
			1000	ADC headroom 12 dB

9.3.4 Picture carrier PLL functions

Table 16. PC_PLL_FUNC register (address 04h) bit description

Legend: * = default value.

Bit	Symbol	Access	Value	Description
7 to 3	PC_PLL_BW[4:0]	R/W		picture carrier PLL loop bandwidth selection
			0 0001	loop bandwidth 15 kHz (not recommended)
			0 0010	loop bandwidth 30 kHz
			0 0100*	loop bandwidth 60 kHz
			0 1000	loop bandwidth 130 kHz
			1 0000	loop bandwidth 280 kHz (not recommended)
2	PLL_ON	R/W		the picture carrier PLL can be disengaged (e.g. in FM radio standard)
			0	PLL off (FM radio) ^[1]
			1*	PLL on ^[2]
1	PULL_IN	R/W		PULL_IN selects the pull-in range of the picture carrier PLL/FPLL
			0*	pull-in range ±1.66 MHz
			1	pull-in range ±830 kHz
0	-	R/W	0*	reserved, must be set to logic 0

[1] The DTO_PC frequency is set via register 09h to 0Bh

[2] The DTO_PC frequency is controlled by VIF_PLL function

9.3.5 Picture and sound carrier DTO

Table 17. DTO_PC_LOW, DTO_PC_MID and DTO_PC_HIGH register (address 09h to 0Bh) bit description

Legend: * = default value.

Address	Register	Bit	Symbol	Access	Value	Description
09h	DTO_PC_LOW	7 to 0	DTO_PC[7:0]	R/W	9Ah*	For picture processing the digital tuned oscillator (DTO_PC) provides its oscillation signal to the demodulator part. For demodulation the oscillation frequency of the DTO_PC is controlled by the VIF_PLL. Optional the DTO_PC can operate at fixed programmed frequency. This will be the case if PLL_ON register is set to “off” mode. In case of VIF_PLL mode of the DTO_PC the register value defines the nominal frequency of AFC register (see Table 39). If PLL_ON register is set to “off” mode the DTO_PC register defines the fixed oscillation frequency value of the DTO_PC. The frequency of the DTO_PC is in relation to the register value by following formula:
0Ah	DTO_PC_MID	7 to 0	DTO_PC[15:8]	R/W	99h*	
0Bh	DTO_PC_HIGH	7 to 0	DTO_PC[23:16]	R/W	99h*	

$$DTO_PC = \frac{f_{ADC}/4 - f_{PC}}{f_{ADC}/4} \times 2^{24}$$

In case of standard L' please use the following

formula: $DTO_PC = f_{PC} \times \frac{4}{f_{ADC}} \times 2^{24}$

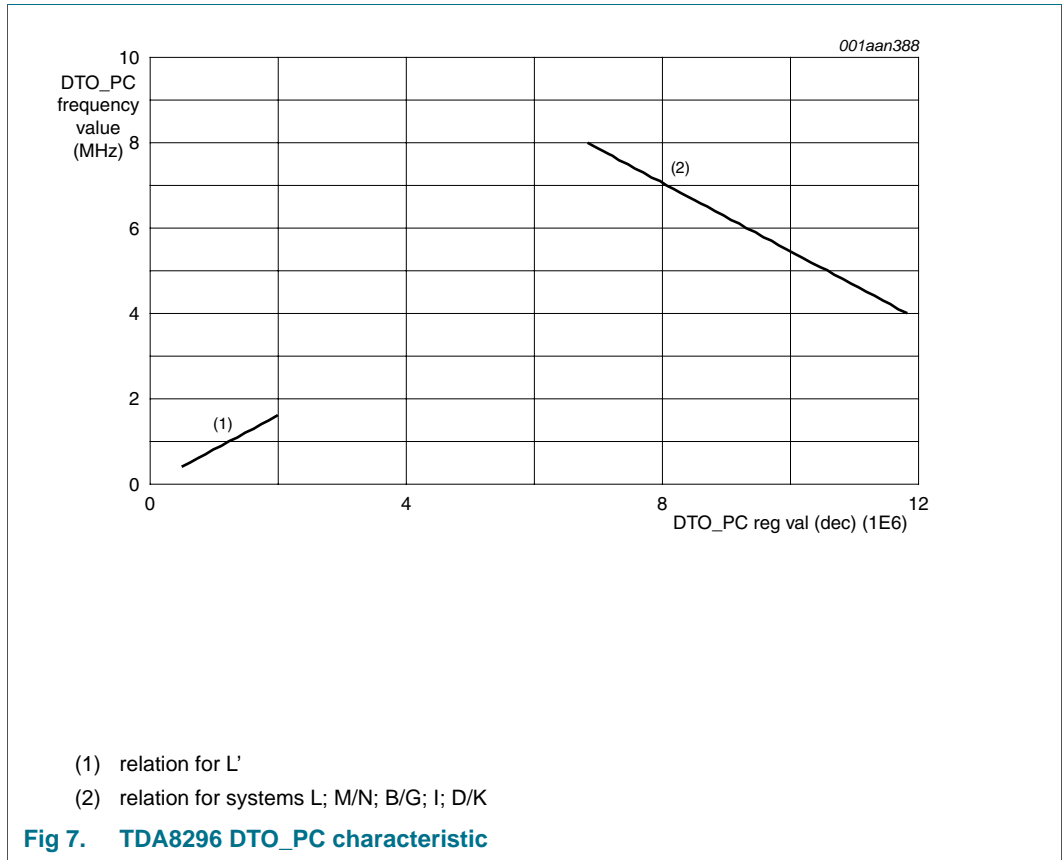

Table 18. Values of DTO_PC per TV standard at 54 MHz sampling frequency

Standard	DTO_SC[23:16]	DTO_SC[15:8]	DTO_SC[7:0]	DTO_PC frequency value
M/N	99h	99h	9Ah	5.40 MHz
B	86h	A3h	15h	6.40 MHz
G	80h	00h	00h	6.75 MHz
I	76h	84h	BEh	7.25 MHz
D/K	7Eh	1Ah	8Ch	6.85 MHz
L	80h	00h	00h	6.75 MHz
L-accent	17h	B4h	26h	1.25 MHz

Table 19. DTO_SC_LOW, DTO_SC_MID and DTO_SC_HIGH register (address 0Ch to 0Eh) bit description

Legend: * = default value.^[1]

Address	Register	Bit	Symbol	Access	Value	Description
0Ch	DTO_SC_LOW	7 to 0	DTO_SC[7:0]	R/W	00h*	The DTO_SC is suited for SSIF band-pass filter tuning. DTO_SC is calculated according to the following formula, whereas f_{SC} is the SSIF band-pass center frequency:
0Dh	DTO_SC_MID	7 to 0	DTO_SC[15:8]	R/W	20h*	
0Eh	DTO_SC_HIGH	7 to 0	DTO_SC[23:16]	R/W	59h*	

$$DTO_SC = \frac{f_{SC}}{f_{ADC}/4} \times 2^{24}$$

[1] Deviating from easy programming values for DTO_SC[23:0] the values from [Table 20](#) should be used.

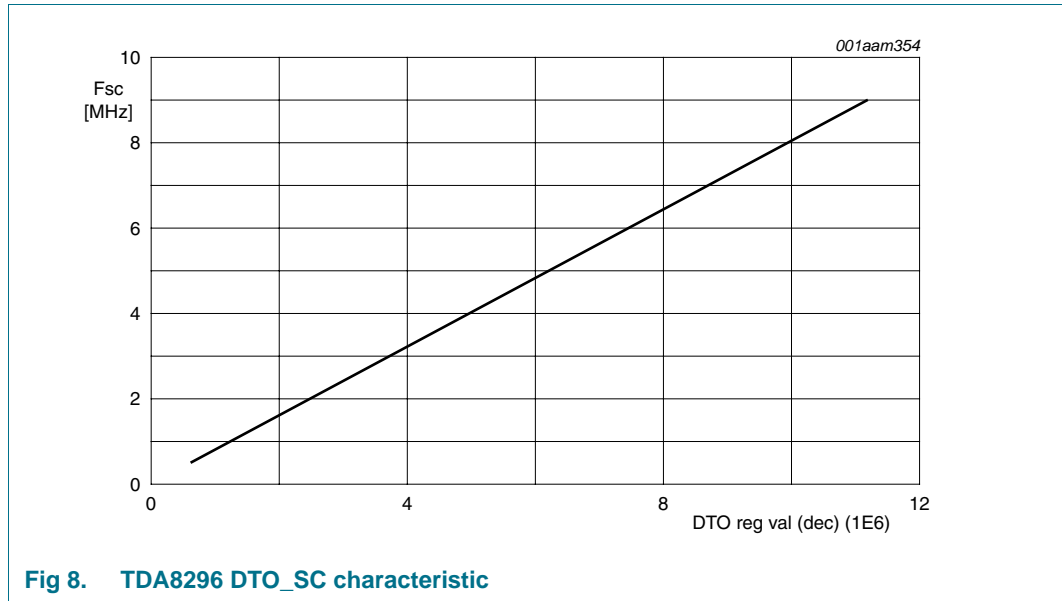

Fig 8. TDA8296 DTO_SC characteristic

Table 20. Values for SSIF mode at 54 MHz sampling frequency

Standard	DTO_SC[23:16]	DTO_SC[15:8]	DTO_SC[7:0]	Band-pass center frequency
M/N	55h	55h	00h	4.5 MHz
B	6Dh	09h	00h	5.75 MHz
G/H	6Dh	09h	00h	5.75 MHz
I	76h	84h	00h	6.25 MHz
D/K	76h	84h	00h	6.25 MHz
L/L-accent	72h	B9h	00h	6.05 MHz
FM radio	68h	4Bh	00h	5.5 MHz

9.3.6 Filter settings

Table 21. FILTERS_1 register (address 0Fh) bit description

Legend: * = default value.

Bit	Symbol	Access	Value	Description
7 to 5	VID_FILT[2:0]	R/W		video low-pass filter to remove all unwanted frequencies (own sound carriers) above video content (see Figure 9)
			001*	video low-pass filter 4 MHz
			010	video low-pass filter 5 MHz
			100	video low-pass filter off
4 to 0	NOTCH_FILT[4:0]	R/W		The notch filter attenuates the adjacent sound carrier N – 1, which is located differently dependent on standard (see Figure 10).
			0 0001*	notch filter at 6.9 MHz for M/N standard
			0 0010	notch filter at 7.9 MHz for B standard
			0 0100	notch filter at 8.3 MHz for D/K and L standard
			0 1000	notch filter at 9.25 MHz for G/H, I and L-accent standard
1 0000	notch filter bypass			

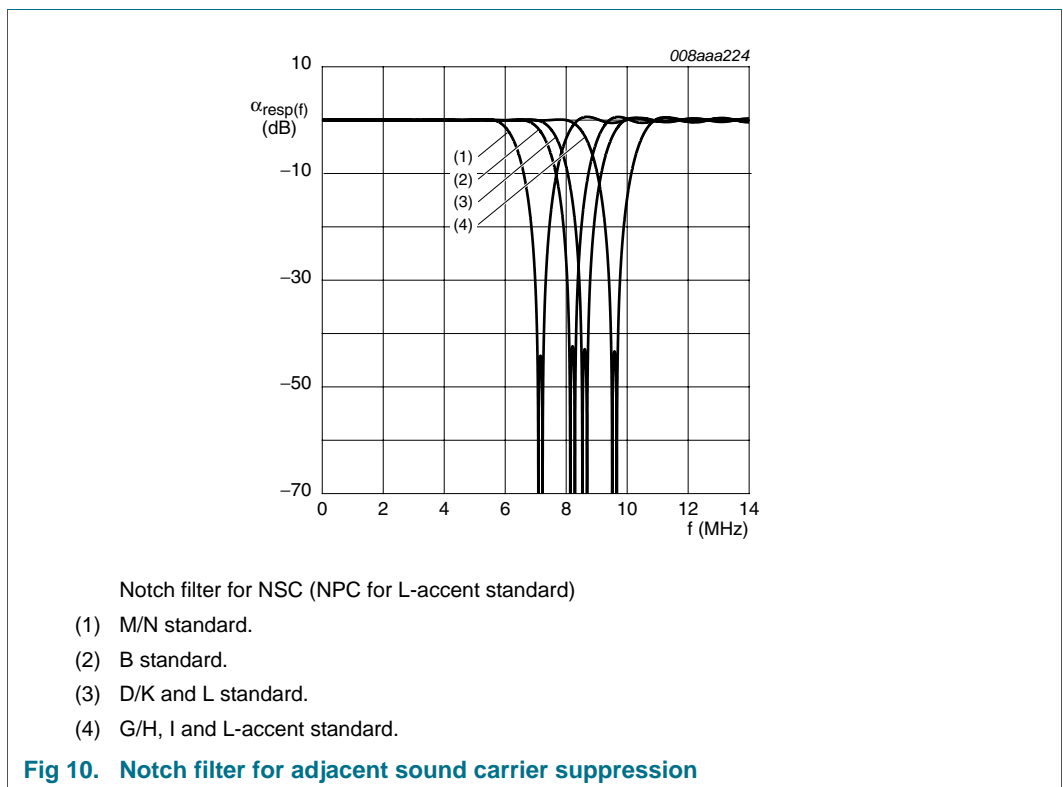
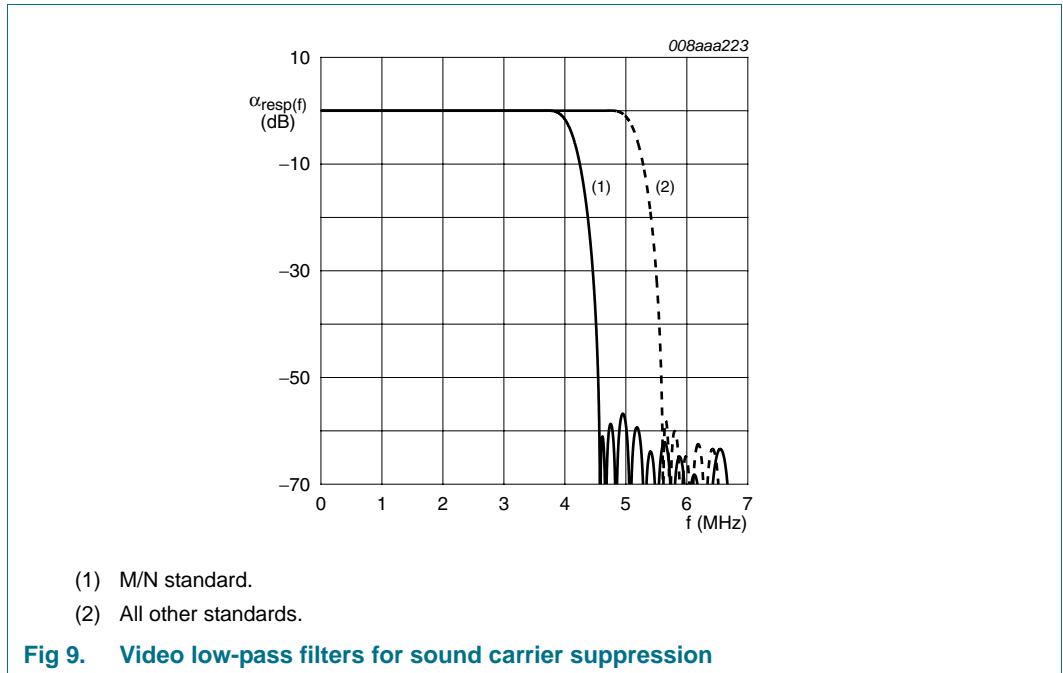

Table 22. FILTERS_2 register (address 10h) bit description

Legend: * = default value.

Bit	Symbol	Access	Value	Description
7 and 6	-	R/W	00*	not used
5	VID_FILT_ LOW_RIP	R/W	0	video filter characteristic adjust smooth roll-off
			1*	low ripple
4	-	R/W	1*	reserved, must be set to logic 1
3 to 0	SBP[3:0]	R/W		The SSIF band-pass attenuates unwanted video frequencies ^{[1][2]} , e.g. color carrier. For FM radio standard it provides almost channel selectivity (see Figure 12).
			0001*	SSIF band-pass, wide bandwidth
			0010	SSIF band-pass, normal bandwidth (1.1 MHz, all TV standards)
			0100	SSIF band-pass, narrow bandwidth (200 kHz, FM radio)

[1] SSIF band-pass center frequency is controlled by DTO_SC[23:0]. See [Table 20](#) for recommended DTO values.

[2] Deviating from easy programming values for FILTERS_2, the narrow SSIF band-pass filter (SPB[3:0] = 0100) should be used for M/N standard.

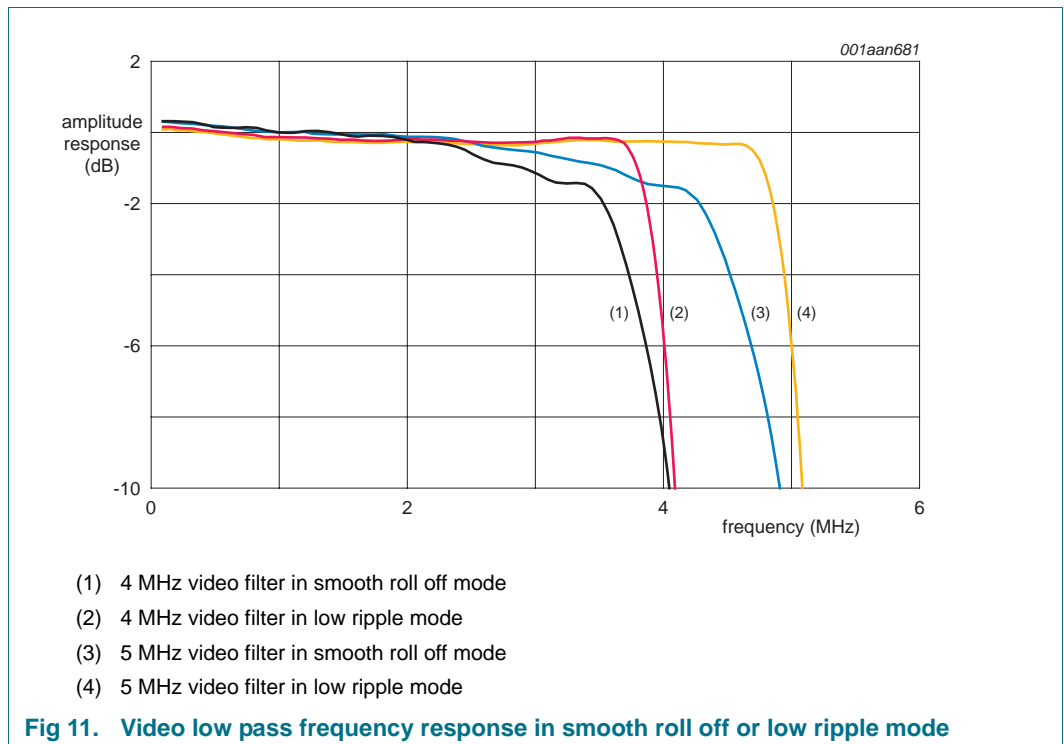

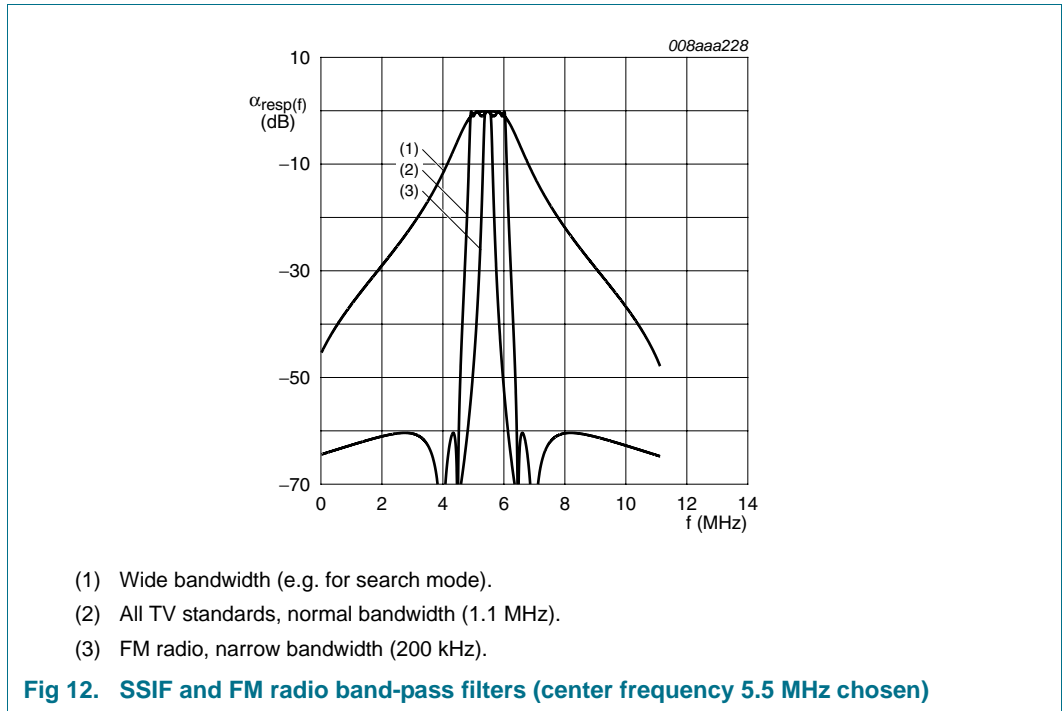

9.3.7 Group delay equalization

Table 23. GRP_DELAY register (address 11h) bit description

Legend: * = default value.

Bit	Symbol	Access	Value	Description
7	GD_EQ_CTRL	R/W		group delay equalizer control; this is the control for the freely programmable group delay equalizer; for details see Section 9.3.19
			0*	off (equalizer bypassed)
			1	on (equalizer active)
6 and 5	-	R/W	00*	reserved, must be set to logic 00
4 to 0	GRP_DEL[4:0]	R/W		group delay equalization to correct the transmitter predistortion
			0 0001*	group delay M/N standard
			0 0010	group delay B/G/H standard
			0 0100	group delay D/K standard
			0 1000	group delay L/L-accent standard
			1 0000	group delay I (flat) standard

9.3.8 Digital IF AGC functions

Table 24. D_IF_AGC_SET_1 register (address 12h) bit description

Legend: * = default value.

Bit	Symbol	Access	Value	Description
7	-	R/W	1*	reserved, must be set to logic 1
6	D_IF_AGC_MODE	R/W		If HIGH, the digital IF AGC detection and gating is done during the back porch of the video signal. This Detection mode can be used for all standards (also L/L-accent standard) without impact on the IF AGC loop speed.
			0*	peak sync AGC (slow peak white L/L-accent standard)
			1	black level AGC detection
5 to 0	-	R/W	10 0000*	reserved, must be set to logic 10 0000

Table 25. D_IF_AGC_SET_2 register (address 13h) bit description

Legend: * = default value.

Bit	Symbol	Access	Value	Description
7	-	R/W	1*	reserved, must be set to logic 1
6 to 0	D_IF_AGC_BW[6:0]	R/W		digital IF AGC 3 dB-loop bandwidth setting
			000 0001	25 Hz
			000 0010	50 Hz
			000 0100	100 Hz
			000 1000	200 Hz
			001 0000*	400 Hz
			010 0000	800 Hz
			100 0000	1.6 kHz (not recommended)

9.3.9 Tuner IF AGC functions

Table 26. T_IF_AGC_SET register (address 15h) bit description

Legend: * = default value.

Bit	Symbol	Access	Value	Description
7	POL_TIF	R/W		tuner IF AGC polarity
			0	inverted tuner IF AGC polarity
			1*	normal tuner IF AGC polarity: the higher the necessary gain, the higher the IF AGC voltage

Table 26. T_IF_AGC_SET register (address 15h) bit description ...continued

Legend: * = default value.

Bit	Symbol	Access	Value	Description
6 to 0	T_IF_AGC_SPEED[6:0]	R/W		T_IF_AGC_SPEED determines the tuner IF AGC loop speed
			000 0001	-18 dB nominal
			000 0010	-12 dB nominal
			000 0100	-6 dB nominal
			000 1000*	nominal speed (determined by the tuner IF control slope)
			001 0000	+6 dB nominal
			010 0000	+12 dB nominal
			100 0000	+18 dB nominal

Table 27. T_IF_AGC_LIM register (address 16h) bit description

Legend: * = default value.

Bit	Symbol	Access	Value	Description
7 to 4	UP_LIM[3:0]	R/W		The tuner IF AGC output voltage can be limited to interface with concepts having power supply < 3.3 V. UP_LIM determines the upper limit from $1\sqrt{2}$ FS (= 0h) to FS (= Fh). The format is straight binary.
			1111*	set upper limit to maximum
3 to 0	LOW_LIM[3:0]	R/W		LOW_LIM determines the lower tuner IF AGC output limit from 0 (= 0h) to $1\sqrt{2}$ FS (= Fh). The format is straight binary.
			0000*	set lower limit to minimum

Table 28. T_IF_AGC_FORCE register (address 17h) bit description

Legend: * = default value.

Bit	Symbol	Access	Value	Description
7	T_FORCE	R/W		the tuner IF AGC output voltage can be forced externally to a fixed voltage, determined by T_FORCE_VAL
			0*	tuner IF AGC normal operation
			1	tuner IF AGC output voltage determined by T_FORCE_VAL
6 to 0	T_FORCE_VAL[6:0]	R/W		T_FORCE_VAL determines the tuner IF AGC forced value. So the tuner IF AGC can be fixed to a certain value for debugging purposes. Format is straight binary.
			3Fh*	$0.5 \times V_{DD(3V3)}$, i.e. 1.65 V nominally
			XXh	don't care if T_FORCE = 0

9.3.10 V-sync adjustment

Table 29. V_SYNC_DEL register (address 1Ch) bit description

Legend: * = default value.

Bit	Symbol	Access	Value	Description
7 and 6	VS_WIDTH[1:0]	R/W		VS_WIDTH determines the width (in horizontal lines) of the V-sync gating pulse (needed for gating of tuner RF AGC2)
			00	width 1 line (64 μ s)
			01*	width 2 lines
			10	width 4 lines
			11	width 16 lines
5	VS_POL	R/W		VS_POL determines the polarity of the V-sync pulse: if VS_POL = 1, the first edge of the pulse is positive, else negative.
			0	first edge negative
			1*	first edge positive
4 to 0	VS_DEL[4:0]	R/W		VS_DEL determines the first edge position of the output V-sync pulse compared to the beginning of the vertical blanking interval: <i>pulse_position = (VS_DEL - 12) lines</i>
			0Fh*	first edge 3 lines after beginning of vertical interval

9.3.11 CVBS settings

Table 30. CVBS_SET register (address 1Dh) bit description

Legend: * = default value.

Bit	Symbol	Access	Value	Description
7 and 6	-	R/W	00*	not used
5 and 4	-	R/W	11*	must be set to logic 11 or in case of L/L-accent to 01
3	CVBS_EQ_CTRL	R/W		video equalizer mode control
			0*	mode using predefined settings like described in Table 32
			1	free programmable mode; for details see Section 9.3.19
2	FOR_BLK	R/W		when active, the video output is always blanked, e.g. for channel change (forced blank)
			0*	no action
			1	video blanked
1	AUTO_BLK	R/W		when active, the video output is blanked if the horizontal line lock flag (N_H_LOCK, see Table 41) is not present
			0*	auto-blanking off
			1	auto-blanking on
0	-	R/W	1*	reserved, must be set to logic 1

Table 31. CVBS_LEVEL register (address 1Eh) bit description

Legend: * = default value.

Bit	Symbol	Access	Value	Description
7 to 0	CVBS_LVL[7:0]	R/W		With this byte, the nominal video output level is freely programmable. The format is unsigned integer (offset binary). Settings below 40h and above C0h, which correspond to -5 dB (40h) and +4.5 dB (C0h) related to the default value, are forbidden. In the following some possible settings in 1 dB steps are shown.
			51h	-3 dB nominal
			5Bh	-2 dB nominal
			66h	-1 dB nominal
			73h*	nominal: 1 V (p-p) video output level (sync-peak)
			81h	+1 dB nominal
			91h	+2 dB nominal
			A2h	+3 dB nominal

Table 32. CVBS_EQ register (address 1Fh) bit description

Legend: * = default value.

Bit	Symbol	Access	Value	Description
7 to 0	CVBS_EQ[7:0]	R/W		The video equalizer can be used for the compensation of a principal tuner tilt or to change the video frequency according to customer taste. The figures given are at 5 MHz CVBS with respect to low frequencies (see Figure 13).
			0000 0001	The video frequency response is -8 dB for 5 MHz.
			0000 0010	The video frequency response is -6 dB for 5 MHz.
			0000 0100	The video frequency response is -4 dB for 5 MHz.
			0000 1000	The video frequency response is -2 dB for 5 MHz.
			0001 0000*	The video frequency response is made flat in this mode.
			0010 0000	The video frequency response is +2 dB (peaking) for 5 MHz.
			0100 0000	The video frequency response is +4 dB (peaking) for 5 MHz.
			1000 0000	The video frequency response is +6 dB (peaking) for 5 MHz.

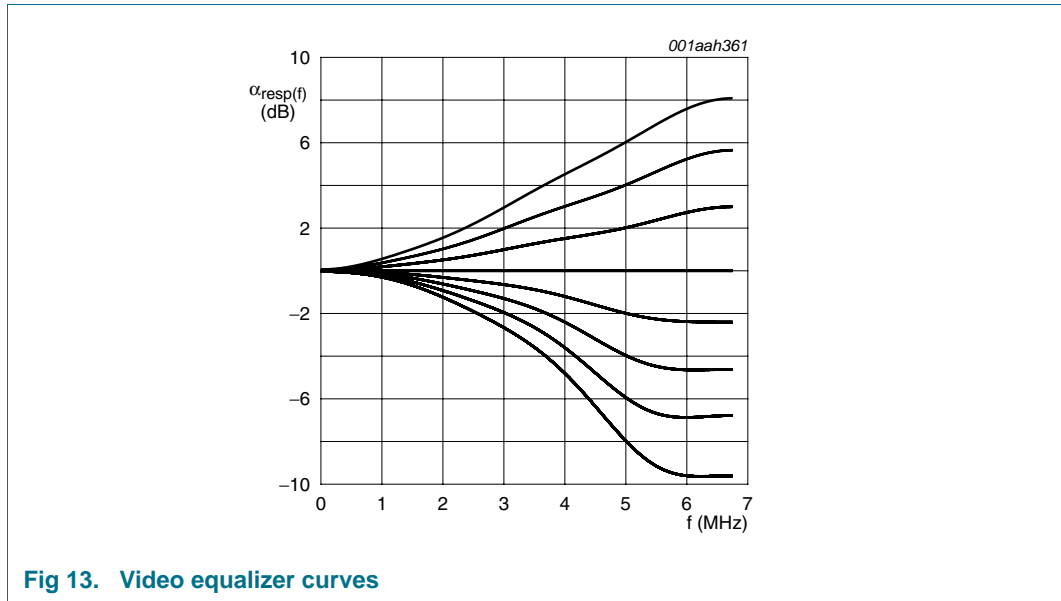

Fig 13. Video equalizer curves

9.3.12 SSIF and mono sound settings

Table 33. SSIF_MUTE register (address 05h) bit description

Legend: * = default value.

Bit	Symbol	Access	Value	Description
7 and 6	-	R/W	00*	not used
5 to 2	SSIF_AFC_WIN[3:0]	R/W		SSIF AFC mute window configuration
			0001*	±100 kHz
			0010	±200 kHz
			0100	±400 kHz
			1000	±800 kHz
1	SSIF_MUTE_TYPE	R/W		SSIF auto-mute behavior
			0*	reduced gain
			1	mute
0	SSIF_MUTE_CTRL	R/W		auto-mute of SSIF output
			0*	off
			1	on

Table 34. SOUNDSET_1 register (address 20h) bit description

Legend: * = default value.

Bit	Symbol	Access	Value	Description
7	-	R/W	0*	reserved, must be set to logic 0
6 and 5	AM_FM_SND[1:0]	R/W		Output mode for inbuilt FM/AM mono sound demodulator
			01*	FM sound
			10	AM sound (only L/L-accent standard)
			XX	don't care if SSIF output is chosen (SSIF_SND[1:0] = 10)

Table 34. SOUNDSET_1 register (address 20h) bit description ...continued

Legend: * = default value.

Bit	Symbol	Access	Value	Description
4 to 0	DEEMPH[4:0]	R/W		mono sound de-emphasis adjustment to compensate transmitter pre-emphasis; or low-pass filter to remove out of audio band interferers
			0 0001*	de-emphasis of 75 μ s for M/N standard or non-European FM radio to compensate the transmitter pre-emphasis
			0 0010	de-emphasis of 50 μ s for B/G/H, D/K and I standard or European FM radio to compensate the transmitter pre-emphasis
			0 0100	low-pass filter with 30 kHz -3 dB cut-off frequency to remove out of audio band interferers
			0 1000	low-pass filter with 140 kHz -3 dB cut-off frequency to drive an external BTSC stereo decoder
			1 0000	The de-emphasis filter is bypassed. This can be used for debugging or other purposes.

Table 35. SOUNDSET_2 register (address 21h) bit description

Legend: * = default value.

Bit	Symbol	Access	Value	Description
7	-	R/W	0*	reserved, must be set to logic 0
6	SSIF_AGC_TC	R/W		SSIF AGC time constant for L/L-accent standard
			0*	slow (normal)
			1	fast
5	SSIF_AGC_CTRL	R/W		SSIF AGC control
			0	SSIF AGC off
			1*	SSIF AGC on
4	HD_DK	R/W		When active, the internal FM mono sound demodulator can handle excessive FM deviations up to 400 kHz. This might happen in D/K standard China. To activate this mode, it is mandatory to set D/K standard first. The sound output level has to be adapted accordingly by the microprocessor to avoid sound DAC clipping. E.g. for 400 kHz FM deviation, the -12 dB setting of the sound level register (see Table 36) is recommended.
			0*	high Deviation mode off
			1	high Deviation mode on
			X	don't care if SSIF output is chosen (SSIF_SND[1:0] = 10)
3	FOR_MUTE	R/W		When active, the mono sound signal is always muted. This setting only makes sense in case the sound DAC output is also set to mono sound (SSIF_SND[1:0] = 01). FOR_MUTE has no function if SSIF_SND[1:0] = 10.
			0*	off
			1	on
			X	don't care if SSIF output is chosen (SSIF_SND[1:0] = 10)

Table 35. SOUNDSET_2 register (address 21h) bit description ...continued

Legend: * = default value.

Bit	Symbol	Access	Value	Description
2	AUTO_MUTE	R/W		When active, the mono sound signal is muted if the horizontal lock flag (N_H_LOCK) disappears. This setting only makes sense in case the sound DAC output is also set to mono sound (SSIF_SND[1:0] = 01). FOR_MUTE has no function if SSIF_SND[1:0] = 10.
			0*	off
			1	on
			X	don't care if SSIF output is chosen (SSIF_SND[1:0] = 10)
1 and 0	SSIF_SND[1:0]	R/W		either mono sound or SSIF can be chosen for the sound DAC output
			01	mono sound ^[1]
			10*	SSIF

[1] Before activating mono sound, the TV standard needs to be set via easy programming

Table 36. SOUND_LEVEL register (address 22h) bit description

Legend: * = default value.

Bit	Symbol	Access	Value	Description
7 to 5	-	R/W	000*	not used
4 to 0	SND_LVL[4:0]	R/W		mono sound output level
			0 0001	-12 dB nominal; implemented for flexibility reasons. With this setting, the adaptation to different standard requirements can be done.
			0 0010	-6 dB nominal; implemented for flexibility reasons. With this setting, the adaptation to different standard requirements can be done. It is chosen for FM radio because of the large FM deviation involved.
			0 0100	Nominal setting; FM deviations up to 100 kHz can be processed without sound DAC clipping. The clipping level is 535 mV (RMS) typically.
			0 1000*	+6 dB nominal; chosen for M/N standard due to less nominal frequency deviation
			1 0000	+12 dB nominal; implemented for flexibility reasons. With this setting, the adaptation to different standard requirements can be done.
X	XXXX	don't care if SSIF output is chosen (SSIF_SND[1:0] = 10)		

Table 37. SSIF_LEVEL register (address 23h) bit description

Legend: * = default value.

Bit	Symbol	Access	Value	Description
7 to 0	SSIF_LVL[7:0]	R/W		SSIF output level adjustment; SSIF AGC on (21h[5] = 1)
			1111 1111	+3 dB
			:	:
			1010 1111*	0 dB
			:	:
			0100 0000 to 0000 0000	–8.7 dB
				SSIF output level adjustment; SSIF AGC off (21h[5] = 0)
			XXX0 0001	–12 dB nominal; implemented for flexibility reasons. With this setting, the adaptation to different standard requirements can be done.
			XXX0 0010	–6 dB nominal; implemented for flexibility reasons. With this setting, the adaptation to different standard requirements can be done.
			XXX0 0100	Nominal setting; typical output level is 55 mV (RMS) for PC / SC ratio of 13 dB (see Section 12 , SSIF/mono sound output).
			XXX0 1000	+6 dB nominal; implemented for flexibility reasons. With this setting, the adaptation to different standard requirements can be done.
			XXX1 0000	+12 dB nominal; implemented for flexibility reasons. With this setting, the adaptation to different standard requirements can be done.
			XXXX XXXX	don't care if mono sound output is chosen (SSIF_SND[1:0] = 01)

Remark: The SSIF level depends also on the used capacitor C_S . Please refer to [Figure 14](#)

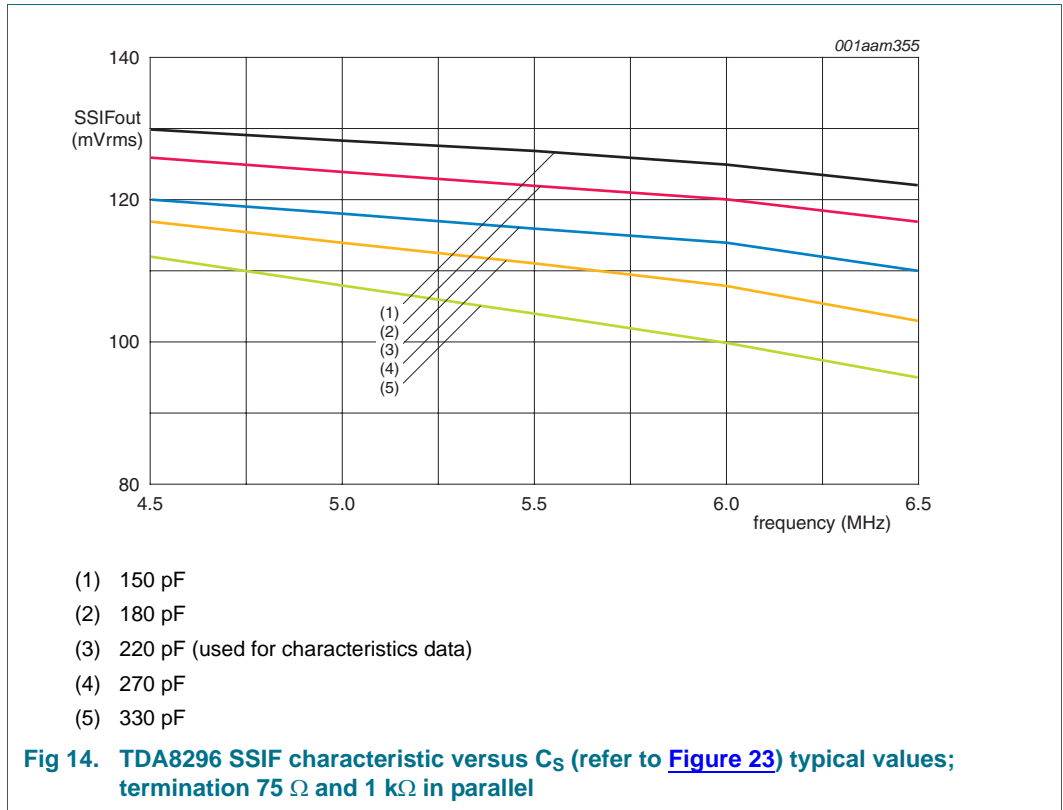

9.3.13 Status registers: ADC saturation, AFC, H/V PLL and AGC

Table 38. ADC_SAT register (address 24h) bit description

Bit	Symbol	Access	Value	Description
7 to 0	ADC_SAT[7:0]	R	-	With ADC_SAT, the ADC saturation percentage in a period of 40 ms can be calculated by the following formula: $saturation = \frac{ADC_SAT}{256} (\%)$.

Table 39. AFC register (address 25h) bit description

Bit	Symbol	Access	Value	Description
7 to 0	AFC[7:0]	R	-	<p>This is the readout for AFC. AFC contains the frequency deviation from nominal IF picture carrier. The format is twos complement, 13.2 kHz steps are done per LSB. See Table 40 for details. The frequency deviation could also be given by the following formula:</p> $f_{IF} - f_{nom} = \frac{-AFC \times 6750}{512} \text{ (kHz)}$ <p>For a frequency deviation from the nominal IF picture carrier greater than the FPLL pull-in capability (–830.6 kHz to +843.8 kHz or –1674.3 kHz to +1687.5 kHz), the output reading is undefined. The AFC lock indication can be taken from the N_H_LOCK information from the H-sync PLL. The lock occurs inside a frequency window, which is determined by the pull-in capability of the FPLL.</p>

Table 40. Calculation of frequency deviation from AFC value

Deviation from nominal IF frequency ^[1]	AFC[7]	AFC[6]	AFC[5]	AFC[4]	AFC[3]	AFC[2]	AFC[1]	AFC[0]
$f_{IF} = f_{nom} - 1674.3 \text{ kHz}$	0	1	1	1	1	1	1	1
$f_{IF} = f_{nom} - 1661.1 \text{ kHz}$	0	1	1	1	1	1	1	0
:	:	:	:	:	:	:	:	:
$f_{IF} = f_{nom} - 830.6 \text{ kHz}$	0	0	1	1	1	1	1	1
$f_{IF} = f_{nom} - 817.4 \text{ kHz}$	0	0	1	1	1	1	1	0
:	:	:	:	:	:	:	:	:
$f_{IF} = f_{nom} - 13.2 \text{ kHz}$	0	0	0	0	0	0	0	1
$f_{IF} = f_{nom}$	0	0	0	0	0	0	0	0
$f_{IF} = f_{nom} + 13.2 \text{ kHz}$	1	1	1	1	1	1	1	1
:	:	:	:	:	:	:	:	:
$f_{IF} = f_{nom} + 830.6 \text{ kHz}$	1	1	0	0	0	0	0	1
$f_{IF} = f_{nom} + 843.8 \text{ kHz}$	1	1	0	0	0	0	0	0
:	:	:	:	:	:	:	:	:
$f_{IF} = f_{nom} + 1674.3 \text{ kHz}$	1	0	0	0	0	0	0	1
$f_{IF} = f_{nom} + 1687.5 \text{ kHz}$	1	0	0	0	0	0	0	0

[1] See [Section 12](#) for nominal IF frequencies.

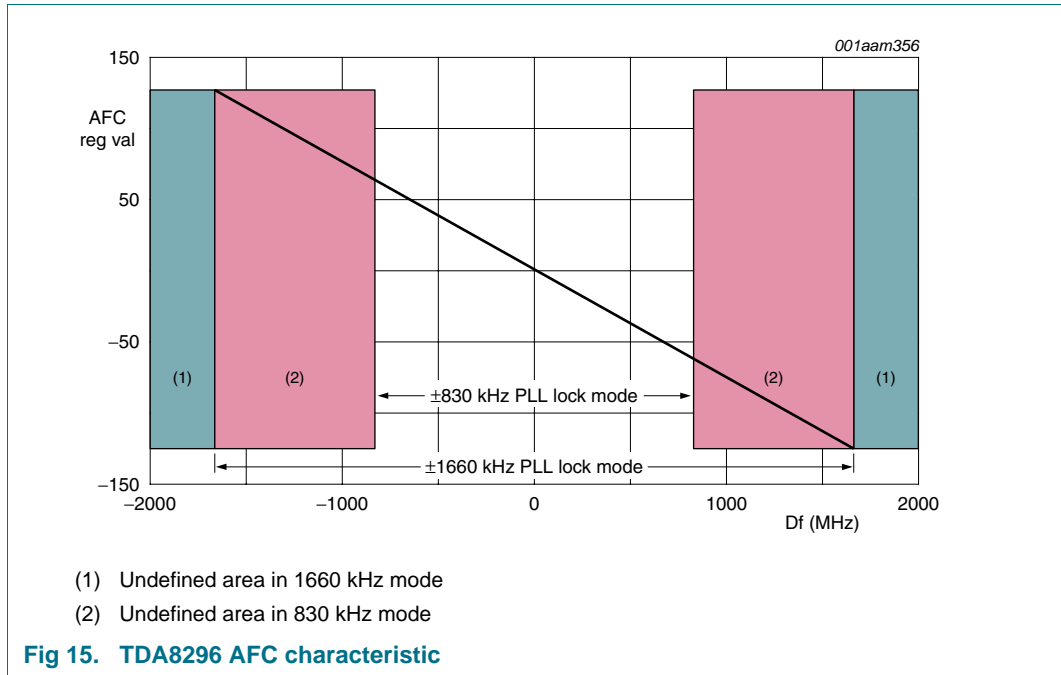

Table 41. HVPLL_STAT register (address 26h) bit description

Bit	Symbol	Access	Value	Description
7 and 6	-	R	-	not used
5	NOISE_DET	R	-	This flag gets HIGH in case the video S/N (weighted) drops below 30 dB. For proper and noise free video signals it stays LOW. It can be used for debugging and other purposes.
4	MAC_DET	R	-	This flag indicates the presence of copy-guarded video content from STBs or VCRs. It can be used for debugging and other purposes.
3	FIDT	R	-	This flag indicates the frame rate (50 Hz or 60 Hz). When active, 60 Hz is detected. It can be used for debugging and other purposes.
2	V_LOCK	R	-	This flag is active, if a proper frame (50 Hz or 60 Hz) is detected. It can be used for debugging and other purposes.
1	F_H_LOCK	R	-	This flag is active, if a proper H-sync (15.625 kHz or 15.734 kHz) is detected (Fast mode). It can be used for debugging and other purposes.
0	N_H_LOCK	R	-	This flag is active, if a proper H-sync (15.625 kHz or 15.734 kHz) is detected (Normal mode). It can be used for debugging and other purposes.

Table 42. D_IF_AGC_STAT register (address 27h) bit description

Bit	Symbol	Access	Value	Description
7 to 0	D_IF_AGC_STAT[7:0]	R	-	D_IF_AGC_STAT is the digital IF AGC status readout byte. Contains the digital IF AGC loop DC information. The format is twos complement. To get the internal gain in dB, the following formula can be used: $gain = \frac{D_IF_AGC_STAT + 50}{3.675} (dB).$

Table 43. T_IF_AGC_STAT register (address 28h) bit description

Bit	Symbol	Access	Value	Description
7 to 0	T_IF_AGC_STAT[7:0]	R	-	T_IF_AGC_STAT is the IF AGC status readout byte. Contains the tuner IF AGC loop DC information. The format is offset binary.

Table 44. ALT_FILT_COEF register (address 2Bh) bit description

Bit	Symbol	Access	Value	Description	Frequency
7 to 2	not used	R/W	0	not used.	
1 to 0	ALT_FILT_COEF	R/W	00	internal selection of fixed coefficients for video low pass filter using an ADC sampling frequency of	54.00 MHz
			01		50.75 MHz
			10		57.25 MHz

Table 45. SSIF_AGC_STAT register (address 2Dh) bit description

Bit	Symbol	Access	Value	Description
7 to 0	SSIF_AGC_STAT[7:0]	R	-	SSIF_AGC_STAT contains the SSIF AGC gain information. To get the internal gain in dB, the following formula can be used: $gain = 20 \log_{10} \frac{SSIF_AGC_STAT}{8}$. The value is approximately the PC / SC ratio.

9.3.14 Chip identification and Standby mode

Table 46. IDENTITY register (address 2Fh) bit description

Bit	Symbol	Access	Value	Description
7 to 0	IDENTITY[7:0]	R	1000 1100*	chip identification, value corresponds to TDA8296

Table 47. CLB_STDBY register (address 30h) bit description

Legend: * = default value.

Bit	Symbol	Access	Value	Description
7 to 3	-	R/W	0000 0*	not used
2	-	R/W	0*	reserved, must be set to logic 0

Table 47. CLB_STDBY register (address 30h) bit description ...continued

Legend: * = default value.

Bit	Symbol	Access	Value	Description
1	STDBY	R/W		When STDBY is set to logic 1, the chip enters in Standby mode, and its power consumption is reduced. The IF AGC pin is set to high-ohmic. The default value is logic 0, which means that the chip is active.
			0*	Normal mode
			1	Standby mode
0	CLB	R/W		This signal clears the TDA8296 through the I ² C-bus interface (software reset). To activate the reset, just write CLB = 0. This software reset will not affect the content of the registers.
			0	activate soft reset
			1*	normal operation

9.3.15 ADC control

In the TDA8296 a 12-bit ADC is implemented sampling with a 54 MHz clock (27 MHz optional).

Table 48. ADC_CTL register (address 33h) bit description

Legend: * = default value.

Bit	Symbol	Access	Value	Description
7 to 4	-	R/W	0010*	reserved, must be set to logic 0010
3	DCIN	R/W		The input signal of the ADC can be either AC coupled by means of two capacitors or connected directly to the inputs (DC coupled).
			0*	AC coupling
			1	DC coupling
2	-	R/W	1*	reserved, must be set to logic 1
1	SLEEP	R/W		When HIGH, SLEEP sets the ADC into its Sleep mode. Both bias current and clock are switched off. In this mode, the current consumption is reduced by a factor of 6. The reference circuit will remain active in order to guarantee a fast recovery from Sleep mode.
			0*	Normal mode
			1	ADC Sleep mode
0	PD_ADC	R/W		When HIGH, PD_ADC sets the ADC into its Power-down mode. All internal currents are switched off. In this mode, the current consumption is near zero (leakage current only).
			0*	Normal mode
			1	ADC Power-down mode

Table 49. ADC_CTL_2 register (address 34h) bit description

Legend: * = default value.

Bit	Symbol	Access	Value	Description
7 to 3	-	R/W	0000 0*	not used
2 and 1	-	R/W	10*	reserved, must be set to logic 10

Table 49. ADC_CTL_2 register (address 34h) bit description ...continued

Legend: * = default value.

Bit	Symbol	Access	Value	Description
0	AD_SR54M	R/W		AD_SR54M sets the ADC sampling rate
			0	ADC sampling rate 27 MHz; first decimation filter is bypassed
			1*	ADC sampling rate 54 MHz

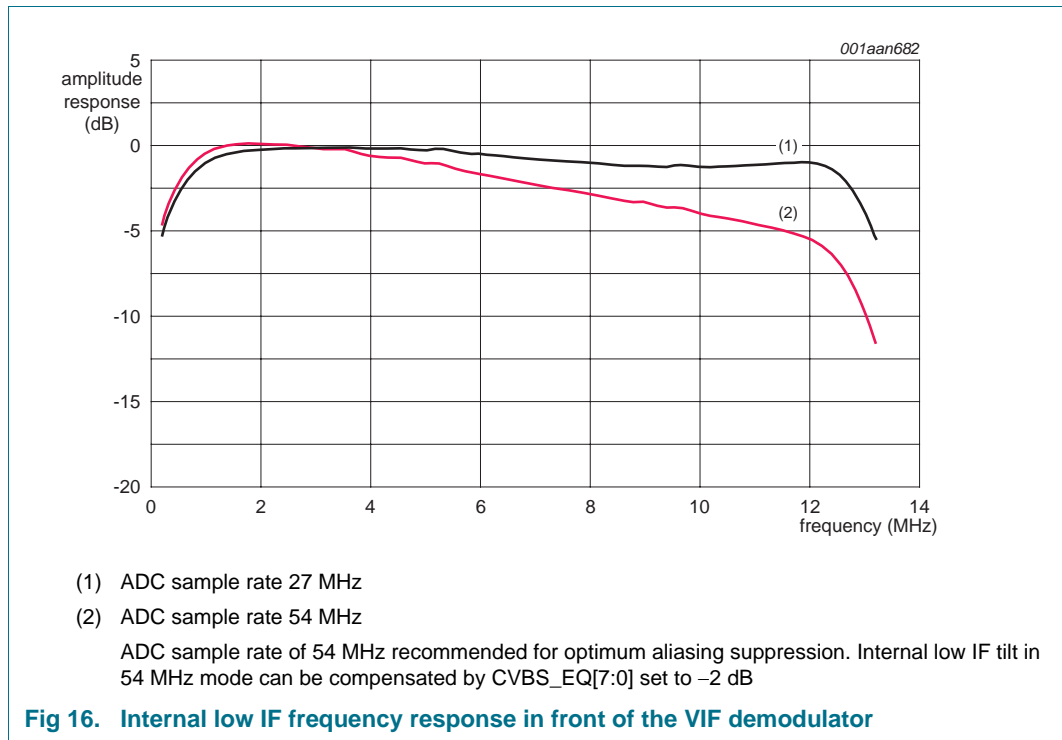

9.3.16 Video and sound DAC control

The TDA8296 implements two 10-bit DAC modules (CVBS and sound outputs) which are sampled by a 108 MHz clock. A reference module derives biasing currents for the two DACs.

Table 50. VIDEODAC_CTL register (address 35h) bit description

Legend: * = default value.

Bit	Symbol	Access	Value	Description
7	-	R/W	0*	reserved, must be set to logic 0
6 to 1	B_DA_V[5:0]	R/W		B_DA_V modifies between 50% to 100% the full scale DAC output current. See Section 13.3 .
			00 0000	minimum current setting
			11 1111*	maximum current setting
0	PD_DA_V	R/W		When HIGH, PD_DA_V sets the video DAC into its Power-down mode.
			0*	Normal mode
			1	video DAC Power-down mode

Table 51. AUDIODAC_CTL register (address 36h) bit description

Legend: * = default value.

Bit	Symbol	Access	Value	Description
7	-	R/W	0*	reserved, must be set to logic 0
6 to 1	B_DA_S[5:0]	R/W		B_DA_S modifies between 50% to 100% the full scale DAC output current. See Section 13.3 .
			00 0000*	minimum current setting
			11 1111	maximum current setting
0	PD_DA_S	R/W		When HIGH, PD_DA_S sets the sound DAC into its Power-down mode.
			0*	Normal mode
			1	sound DAC Power-down mode

Table 52. DAC_REF_CLK_CTL register (address 37h) bit description

Legend: * = default value.

Bit	Symbol	Access	Value	Description
7	-	R/W	0*	not used
6 to 1	-	R/W	10 0000*	reserved, must be set to logic 10 0000
0	PD_DA_REF	R/W		When HIGH, PD_DA_REF sets the reference module into its Power-down mode.
			0*	Normal mode
			1	Power-down mode

9.3.17 Clock generation (PLL and crystal oscillator)

The TDA8296 implements a crystal oscillator which can be used either in Slave mode or in Oscillator mode (see [Section 13.7](#)), and a multipurpose PLL which receives XIN as input clock, and delivers the system clock of the IC (108 MHz).

Table 53. PLL_REG07, PLL_REG08, PLL_REG09 and PLL_REG10 register (address 3Fh to 42h) bit description

Legend: * = default value.

Address	Register	Bit	Symbol	Access	Value	Description
3Fh	PLL_REG07	7	-	R/W	0*	not used
		6	NSEL7	R/W	0*	It programs bit 7 of the N parameter (N = NSEL + 1). N is the PLL pre-divider. See below for bits NSEL[6:0].
		5 to 0	-	R/W	00h*	reserved, must be set to 00h
40h	PLL_REG08	7 to 0	MSEL[7:0]	R/W	1Ah*	It programs the M parameter (M = MSEL + 1). M is the PLL feedback-divider.
41h	PLL_REG09	7 to 1	NSEL[6:0]	R/W	01h*	It programs bits 6 to 0 of the N parameter (N = NSEL + 1). N is the PLL pre-divider.
		0	-	R/W	0*	reserved, must be set to logic 0
42h	PLL_REG10	7 to 5	-	R/W	000*	reserved, must be set to logic 000
		4 to 0	PSEL[4:0]	R/W	01h*	It programs the P parameter (P = PSEL + 1). P is the PLL post-divider.

The PLL output frequency (108 MHz) can be calculated with the following formula:

$$f_{clk(o)(PLL)} = \frac{f_{VCO}}{2 \times P} = \frac{f_i \times M}{N \times P} \tag{1}$$

For optimum performances, the following relations must be respected:

- $275 \text{ MHz} \leq f_{VCO} \leq 550 \text{ MHz}$
- $4 \text{ kHz} \leq f_i / N \leq 150 \text{ MHz}$

9.3.18 GPIOs

In the TDA8296, three general purpose input/outputs are implemented.

Table 54. GPIOREG_0 register (address 44h) bit description

Legend: * = default value.

Bit	Symbol	Access	Value	Description
7 to 4	GP1_CF[3:0]	R/W		It determines how the general purpose pin GPIO1 is configured.
			0000	The GPIO1 pin is in Input mode. The input value is stored in GP1_VAL.
			0001*	The GPIO1 pin is in Open-drain mode. The output value is determined by GP1_VAL.
			0011	The GPIO1 pin is in Output mode. The PLL output clock divided by two is delivered.
			0100 to 1011	The GPIO1 pin is in Output mode. HVPLL signals are delivered. The HVPLL signal is chosen according to Table 56 .
			XXXX	Don't care if I2CSW_EN = 1. Then the pad is configured as I ² C-bus feed-through like described in Table 55 .
3 to 0	GP0_CF[3:0]	R/W		It determines how the general purpose pin GPIO0 is configured.
			0000	The GPIO0 pin is in Input mode. The input value is stored in GP0_VAL.
			0001	The GPIO0 pin is in Open-drain mode. The output value is determined by GP0_VAL.
			0011	The GPIO0 pin is in Output mode. The PLL output clock divided by two is delivered.
			0100 to 1011*	The GPIO0 pin is in Output mode. HVPLL signals are delivered. The HVPLL signal is chosen according to Table 56 .

Table 55. GPIOREG_1 register (address 45h) bit description

Legend: * = default value.

Bit	Symbol	Access	Value	Description
7	I2CSW_EN	R/W	1*	When I2CSW_EN = 1, GPIO1 and GPIO2 are configured as an I ² C-bus feed-through independently of the GP1_CF and GP2_CF value. When I2CSW_ON = 0, the feed-through switch is open, and GPIO1 and GPIO2 are in 3-state. When the switch is closed (I2CSW_ON = 1), the I ² C-bus clock and data signals (SCL and SDA) are available on the GPIO1 and GPIO2 pins.
6	I2CSW_ON	R/W	0*	
5 and 4	-	R/W	00*	not used

Table 55. GPIOREG_1 register (address 45h) bit description ...continued

Legend: * = default value.

Bit	Symbol	Access	Value	Description
3 to 0	GP2_CF[3:0]	R/W		It determines how the general purpose pin GPIO2 is configured.
			0000	The GPIO2 pin is in Input mode. The input value is stored in GP2_VAL.
			0001*	The GPIO2 pin is in Open-drain mode. The output value is determined by GP2_VAL.
			0011	The GPIO2 pin is in Output mode. The PLL output clock divided by two is delivered.
			0100 to 1011	The GPIO2 pin is in Output mode. HVPLL signals are delivered. The HVPLL signal is chosen according to Table 56 .
			XXXX	Don't care if I2CSW_EN = 1. Then the pad is configured as I ² C-bus feed-through.

Table 56. HVPLL signal configuration

HVPLL_BUS bit	Signal
GPx_CF[3:0] = 1011	V_SYNC
GPx_CF[3:0] = 1010	H_SYNC
GPx_CF[3:0] = 1001	NOISE_DET
GPx_CF[3:0] = 1000	MAC_DET
GPx_CF[3:0] = 0111	FIDT
GPx_CF[3:0] = 0110	V_LOCK
GPx_CF[3:0] = 0101	F_H_LOCK
GPx_CF[3:0] = 0100	N_H_LOCK

Table 57. GPIOREG_2 register (address 46h) bit description

Legend: * = default value.

Bit	Symbol	Access	Value	Description
7 to 5	-	R/W	000*	reserved, must be set to logic 000
4 and 3	-	R/W	00*	not used
2	GP2_VAL	R/W	1*	GP2_VAL controls the value of the pin GPIO2 when GP2_CF[3:0] = 0001. When GP2_CF[3:0] = 0000, GPIO2 is an input pin which value can be read through the I ² C-bus stored in GP2_VAL.
1	GP1_VAL	R/W	1*	GP1_VAL controls the value of the pin GPIO1 when GP1_CF[3:0] = 0001. When GP1_CF[3:0] = 0000, GPIO1 is an input pin which value can be read through the I ² C-bus stored in GP1_VAL.
0	GP0_VAL	R/W	1*	GP0_VAL controls the value of the pin GPIO0 when GP0_CF[3:0] = 0001. When GP0_CF[3:0] = 0000, GPIO0 is an input pin which value can be read through the I ² C-bus stored in GP0_VAL.

9.3.19 Special equalizer functions for group delay and video (CVBS)

To realize special customer demands or accurate compensation of the tuner influence, the TDA8296 has got freely programmable equalizers for the group delay and video (CVBS) response.

In [Table 58](#) the programming of the group delay equalizer is explained, in [Table 60](#) the programming of the video equalizer. For each equalizer type an example is given.

Table 58. GD_EQ_SECTx_C1 and GD_EQ_SECTx_C2 (x = 1 to 4) register (address 4Bh to 52h) bit description

Legend: * = default value[1].

Address	Register	Bit	Symbol	Access	Value
4Bh	GD_EQ_SECT1_C1	7 to 0	GD_EQ_SECT1_C1[7:0]	R/W	00h*
4Ch	GD_EQ_SECT1_C2	7 to 0	GD_EQ_SECT1_C2[7:0]	R/W	00h*
4Dh	GD_EQ_SECT2_C1	7 to 0	GD_EQ_SECT2_C1[7:0]	R/W	00h*
4Eh	GD_EQ_SECT2_C2	7 to 0	GD_EQ_SECT2_C2[7:0]	R/W	00h*
4Fh	GD_EQ_SECT3_C1	7 to 0	GD_EQ_SECT3_C1[7:0]	R/W	00h*
50h	GD_EQ_SECT3_C2	7 to 0	GD_EQ_SECT3_C2[7:0]	R/W	00h*
51h	GD_EQ_SECT4_C1	7 to 0	GD_EQ_SECT4_C1[7:0]	R/W	00h*
52h	GD_EQ_SECT4_C2	7 to 0	GD_EQ_SECT4_C2[7:0]	R/W	00h*

[1] Don't care if GD_EQ_CTRL = 0; see [Table 23](#).

Remark: The group delay equalizer consists of four cascaded all-pass Infinite Impulse Response (IIR) sections of second order (8th order in sum). The transfer function H(z) of one section is as follows, while the sampling rate is 13.5 MHz:

$$H(z) = \frac{b_2 + b_1 \times z^{-1} + z^{-2}}{1 + b_1 \times z^{-1} + b_2 \times z^{-2}}$$

GD_EQ_SECTx_C1 and GD_EQ_SECTx_C2 (x = 1 to 4) are defining the linear and square coefficient of each section, i.e. GD_EQ_SECTx_C1 = b₁ and GD_EQ_SECTx_C2 = b₂. The coefficients are in signed fixed-point format, the representation is in two's complement. There is one sign bit, one magnitude bit and 6 fractional bits. Each fractional bit represents an inverse power of two, so that the highest value for a coefficient is 2⁰ + 2⁻¹ + ... + 2⁻⁶ = 2¹ - 2⁻⁶ = 1.984375. The binary representation for this value is 01.11 1111 (= 7Fh) and all bits except the sign bit are logic 1. As two's complement is chosen, the lowest value for a coefficient is -2, which is 10.00 0000 (= 80h) in the binary representation. So, for the lowest possible value, only the sign bit is logic 1. The shown default values for GD_EQ_SECTx_C1 and GD_EQ_SECTx_C2 (x = 1 to 4) implement a flat equalizer response.

Example of [Table 58](#): If e.g. a flat group delay response up to 4 MHz and -70 ns from 4.43 MHz to 5 MHz on the CVBS signal is wanted, one might realize a characteristic like shown in [Figure 17](#).

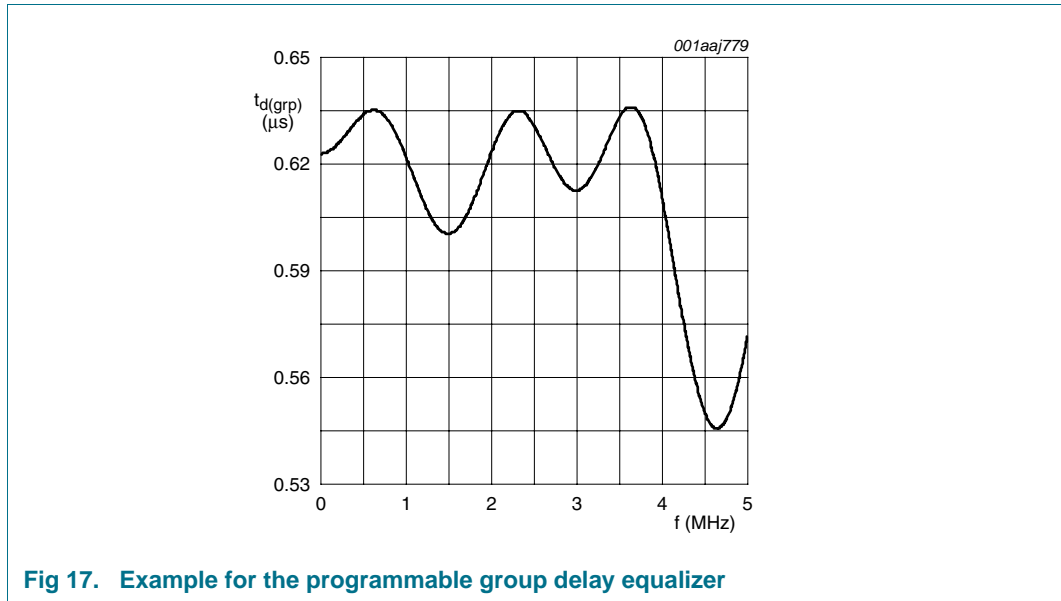

Fig 17. Example for the programmable group delay equalizer

The coefficients used in the above filter are according to [Table 59](#). To get any other filter characteristic use a professional filter tool to determine the coefficients.

Table 59. Coefficients used in group delay equalizer example

Symbol	Value
GD_EQ_SECT1_C1[7:0]	B9h
GD_EQ_SECT1_C2[7:0]	16h
GD_EQ_SECT2_C1[7:0]	DBh
GD_EQ_SECT2_C2[7:0]	17h
GD_EQ_SECT3_C1[7:0]	0Eh
GD_EQ_SECT3_C2[7:0]	19h
GD_EQ_SECT4_C1[7:0]	47h
GD_EQ_SECT4_C2[7:0]	1Ch

Table 60. CVBS_EQ_COEFx_LOW and CVBS_EQ_COEFx_HIGH (x = 0 to 5) register (address 57h to 62h) bit description

Legend: * = default value^[1].

Address	Register	Bit	Symbol	Access	Value
57h	CVBS_EQ_COEF0_LOW	7 to 0	CVBS_EQ_COEF0[7:0]	R/W	00h*
58h	CVBS_EQ_COEF0_HIGH	7 to 4	-	R/W	0000*
		3 to 0	CVBS_EQ_COEF0[11:8]	R/W	0h*
59h	CVBS_EQ_COEF1_LOW	7 to 0	CVBS_EQ_COEF1[7:0]	R/W	00h*
5Ah	CVBS_EQ_COEF1_HIGH	7 to 4	-	R/W	0000*
		3 to 0	CVBS_EQ_COEF1[11:8]	R/W	0h*
5Bh	CVBS_EQ_COEF2_LOW	7 to 0	CVBS_EQ_COEF2[7:0]	R/W	00h*
5Ch	CVBS_EQ_COEF2_HIGH	7 to 4	-	R/W	0000*
		3 to 0	CVBS_EQ_COEF2[11:8]	R/W	0h*
5Dh	CVBS_EQ_COEF3_LOW	7 to 0	CVBS_EQ_COEF3[7:0]	R/W	00h*

Table 60. CVBS_EQ_COEFx_LOW and CVBS_EQ_COEFx_HIGH (x = 0 to 5) register (address 57h to 62h) bit description ...continued

Legend: * = default value[1].

Address	Register	Bit	Symbol	Access	Value
5Eh	CVBS_EQ_COEF3_HIGH	7 to 4	-	R/W	0000*
		3 to 0	CVBS_EQ_COEF3[11:8]	R/W	0h*
5Fh	CVBS_EQ_COEF4_LOW	7 to 0	CVBS_EQ_COEF4[7:0]	R/W	00h*
60h	CVBS_EQ_COEF4_HIGH	7 to 4	-	R/W	0000*
		3 to 0	CVBS_EQ_COEF4[11:8]	R/W	0h*
61h	CVBS_EQ_COEF5_LOW	7 to 0	CVBS_EQ_COEF5[7:0]	R/W	00h*
62h	CVBS_EQ_COEF5_HIGH	7 to 4	-	R/W	0000*
		3 to 0	CVBS_EQ_COEF5[11:8]	R/W	4h*

[1] Don't care if CVBS_EQ_CTRL = 0; see [Table 32](#).

Remark: The overall video (CVBS) equalizer is a symmetric FIR filter with 11 taps. Due to the symmetry the group delay is constant (linear phase). The transfer function is as follows, while the sampling rate is 13.5 MHz:

$$H(z) = h_0 + h_1 \times z^{-1} + h_2 \times z^{-2} + h_3 \times z^{-3} + h_4 \times z^{-4} + \dots + h_{10} \times z^{-10}$$

Please note that because of the symmetry $h_0 = h_{10}$, $h_1 = h_9$, $h_2 = h_8$, $h_3 = h_7$ and $h_4 = h_6$. The mid coefficient h_5 is only present once. CVBS_EQ_COEFx (x = 0 to 5) are defining the coefficients, i.e. CVBS_EQ_COEF0 = $h_0 = h_{10}$, CVBS_EQ_COEF1 = $h_1 = h_9$, CVBS_EQ_COEF2 = $h_2 = h_8$, CVBS_EQ_COEF3 = $h_3 = h_7$, CVBS_EQ_COEF4 = $h_4 = h_6$ and CVBS_EQ_COEF5 = h_5 . Each of the coefficients h_0 to h_5 has got 12-bit quantization. The coefficients are in signed fixed-point format, the representation is in two's complement. There is one sign bit, one magnitude bit and 10 fractional bits. Each fractional bit represents an inverse power of two, so that the highest value for a coefficient is $2^0 + 2^{-1} + \dots + 2^{-10} = 2^1 - 2^{-10} = 1.9990234375$. The binary representation for this value is 01.11 1111 1111 (= 7FFh) and all bits except the sign bit are logic 1. As two's complement is chosen, the lowest value for a coefficient is -2, which is 10.00 0000 0000 (= 800h) in the binary representation. So, for the lowest possible value, only the sign bit is logic 1. The shown default values for CVBS_EQ_COEFx (x = 0 to 5) implement a flat equalizer response.

Example of [Table 60](#): If an attenuation of around 1 dB for video frequencies greater than 2 MHz is wanted, the following figure (see [Figure 18](#)) can be implemented.

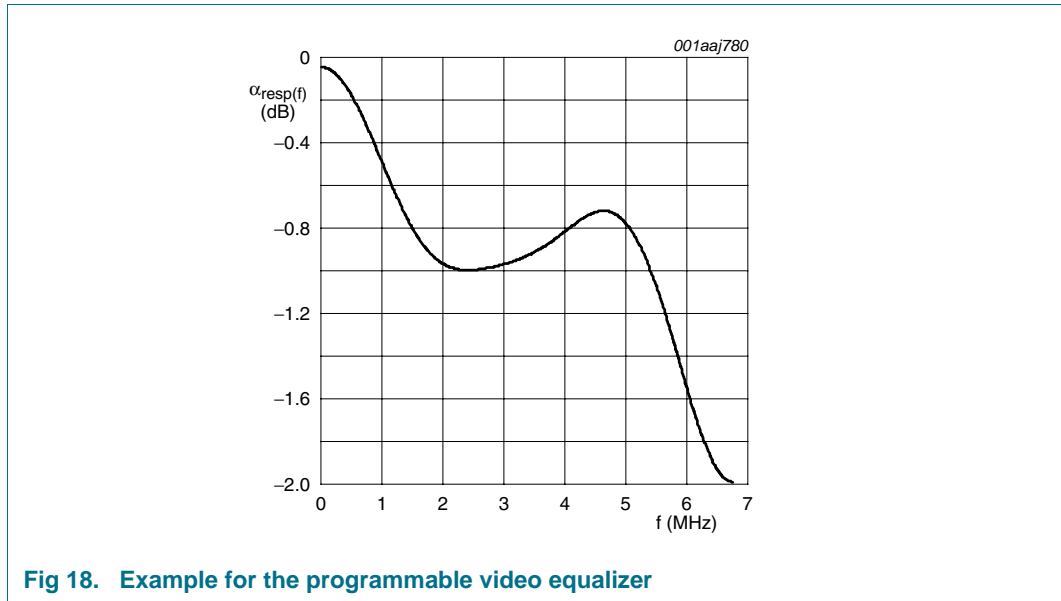

Fig 18. Example for the programmable video equalizer

Table 61. Coefficients used in video equalizer example

Symbol	Value
CVBS_EQ_COEF0[11:0]	005h
CVBS_EQ_COEF1[11:0]	FFDh
CVBS_EQ_COEF2[11:0]	016h
CVBS_EQ_COEF3[11:0]	FFFh
CVBS_EQ_COEF4[11:0]	018h
CVBS_EQ_COEF5[11:0]	39Ch

10. Limiting values

Table 62. Limiting values

In accordance with the Absolute Maximum Rating System (IEC 60134).^{[1][2][3]}

Symbol	Parameter	Conditions	Min	Max	Unit
V _{DD(1V2)}	digital supply voltage (1.2 V)		-0.5	+1.5	V
V _{DDDR(3V3)}	ring digital supply voltage (3.3 V)		-0.5	+4.6	V
V _{DDA(ADC)(1V2)}	ADC analog supply voltage (1.2 V)		-0.5	+1.5	V
V _{DDA(PLL)(1V2)}	PLL analog supply voltage (1.2 V)		-0.5	+1.5	V
V _{DDA(DAC)(3V3)}	DAC analog supply voltage (3.3 V)		-0.5	+4.6	V
V _i	input voltage	pins XIN, IF_POS and IF_NEG	-0.5	+1.3	V
		digital input pins	-0.5	+4.6	V
T _{lead}	lead temperature		-	300	°C
P _{tot}	total power dissipation	T _{amb} = 85 °C	-	0.5	W
T _{stg}	storage temperature		-40	+125	°C
T _j	junction temperature		-	+125	°C
T _{amb}	ambient temperature		-20	+85	°C
V _{ESD}	electrostatic discharge voltage	all pins:			
		Field ind. Charge Device Model (FCDM)	^[4] -	±1000	V
		Human Body Model (HBM)	-	±4000	V

- [1] Stresses above the absolute maximum ratings may cause permanent damage to the device. Exposure to absolute maximum ratings conditions for extended periods may affect device reliability.
- [2] T_j depends on the assembly condition of the package and especially on the design of the PCB. The application mounting must be done in such a way that the maximum junction temperature T_{j(max)} is never exceeded.
- [3] No power sequence requirement
- [4] Class IV according to EIA/JESD22-C101.

11. Thermal characteristics

Table 63. Thermal characteristics

Symbol	Parameter	Conditions	Typ	Unit
R _{th(j-a)}	thermal resistance from junction to ambient	in still air	36.8	K/W

The thermal resistance depends strongly on the nature of the PCB used in the application and on its design. The thermal resistance given in [Table 63](#) corresponds to the value that can be measured on a multilayer PCB (4 layers) as defined by EIA/JESD51-2. This value is given for information only.

The junction temperature influences strongly the reliability of an IC. The PCB used in the application contributes on a large part to the overall thermal characteristic. It must therefore be designed to insure that the junction temperature of the IC never exceeds T_{j(max)} = 125 °C at the maximum ambient temperature.

The IC has to be soldered to ground with its die-attached paddle. Plenty of vias are recommended to remove the heat.

12. Characteristics

Table 64. Characteristics

Power supplies 3.3 V, 1.2 V; $T_{amb} = 25\text{ °C}$; PC/SC1 for L and M = 10 dB, all others 13 dB; nominal residual picture carrier of 3 % for L/L', 10 % for M, 10 % for B/G, 12.5 % for D/K, 20 % for I; FM/AM modulation = 54 %, 1 kHz modulation frequency; measured in application PCB (see [Figure 22](#) and [Figure 23](#)) with 16 MHz crystal frequency, terminated with $75\ \Omega$ (CVBS) and $1\ k\Omega$ (SSIF/audio). Operation mode set via easy programming ([Section 9.3.1](#)), otherwise stated. Low IF input signal at -3dB full scale, input frequencies as defined under row header IF input.

Symbol	Parameter	Conditions	Min	Typ	Max	Unit
Power supply						
$V_{DD(1V2)}$	supply voltage (1.2 V)	digital and analog	1.1	1.2	1.3	V
$V_{DD(3V3)}$	supply voltage (3.3 V)	digital and analog	3.0	3.3	3.6	V
$I_{DD(tot)(1V2)}$	total supply current (1.2 V)		-	49	-	mA
$I_{DD(tot)(3V3)}$	total supply current (3.3 V)		-	65	-	mA
P_{tot}	total power dissipation	default settings; $f_s = 54\text{ MHz}$ at ADC; DAC application in accordance to Figure 23	-	270	-	mW
		$f_s = 54\text{ MHz}$ at ADC; DAC application in accordance to Figure 24	-	150	-	mW
		Standby mode	-	5	8	mW
Digital I/Os						
V_{IH}	HIGH-level input voltage	all inputs (except pin XIN); including voltage on outputs in 3-state mode	$0.7 \times V_{DD(3V3)}$	-	6.0	V
V_{IL}	LOW-level input voltage	all inputs (except pin XIN); including voltage on outputs in 3-state mode	-	-	0.8	V
V_{OH}	HIGH-level output voltage	source current 4 mA	$V_{DD(3V3)} - 0.4$	-	-	V
V_{OL}	LOW-level output voltage	sink current 4 mA	-	-	0.4	V
C_i	input capacitance		-	-	5	pF
Master clock						
$f_{clk(o)(PLL)}$	PLL output clock frequency		[1]	108	-	MHz
$\Delta f/f_{clk}$	relative frequency deviation from clock frequency		-	-	± 200	10^{-6}
Reference frequency in Slave mode						
$f_{clk(ext)}$	external clock frequency		-	16	-	MHz
$V_{i(RMS)}$	RMS input voltage	AC coupled	200	250	-	mV
SR_r	rising slew rate	external clock	30	-	-	mV/ns
$t_{jit(cc)}$	cycle-to-cycle jitter time	RMS value	-	12.5	-	ps
C_i	input capacitance	on pin XIN	-	3	-	pF

Table 64. Characteristics ...continued

Power supplies 3.3 V, 1.2 V; $T_{amb} = 25\text{ }^{\circ}\text{C}$; PC/SC1 for L and M = 10 dB, all others 13 dB; nominal residual picture carrier of 3 % for L/L', 10 % for M, 10 % for B/G, 12.5 % for D/K, 20 % for I; FM/AM modulation = 54 %, 1 kHz modulation frequency; measured in application PCB (see [Figure 22](#) and [Figure 23](#)) with 16 MHz crystal frequency, terminated with 75 Ω (CVBS) and 1 k Ω (SSIF/audio). Operation mode set via easy programming ([Section 9.3.1](#)), otherwise stated. Low IF input signal at -3dB full scale, input frequencies as defined under row header IF input.

Symbol	Parameter	Conditions	Min	Typ	Max	Unit
Reference frequency in Oscillator mode (with a crystal)						
f_{xtal}	crystal frequency		-	16	-	MHz
$\Delta f_{xtal}/f_{xtal}$	relative crystal frequency variation	temperature, ageing and spreading	-	-	± 200	10^{-6}
IF input						
$V_{i(p-p)}$	peak-to-peak input voltage	for full-scale ADC input (0 dBFS)	0.7	0.8	0.9	V
$R_{i(dif)}$	differential input resistance		10	15	-	k Ω
$C_{i(dif)}$	differential input capacitance		-	2	3	pF
V_i	input voltage	operational input related to ADC full scale; all standards; sum of all signals	-3	-3	-3	dBFS
f_i	input frequency	PC / SC1				
		M/N standard	-	5.40 / 0.90	-	MHz
		B standard	-	6.40 / 0.90	-	MHz
		G/H standard	-	6.75 / 1.25	-	MHz
		I standard	-	7.25 / 1.25	-	MHz
		D/K standard	-	6.85 / 0.35	-	MHz
		L standard	-	6.75 / 0.25	-	MHz
		L-accent standard	-	1.25 / 7.75	-	MHz
		FM radio	-	1.25	-	MHz
IF selectivity						
$\alpha_{sup(stpb)}$	stop-band suppression	Hilbert filter stop-band	-60	-	-	dB
		decimation filter stop-band	-40	-	-	dB
		notch for NSC (NPC for L-accent standard)	[2] -40	-	-	dB
Carrier recovery FPLL						
$B_{-3dB(cl)}$	closed-loop -3 dB bandwidth	ultrawide	-	280	-	kHz
		superwide	-	130	-	kHz
		wide	-	60	-	kHz
		medium	-	30	-	kHz
		narrow	-	15	-	kHz
Δf_{pullin}	pull-in frequency range		[3] -	± 830	-	kHz
$m_{over(PC)}$	picture carrier over modulation index	black for L/L-accent standard; flat field white else	115	117	-	%
$f_{step(AFC)}$	AFC step frequency	128 steps	[3] 13	-	-	kHz

Table 64. Characteristics ...continued

Power supplies 3.3 V, 1.2 V; $T_{amb} = 25\text{ }^{\circ}\text{C}$; PC/SC1 for L and M = 10 dB, all others 13 dB; nominal residual picture carrier of 3 % for L/L', 10 % for M, 10 % for B/G, 12.5 % for D/K, 20 % for I; FM/AM modulation = 54 %, 1 kHz modulation frequency; measured in application PCB (see [Figure 22](#) and [Figure 23](#)) with 16 MHz crystal frequency, terminated with 75 Ω (CVBS) and 1 k Ω (SSIF/audio). Operation mode set via easy programming ([Section 9.3.1](#)), otherwise stated. Low IF input signal at -3dB full scale, input frequencies as defined under row header IF input.

Symbol	Parameter	Conditions	Min	Typ	Max	Unit
IF demodulation (video equalizer in Flat mode)						
$B_{T(tot)}$	total transition bandwidth	Nyquist filter; all standards	-	1	-	MHz
$\alpha_{sup(stpb)}$	stop-band suppression	Nyquist filter; all standards	-60	-	-	dB
		video low-pass filter (M/N, B/G/H, I, D/K, L/L-accent standard)	-	-60	-	dB
$B_{video(-1dB)}$	-1 dB video bandwidth	M/N standard	-	3.8	-	MHz
		B/G/H, I, D/K, L/L-accent standard	-	4.8	-	MHz
$t_{ripple(GDE)}$	group delay equalizer ripple time	peak value for B/G/H half, D/K half, I flat, M (FCC) full, L/L-accent full standard	-	20	40	ns
Digital IF AGC (internal loop)						
$B_{-3dB(cl)}$	closed-loop -3 dB bandwidth	negative modulation (all standards except L/L-accent)	[4] 400	-	-	Hz
		positive modulation (L/L-accent standard)	0.2	-	-	Hz
t_{resp}	response time	± 20 dB level change; video settled within ± 3 dB				
		negative modulation (all standards except L/L-accent)	-	3	-	ms
		positive modulation (L/L-accent standard)	-	100	-	ms
ΔG_{AGC}	AGC gain range		-20	-	+48	dB
Tuner IF AGC (external loop)						
t_{resp}	response time	at 60 dB μ V (RMS) PC input; ± 20 dB level change; video settled within ± 3 dB	[5]			
		with TDA1827x; positive modulation	-	3000	-	ms
		with TDA1827x; negative modulation	-	600	-	ms
$f_{-3dB(lpf)}$	low-pass filter -3 dB frequency	IF AGC postfilter	0.9	1.0	1.1	kHz

Table 64. Characteristics ...continued

Power supplies 3.3 V, 1.2 V; $T_{amb} = 25\text{ }^{\circ}\text{C}$; PC/SC1 for L and M = 10 dB, all others 13 dB; nominal residual picture carrier of 3 % for L/L', 10 % for M, 10 % for B/G, 12.5 % for D/K, 20 % for I; FM/AM modulation = 54 %, 1 kHz modulation frequency; measured in application PCB (see [Figure 22](#) and [Figure 23](#)) with 16 MHz crystal frequency, terminated with 75 Ω (CVBS) and 1 k Ω (SSIF/audio). Operation mode set via easy programming ([Section 9.3.1](#)), otherwise stated. Low IF input signal at -3dB full scale, input frequencies as defined under row header IF input.

Symbol	Parameter	Conditions	Min	Typ	Max	Unit	
CVBS output							
$V_{o(p-p)}$	peak-to-peak output voltage	negative PC modulation (all standards except L/L-accent); 75 Ω DC load; sync-white modulation					
		65 %	-	0.7	-	V	
		nominal	0.9	1.0	1.1	V	
		115 %	-	1.0	-	V	
		positive PC modulation (L/L-accent standard); 75 Ω DC load; sync-white modulation					
		65 %	-	0.7	-	V	
$B_{\text{video}(-3\text{dB})}$	-3 dB video bandwidth	overall video response; CVBS equalizer flat					
		all standards except M/N	4.7	4.85	-	MHz	
		M/N standard	3.8	3.9	-	MHz	
$\alpha_{\text{resp}(f)}$	frequency response	video equalizer; 8 equally spaced settings; value at 3.9 MHz	-5	-	+4.5	dB	
G_{dif}	differential gain	"ITU-T J.63 line 330"	[6] -	1.5	5	%	
φ_{dif}	differential phase	"ITU-T J.63 line 330"	-	1.0	3	deg	
$V_{\text{video}}/V_{\text{sync}}$	video voltage to sync voltage ratio	video DAC application according to Figure 23	1.9	2.33	3.0		
V_{sync}	synchronization voltage	video DAC application according to Figure 23	160	200	240	mV	
$V_{\text{stilt}}/V_{\text{CVBS}(p-p)}$	synchronization tilt voltage to peak-to-peak CVBS voltage ratio		-	1	2	%	
$V_{\text{fitt}}/V_{\text{CVBS}(p-p)}$	frame tilt voltage to peak-to-peak CVBS voltage ratio	all standards except L/L-accent	-	1	3	%	
		L/L-accent standard in peak white AGC detection	-	1	5	%	
$\Delta V_{\text{tro}}/V_{\text{tro}}$	relative transient response overshoot voltage variation	2T pulse	[7] -	2	5	%	

Table 64. Characteristics ...continued

Power supplies 3.3 V, 1.2 V; $T_{amb} = 25\text{ }^{\circ}\text{C}$; PC/SC1 for L and M = 10 dB, all others 13 dB; nominal residual picture carrier of 3 % for L/L', 10 % for M, 10 % for B/G, 12.5 % for D/K, 20 % for I; FM/AM modulation = 54 %, 1 kHz modulation frequency; measured in application PCB (see [Figure 22](#) and [Figure 23](#)) with 16 MHz crystal frequency, terminated with $75\ \Omega$ (CVBS) and $1\ \text{k}\Omega$ (SSIF/audio). Operation mode set via easy programming ([Section 9.3.1](#)), otherwise stated. Low IF input signal at -3dB full scale, input frequencies as defined under row header IF input.

Symbol	Parameter	Conditions	Min	Typ	Max	Unit	
$\alpha_{IM(\text{blue})}$	intermodulation suppression (blue)	carrier levels related to PC sync; PC = -3.2 dB; CC = -19.2 dB; SC = -13 dB					
		1.1 MHz (related to black-to-white in RMS, equals CC + 3.6 dB)	-	67	-	dB	
		3.3 MHz (related to CC)	-	77	-	dB	
$\alpha_{IM(\text{yellow})}$	intermodulation suppression (yellow)	carrier levels related to PC sync; PC = -10 dB; CC = -19.2 dB; SC = -13 dB					
		1.1 MHz (related to black-to-white in RMS, equals CC + 3.6 dB)	-	70	-	dB	
		3.3 MHz (related to CC)	-	78	-	dB	
$(S/N)_w$	weighted signal-to-noise ratio	all standards; unified weighting filter ("ITU-T J.61"); PC at -6 dBFS	57	60	-	dB	
PSRR	power supply rejection ratio	$f_{\text{ripple}} = 70\ \text{Hz}$; 100 mV (p-p); video signal: gray; level: 50 %; TDA8296 stand alone; input					
		positive video modulation; L standard; 1.2 V	-	39	-	dB	
		positive video modulation; L standard; 3.3 V	[8]	-	47	-	dB
		negative video modulation; B standard; 1.2 V	-	65	-	dB	
		negative video modulation; B standard; 3.3 V	[8]	-	37	-	dB
$\alpha_{\text{sup}(f)L(\text{unw})}$	unwanted leakage frequency suppression	4.8 MHz video modulation; related to black-to-white in 10 MHz to 200 MHz band, wanted signal (peak-to-peak) and unwanted signal (RMS)	-	56	-	dB	

Table 64. Characteristics ...continued

Power supplies 3.3 V, 1.2 V; $T_{amb} = 25\text{ }^{\circ}\text{C}$; PC/SC1 for L and M = 10 dB, all others 13 dB; nominal residual picture carrier of 3 % for L/L', 10 % for M, 10 % for B/G, 12.5 % for D/K, 20 % for I; FM/AM modulation = 54 %, 1 kHz modulation frequency; measured in application PCB (see [Figure 22](#) and [Figure 23](#)) with 16 MHz crystal frequency, terminated with 75 Ω (CVBS) and 1 k Ω (SSIF/audio). Operation mode set via easy programming ([Section 9.3.1](#)), otherwise stated. Low IF input signal at -3dB full scale, input frequencies as defined under row header IF input.

Symbol	Parameter	Conditions	Min	Typ	Max	Unit
SSIF/mono sound output						
$f_{o(SSIF)}$	SSIF output frequency	SC1 or FM radio carrier	[9]			
		M standard	-	4.5	-	MHz
		B/G/H standard	-	5.5	-	MHz
		I standard	-	6.0	-	MHz
		D/K/L/L-accent standard	-	6.5	-	MHz
		FM radio	-	5.5	-	MHz
$V_{o(SSIF)(RMS)}$	RMS SSIF output voltage	1 k Ω DC or AC load; no modulation; PC / SC1 = 13 dB; Cs = 220 pF				
		M standard	105	120	135	mV
		B standard	100	115	130	mV
		G/H standard	100	115	130	mV
		D/K standard	95	110	125	mV
		I standard	100	115	130	mV
		L standard	95	110	125	mV
		L-accent standard	95	110	125	mV
		FM radio (single carrier)	100	115	130	mV
$V_{o(AF)(RMS)}$	RMS AF output voltage	1 k Ω DC or AC load; FM; gain 0 dB				
		M standard; 54 % modulation degree (± 13.5 kHz FM deviation before pre-emphasis)	98	126	135	mV
		B, G/H, I, D/K standard; 54 % modulation degree (± 27 kHz FM deviation before pre-emphasis)	107	133	144	mV
		L/L-accent standard; AM; m = 54 %; gain +6 dB	158	176	196	mV
		FM radio; 30 % modulation degree (± 22.5 kHz FM deviation before pre-emphasis)	51	54	60	mV
		high Deviation mode (D/K standard China); FM deviation before pre-emphasis ± 400 kHz; sound level setting: -12 dB	[10] -	425	-	mV

Table 64. Characteristics ...continued

Power supplies 3.3 V, 1.2 V; $T_{amb} = 25\text{ °C}$; PC/SC1 for L and M = 10 dB, all others 13 dB; nominal residual picture carrier of 3 % for L/L', 10 % for M, 10 % for B/G, 12.5 % for D/K, 20 % for I; FM/AM modulation = 54 %, 1 kHz modulation frequency; measured in application PCB (see [Figure 22](#) and [Figure 23](#)) with 16 MHz crystal frequency, terminated with 75 Ω (CVBS) and 1 k Ω (SSIF/audio). Operation mode set via easy programming ([Section 9.3.1](#)), otherwise stated. Low IF input signal at -3dB full scale, input frequencies as defined under row header IF input.

Symbol	Parameter	Conditions	Min	Typ	Max	Unit
$\alpha_{hr(AF)}$	AF headroom	before clipping; 1 k Ω DC or AC load				
		M standard; related to ± 25 kHz peak deviation before pre-emphasis	-	7	-	dB
		B, G/H, I, D/K standard; related to ± 50 kHz peak deviation before pre-emphasis	-	7	-	dB
		L/L-accent standard; PC / SC1 ratio for start of audio output clipping; AM; m = 100 %; related to mean SC1	-	9	-	dB
		FM radio; 30 % modulation degree related to ± 22.5 kHz peak deviation before pre-emphasis	-	9	-	dB
τ_{deemp}	de-emphasis time constant	M/N standard (mono); FM radio USA	-	75	-	μ s
		B/G/H, I, D/K standard; FM radio Europe	-	50	-	μ s
B_{-3dB}	-3 dB bandwidth	audio low-pass filter				
		L/L-accent standard	-	30	-	kHz
		M-BTSC standard	-	140	-	kHz
THD	total harmonic distortion	FM; for 50 kHz deviation before pre-emphasis (25 kHz for M standard)	-	0.15	0.3	%
		AM; m = 80 %	-	0.5	1	%
$B_{AF(-3dB)}$	-3 dB AF bandwidth	AM	20	27	-	kHz
		FM	40	50	-	kHz
α_{AM}	AM suppression	of FM demodulator; AM: f = 1 kHz; m = 54 % referenced to 27 kHz FM deviation	40	51	-	dB

Table 64. Characteristics ...continued

Power supplies 3.3 V, 1.2 V; $T_{amb} = 25\text{ }^{\circ}\text{C}$; PC/SC1 for L and M = 10 dB, all others 13 dB; nominal residual picture carrier of 3 % for L/L', 10 % for M, 10 % for B/G, 12.5 % for D/K, 20 % for I; FM/AM modulation = 54 %, 1 kHz modulation frequency; measured in application PCB (see [Figure 22](#) and [Figure 23](#)) with 16 MHz crystal frequency, terminated with 75 Ω (CVBS) and 1 k Ω (SSIF/audio). Operation mode set via easy programming ([Section 9.3.1](#)), otherwise stated. Low IF input signal at -3dB full scale, input frequencies as defined under row header IF input.

Symbol	Parameter	Conditions	Min	Typ	Max	Unit	
$(S/N)_{w(AF)}$	AF weighted signal-to-noise ratio	via internal mono sound demodulator; "ITU-R BS.468-4"; FM mode related to 27 kHz deviation before pre-emphasis; 10 % residual PC; SC1					
		black picture	52	54	-	dB	
		flat field white picture	52	54	-	dB	
		6 kHz sine wave picture	52	54	-	dB	
		250 kHz square wave picture	52	54	-	dB	
		crosshatch picture	52	54	-	dB	
		color bar picture	52	54	-	dB	
		via internal mono sound demodulator; (audio gain +6 dB) "ITU-R BS.468-4"; AM; m = 54 %; 3 % residual PC; SC1					
		black picture	40	44	-	dB	
		flat field white picture	41	44	-	dB	
		color bar picture	40	44	-	dB	
		via internal mono sound demodulator; "ITU-R BS.468-4"; FM Radio mode; 22.5 kHz deviation					
			-	45	-	dB	

Table 64. Characteristics ...continued

Power supplies 3.3 V, 1.2 V; $T_{amb} = 25\text{ °C}$; PC/SC1 for L and M = 10 dB, all others 13 dB; nominal residual picture carrier of 3 % for L/L', 10 % for M, 10 % for B/G, 12.5 % for D/K, 20 % for I; FM/AM modulation = 54 %, 1 kHz modulation frequency; measured in application PCB (see [Figure 22](#) and [Figure 23](#)) with 16 MHz crystal frequency, terminated with $75\ \Omega$ (CVBS) and $1\text{ k}\Omega$ (SSIF/audio). Operation mode set via easy programming ([Section 9.3.1](#)), otherwise stated. Low IF input signal at -3dB full scale, input frequencies as defined under row header IF input.

Symbol	Parameter	Conditions	Min	Typ	Max	Unit		
$(S/N)_{w(SC1)}$	first sound carrier weighted signal-to-noise ratio	via external SSIF sound demodulator in Dual mode; "ITU-R BS.468-4"; FM mode related to 27 kHz deviation before pre-emphasis; 10 % residual PC						
		black picture	-	58	-	dB		
		flat field white picture	-	57	-	dB		
		6 kHz sine wave picture	-	57	-	dB		
		250 kHz square wave picture	-	58	-	dB		
		crosshatch picture	-	52	-	dB		
		color bar picture	-	58	-	dB		
		via SSIF sound demodulator; "ITU-R BS.468-4"; AM; m = 54 %; 3 % residual PC						
		black picture	-	44	-	dB		
		flat field white picture	-	44	-	dB		
		color bar picture	-	44	-	dB		
		$(S/N)_{w(SC2)}$	second sound carrier weighted signal-to-noise ratio	via external SSIF sound demodulator in Dual mode; "ITU-R BS.468-4"; FM mode related to 27 kHz deviation before pre-emphasis; 10 % residual PC				
				black picture	-	56	-	dB
flat field white picture	-			55	-	dB		
6 kHz sine wave picture	-			55	-	dB		
250 kHz square wave picture	-			51	-	dB		
crosshatch picture	-			51	-	dB		
color bar picture	-			56	-	dB		
$(S/N)_w$	weighted signal-to-noise ratio	FM radio; via SSIF sound demodulator in Mono mode; "ITU-R BS.468-4"; 22.5 kHz deviation	-	55	-	dB		

Table 64. Characteristics ...continued

Power supplies 3.3 V, 1.2 V; $T_{amb} = 25\text{ °C}$; PC/SC1 for L and M = 10 dB, all others 13 dB; nominal residual picture carrier of 3 % for L/L', 10 % for M, 10 % for B/G, 12.5 % for D/K, 20 % for I; FM/AM modulation = 54 %, 1 kHz modulation frequency; measured in application PCB (see [Figure 22](#) and [Figure 23](#)) with 16 MHz crystal frequency, terminated with 75 Ω (CVBS) and 1 k Ω (SSIF/audio). Operation mode set via easy programming ([Section 9.3.1](#)), otherwise stated. Low IF input signal at -3dB full scale, input frequencies as defined under row header IF input.

Symbol	Parameter	Conditions	Min	Typ	Max	Unit	
PSRR	power supply rejection ratio	$f_{ripple} = 70\text{ Hz}$; 100 mV (p-p); video signal: gray; level: 50 %; TDA8296 stand alone					
		FM sound; 1.2 V	-	80	-	dB	
		FM sound; 3.3 V	[8]	-	39	-	dB
		AM sound; 1.2 V	-	40	-	dB	
		AM sound; 3.3 V	[8]	-	38	-	dB
$\alpha_{sup(f)L(unw)}$	unwanted leakage frequency suppression	related to SSIF (SC1) in 10 MHz to 200 MHz band wanted signal (peak-to-peak) and unwanted signal (RMS)	-	51	-	dB	

- [1] See [Section 9.3.17](#) for PLL setting.
- [2] Standard dependent located at 6.9 MHz, 7.9 MHz, 8.3 MHz and 9.25 MHz.
- [3] The pull-in range can be doubled to $\pm 1\,660\text{ kHz}$ by I²C-bus register like described in [Table 16](#). Then the AFC read-out has 256 steps.
- [4] To counteract a fast IF level reduction, the digital IF AGC loop has a speed-up circuit for positive video modulation.
- [5] In the ordinary system application, this slow response is counteracted by the fast digital IF AGC loop. ADC clipping is practically avoided by fast-attack AGC characteristic.
- [6] Graph differential gain versus temperature.
- [7] HAD: 250 ns for M standard, 200 ns for others.
- [8] The values given are measured with an IF AGC time constant of 5 Hz. For that, capacitor C7 in [Figure 19](#) must be chosen 220 nF instead of 2.2 nF. Doing so, the PSRR on 3.3 V together with the tuner can be improved.
- [9] SC2 is not listed, but supported for all world standards.
- [10] At high deviation mode at D/K standard, IF frequency has to be programmed, that SIF frequency is higher than 500 kHz (default: 350 kHz).
- [11] To set audio gain to +6 dB for internal sound demodulation, register 22h has to be programmed to 08h.

13. Application information

13.1 Typical application

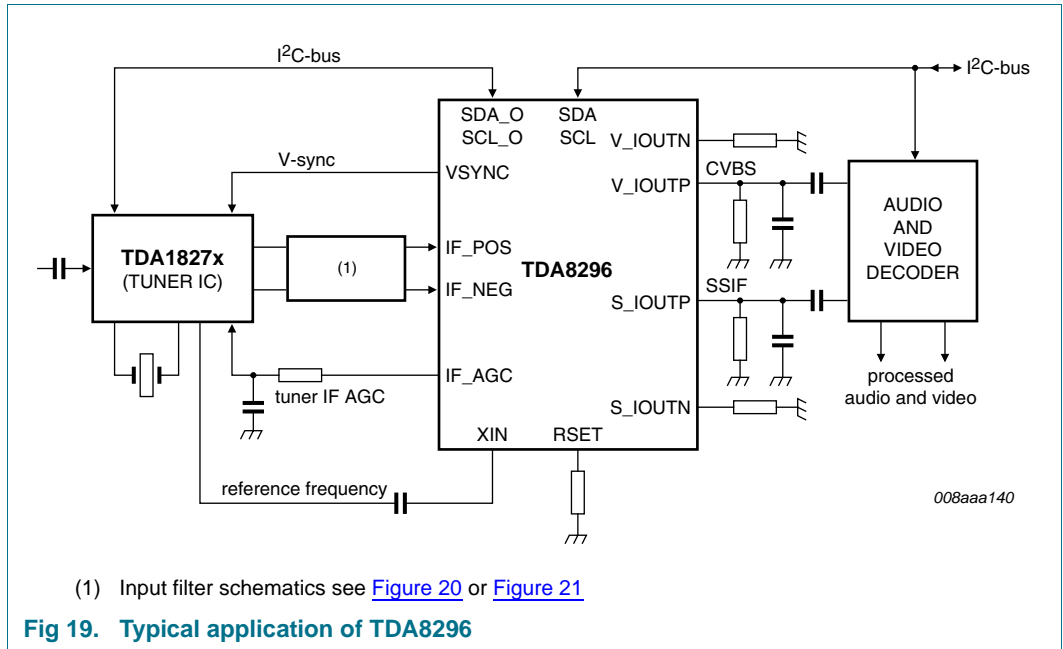

13.1.1 IF input application

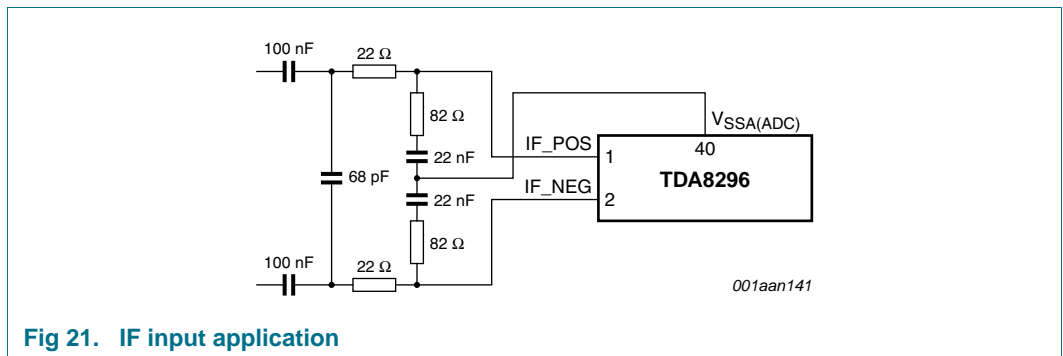
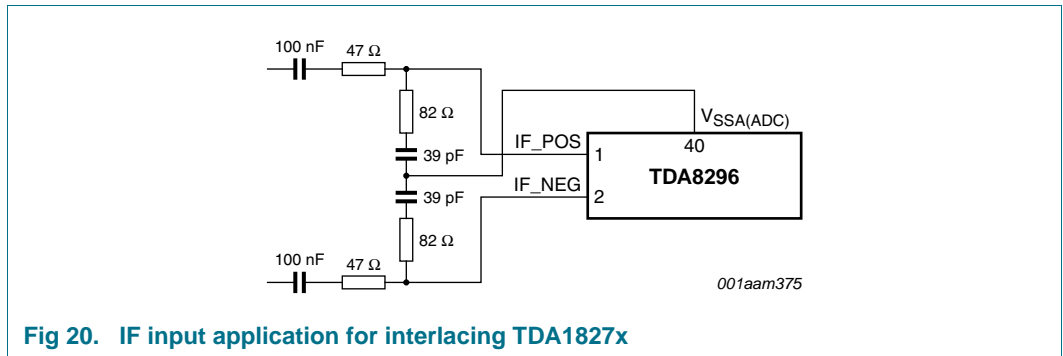

13.2 Detailed application diagrams

13.2.1 Main application diagram

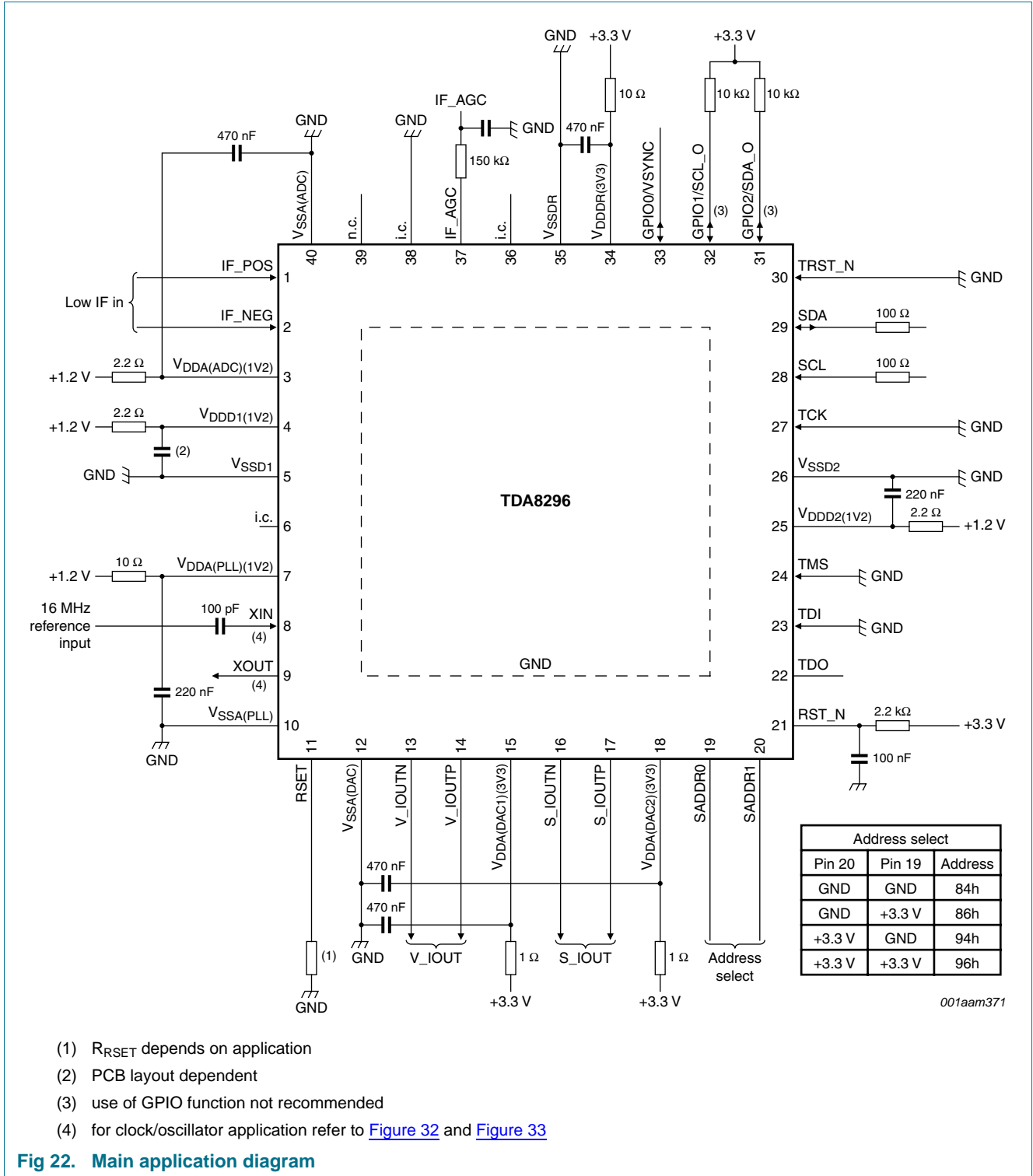

- (1) R_{RSET} depends on application
- (2) PCB layout dependent
- (3) use of GPIO function not recommended
- (4) for clock/oscillator application refer to [Figure 32](#) and [Figure 33](#)

Fig 22. Main application diagram

13.2.2 75 Ω application

This is the reference application for the data sheet characteristic.

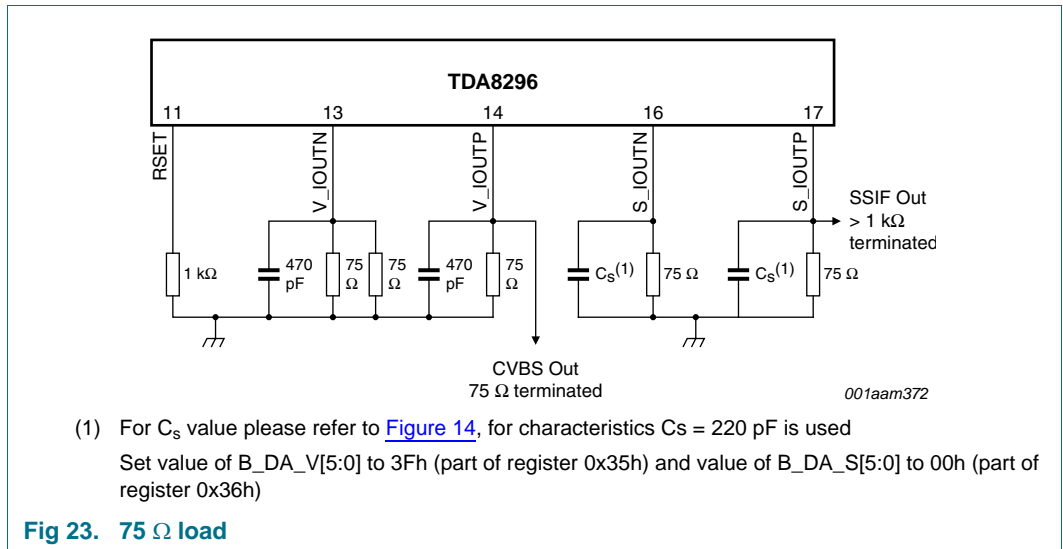

13.2.3 100 Ω application

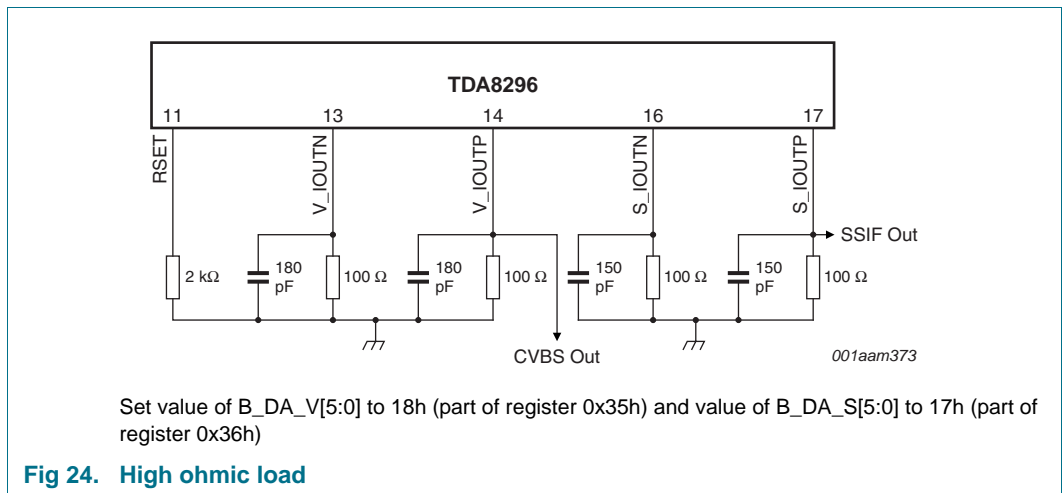

13.2.4 Buffer application

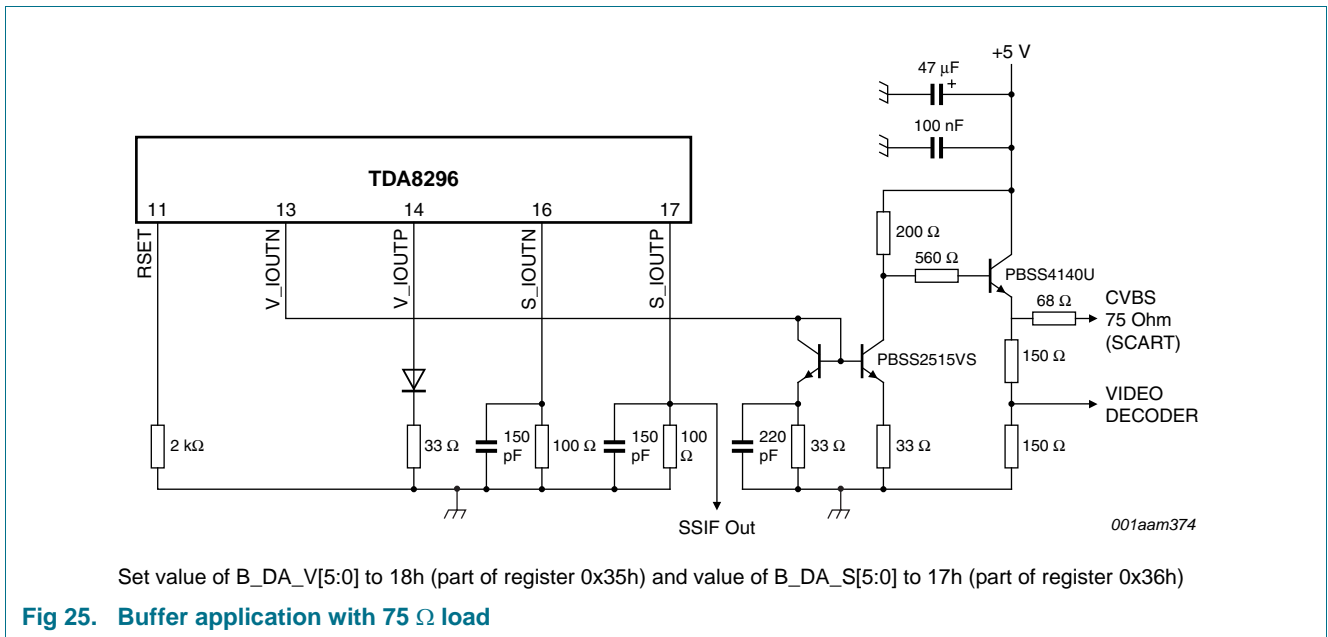

13.2.5 Layout recommendations

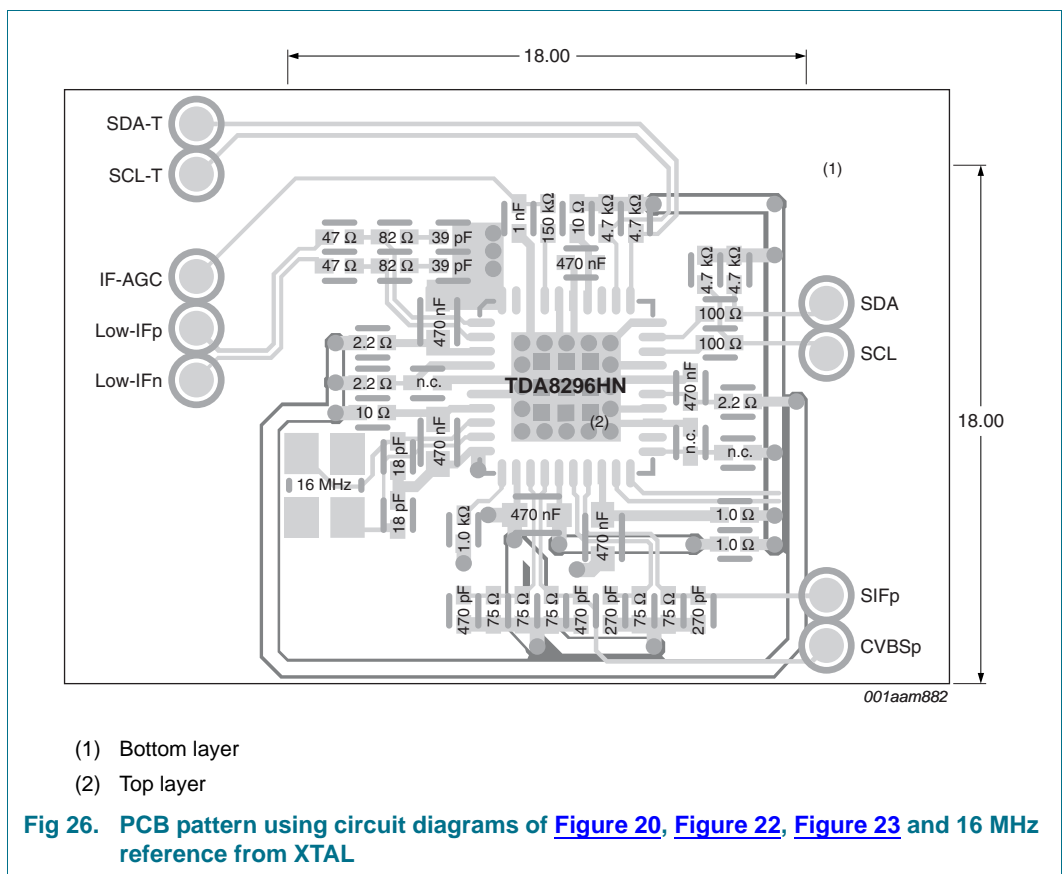

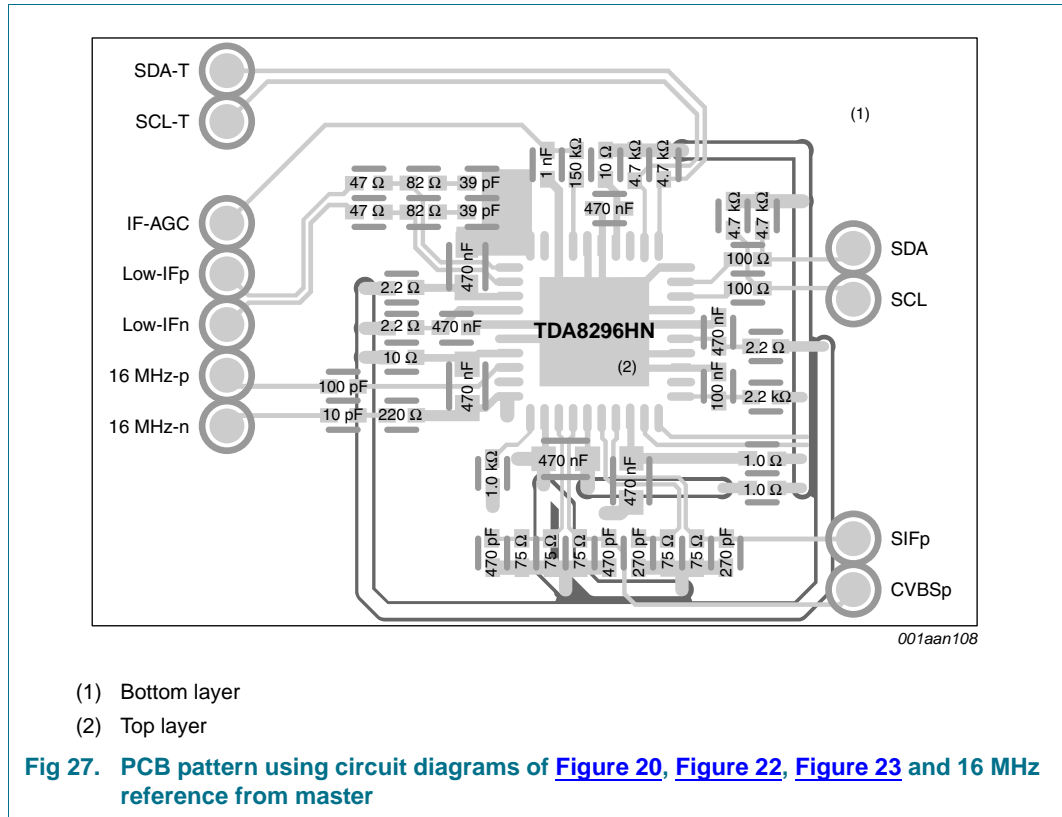

13.3 DAC connection

The video and sound output signals are converted from IC internal digital domain to analog output signal domain by digital controlled current sources. therefore the Digital to Analog Conversion (DAC) is based on controlled current sources. the current sources of the video and sound DACs are operating in differential mode. Even though differential mode can be used, the typical application use case is single ended. Each output of the differential pair needs to be terminated by the same impedance to ground. The termination impedance converts the DAC output current to signal voltage. The full scale DAC current is defined by application resistor R_{RSET} (connected between pin RSET and ground). Typical values of R_{RSET} are 1 k Ω and 2 k Ω . Additionally the full scale DAC current can be adjusted between 50% and 100% via register 0x35h (bits B_DA_V[5:0]) and via register 0x36h (bits B_DA_S[5:0]).

The full scale current is application dependent and needs to be matched to the termination (output voltage is product of DAC current and termination impedance value). The nominal peak-peak signal voltage should not exceed 1V_{pp}. The sum of AC and DC signal should not exceed 1.5V single ended.

The following relation gives the value of the full-scale current I_{FS} in function of the bias resistance value and value of B_DA_V[5:0] (part of register 0x35h) and value of B_DA_S[5:0] (part of register 0x36h) (B_DA_V or B_DA_S):

$$I_{FS} = \frac{1.216 V_{RSET}}{R_{RSET}} \times \frac{1}{5} \times \frac{64 + B_DA_V/S}{48} \times 64 \tag{2}$$

$$0 \leq B_DA_V/S \leq 63$$

For programming of B_DA_V see [Table 50](#), for B_DA_S see [Table 51](#).

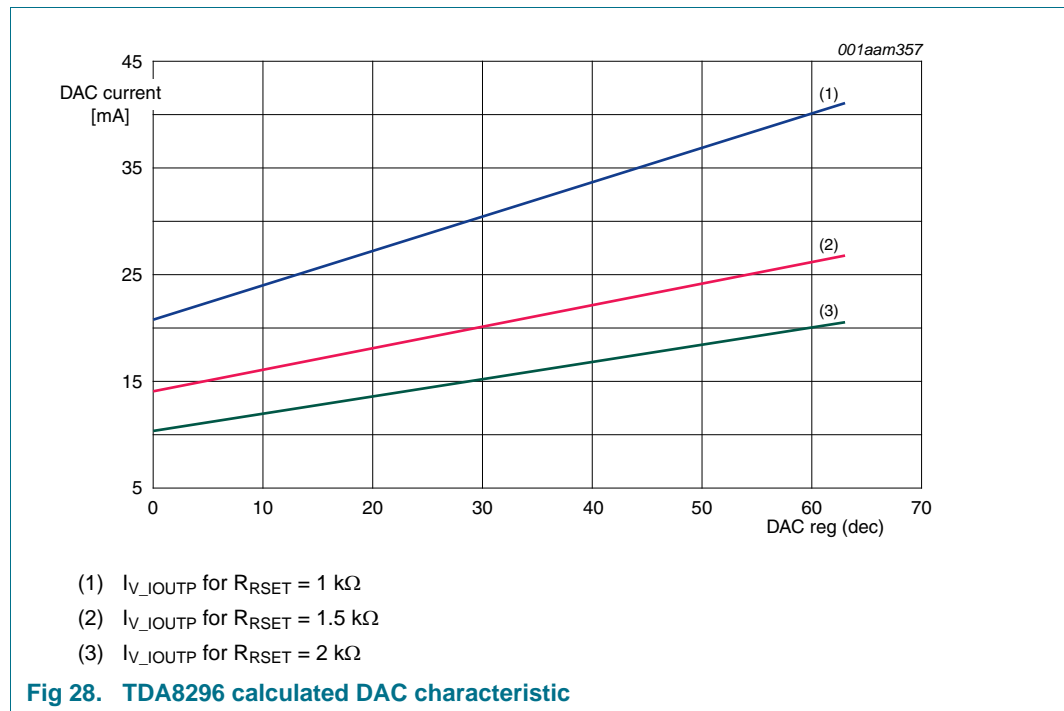

The DAC signal range used for CVBS and sound signal is reduced to provide headroom. The signal headroom is shown in [Figure 29](#) and [Figure 30](#). The full scale DAC current corresponds to digital input value of 1034. For the pins VIOUT_P and SIOUT_P the corresponding signal shapes of CVBS and sound signal can be mapped linear to the full scale DAC current. For the CVBS signal the sync level is fixed, the white level depends also on register value CVBS_LVL[7:0]. For the sound signal the DC level is fixed.

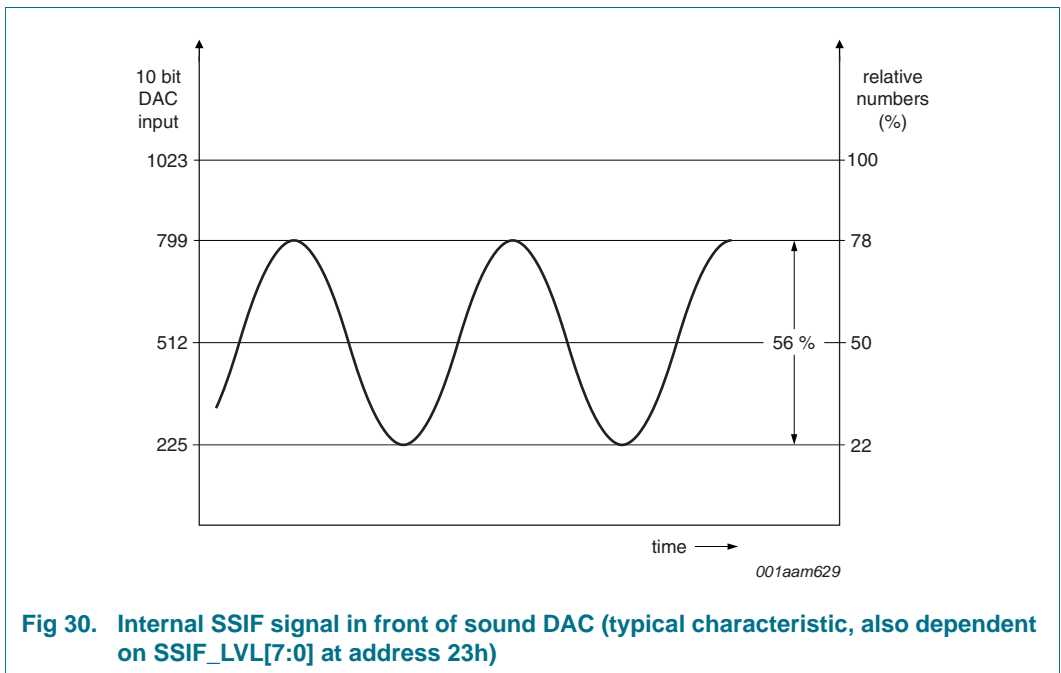
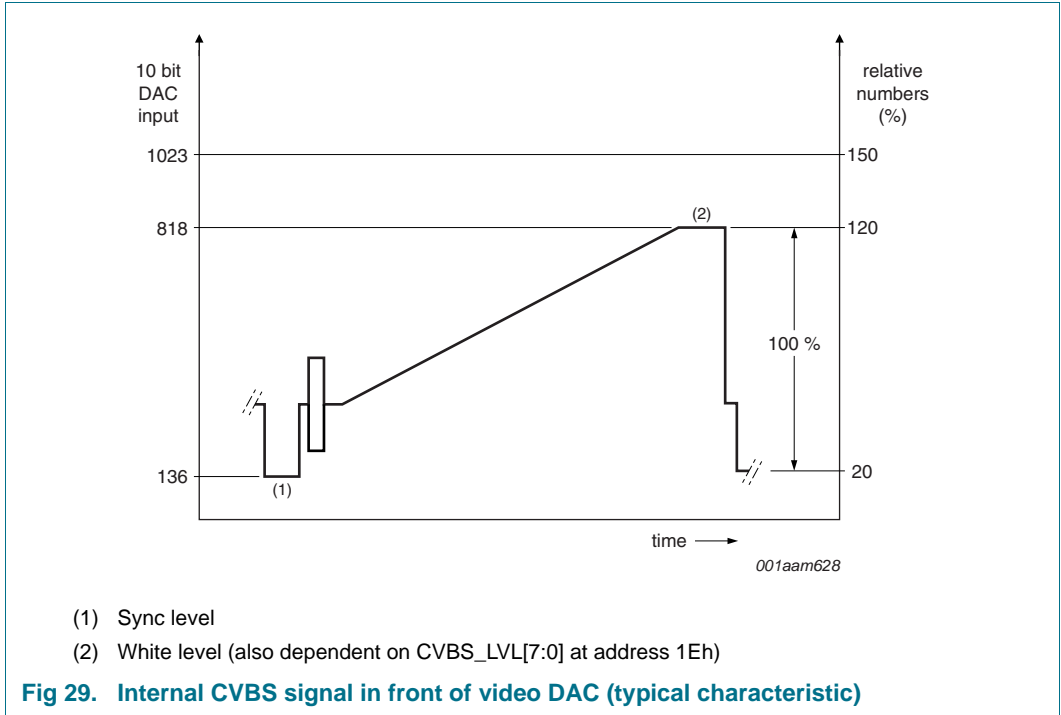

Application hints for DAC supply: it is required to use de-coupling capacitors at $V_{DDA(DAC1)(3V3)}$ and $V_{DDA(DAC2)(3V3)}$ supplies of > 100nF. A decoupling capacitor at pin RSET is not allowed. The component R_{RSET} should be placed close to the chip.

13.4 ADC connection

The input signals of the ADC (IF_POS and IF_NEG) can be either AC coupled by means of two capacitors or connected directly to the inputs (DC coupled). In case of AC coupling, the DCIN bit (see [Table 48](#)) should be set to logic 0, which enables the internal resistive dividers between $V_{DDA(ADC)(1V2)}$ and V_{SSD1} to take care of the correct DC biasing of the input signals.

In case the input signal is DC coupled, the input resistor network can be switched off by setting the DCIN bit to logic 1. When using the ADC in this mode, the Common mode level of the input signal should be at $(0.5 / 1.2) \times V_{DDA(ADC)(1V2)} \pm 200$ mV.

Please note that during power-down the DC biasing network at the input will be switched off in order to reduce current consumption. During Sleep mode however the resistor network will remain active.

13.5 Reset operation

13.5.1 Hardware reset

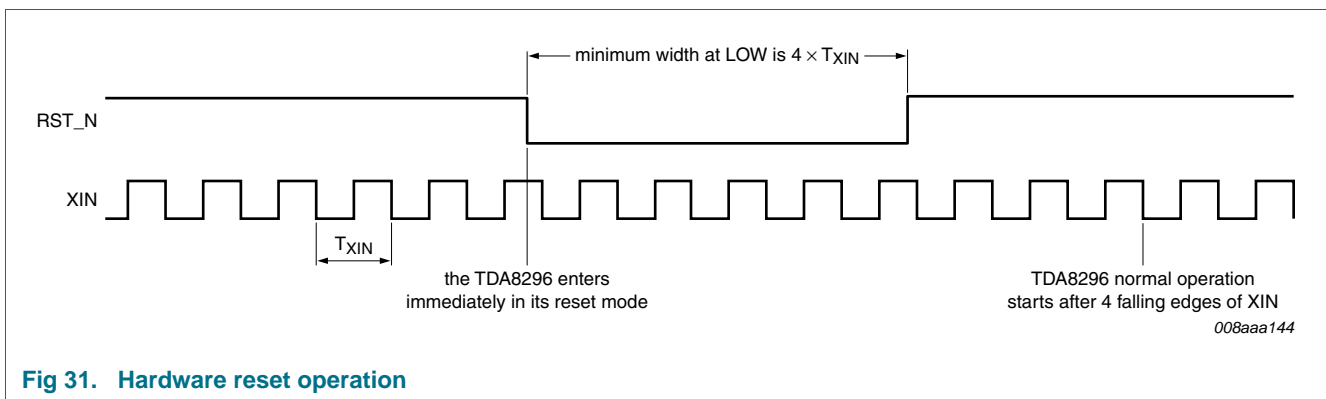

Fig 31. Hardware reset operation

After a hardware reset, the registers are set to default (power-on reset values) according to [Table 9](#). M/N standard is the default standard.

13.5.2 Software reset

A software reset can be done each time something has been programmed. The software reset does not affect the content of the registers but clears the flip-flops in the design. For the activation of the software reset see [Table 47](#) bit CLB.

13.6 Application hints

The DAC application can be adapted to a wide range of application needs. The data sheet describes 3 different use cases as shown in [Figure 23](#) to [Figure 25](#).

The default application (also used for specification) is shown in [Figure 23](#). This application supports 75 Ω DC termination for the video CVBS and > 1 kΩ AC/DC termination for the SSIF or mono audio sound signal. This application is e.g. preferred for device evaluation.

In applications, where the impedance of the CVBS termination is high (e.g. >1 kΩ), which is normally the case with audio/video processor, the video and sound DAC can operate with significant lower current. An application proposal (which leads to reduced power consumption) is shown in [Figure 24](#).

For application requirements, where both, connections to audio/video processor (with input impedance >1 kΩ) and 75 Ω termination (e.g. to SCART output), are needed in parallel, a buffer application can be used as shown in [Figure 25](#).

13.7 Crystal connection

The typical crystal frequency value is 16 MHz. The values of the passive components depend on crystal manufacturer. The oscillator can be set in two configurations depending on the origin of the crystal. [Figure 32](#) describes the case of an crystal shared with the tuner and the TDA8296 (Slave mode), [Figure 33](#) the case of an crystal dedicated to the TDA8296 (Oscillator mode).

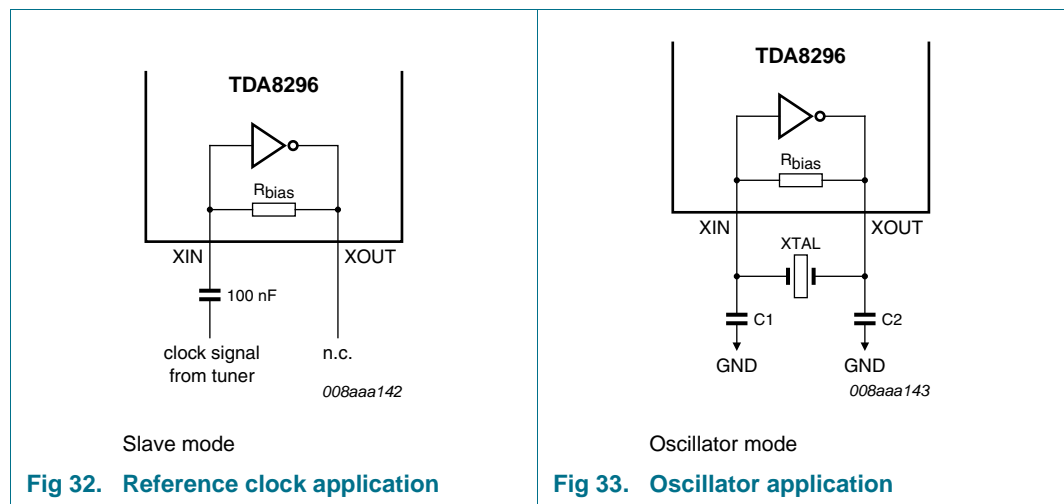

Fig 32. Reference clock application

Fig 33. Oscillator application

In Oscillator mode, only a crystal and the load capacitances C1 and C2 need to be connected externally since the feedback resistance is integrated on chip. For an accurate time reference it is advised to use the load capacitors as specified in [Table 65](#). C_L is the typical load capacitance of the crystal and is usually specified by the crystal manufacturer.

Table 65. Crystal parameters together with external components

Fundamental oscillation frequency	Crystal load capacitance C _{L(xtal)} (pF)	Crystal series resistance R _{S(xtal)} (Ω)	External load capacitors	
			C1 (pF)	C2 (pF)
1 MHz to 5 MHz	10	< 300	18	18
	20	< 300	39	39
	30	< 300	56	56
5 MHz to 10 MHz	10	< 300	18	18
	20	< 200	39	39
	30	< 100	56	56

Table 65. Crystal parameters together with external components ...continued

Fundamental oscillation frequency	Crystal load capacitance $C_{L(xtal)}$ (pF)	Crystal series resistance $R_{s(xtal)}$ (Ω)	External load capacitors	
			C1 (pF)	C2 (pF)
10 MHz to 15 MHz	10	< 160	18	18
	20	< 60	39	39
15 MHz to 20 MHz	10	< 80	18	18

13.8 Alternative ADC sampling rates

In combination with a tuner front-end an alternative ADC sampling rates could be necessary. Please refer to [Table 66](#)

The default register setting is adapted to 16 MHz reference frequency (either from crystal or external source) and a nominal $f_{ADC} = 54$ MHz. In case of crosstalk of clock related signals (e.g. $n \times 54$ MHz) into the RF input of connected tuner circuit, the potential disturbance of the wanted TV channel can be avoided by switching to the alternative ADC clock frequencies of 50.75 MHz or 57.25 MHz.

Table 66. Alternative ADC clocks

Frequencies				
ADC SR	50.75 MHz	54.00 MHz	57.25 MHz	
Clock PLL	101.50 MHz	108.00 MHz	114.50 MHz	
Xtal frequency	16.00 MHz	16.00 MHz	16.00 MHz	
Divider				
M	203	27	229	
N	16	2	16	
P	2	2	2	
Registers				
Register 2Bh	01h	01h	02h	
Register 38h	23h	23h	23h	
Register 3Eh	63h	63h	63h	
Register 3Fh	01h	01h	01h	
Register 40h	CAh	1Ah	E4h	
Register 41h	1Eh	02h	1Eh	
Register 41h	61h	61h	61h	

14. Test information

14.1 Boundary scan interface (“IEEE Std. 1149.1”)

The TDA8296 implements a boundary scan architecture to allow access to, and control of, board test support features within integrated circuits through a TAP. The TAP controller is a synchronous state machine that controls the sequence of operations on the TAP circuitry when the TMS signal changes. All state transitions occur on the basis of the TMS value on the rising edge of TCK. The instruction register is a shift register based design. It decodes the test to be performed and/or the test data register to be accessed. The instructions are shifted into the register through the TDI and are latched as the current instruction at the completion of the shifting process. The TDA8296 boundary scan architecture includes: a TAP controller, a scannable instruction register and three scannable test data registers: a boundary scan register, a device ID register, and a bypass register.

The supported instructions are: EXTEST, IDCODE, SAMPLE, INTEST, CLAMP, HIGHZ and BYPASS.

The boundary scan register is composed of 16 cells (see [Table 67](#)). Each cell is associated either to an input pad, an output pad, a bidirectional pad or to the bidirectional or 3-state command itself. All cells are of ‘observe and control’ type.

The device ID register is a 32-bit identification register that is included in the scan register itself and contains the ID number. It is a fixed value that identifies the chip.

ID number structure is:

ID version [3:0] = 1h
ID part number [15:0] = 224Ch
ID manufacturer [11:1] = 015h
ID mandatory [0] = 1h
IDCODE [31:0] = 1224 C02Bh

When the boundary scan function is not used, please connect the four dedicated input pins (TRST_N, TCK, TDI and TMS) to GND.

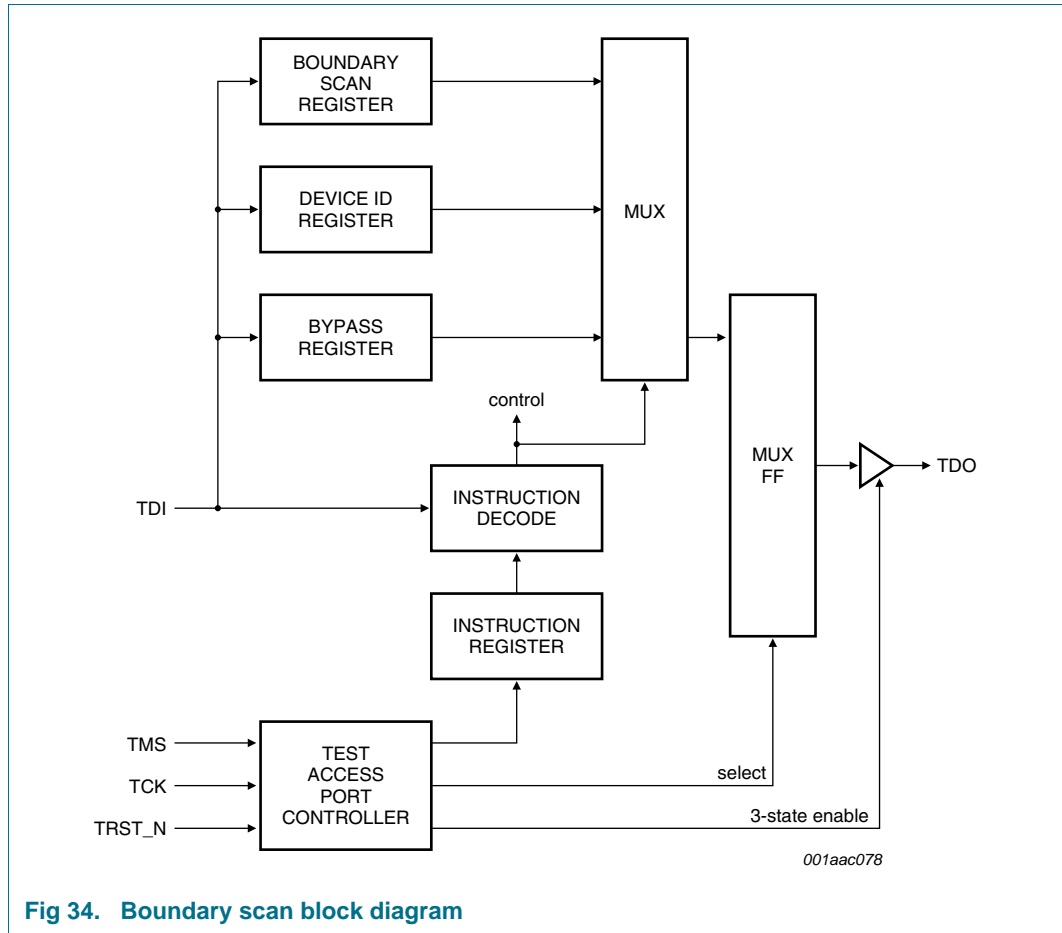

Fig 34. Boundary scan block diagram

Table 67. Boundary scan register list

Pad signal	Chain position	Pad type	Scan type	Control signal
IF_AGC	[1]	Bidir	control/observe	U1.vagc_cmd
	[2]	Ctrl	control/observe	U1.vagc_cmd
GPIO0	[3]	Bidir	control/observe	U1.gpio0_cmd
	[4]	Ctrl	control/observe	U1.gpio0_cmd
GPIO1	[5]	Bidir	control/observe	U1.gpio1_cmd
	[6]	Ctrl	control/observe	U1.gpio1_cmd
GPIO2	[7]	Bidir	control/observe	U1.gpio2_cmd
	[8]	Ctrl	control/observe	U1.gpio2_cmd
SDA	[9]	Bidir	control/observe	U1.sda_cmd
	[10]	Ctrl	control/observe	U1.sda_cmd
SCL	[11]	input	control/observe	-
RST_N	[12]	input	control/observe	-
SADDR1	[13]	Ctrl	control/observe	U1.saddr1_cmd
	[14]	Bidir	control/observe	U1.saddr1_cmd
SADDR0	[15]	Ctrl	control/observe	U0.saddr1_cmd
	[16]	Bidir	control/observe	U0.saddr1_cmd

Table 68. Boundary scan electrical characteristics

Symbol	Parameter	Conditions	Min	Typ	Max	Unit
T_{cy}	cycle time	TCK	25	-	-	ns
t_{su}	set-up time	TDI and TMS	0	-	-	ns
t_h	hold time	TDI and TMS	4	-	-	ns
$t_{d(TDO)}$	delay time on pin TDO	on 50 pF	-	-	12	ns

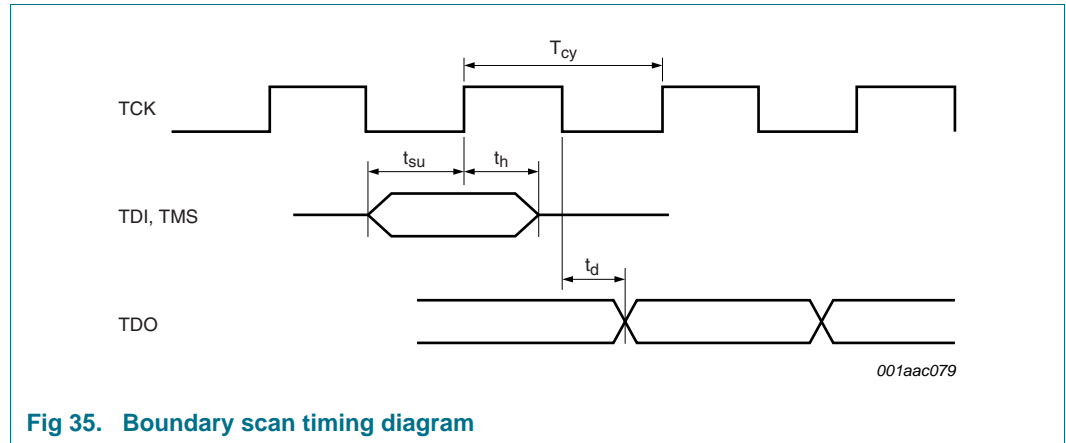
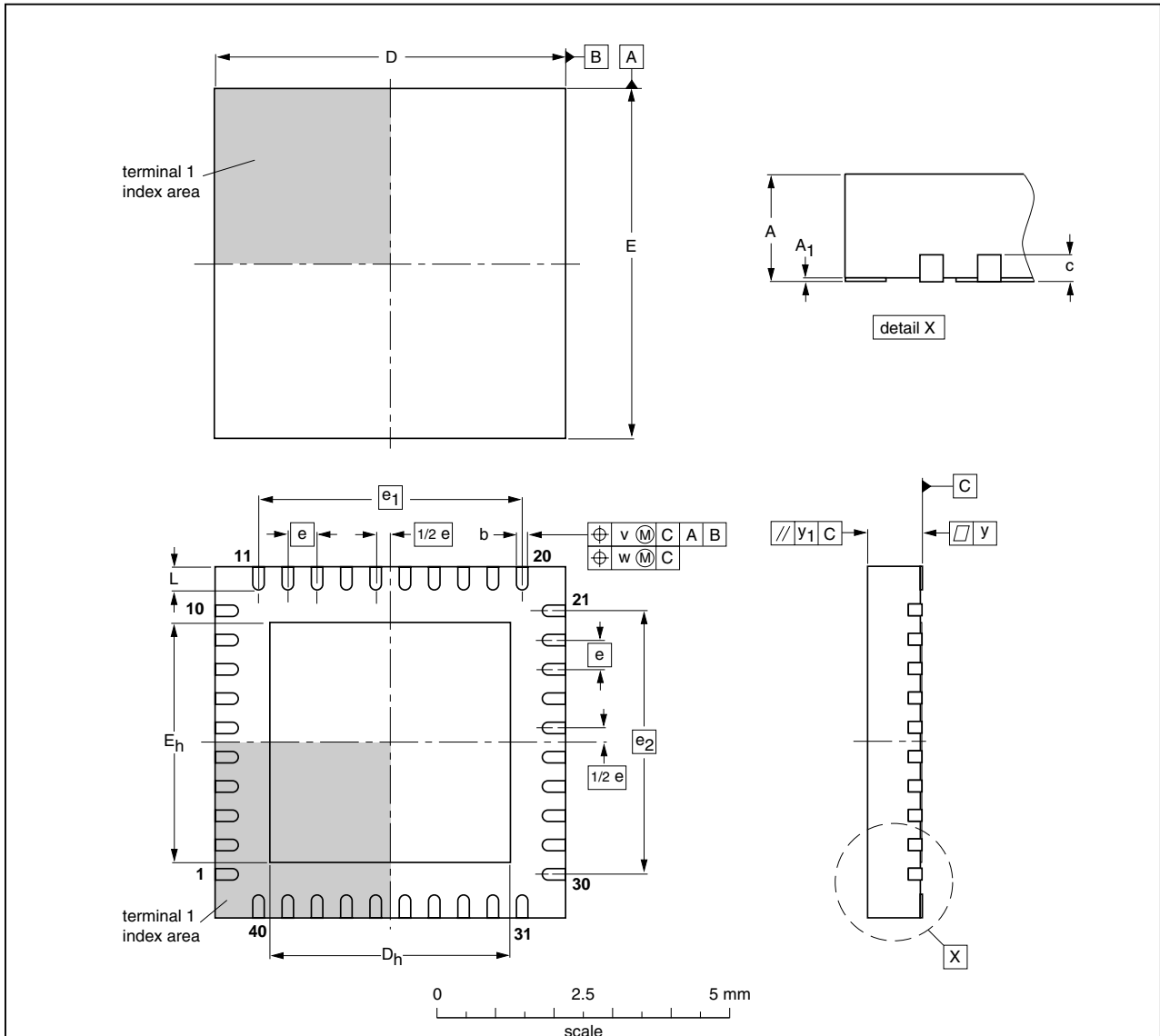

Fig 35. Boundary scan timing diagram

15. Package outline

HVQFN40: plastic thermal enhanced very thin quad flat package; no leads; 40 terminals; body 6 x 6 x 0.85 mm

SOT618-1



DIMENSIONS (mm are the original dimensions)

UNIT	A ⁽¹⁾ max.	A ₁	b	c	D ⁽¹⁾	D _h	E ⁽¹⁾	E _h	e	e ₁	e ₂	L	v	w	y	y ₁
mm	1	0.05 0.00	0.30 0.18	0.2	6.1 5.9	4.25 3.95	6.1 5.9	4.25 3.95	0.5	4.5	4.5	0.5 0.3	0.1	0.05	0.05	0.1

Note

1. Plastic or metal protrusions of 0.075 mm maximum per side are not included.

OUTLINE VERSION	REFERENCES				EUROPEAN PROJECTION	ISSUE DATE
	IEC	JEDEC	JEITA			
SOT618-1	---	MO-220	---			01-08-08 02-10-22

Fig 36. Package outline SOT618-1 (HVQFN40)

16. Soldering of SMD packages

This text provides a very brief insight into a complex technology. A more in-depth account of soldering ICs can be found in Application Note *AN10365 "Surface mount reflow soldering description"*.

16.1 Introduction to soldering

Soldering is one of the most common methods through which packages are attached to Printed Circuit Boards (PCBs), to form electrical circuits. The soldered joint provides both the mechanical and the electrical connection. There is no single soldering method that is ideal for all IC packages. Wave soldering is often preferred when through-hole and Surface Mount Devices (SMDs) are mixed on one printed wiring board; however, it is not suitable for fine pitch SMDs. Reflow soldering is ideal for the small pitches and high densities that come with increased miniaturization.

16.2 Wave and reflow soldering

Wave soldering is a joining technology in which the joints are made by solder coming from a standing wave of liquid solder. The wave soldering process is suitable for the following:

- Through-hole components
- Leaded or leadless SMDs, which are glued to the surface of the printed circuit board

Not all SMDs can be wave soldered. Packages with solder balls, and some leadless packages which have solder lands underneath the body, cannot be wave soldered. Also, leaded SMDs with leads having a pitch smaller than ~0.6 mm cannot be wave soldered, due to an increased probability of bridging.

The reflow soldering process involves applying solder paste to a board, followed by component placement and exposure to a temperature profile. Leaded packages, packages with solder balls, and leadless packages are all reflow solderable.

Key characteristics in both wave and reflow soldering are:

- Board specifications, including the board finish, solder masks and vias
- Package footprints, including solder thieves and orientation
- The moisture sensitivity level of the packages
- Package placement
- Inspection and repair
- Lead-free soldering versus SnPb soldering

16.3 Wave soldering

Key characteristics in wave soldering are:

- Process issues, such as application of adhesive and flux, clinching of leads, board transport, the solder wave parameters, and the time during which components are exposed to the wave
- Solder bath specifications, including temperature and impurities

16.4 Reflow soldering

Key characteristics in reflow soldering are:

- Lead-free versus SnPb soldering; note that a lead-free reflow process usually leads to higher minimum peak temperatures (see [Figure 37](#)) than a SnPb process, thus reducing the process window
- Solder paste printing issues including smearing, release, and adjusting the process window for a mix of large and small components on one board
- Reflow temperature profile; this profile includes preheat, reflow (in which the board is heated to the peak temperature) and cooling down. It is imperative that the peak temperature is high enough for the solder to make reliable solder joints (a solder paste characteristic). In addition, the peak temperature must be low enough that the packages and/or boards are not damaged. The peak temperature of the package depends on package thickness and volume and is classified in accordance with [Table 69](#) and [70](#)

Table 69. SnPb eutectic process (from J-STD-020C)

Package thickness (mm)	Package reflow temperature (°C)	
	Volume (mm ³)	
	< 350	≥ 350
< 2.5	235	220
≥ 2.5	220	220

Table 70. Lead-free process (from J-STD-020C)

Package thickness (mm)	Package reflow temperature (°C)		
	Volume (mm ³)		
	< 350	350 to 2000	> 2000
< 1.6	260	260	260
1.6 to 2.5	260	250	245
> 2.5	250	245	245

Moisture sensitivity precautions, as indicated on the packing, must be respected at all times.

Studies have shown that small packages reach higher temperatures during reflow soldering, see [Figure 37](#).

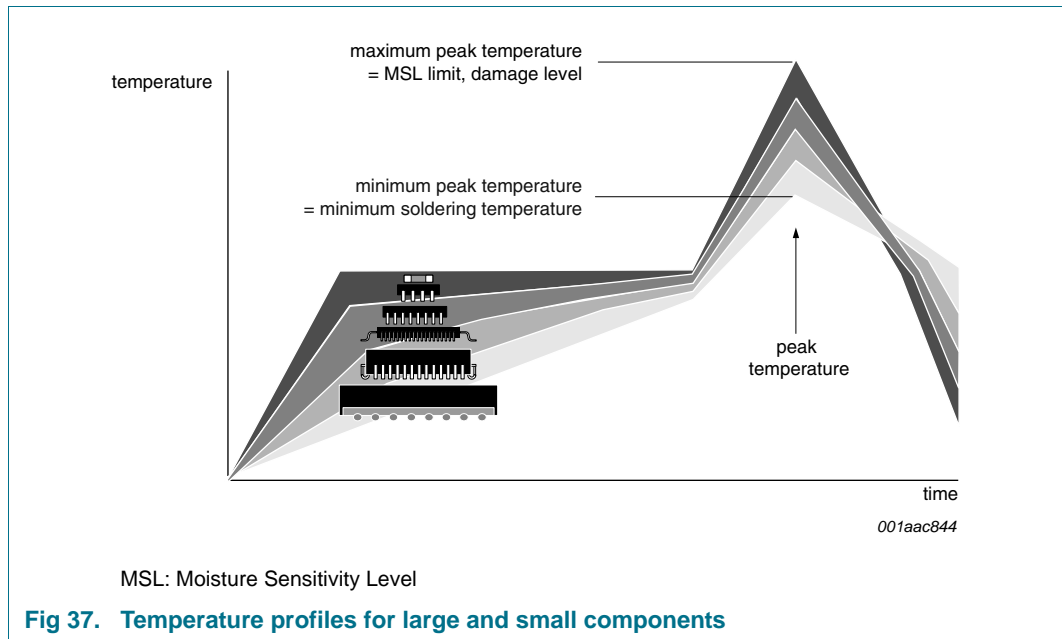

For further information on temperature profiles, refer to Application Note AN10365 “Surface mount reflow soldering description”.

17. Abbreviations

Table 71. Abbreviations

Acronym	Description
ADC	Analog-to-Digital Converter
AFC	Automatic Frequency Control
AGC	Automatic Gain Control
CC	Color Carrier
CMOS	Complementary Metal-Oxide Semiconductor
CORDIC	COordinate Rotation Digital Computer
CVBS	Color Video Blanking Signal
DAC	Digital-to-Analog Converter
DTO	Digitally Tuned Oscillator
DVD	Digital Versatile Disc
FIR	Finite Impulse Response
FPLL	Frequency Phase-Locked Loop
FS	Full Scale
GPIO	General Purpose Input Output
H/V	Horizontal and Vertical
HAD	Half Amplitude Duration
IC	Integrated Circuit
ID	IDentification
IF	Intermediate Frequency

Table 71. Abbreviations ...continued

Acronym	Description
NPC	Neighbor Picture Carrier
NSC	Neighbor Sound Carrier
PC	Picture Carrier
PCB	Printed-Circuit Board
PLL	Phase-Locked Loop
POR	Power-On Reset
PWM	Pulse Width Modulation
QSS	Quasi Split Sound
SAW	Surface Acoustic Wave
SC	Sound Carrier
SCART	Syndicat des Constructeurs d'Appareils Radiorécepteurs et Téléviseurs Radio and Television Receiver Manufacturers' Association
SMD	Surface Mounted Device
SSIF	Second Sound Intermediate Frequency
TAP	Test Access Port
VITS	Vertical Interval Test Signal

18. Revision history

Table 72. Revision history

Document ID	Release date	Data sheet status	Change notice	Supersedes
TDA8296 v.1	20110303	Product data sheet	-	-

19. Legal information

19.1 Data sheet status

Document status ^{[1][2]}	Product status ^[3]	Definition
Objective [short] data sheet	Development	This document contains data from the objective specification for product development.
Preliminary [short] data sheet	Qualification	This document contains data from the preliminary specification.
Product [short] data sheet	Production	This document contains the product specification.

[1] Please consult the most recently issued document before initiating or completing a design.

[2] The term 'short data sheet' is explained in section "Definitions".

[3] The product status of device(s) described in this document may have changed since this document was published and may differ in case of multiple devices. The latest product status information is available on the Internet at URL <http://www.nxp.com>.

19.2 Definitions

Draft — The document is a draft version only. The content is still under internal review and subject to formal approval, which may result in modifications or additions. NXP Semiconductors does not give any representations or warranties as to the accuracy or completeness of information included herein and shall have no liability for the consequences of use of such information.

Short data sheet — A short data sheet is an extract from a full data sheet with the same product type number(s) and title. A short data sheet is intended for quick reference only and should not be relied upon to contain detailed and full information. For detailed and full information see the relevant full data sheet, which is available on request via the local NXP Semiconductors sales office. In case of any inconsistency or conflict with the short data sheet, the full data sheet shall prevail.

Product specification — The information and data provided in a Product data sheet shall define the specification of the product as agreed between NXP Semiconductors and its customer, unless NXP Semiconductors and customer have explicitly agreed otherwise in writing. In no event however, shall an agreement be valid in which the NXP Semiconductors product is deemed to offer functions and qualities beyond those described in the Product data sheet.

19.3 Disclaimers

Limited warranty and liability — Information in this document is believed to be accurate and reliable. However, NXP Semiconductors does not give any representations or warranties, expressed or implied, as to the accuracy or completeness of such information and shall have no liability for the consequences of use of such information.

In no event shall NXP Semiconductors be liable for any indirect, incidental, punitive, special or consequential damages (including - without limitation - lost profits, lost savings, business interruption, costs related to the removal or replacement of any products or rework charges) whether or not such damages are based on tort (including negligence), warranty, breach of contract or any other legal theory.

Notwithstanding any damages that customer might incur for any reason whatsoever, NXP Semiconductors' aggregate and cumulative liability towards customer for the products described herein shall be limited in accordance with the *Terms and conditions of commercial sale* of NXP Semiconductors.

Right to make changes — NXP Semiconductors reserves the right to make changes to information published in this document, including without limitation specifications and product descriptions, at any time and without notice. This document supersedes and replaces all information supplied prior to the publication hereof.

Suitability for use — NXP Semiconductors products are not designed, authorized or warranted to be suitable for use in life support, life-critical or safety-critical systems or equipment, nor in applications where failure or

malfunction of an NXP Semiconductors product can reasonably be expected to result in personal injury, death or severe property or environmental damage. NXP Semiconductors accepts no liability for inclusion and/or use of NXP Semiconductors products in such equipment or applications and therefore such inclusion and/or use is at the customer's own risk.

Applications — Applications that are described herein for any of these products are for illustrative purposes only. NXP Semiconductors makes no representation or warranty that such applications will be suitable for the specified use without further testing or modification.

Customers are responsible for the design and operation of their applications and products using NXP Semiconductors products, and NXP Semiconductors accepts no liability for any assistance with applications or customer product design. It is customer's sole responsibility to determine whether the NXP Semiconductors product is suitable and fit for the customer's applications and products planned, as well as for the planned application and use of customer's third party customer(s). Customers should provide appropriate design and operating safeguards to minimize the risks associated with their applications and products.

NXP Semiconductors does not accept any liability related to any default, damage, costs or problem which is based on any weakness or default in the customer's applications or products, or the application or use by customer's third party customer(s). Customer is responsible for doing all necessary testing for the customer's applications and products using NXP Semiconductors products in order to avoid a default of the applications and the products or of the application or use by customer's third party customer(s). NXP does not accept any liability in this respect.

Limiting values — Stress above one or more limiting values (as defined in the Absolute Maximum Ratings System of IEC 60134) will cause permanent damage to the device. Limiting values are stress ratings only and (proper) operation of the device at these or any other conditions above those given in the Recommended operating conditions section (if present) or the Characteristics sections of this document is not warranted. Constant or repeated exposure to limiting values will permanently and irreversibly affect the quality and reliability of the device.

Terms and conditions of commercial sale — NXP Semiconductors products are sold subject to the general terms and conditions of commercial sale, as published at <http://www.nxp.com/profile/terms>, unless otherwise agreed in a valid written individual agreement. In case an individual agreement is concluded only the terms and conditions of the respective agreement shall apply. NXP Semiconductors hereby expressly objects to applying the customer's general terms and conditions with regard to the purchase of NXP Semiconductors products by customer.

No offer to sell or license — Nothing in this document may be interpreted or construed as an offer to sell products that is open for acceptance or the grant, conveyance or implication of any license under any copyrights, patents or other industrial or intellectual property rights.

Export control — This document as well as the item(s) described herein may be subject to export control regulations. Export might require a prior authorization from national authorities.

Quick reference data — The Quick reference data is an extract of the product data given in the Limiting values and Characteristics sections of this document, and as such is not complete, exhaustive or legally binding.

Non-automotive qualified products — Unless this data sheet expressly states that this specific NXP Semiconductors product is automotive qualified, the product is not suitable for automotive use. It is neither qualified nor tested in accordance with automotive testing or application requirements. NXP Semiconductors accepts no liability for inclusion and/or use of non-automotive qualified products in automotive equipment or applications.

In the event that customer uses the product for design-in and use in automotive applications to automotive specifications and standards, customer (a) shall use the product without NXP Semiconductors' warranty of the product for such automotive applications, use and specifications, and (b) whenever customer uses the product for automotive applications beyond

NXP Semiconductors' specifications such use shall be solely at customer's own risk, and (c) customer fully indemnifies NXP Semiconductors for any liability, damages or failed product claims resulting from customer design and use of the product for automotive applications beyond NXP Semiconductors' standard warranty and NXP Semiconductors' product specifications.

19.4 Trademarks

Notice: All referenced brands, product names, service names and trademarks are the property of their respective owners.

I²C-bus — logo is a trademark of NXP B.V.

Silicon Tuner — is a trademark of NXP B.V.

20. Contact information

For more information, please visit: <http://www.nxp.com>

For sales office addresses, please send an email to: salesaddresses@nxp.com

21. Tables

Table 1. Quick reference data	3	bit description	34
Table 2. Ordering information	5	Table 30. CVBS_SET register (address 1Dh)	34
Table 3. Pin allocation table	7	bit description	34
Table 4. Pin description	8	Table 31. CVBS_LEVEL register (address 1Eh)	35
Table 5. Pin type description	10	bit description	35
Table 6. Address format	13	Table 32. CVBS_EQ register (address 1Fh)	35
Table 7. I ² C-bus transfer description	13	bit description	35
Table 8. I ² C-bus transfer description	14	Table 33. SSIF_MUTE register (address 05h)	36
Table 9. I ² C-bus register reference	15	bit description	36
Table 10. I ² C-bus registers	18	Table 34. SOUNDSET_1 register (address 20h)	36
Table 11. STANDARD register (address 00h)	23	bit description	36
bit description	23	Table 35. SOUNDSET_2 register (address 21h)	37
Table 12. EASY_PROG register (address 01h)	23	bit description	37
bit description	23	Table 36. SOUND_LEVEL register (address 22h)	38
Table 13. Easy programming values	24	bit description	38
Table 14. DIV_FUNC register (address 02h)	25	Table 37. SSIF_LEVEL register (address 23h)	39
bit description	25	bit description	39
Table 15. ADC_HEADR register (address 03h)	25	Table 38. ADC_SAT register (address 24h)	40
bit description	25	bit description	40
Table 16. PC_PLL_FUNC register (address 04h)	26	Table 39. AFC register (address 25h) bit description	41
bit description	26	Table 40. Calculation of frequency deviation from AFC	41
Table 17. DTO_PC_LOW, DTO_PC_MID and	26	value	41
DTO_PC_HIGH register	26	Table 41. HVPLL_STAT register (address 26h)	42
(address 09h to 0Bh) bit description	26	bit description	42
Table 18. Values of DTO_PC per TV standard	27	Table 42. D_IF_AGC_STAT register (address 27h)	43
at 54 MHz sampling frequency	27	bit description	43
Table 19. DTO_SC_LOW, DTO_SC_MID and	27	Table 43. T_IF_AGC_STAT register (address 28h)	43
DTO_SC_HIGH register (address 0Ch to 0Eh)	27	bit description	43
bit description	27	Table 44. ALT_FILT_COEF register (address 2Bh)	43
Table 20. Values for SSIF mode at 54 MHz sampling	28	bit description	43
frequency	28	Table 45. SSIF_AGC_STAT register (address 2Dh)	43
Table 21. FILTERS_1 register (address 0Fh)	28	bit description	43
bit description	28	Table 46. IDENTITY register (address 2Fh)	43
Table 22. FILTERS_2 register (address 10h)	30	bit description	43
bit description	30	Table 47. CLB_STDBY register (address 30h)	43
Table 23. GRP_DELAY register (address 11h)	31	bit description	43
bit description	31	Table 48. ADC_CTL register (address 33h)	44
Table 24. D_IF_AGC_SET_1 register (address 12h)	32	bit description	44
bit description	32	Table 49. ADC_CTL_2 register (address 34h)	44
Table 25. D_IF_AGC_SET_2 register (address 13h)	32	bit description	44
bit description	32	Table 50. VIDEODAC_CTL register (address 35h)	45
Table 26. T_IF_AGC_SET register (address 15h)	32	bit description	45
bit description	32	Table 51. AUDIODAC_CTL register (address 36h)	46
Table 27. T_IF_AGC_LIM register (address 16h)	33	bit description	46
bit description	33	Table 52. DAC_REF_CLK_CTL register	46
Table 28. T_IF_AGC_FORCE register (address 17h)	33	(address 37h) bit description	46
bit description	33	Table 53. PLL_REG07, PLL_REG08, PLL_REG09	46
Table 29. V_SYNC_DEL register (address 1Ch)	33	and PLL_REG10 register (address 3Fh to 42h)	46

continued >>

bit description46

Table 54. GPIOREG_0 register (address 44h)
bit description47

Table 55. GPIOREG_1 register (address 45h)
bit description47

Table 56. HVPLL signal configuration48

Table 57. GPIOREG_2 register (address 46h)
bit description48

Table 58. GD_EQ_SECTx_C1 and GD_EQ_SECTx_C2
(x = 1 to 4) register (address 4Bh to 52h)
bit description49

Table 59. Coefficients used in group delay equalizer
example50

Table 60. CVBS_EQ_COEFx_LOW and
CVBS_EQ_COEFx_HIGH (x = 0 to 5) register
(address 57h to 62h) bit description50

Table 61. Coefficients used in video equalizer
example52

Table 62. Limiting values53

Table 63. Thermal characteristics53

Table 64. Characteristics54

Table 65. Crystal parameters together with external
components72

Table 66. Alternative ADC clocks73

Table 67. Boundary scan register list75

Table 68. Boundary scan electrical characteristics76

Table 69. SnPb eutectic process (from J-STD-020C) ...79

Table 70. Lead-free process (from J-STD-020C)79

Table 71. Abbreviations80

Table 72. Revision history81

22. Figures

Fig 1.	Functional diagram of TDA8296	6
Fig 2.	Pin configuration for HVQFN40	7
Fig 3.	I ² C-bus Write mode	13
Fig 4.	Examples I ² C-bus Write mode	13
Fig 5.	I ² C-bus Read mode	14
Fig 6.	Example I ² C-bus Read mode	14
Fig 7.	TDA8296 DTO_PC characteristic	27
Fig 8.	TDA8296 DTO_SC characteristic	28
Fig 9.	Video low-pass filters for sound carrier suppression	29
Fig 10.	Notch filter for adjacent sound carrier suppression	29
Fig 11.	Video low pass frequency response in smooth roll off or low ripple mode	30
Fig 12.	SSIF and FM radio band-pass filters (center frequency 5.5 MHz chosen)	31
Fig 13.	Video equalizer curves	36
Fig 14.	TDA8296 SSIF characteristic versus C _S (refer to Figure 23) typical values; termination 75 Ω and 1 kΩ in parallel	40
Fig 15.	TDA8296 AFC characteristic	42
Fig 16.	Internal low IF frequency response in front of the VIF demodulator	45
Fig 17.	Example for the programmable group delay equalizer	50
Fig 18.	Example for the programmable video equalizer	52
Fig 19.	Typical application of TDA8296	64
Fig 20.	IF input application for interlacing TDA1827x	64
Fig 21.	IF input application	64
Fig 22.	Main application diagram	65
Fig 23.	75 Ω load	66
Fig 24.	High ohmic load	66
Fig 25.	Buffer application with 75 Ω load	67
Fig 26.	PCB pattern using circuit diagrams of Figure 20 , Figure 22 , Figure 23 and 16 MHz reference from XTAL	67
Fig 27.	PCB pattern using circuit diagrams of Figure 20 , Figure 22 , Figure 23 and 16 MHz reference from master	68
Fig 28.	TDA8296 calculated DAC characteristic	69
Fig 29.	Internal CVBS signal in front of video DAC (typical characteristic)	70
Fig 30.	Internal SSIF signal in front of sound DAC (typical characteristic, also dependent on SSIF_LVL[7:0] at address 23h)	70
Fig 31.	Hardware reset operation	71
Fig 32.	Reference clock application	72
Fig 33.	Oscillator application	72
Fig 34.	Boundary scan block diagram	75
Fig 35.	Boundary scan timing diagram	76
Fig 36.	Package outline SOT618-1 (HVQFN40)	77
Fig 37.	Temperature profiles for large and small components	80

23. Contents

1	General description	1	9.3.19	Special equalizer functions for group delay and video (CVBS)	49
2	Features and benefits	1	10	Limiting values	53
3	Applications	2	11	Thermal characteristics	53
4	Quick reference data	3	12	Characteristics	54
5	Ordering information	5	13	Application information	64
6	Functional diagram	6	13.1	Typical application	64
7	Pinning information	7	13.1.1	IF input application	64
7.1	Pinning	7	13.2	Detailed application diagrams	65
7.2	Pin description	8	13.2.1	Main application diagram	65
8	Functional description	10	13.2.2	75 W application	66
8.1	IF ADC	10	13.2.3	100 W application	66
8.2	Filters	10	13.2.4	Buffer application	67
8.3	PLL demodulator	10	13.2.5	Layout recommendations	67
8.4	Nyquist filter, video low-pass filter, video and group delay equalizer, video leveling	10	13.3	DAC connection	68
8.5	Upsampler and video DAC	11	13.4	ADC connection	71
8.6	SSIF/mono sound processing	11	13.5	Reset operation	71
8.7	Tuner IF AGC	11	13.5.1	Hardware reset	71
8.8	Digital IF AGC	12	13.5.2	Software reset	71
8.9	Clock generation	12	13.6	Application hints	71
9	I²C-bus control	12	13.7	Crystal connection	72
9.1	Protocol of the I ² C-bus serial interface	12	13.8	Alternative ADC sampling rates	73
9.1.1	Write mode	13	14	Test information	74
9.1.2	Read mode	14	14.1	Boundary scan interface ("IEEE Std. 1149.1")	74
9.2	Register overview	15	15	Package outline	77
9.3	Register description	23	16	Soldering of SMD packages	78
9.3.1	Standard setting with easy programming	23	16.1	Introduction to soldering	78
9.3.2	Diverse functions (includes tuner IF AGC Pin mode)	25	16.2	Wave and reflow soldering	78
9.3.3	ADC headroom	25	16.3	Wave soldering	78
9.3.4	Picture carrier PLL functions	26	16.4	Reflow soldering	79
9.3.5	Picture and sound carrier DTO	26	17	Abbreviations	80
9.3.6	Filter settings	28	18	Revision history	81
9.3.7	Group delay equalization	31	19	Legal information	82
9.3.8	Digital IF AGC functions	32	19.1	Data sheet status	82
9.3.9	Tuner IF AGC functions	32	19.2	Definitions	82
9.3.10	V-sync adjustment	34	19.3	Disclaimers	82
9.3.11	CVBS settings	34	19.4	Trademarks	83
9.3.12	SSIF and mono sound settings	36	20	Contact information	83
9.3.13	Status registers: ADC saturation, AFC, H/V PLL and AGC	40	21	Tables	84
9.3.14	Chip identification and Standby mode	43	22	Figures	86
9.3.15	ADC control	44	23	Contents	87
9.3.16	Video and sound DAC control	45			
9.3.17	Clock generation (PLL and crystal oscillator)	46			
9.3.18	GPIOs	47			

Please be aware that important notices concerning this document and the product(s) described herein, have been included in section 'Legal information'.

© NXP B.V. 2011.

All rights reserved.

For more information, please visit: <http://www.nxp.com>

For sales office addresses, please send an email to: salesaddresses@nxp.com

Date of release: 3 March 2011

Document identifier: TDA8296

Mouser Electronics

Authorized Distributor

Click to View Pricing, Inventory, Delivery & Lifecycle Information:

[NXP:](#)

[TDA8296HN/C1,518](#) [TDA8296HN/C1,551](#) [TDA8296HN/C1,557](#)