

DATA SHEET



BITSTREAM CONVERSION

UDA1351TS 96 kHz IEC 958 audio DAC

Product specification
Supersedes data of 2000 Mar 28
File under Integrated Circuits, IC01

2001 Feb 05

96 kHz IEC 958 audio DAC**UDA1351TS**

CONTENTS			
1	FEATURES	9	LIMITING VALUES
1.1	General	10	THERMAL CHARACTERISTICS
1.2	Control	11	CHARACTERISTICS
1.3	IEC 958 input	12	TIMING CHARACTERISTICS
1.4	Digital sound processing and DAC	13	APPLICATION INFORMATION
2	APPLICATIONS	14	PACKAGE OUTLINE
3	GENERAL DESCRIPTION	15	SOLDERING
4	QUICK REFERENCE DATA	15.1	Introduction to soldering surface mount packages
5	ORDERING INFORMATION	15.2	Reflow soldering
6	BLOCK DIAGRAM	15.3	Wave soldering
7	PINNING	15.4	Manual soldering
8	FUNCTIONAL DESCRIPTION	15.5	Suitability of surface mount IC packages for wave and reflow soldering methods
8.1	Clock regeneration and lock detection	16	DEFINITIONS
8.2	Mute	17	LIFE SUPPORT APPLICATIONS
8.3	Auto mute		
8.4	Data path		
8.4.1	IEC 958 input		
8.4.2	Audio feature processor		
8.4.3	Interpolator		
8.4.4	Noise shaper		
8.4.5	The Filter Stream DAC (FSDAC)		
8.5	Control		
8.5.1	Static pin control mode		
8.5.2	L3 control mode		
8.6	L3 interface		
8.6.1	General		
8.6.2	Device addressing		
8.6.3	Register addressing		
8.6.4	Data write mode		
8.6.5	Data read mode		
8.6.6	initialization string		
8.6.7	Overview of L3 interface registers		
8.6.8	Writable registers		
8.6.9	Readable registers		

96 kHz IEC 958 audio DAC

UDA1351TS

1 FEATURES**1.1 General**

- 2.7 to 3.6 V power supply
- Integrated digital filter and Digital-to-Analog Converter (DAC)
- Master-mode data output and input interface for off-chip sound processing
- $256f_s$ system clock output
- 20-bit data path in interpolator
- High performance
- No analog post filtering required for DAC
- Support sampling frequencies from 28 kHz up to 100 kHz
- The UDA1351TS is fully pin and function compatible with the UDA1350ATS.

1.2 Control

Controlled either by means of static pins or via the L3 microcontroller interface.

1.3 IEC 958 input

- On-chip amplifier for converting IEC 958 input to CMOS levels
- Lock indication signal available on pin LOCK
- Lock indication signal combined on-chip with the Pulse Code Modulation (PCM) status bit; when non-PCM is detected, pin LOCK indicates out-of-lock
- Key channel-status bits available via L3 interface (lock, pre-emphasis, audio sample frequency, two channel PCM indication and clock accuracy).

1.4 Digital sound processing and DAC

- Automatic de-emphasis when using IEC 958 input with 32.0, 44.1 and 48.0 kHz audio sample frequencies
- Soft mute by means of a cosine roll-off circuit selectable via pin MUTE or the L3 interface
- dB linear volume control with 1 dB steps from 0 dB to -60 dB and $-\infty$ dB
- Bass boost and treble control in L3 control mode
- Interpolating filter (f_s to $128f_s$) by means of a cascade of a recursive filter and a FIR filter
- Third order noise shaper operating at $128f_s$ generates the bitstream for the DAC
- Filter Stream DAC (FSDAC).

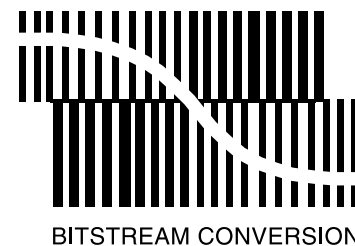
**2 APPLICATIONS**

Digital audio systems.

3 GENERAL DESCRIPTION

Available in two versions:

- UDA1351TS:
 - only IEC 958 input to DAC in SSOP28 package.
- UDA1351H:
 - full featured version in QFP44 package.

The UDA1351TS is a single chip IEC 958 audio decoder with an integrated stereo DAC employing bitstream conversion techniques.

A lock indication signal is available on pin LOCK, indicating that the IEC 958 decoder is locked. This pin is also used to indicate whether PCM data is applied to the input or not. When non-PCM data is detected, the device indicates out-of-lock.

By default, the DAC output and the data output interface are muted when the decoder is out-of-lock. However, this setting can be overruled in the L3 control mode.

96 kHz IEC 958 audio DAC

UDA1351TS

4 QUICK REFERENCE DATA

SYMBOL	PARAMETER	CONDITIONS	MIN.	TYP.	MAX.	UNIT
Supplies						
V _{DDD}	digital supply voltage		2.7	3.0	3.6	V
V _{DDA}	analog supply voltage		2.7	3.0	3.6	V
I _{DDA(DAC)}	analog supply current of DAC	power-on	–	8.0	–	mA
		Power-down	–	750	–	μA
I _{DDA(PLL)}	analog supply current of PLL	at 48 kHz	–	0.7	–	mA
		at 96 kHz	–	1.0	–	mA
I _{DDD(C)}	digital supply current of core	at 48 kHz	–	16.0	–	mA
		at 96 kHz	–	24.5	–	mA
I _{DDD}	digital supply current	at 48 kHz	–	2.0	–	mA
		at 96 kHz	–	3.0	–	mA
P	power consumption at 48 kHz	DAC in playback mode	–	80	–	mW
		DAC in Power-down mode	–	58	–	mW
	power consumption at 96 kHz	DAC in playback mode	–	109	–	mW
		DAC in Power-down mode	–	87	–	mW
General						
t _{rst}	reset active time		–	250	–	μs
T _{amb}	ambient temperature		–40	–	+85	°C
Digital-to-analog converter						
V _{o(rms)}	output voltage (RMS value)	note 1	–	900	–	mV
(THD + N)/S	total harmonic distortion-plus-noise to signal ratio	f _i = 1.0 kHz tone at 48 kHz	–	–90	–85	dB
		at 0 dB	–	–60	–55	dB
		at –40 dB; A-weighted	–	–85	–80	dB
		at –40 dB; A-weighted	–	–57	–52	dB
S/N	signal-to-noise ratio at 48 kHz	f _i = 1.0 kHz tone; code = 0; A-weighted	95	100	–	dB
	signal-to-noise ratio at 96 kHz	f _i = 1.0 kHz tone; code = 0; A-weighted	95	100	–	dB
α _{CS}	channel separation	f _i = 1.0 kHz tone	–	96	–	dB
ΔV _o	unbalance of output voltages	f _i = 1.0 kHz tone	–	0.1	0.4	dB

Note

1. The output voltage of the DAC is proportional to the DAC power supply voltage.

5 ORDERING INFORMATION

TYPE NUMBER	PACKAGE		
	NAME	DESCRIPTION	VERSION
UDA1351TS	SSOP28	plastic shrink small outline package; 28 leads; body width 5.3 mm	SOT341-1

96 kHz IEC 958 audio DAC

UDA1351TS

6 BLOCK DIAGRAM

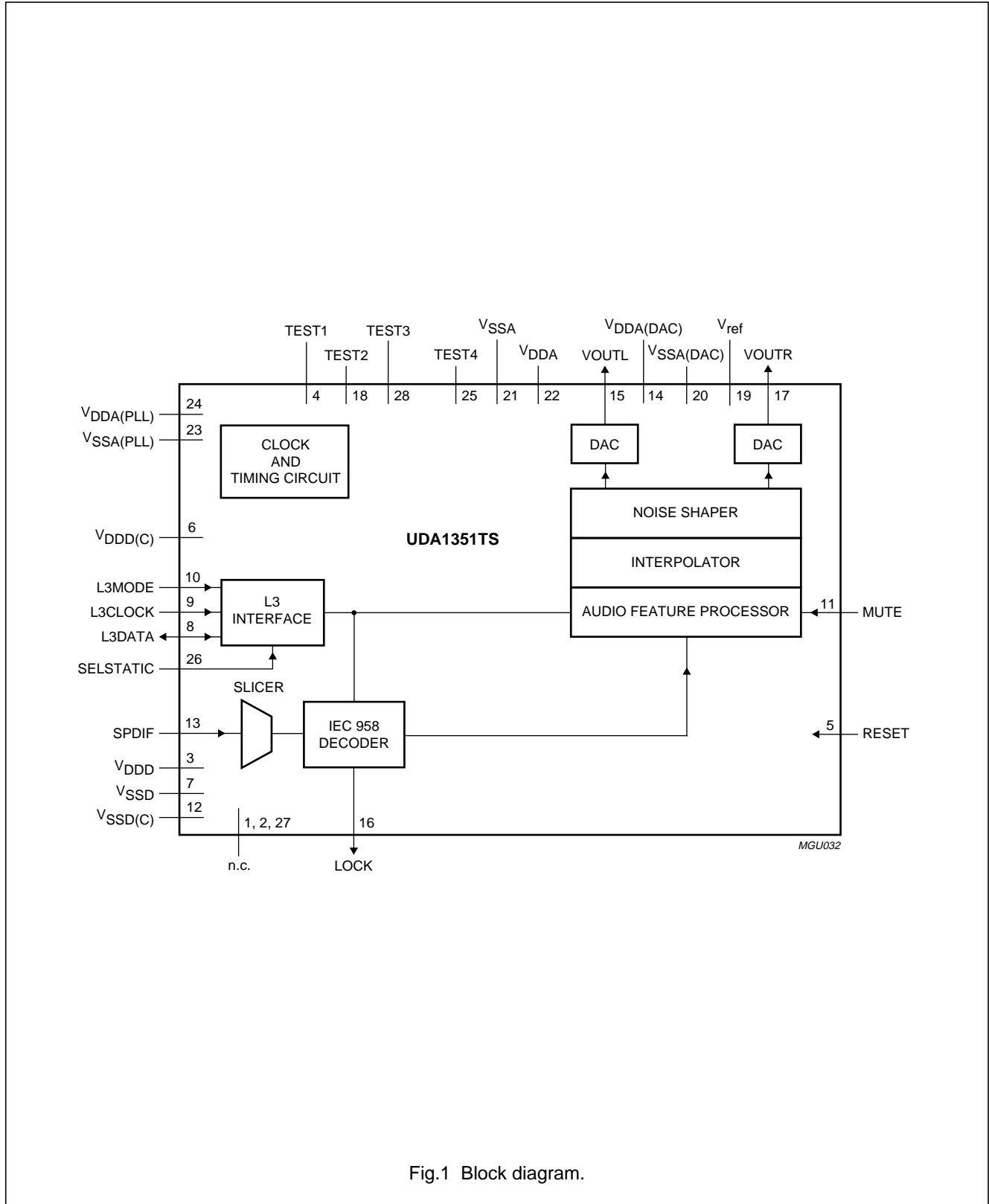

Fig.1 Block diagram.

96 kHz IEC 958 audio DAC

UDA1351TS

7 PINNING

SYMBOL	PIN	TYPE ⁽¹⁾	DESCRIPTION
n.c.	1	–	not connected
n.c.	2	–	not connected
V _{DDD}	3	DS	digital supply voltage
TEST1	4	DID	test pin 1; must be connected to digital ground (V _{SSD})
RESET	5	DISD	reset input
V _{DDD(C)}	6	DS	digital supply voltage for core
V _{SSD}	7	DGND	digital ground
L3DATA	8	DIOS	L3 interface data input and output
L3CLOCK	9	DIS	L3 interface clock input
L3MODE	10	DIS	L3 interface mode input
MUTE	11	DID	mute control input
V _{SSD(C)}	12	DGND	digital ground
SPDIF	13	AI	IEC 958 channel input
V _{DDA(DAC)}	14	AS	analog supply voltage for DAC
VOU _{TL}	15	AO	analog DAC left channel output
LOCK	16	DO	SPDIF and PLL lock indicator output
VOU _{TR}	17	AO	analog DAC right channel output
TEST2	18	DID	test pin 2; must be connected to digital ground (V _{SSD})
V _{ref}	19	A	DAC reference voltage
V _{SSA(DAC)}	20	AGND	analog ground for DAC
V _{SSA}	21	AGND	analog ground
V _{DDA}	22	AS	analog supply voltage
V _{SSA(PLL)}	23	AGND	analog ground for PLL
V _{DDA(PLL)}	24	AS	analog supply voltage for PLL
TEST4	25	DIU	test pin 4; must be connected to the digital supply voltage (V _{DDD})
SELSTATIC	26	DIU	static pin control selection input
n.c.	27	–	not connected
TEST3	28	DISD	test pin 3; must be connected to digital ground (V _{SSD})

Note

1. See Table 1.

96 kHz IEC 958 audio DAC

UDA1351TS

Table 1 Pin type references

PIN TYPE	DESCRIPTION
DS	digital supply
DGND	digital ground
AS	analog supply
AGND	analog ground
DI	digital input
DIS	digital Schmitt-triggered input
DID	digital input with internal pull-down resistor
DISD	digital Schmitt-triggered input with internal pull-down resistor
DIU	digital input with internal pull-up resistor
DO	digital output
DIO	digital input and output
DIOS	digital Schmitt-triggered input and output
A	analog reference voltage
AI	analog input
AO	analog output

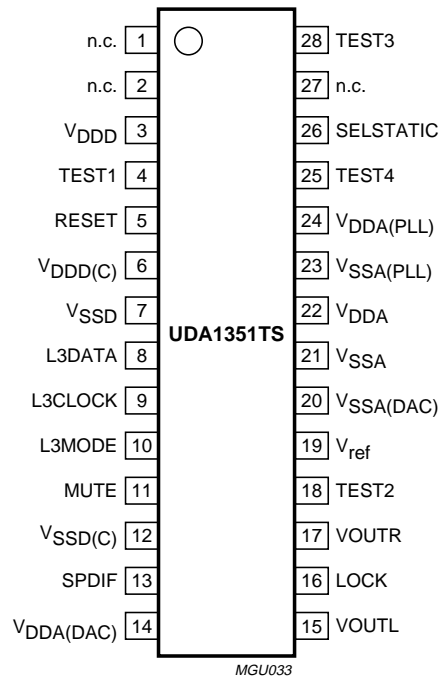

Fig.2 Pin configuration.

96 kHz IEC 958 audio DAC

UDA1351TS

8 FUNCTIONAL DESCRIPTION

The UDA1351TS is a low cost audio IEC 958 decoder with an on-board DAC. The minimum audio input sampling frequency conforming to the IEC958 standard is 28.0 kHz and the maximum audio sampling frequency is 100.0 kHz.

8.1 Clock regeneration and lock detection

The UDA1351TS contains an on-board PLL for regenerating a system clock from the IEC 958 input bitstream.

Note: If there is no input signal, the PLL generates a minimum frequency and the output spectrum shifts accordingly. Since the analog output does not have an analog mute, this means noise that is out of band under normal conditions can move into the audio band.

When the on-board clock locks to the incoming frequency, the lock indicator bit is set and can be read via the L3 interface. Internally, the PLL lock indication is combined with the PCM status bit of the input data stream. When both the IEC 958 decoder and the on-board clock have locked to the incoming signal and the input data stream is PCM data, pin LOCK will be asserted. However, when the IC is locked but the PCM status bit reports non-PCM data, pin LOCK is returned to LOW level.

The lock indication output can be used, for example, for muting purposes. The lock signal can be used to drive an external analog muting circuit to prevent out of band noise from becoming audible when the PLL runs at its minimum frequency (e.g. when there is no SPDIF input signal).

An example of the mute circuit is illustrated in Fig.3 where V_{DD} is the positive power supply and V_{SS} is the negative power supply.

8.2 Mute

The UDA1351TS is equipped with a cosine roll-off mute in the DSP data path of the DAC part. Muting the DAC, by pin MUTE (in static mode) or via bit MT (in L3 mode), will result in a soft mute, as shown in Fig.4. The cosine roll-off soft mute takes 32×32 samples = 24 ms at 44.1 kHz sampling frequency.

When operating in the L3 control mode, the device will mute on start-up. In L3 mode, it is necessary to explicitly switch off the mute for audio output by means of the MT bit in the L3 register.

In the L3 mode, pin MUTE does not have any function (the same holds for several other pins) and can either be left open-circuit (since it has an internal pull-down resistor) or be connected to ground.

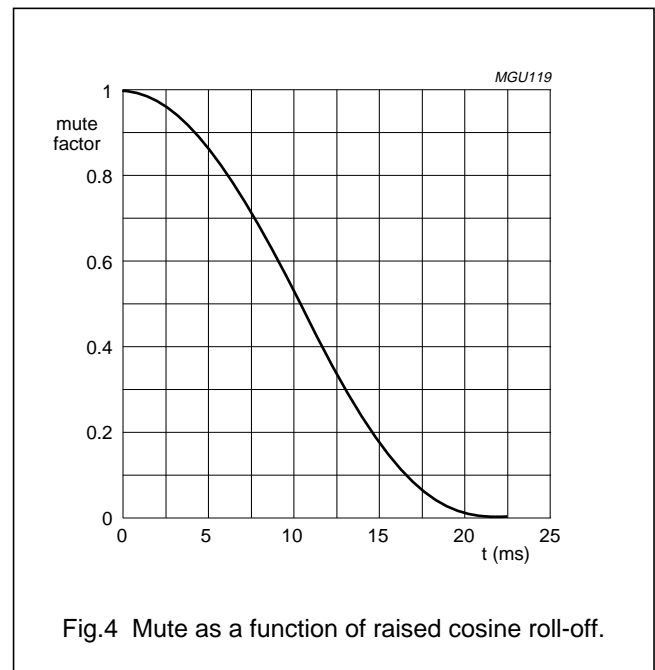
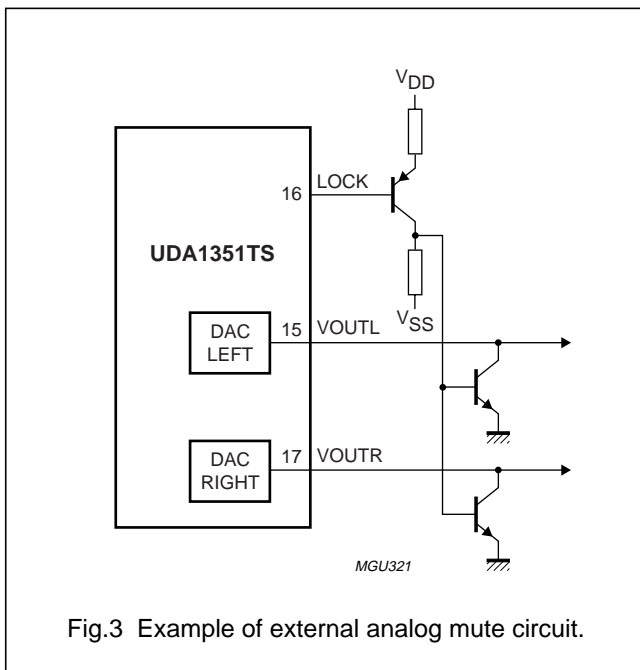

96 kHz IEC 958 audio DAC

UDA1351TS

8.3 Auto mute

By default, the DAC outputs will be muted until the IC is locked, regardless of the level on pin MUTE (in static mode) or the state of bit MT of the sound feature register (in L3 mode). In this way, only valid data will be passed to the outputs. This mute is done in the SPDIF interface and is a hard mute, not a cosine roll-off mute.

If needed, this muting can be bypassed by setting bit AutoMT to logic 0 via the L3 interface. As a result, the IC will no longer mute during out-of-lock situations.

8.4 Data path

The UDA1351TS data path consists of the IEC 958 decoder, the audio feature processor, digital interpolator and noise shaper and the DACs.

8.4.1 IEC 958 INPUT

The UDA1351TS IEC 958 decoder features an on-chip amplifier with hysteresis, which amplifies the IEC 958 input signal to CMOS level (see Fig.5).

All 24 bits of data for left and right are extracted from the input bitstream as well as several of the IEC 958 key channel-status bits.

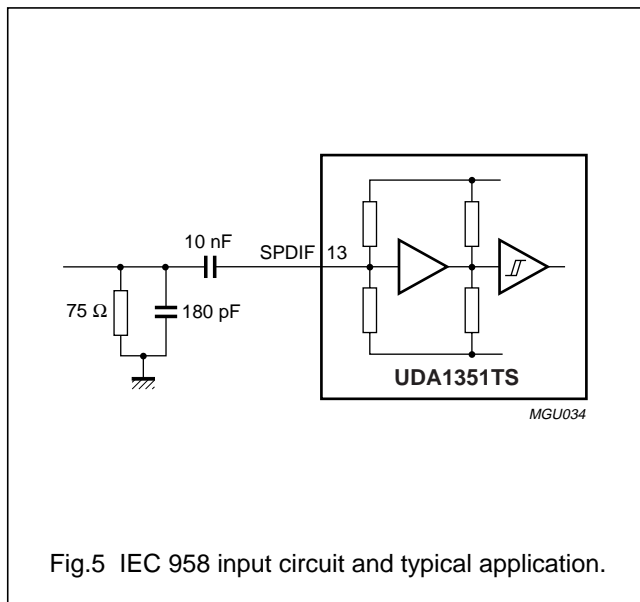

Fig.5 IEC 958 input circuit and typical application.

The extracted key parameters are:

- Pre-emphasis
- Audio sample frequency
- Two-channel PCM indicator
- Clock accuracy.

Both the lock indicator and the key channel status bits are accessible via the L3 interface.

The UDA1351TS supports the following sample frequencies and data bit rates:

- $f_s = 32.0$ kHz, resulting in a data rate of 2.048 Mbits/s
- $f_s = 44.1$ kHz, resulting in a data rate of 2.8224 Mbits/s
- $f_s = 48.0$ kHz, resulting in a data rate of 3.072 Mbits/s
- $f_s = 64.0$ kHz, resulting in a data rate of 4.096 Mbits/s
- $f_s = 88.2$ kHz, resulting in a data rate of 5.6448 Mbits/s
- $f_s = 96.0$ kHz, resulting in a data rate of 6.144 Mbits/s.

The UDA1351TS supports timing levels I, II and III, as specified by the IEC 958 standard.

8.4.2 AUDIO FEATURE PROCESSOR

The audio feature processor automatically provides de-emphasis for the IEC 958 data stream in the static pin control mode and default mute at start-up in the L3 control mode.

When used in the L3 control mode, it provides the following additional features:

- Volume control, using 6 bits
- Bass boost control, using 4 bits
- Treble control, using 2 bits
- Mode selection of the sound processing bass boost and treble filters: flat, minimum and maximum
- Soft mute control with raised cosine roll-off
- De-emphasis selection of the incoming data stream for $f_s = 32.0, 44.1$ and 48.0 kHz.

8.4.3 INTERPOLATOR

The UDA1351TS includes an on-board interpolating filter which converts the incoming data stream from $1f_s$ to $128f_s$ by cascading a recursive filter and a FIR filter.

96 kHz IEC 958 audio DAC

UDA1351TS

Table 2 Interpolator characteristics

PARAMETER	CONDITIONS	VALUE (dB)
Pass-band ripple	0 to $0.45f_s$	± 0.03
Stop band	$>0.65f_s$	-50
Dynamic range	0 to $0.45f_s$	115
DC gain	-	-3.5

8.4.4 NOISE SHAPER

The third-order noise shaper operates at $128f_s$. It shifts in-band quantization noise to frequencies well above the audio band. This noise shaping technique enables high signal-to-noise ratios to be achieved. The noise shaper output is converted to an analog signal using a filter stream DAC.

8.4.5 THE FILTER STREAM DAC (FSDAC)

The FSDAC is a semi-digital reconstruction filter that converts the 1-bit data stream of the noise shaper to an analog output voltage. The filter coefficients are implemented as current sources and are summed at virtual ground of the output operational amplifier. In this way, very high signal-to-noise performance and low clock jitter sensitivity is achieved.

A post-filter is not needed due to the inherent filter function of the DAC. On-board amplifiers convert the FSDAC output current to an output voltage signal capable of driving a line output.

The output voltage of the FSDAC is scaled proportionally with the power supply voltage.

8.5 Control

The UDA1351TS can be controlled by means of static pins or via the L3 interface. For optimum use of the features of the UDA1351TS, the L3 control mode is recommended since only basic functions are available in the static pin control mode.

It should be noted that the static pin control mode and L3 control mode are mutually exclusive. In the static pin control mode, pins L3MODE and L3DATA are used to select the format for the data output and input interface.

8.5.1 STATIC PIN CONTROL MODE

The default values for all non-pin controlled settings are identical to the default values at start-up in the L3 control mode.

Table 3 Pin description of static pin control mode

PIN	NAME	VALUE	FUNCTION
Mode selection pin			
26	SELSTATIC	1	select static pin control mode; must be connected to V_{DD}
Input pins			
5	RESET	0	normal operation
		1	reset
8	L3DATA	0	must be connected to V_{SSD}
9	L3CLOCK	0	must be connected to V_{SSD}
10	L3MODE	0	must be connected to V_{SSD}
11	MUTE	0	normal operation
		1	mute active
Status pin			
16	LOCK	0	clock regeneration and IEC 958 decoder out-of-lock or non-PCM data detected
		1	clock regeneration and IEC 958 decoder locked and PCM data detected

96 kHz IEC 958 audio DAC

UDA1351TS

PIN	NAME	VALUE	FUNCTION
Test pins			
4	TEST1	0	must be connected to digital ground (V_{SSD})
18	TEST2	0	must be connected to digital ground (V_{SSD})
25	TEST4	1	must be connected to digital supply voltage (V_{DDD})
28	TEST3	0	must be connected to digital ground (V_{SSD})

8.5.2 L3 CONTROL MODE

The L3 control mode allows maximum flexibility in controlling the UDA1351TS.

It should be noted that, in the L3 control mode, several base-line functions are still controlled by pins on the device and that, on start-up in the L3 control mode, the output is explicitly muted by bit MT via the L3 interface.

Table 4 Pin description in the L3 control mode

PIN	NAME	VALUE	FUNCTION
Mode selection pin			
26	SELSTATIC	0	select L3 control mode; must be connected to V_{SSD}
Input pins			
5	RESET	0	normal operation
		1	reset
8	L3DATA	–	must be connected to the L3-bus
9	L3CLOCK	–	must be connected to the L3-bus
10	L3MODE	–	must be connected to the L3-bus
Status pin			
16	LOCK	0	clock regeneration and IEC 958 decoder out-of-lock or non-PCM data detected
		1	clock regeneration and IEC 958 decoder locked and PCM data detected
Test pins			
4	TEST1	0	must be connected to ground (V_{SSD})
18	TEST2	0	must be connected to ground (V_{SSD})
25	TEST4	1	must be connected to digital supply voltage (V_{DDD})
28	TEST3	0	must be connected to ground (V_{SSD})

96 kHz IEC 958 audio DAC

UDA1351TS

8.6 L3 interface**8.6.1 GENERAL**

The UDA1351TS has an L3 microcontroller interface and all the digital sound processing features and various system settings can be controlled by a microcontroller.

The controllable settings are:

- Restoring L3 defaults
- Power-on
- Selection of filter mode and settings of treble and bass boost
- Volume settings
- Selection of soft mute via cosine roll-off and bypass of auto mute
- Selection of de-emphasis (only effective in L3 control mode).

The readable settings are:

- Mute status of interpolator
- PLL locked
- SPDIF input signal locked
- Audio Sample Frequency (ASF)
- Valid PCM data detected
- Pre-emphasis of the IEC 958 input signal
- ACcuracy of the Clock (ACC).

The exchange of data and control information between the microcontroller and the UDA1351TS is LSB first and is accomplished through a serial hardware L3 interface comprising the following pins:

- L3DATA: data line
- L3MODE: mode line
- L3CLK: clock line.

The exchange of bytes via the L3 interface is LSB first.

The L3 format has two modes of operation:

- Address mode
- Data transfer mode.

The address mode is used to select a device for a subsequent data transfer. The address mode is characterized by L3MODE being LOW and a burst of 8 pulses on L3CLOCK, accompanied by eight bits (see Fig.6). The data transfer mode is characterized by L3MODE being HIGH and is used to transfer one or more bytes representing a register address, instruction or data.

Basically, two types of data transfers can be defined:

- Write action: data transfer **to** the device
- Read action: data transfer **from** the device.

Remark: when the device is powered up, at least one L3CLOCK pulse must be given to the L3 interface to wake up the interface before starting sending to the device, see Fig.6. This is only needed once after the device is powered up.

8.6.2 DEVICE ADDRESSING

The device address consists of one byte with:

- Data Operating Mode (DOM) bits 0 and 1 representing the type of data transfer (see Table 5)
- Address bits 2 to 7 representing a 6-bit device address.

Table 5 Selection of data transfer

DOM		TRANSFER
BIT 0	BIT 1	
0	0	not used
1	0	not used
0	1	write data or prepare read
1	1	read data

8.6.3 REGISTER ADDRESSING

After sending the device address (including DOM bits), indicating whether the information is to be read or written, one data byte is sent using bit 0 to indicate whether the information will be read or written and bits 1 to 7 for the destination register address.

Basically, there are three methods for register addressing:

1. Addressing for write data: bit 0 is logic 0 indicating a write action to the destination register, followed by bits 1 to 7 indicating the register address (see Fig.6)
2. Addressing for prepare read: bit 0 is logic 1, indicating that data will be read from the register (see Fig.7)
3. Addressing for data read action. Here, the device returns a register address prior to sending data from that register. When bit 0 is logic 0, the register address is valid; when bit 0 is logic 1, the register address is invalid.

96 KHz IEC 958 audio DAC

UDA1351TS

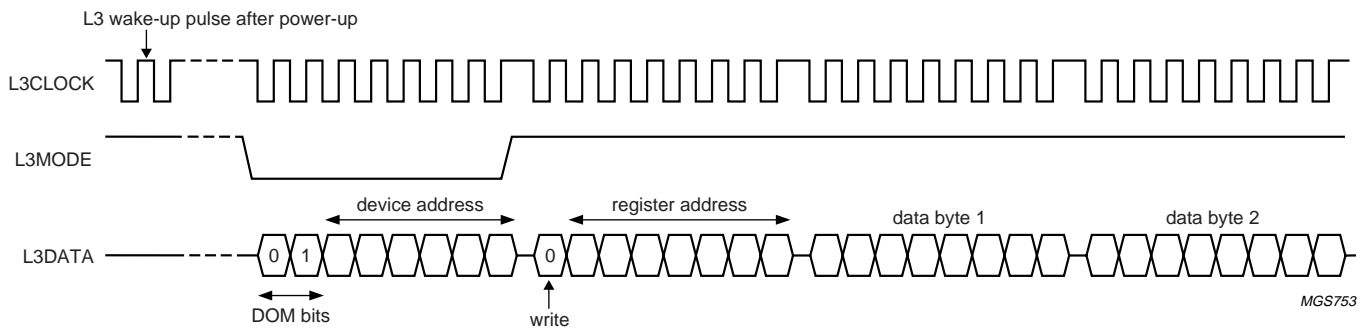

Fig.6 Data write mode (for L3 version 2).

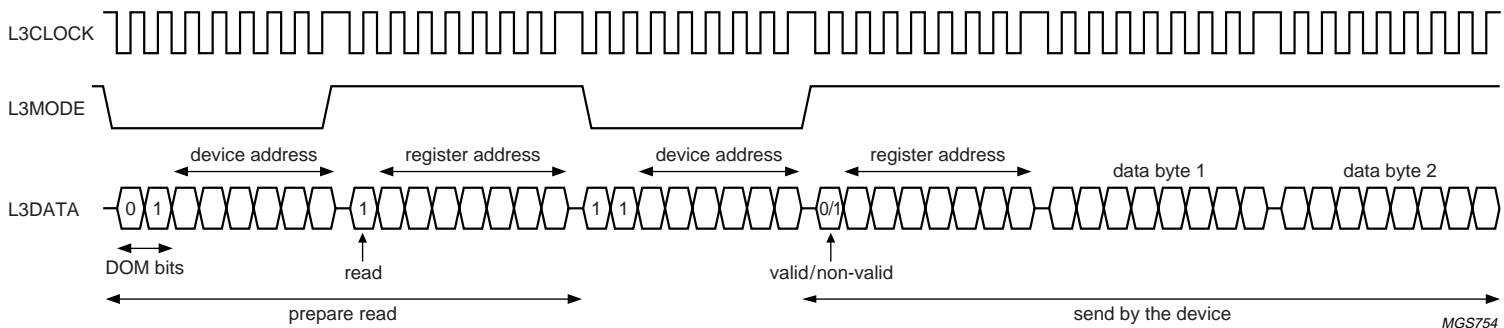

Fig.7 Data read mode.

96 kHz IEC 958 audio DAC

UDA1351TS

8.6.4 DATA WRITE MODE

The data write mode is explained in the signal diagram of Fig.6. For writing data to a device, four bytes must be sent (see Table 6):

1. One byte starting with '01' for signalling the write action to the device, followed by the device address ('011000' for the UDA1351TS)
2. One byte starting with a '0' for signalling the write action, followed by seven bits indicating the destination address in binary format with A6 being the MSB and A0 being the LSB
3. Two data bytes with D15 being the MSB and D0 being the LSB.

It should be noted that each time a new destination register address needs to be written, the device address must be sent again.

8.6.5 DATA READ MODE

To read data from the device, a prepare read must first be done and then data read. The data read mode is explained in the signal diagram of Fig.7.

For reading data from a device, the following six bytes are involved (see Table 7):

1. One byte with the device address, including '01' for signalling the write action to the device
2. One byte is sent with the register address from which data needs to be read. This byte starts with a '1', which indicates that there will be a read action from the register, followed again by seven bits for the destination address in binary format, with A6 being the MSB and A0 being the LSB
3. One byte with the device address, including '11' is sent to the device. The '11' indicates that the device must write data to the microcontroller
4. One byte, sent by the device to the bus, with the (requested) register address and a flag bit indicating whether the requested register was valid (bit is logic 0) or invalid (bit is logic 1)
5. Two bytes, sent by the device to the bus, with the data information in binary format, with D15 being the MSB and D0 being the LSB.

Table 6 L3 write data

BYTE	L3 MODE	ACTION	FIRST IN TIME					LATEST IN TIME			
			BIT 0	BIT 1	BIT 2	BIT 3	BIT 4	BIT 5	BIT 6	BIT 7	
1	address	device address	0	1	0	1	1	0	0	0	
2	data transfer	register address	0	A6	A5	A4	A3	A2	A1	A0	
3	data transfer	data byte 1	D15	D14	D13	D12	D11	D10	D9	D8	
4	data transfer	data byte 2	D7	D6	D5	D4	D3	D2	D1	D0	

Table 7 L3 read data

BYTE	L3 MODE	ACTION	FIRST IN TIME					LATEST IN TIME			
			BIT 0	BIT 1	BIT 2	BIT 3	BIT 4	BIT 5	BIT 6	BIT 7	
1	address	device address	0	1	0	1	1	0	0	0	
2	data transfer	register address	1	A6	A5	A4	A3	A2	A1	A0	
3	address	device address	1	1	0	1	1	0	0	0	
4	data transfer	register address	0 or 1	A6	A5	A4	A3	A2	A1	A0	
5	data transfer	data byte 1	D15	D14	D13	D12	D11	D10	D9	D8	
6	data transfer	data byte 2	D7	D6	D5	D4	D3	D2	D1	D0	

96 kHz IEC 958 audio DAC

UDA1351TS

8.6.6 INITIALIZATION STRING

For proper and reliable operation, the UDA1351TS must be initialized in the L3 control mode. This is required to have the PLL start up after powering up of the device under all conditions. The initialization string is given in Table 8.

Table 8 L3 initialization string and set defaults after power-up.

BYTE	L3 MODE	ACTION		FIRST IN TIME					LATEST IN TIME		
				BIT 0	BIT 1	BIT 2	BIT 3	BIT 4	BIT 5	BIT 6	BIT 7
1	address	init string	device address	0	1	0	1	1	0	0	0
2	data transfer		register address	0	1	0	0	0	0	0	0
3	data transfer		data byte 1	0	0	0	0	0	0	0	0
4	data transfer		data byte 2	0	0	0	0	0	0	1	1
5	address	set defaults	device address	0	1	0	1	1	0	0	0
6	data transfer		register address	0	1	1	1	1	1	1	1
7	data transfer		data byte 1	0	0	0	0	0	0	0	0
8	data transfer		data byte 2	0	0	0	0	0	0	0	0

96 kHz IEC 958 audio DAC

UDA1351TS

8.6.7 OVERVIEW OF L3 INTERFACE REGISTERS

Table 9 UDA1351TS register map

ADDR	FUNCTION	BIT															
		D15	D14	D13	D12	D11	D10	D9	D8	D7	D6	D5	D4	D3	D2	D1	D0
Writable settings																	
00H	system parameters			PON													
	default			1			0 ⁽¹⁾	0 ⁽¹⁾			1 ⁽²⁾		0 ⁽¹⁾	0 ⁽¹⁾			
10H	sound features			M1	M0	BB3	BB2	BB1	BB0				TR1	TR0	DE1	DE0	MT
	default			0	0	0	0	0	0				0	0	0	0	1
11H	volume control DAC											VC5	VC4	VC3	VC2	VC1	VC0
	default											0	0	0	0	0	0
40H	multiplex parameters															Auto MT	RST PLL
	default											0 ⁽¹⁾	0 ⁽¹⁾	0 ⁽¹⁾	0 ⁽¹⁾	1	0
7FH	restore L3 defaults																
Readable settings																	
18H	interpolator parameters																MT stat
38H	SPDIF input and lock parameters						PLL lock		SPD lock	ASF1	ASF0	PCM stat		PRE		ACC1	ACC0

Notes

1. When writing new settings via the L3 interface, these bits should always remain at logic 0 (default value) to warrant correct operation.
2. When writing new settings via the L3 interface, these bits should always remain at logic 1 (default value) to warrant correct operation.

96 kHz IEC 958 audio DAC

UDA1351TS

8.6.8 WRITABLE REGISTERS

8.6.8.1 Restoring L3 defaults

By writing to the 7FH register, all L3 control values are restored to their default values. Only the L3 interface is affected: the system will not be reset. Consequently, readable registers that are not reset can be affected.

8.6.8.2 Power-on

A 1-bit value to switch the DAC on and off.

Table 10 Power-on setting

PON	FUNCTION
0	Power-down
1	power-on (default setting)

8.6.8.3 Filter mode selection

A 2-bit value to program the mode for the sound processing filters of bass boost and treble.

Table 11 Filter mode settings

M1	M0	FUNCTION
0	0	flat (default setting)
0	1	minimum
1	0	
1	1	maximum

8.6.8.4 Treble

A 2-bit value to program the treble setting, in combination with the filter mode settings. At $f_s = 44.1$ kHz, the -3 dB point for minimum setting is 3.0 kHz and the -3 dB point for maximum setting is 1.5 kHz. The default value is '00'.

Table 12 Treble settings

TR1	TR0	LEVEL (dB)		
		FLAT	MIN.	MAX.
0	0	0	0	0
0	1	0	2	2
1	0	0	4	4
1	1	0	6	6

8.6.8.5 Bass boost

A 4-bit value to program the bass boost setting, in combination with the filter mode settings. At $f_s = 44.1$ kHz, the -3 dB point for minimum setting is 250 Hz and the -3 dB point for maximum setting is 300 Hz. The default value is '0000'.

Table 13 Bass boost settings

BB3	BB2	BB1	BB0	LEVEL (dB)		
				FLAT	MIN.	MAX.
0	0	0	0	0	0	0
0	0	0	1	0	2	2
0	0	1	0	0	4	4
0	0	1	1	0	6	6
0	1	0	0	0	8	8
0	1	0	1	0	10	10
0	1	1	0	0	12	12
0	1	1	1	0	14	14
1	0	0	0	0	16	16
1	0	0	1	0	18	18
1	0	1	0	0	18	20
1	0	1	1	0	18	22
1	1	0	0	0	18	24
1	1	0	1	0	18	24
1	1	1	0	0	18	24
1	1	1	1	0	18	24

8.6.8.6 De-emphasis

A 2-bit value to enable the digital de-emphasis filter.

Table 14 De-emphasis selection

DE1	DE0	FUNCTION
0	0	other (default setting)
0	1	$f_s = 32.0$ kHz
1	0	$f_s = 44.1$ kHz
1	1	$f_s = 48.0$ kHz

96 kHz IEC 958 audio DAC

UDA1351TS

8.6.8.7 Soft mute

A 1-bit value to enable the digital mute.

Table 15 Soft mute selection

MT	FUNCTION
0	no muting
1	muting (default setting)

8.6.8.8 Volume control

A 6-bit value to program the left and right channel volume attenuation. The range is from 0 to $-\infty$ dB in steps of 1 dB.

Table 16 Volume settings

VC5	VC4	VC3	VC2	VC1	VC0	VOLUME (dB)
0	0	0	0	0	0	0
0	0	0	0	0	1	0
0	0	0	0	1	0	-1
0	0	0	0	1	1	-2
:	:	:	:	:	:	:
1	1	0	0	1	1	-51
1	1	0	1	0	0	
1	1	0	1	0	1	-52
1	1	0	1	1	0	
1	1	0	1	1	1	-54
1	1	1	0	0	0	
1	1	1	0	0	1	-57
1	1	1	0	1	0	
1	1	1	0	1	1	
1	1	1	1	0	0	-60
1	1	1	1	0	1	
1	1	1	1	1	0	$-\infty$
1	1	1	1	1	1	

8.6.8.9 Auto mute

A 1-bit value to activate mute during out-of-lock. In normal operation, the output is automatically hard muted when an out-of-lock situation is detected. Setting this bit to logic 0 will disable that function.

Table 17 Auto mute setting

Auto MT	FUNCTION
0	do not mute output during out-of-lock
1	mute output during out-of-lock (default setting)

8.6.8.10 PLL reset

A 1-bit value to reset the PLL. This is the bit which is set in the initialization string. When this bit is asserted, the PLL will be reset and the output clock of the PLL will be forced to its lowest value, which is in the area of a few MHz.

Table 18 PLL reset

RST PLL	FUNCTION
0	normal operation (default)
1	PLL is reset

8.6.9 READABLE REGISTERS

8.6.9.1 Mute status

A 1-bit value indicating whether the interpolator is muting or not muting.

Table 19 Interpolator mute status

MT stat	FUNCTION
0	no muting
1	muting

8.6.9.2 PLL lock detection

A 1-bit value indicating that the clock regeneration is locked.

Table 20 PLL lock indication

PLL lock	FUNCTION
0	out-of-lock
1	locked

96 kHz IEC 958 audio DAC

UDA1351TS

8.6.9.3 SPDIF lock detection

A 1-bit value indicating the IEC 958 decoder is locked and is decoding correct data.

Table 21 SPDIF lock detection

SPD lock	FUNCTION
0	not locked or non-PCM data detected
1	locked and PCM data detected

8.6.9.4 Audio sample frequency detection

A 2-bit value indicating the audio sample frequency of the IEC 958 input signal.

Table 22 Audio sample frequency detection

ASF1	ASF0	FUNCTION
0	0	44.1 kHz
0	1	undefined
1	0	48.0 kHz
1	1	32.0 kHz

8.6.9.5 PCM detection

A 1-bit value which indicates whether the IEC 958 input contains PCM audio data or other binary data.

Table 23 Two channel PCM input detection

PCM stat	FUNCTION
0	input with two channel PCM data
1	input without two channel PCM data

8.6.9.6 Pre-emphasis detection

A 1-bit value that indicates whether the pre-emphasis bit was set on the IEC 958 input signal or not set.

Table 24 Pre-emphasis detection

PRE	FUNCTION
0	no pre-emphasis
1	pre-emphasis

8.6.9.7 Clock accuracy detection

A 2-bit value indicating whether the timing accuracy of the IEC 958 input signal conforms to the IEC 958 specification.

Table 25 Input signal accuracy detection

ACC1	ACC0	FUNCTION
0	0	level II
0	1	level I
1	0	level III
1	1	undefined

96 kHz IEC 958 audio DAC

UDA1351TS

9 LIMITING VALUES

In accordance with the Absolute Maximum Rating System (IEC 60134).

SYMBOL	PARAMETER	CONDITIONS	MIN.	MAX.	UNIT
V_{DD}	supply voltage	note 1	2.7	5.0	V
T_{xtal}	crystal temperature		-25	+150	°C
T_{stg}	storage temperature		-65	+125	°C
T_{amb}	ambient temperature		-40	+85	°C
V_{es}	electrostatic handling voltage	Human Body Model (HBM); note 2	-2000	+2000	V
		Machine Model (MM); note 3	-200	+200	V
$I_{lu(prot)}$	latch-up protection current	$T_{amb} = 125\text{ °C}; V_{DD} = 3.6\text{ V}$	-	200	mA
$I_{sc(DAC)}$	short-circuit current of DAC	$T_{amb} = 0\text{ °C}; V_{DD} = 3\text{ V};$ note 4			
		output short circuited to $V_{SSA(DAC)}$	-	482	mA
		output short circuited to $V_{DDA(DAC)}$	-	346	mA

Notes

1. All V_{DD} and V_{SS} connections must be made to the same power supply.
2. JEDEC class 2 compliant.
3. JEDEC class B compliant, except pin $V_{SSA(PLL)}$, which can withstand ESD pulses of -130 to +130 V.
4. DAC operation after short circuiting cannot be warranted.

10 THERMAL CHARACTERISTICS

SYMBOL	PARAMETER	CONDITIONS	VALUE	UNIT
$R_{th(j-a)}$	thermal resistance from junction to ambient	in free air	85	K/W

96 kHz IEC 958 audio DAC

UDA1351TS

11 CHARACTERISTICS

$V_{DD} = V_{DDA} = 3.0$ V; IEC 958 input with $f_s = 48.0$ kHz; $T_{amb} = 25$ °C; $R_L = 5$ k Ω ; all voltages measured with respect to ground; unless otherwise specified.

SYMBOL	PARAMETER	CONDITIONS	MIN.	TYP.	MAX.	UNIT
Supplies; note 1						
V_{DDA}	analog supply voltage		2.7	3.0	3.6	V
$V_{DDA(DAC)}$	analog supply voltage for DAC		2.7	3.0	3.6	V
$V_{DDA(PLL)}$	analog supply voltage for PLL		2.7	3.0	3.6	V
V_{DDD}	digital supply voltage		2.7	3.0	3.6	V
$V_{DDD(C)}$	digital supply voltage for core		2.7	3.0	3.6	V
$I_{DDA(DAC)}$	analog supply current of DAC	power-on	–	8.0	–	mA
		Power-down	–	750	–	μ A
$I_{DDA(PLL)}$	analog supply current of PLL	at 48 kHz	–	0.7	–	mA
		at 96 kHz	–	1.0	–	mA
$I_{DDD(C)}$	digital supply current of core	at 48 kHz	–	16.0	–	mA
		at 96 kHz	–	24.5	–	mA
I_{DDD}	digital supply current	at 48 kHz	–	2.0	–	mA
		at 96 kHz	–	3.0	–	mA
P	power consumption at 48 kHz	DAC in playback mode	–	80	–	mW
		DAC in Power-down mode	–	58	–	mW
	power consumption at 96 kHz	DAC in playback mode	–	109	–	mW
		DAC in Power-down mode	–	87	–	mW
Digital input pins						
V_{IH}	HIGH-level input voltage		$0.8V_{DD}$	–	$V_{DD} + 0.5$	V
V_{IL}	LOW-level input voltage		–0.5	–	$+0.2V_{DD}$	V
$V_{hys(RESET)}$	hysteresis voltage on pin RESET		–	0.8	–	V
$ I_{LI} $	input leakage current		–	–	10	μ A
C_i	input capacitance		–	–	10	pF
$R_{pu(int)}$	internal pull-up resistance		16	33	78	k Ω
$R_{pd(int)}$	internal pull-down resistance		16	33	78	k Ω
Digital output pins						
V_{OH}	HIGH-level output voltage	$I_{OH} = -2$ mA	$0.85V_{DD}$	–	–	V
V_{OL}	LOW-level output voltage	$I_{OL} = 2$ mA	–	–	0.4	V
$I_{L(max)}$	maximum load current		–	3	–	mA
Digital-to-analog converter; note 2						
V_{ref}	reference voltage	measured with respect to V_{SSA}	$0.45V_{DDA}$	$0.50V_{DDA}$	$0.55V_{DDA}$	V
$V_{o(rms)}$	output voltage (RMS value)		–	900	–	mV

96 kHz IEC 958 audio DAC

UDA1351TS

SYMBOL	PARAMETER	CONDITIONS	MIN.	TYP.	MAX.	UNIT
(THD + N)/S	total harmonic distortion-plus-noise to signal ratio	f _i = 1.0 kHz tone at 48 kHz	–	–90	–85	dB
		at 0 dB	–	–60	–55	dB
		at –40 dB; A-weighted	–	–60	–55	dB
		f _i = 1.0 kHz tone at 96 kHz	–	–85	–80	dB
		at 0 dB	–	–57	–52	dB
		at –40 dB; A-weighted	–	–57	–52	dB
S/N	signal-to-noise ratio at 48 kHz	f _i = 1.0 kHz tone; code = 0; A-weighted	95	100	–	dB
	signal-to-noise ratio at 96 kHz	f _i = 1.0 kHz tone; code = 0; A-weighted	95	100	–	dB
α_{CS}	channel separation	f _i = 1.0 kHz tone	–	96	–	dB
ΔV_o	unbalance of output voltages	f _i = 1.0 kHz tone	–	0.1	0.4	dB
IEC 958 input						
V _{i(p-p)}	AC input voltage (peak-to-peak value)		0.2	0.5	3.3	V
R _i	input resistance		–	6	–	k Ω
V _{hys}	hysteresis voltage		–	40	–	mV

Notes

1. All supply pins V_{DD} and V_{SS} must be connected to the same external power supply unit.
2. When the DAC must drive a higher capacitive load (above 50 pF), a series resistor of 100 Ω must be used to prevent oscillations in the output stage of the operational amplifier.

96 kHz IEC 958 audio DAC

UDA1351TS

12 TIMING CHARACTERISTICS

$V_{DD} = V_{DDA} = 2.7$ to 3.6 V; $T_{amb} = -40$ to $+85$ °C; $R_L = 5$ k Ω ; all voltages measured with respect to ground; unless otherwise specified.

SYMBOL	PARAMETER	CONDITIONS	MIN.	TYP.	UNIT
Device reset					
t_{rst}	reset active time		–	250	μ s
PLL lock time					
t_{lock}	time to lock	$f_s = 32.0$ kHz	–	85.0	ms
		$f_s = 44.1$ kHz	–	63.0	ms
		$f_s = 48.0$ kHz	–	60.0	ms
		$f_s = 48.0$ kHz	–	40.0	ms
Microcontroller L3 interface timing (see Figs 8 and 9)					
$T_{cy(CLK)(L3)}$	L3CLOCK cycle time		500	–	ns
$t_{CLK(L3)H}$	L3CLOCK HIGH time		250	–	ns
$t_{CLK(L3)L}$	L3CLOCK LOW time		250	–	ns
$t_{su(L3)A}$	L3MODE set-up time for address mode		190	–	ns
$t_{h(L3)A}$	L3MODE hold time for address mode		190	–	ns
$t_{su(L3)D}$	L3MODE set-up time for data transfer mode		190	–	ns
$t_{h(L3)D}$	L3MODE hold time for data transfer mode		190	–	ns
$t_{(stp)(L3)}$	L3MODE stop time in data transfer mode		190	–	ns
$t_{su(L3)DA}$	L3DATA set-up time in address and data transfer mode		190	–	ns
$t_{h(L3)DA}$	L3DATA hold time in address and data transfer mode		30	–	ns
$t_{su(L3)R}$	L3DATA set-up time in data transfer mode	read mode	50	–	–
$t_{h(L3)R}$	L3DATA hold time in data transfer mode	read mode	360	–	–

96 kHz IEC 958 audio DAC

UDA1351TS

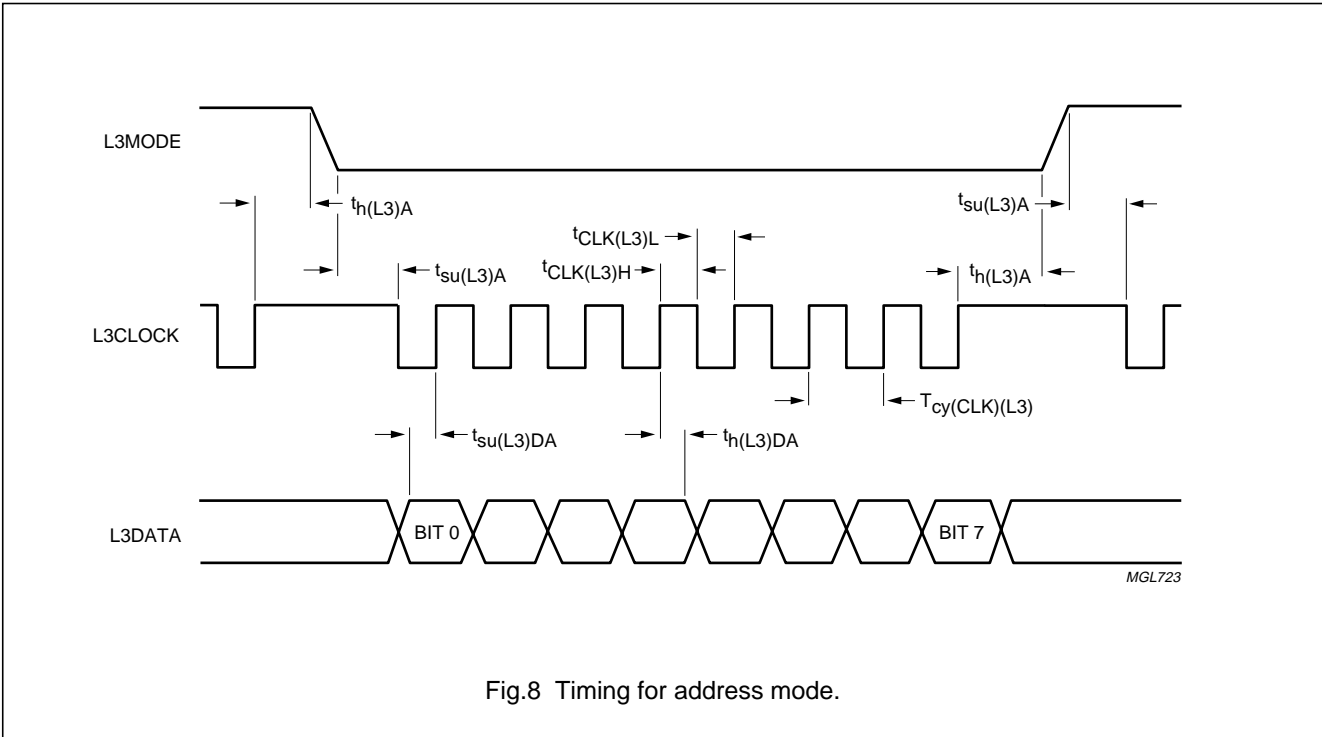

Fig.8 Timing for address mode.

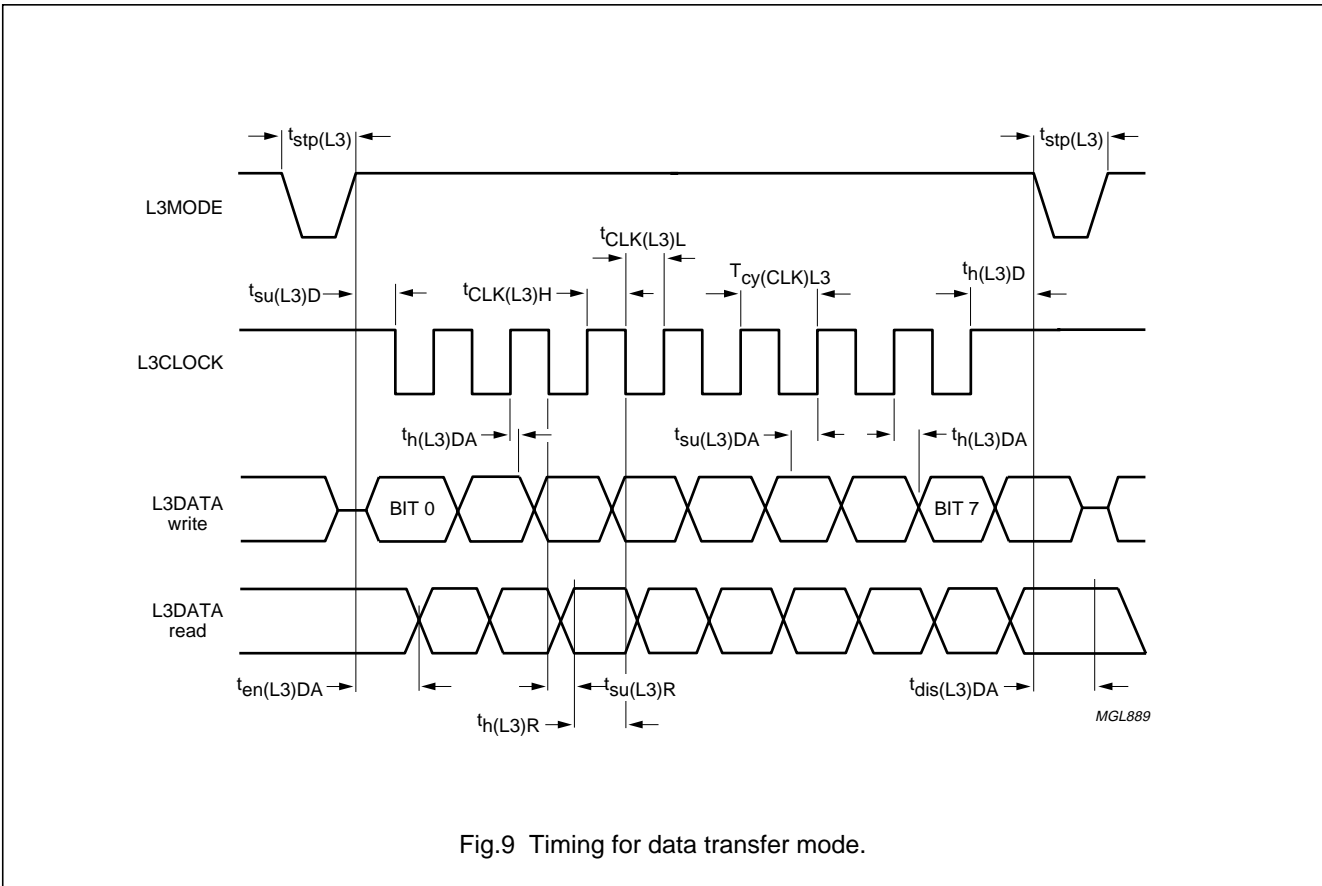

Fig.9 Timing for data transfer mode.

96 kHz IEC 958 audio DAC

UDA1351TS

14 PACKAGE OUTLINE

SSOP28: plastic shrink small outline package; 28 leads; body width 5.3 mm

SOT341-1

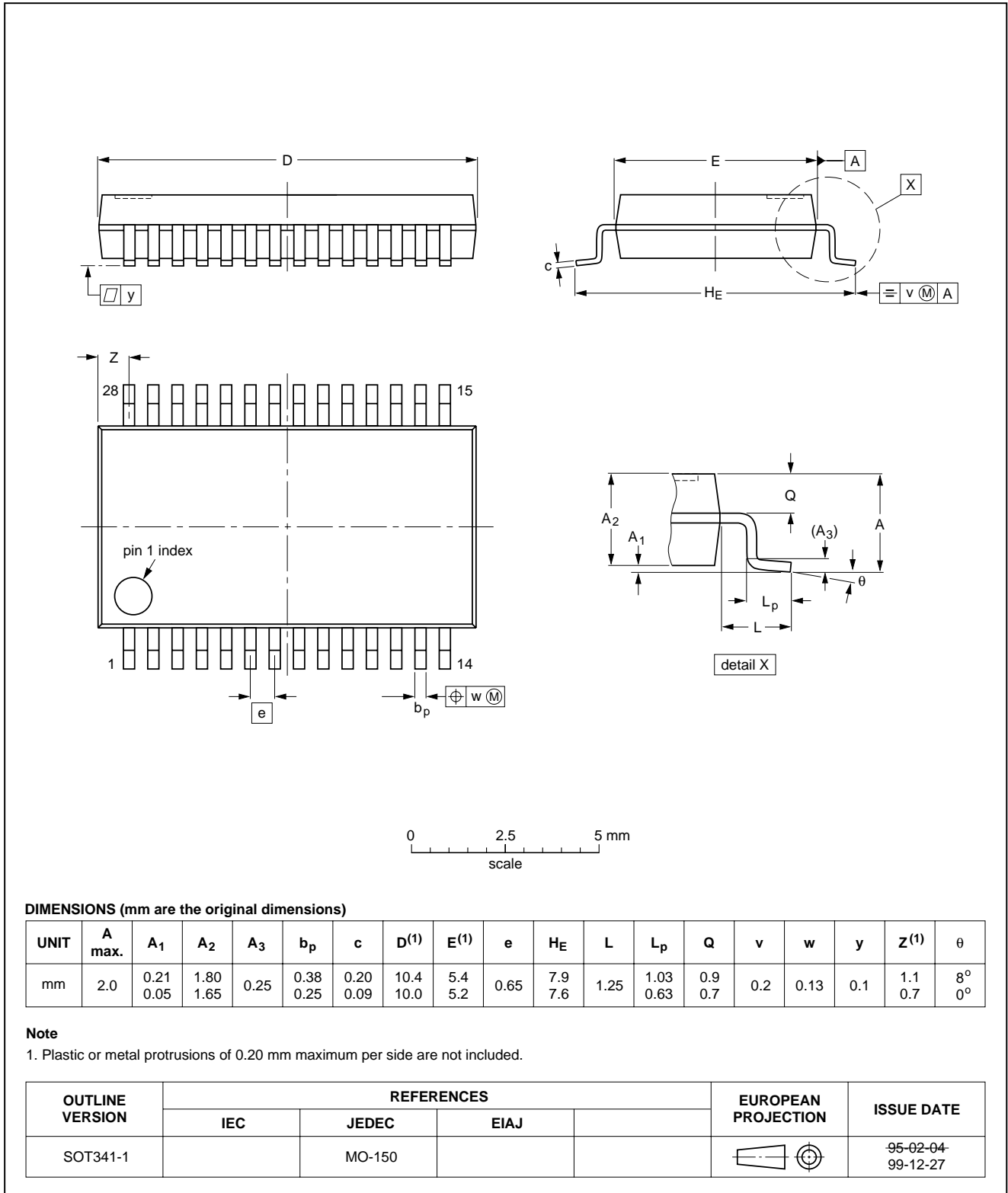

96 kHz IEC 958 audio DAC

UDA1351TS

15 SOLDERING**15.1 Introduction to soldering surface mount packages**

This text gives a very brief insight to a complex technology. A more in-depth account of soldering ICs can be found in our *"Data Handbook IC26; Integrated Circuit Packages"* (document order number 9398 652 90011).

There is no soldering method that is ideal for all surface mount IC packages. Wave soldering is not always suitable for surface mount ICs, or for printed-circuit boards with high population densities. In these situations reflow soldering is often used.

15.2 Reflow soldering

Reflow soldering requires solder paste (a suspension of fine solder particles, flux and binding agent) to be applied to the printed-circuit board by screen printing, stencilling or pressure-syringe dispensing before package placement.

Several methods exist for reflowing; for example, infrared/convection heating in a conveyor type oven. Throughput times (preheating, soldering and cooling) vary between 100 and 200 seconds depending on heating method.

Typical reflow peak temperatures range from 215 to 250 °C. The top-surface temperature of the packages should preferably be kept below 230 °C.

15.3 Wave soldering

Conventional single wave soldering is not recommended for surface mount devices (SMDs) or printed-circuit boards with a high component density, as solder bridging and non-wetting can present major problems.

To overcome these problems the double-wave soldering method was specifically developed.

If wave soldering is used the following conditions must be observed for optimal results:

- Use a double-wave soldering method comprising a turbulent wave with high upward pressure followed by a smooth laminar wave.
- For packages with leads on two sides and a pitch (e):
 - larger than or equal to 1.27 mm, the footprint longitudinal axis is **preferred** to be parallel to the transport direction of the printed-circuit board;
 - smaller than 1.27 mm, the footprint longitudinal axis **must** be parallel to the transport direction of the printed-circuit board.

The footprint must incorporate solder thieves at the downstream end.

- For packages with leads on four sides, the footprint must be placed at a 45° angle to the transport direction of the printed-circuit board. The footprint must incorporate solder thieves downstream and at the side corners.

During placement and before soldering, the package must be fixed with a droplet of adhesive. The adhesive can be applied by screen printing, pin transfer or syringe dispensing. The package can be soldered after the adhesive is cured.

Typical dwell time is 4 seconds at 250 °C.

A mildly-activated flux will eliminate the need for removal of corrosive residues in most applications.

15.4 Manual soldering

Fix the component by first soldering two diagonally-opposite end leads. Use a low voltage (24 V or less) soldering iron applied to the flat part of the lead. Contact time must be limited to 10 seconds at up to 300 °C.

When using a dedicated tool, all other leads can be soldered in one operation within 2 to 5 seconds between 270 and 320 °C.

96 kHz IEC 958 audio DAC

UDA1351TS

15.5 Suitability of surface mount IC packages for wave and reflow soldering methods

PACKAGE	SOLDERING METHOD	
	WAVE	REFLOW ⁽¹⁾
BGA, LFBGA, SQFP, TFBGA	not suitable	suitable
HBCC, HLQFP, HSQFP, HSOP, HTQFP, HTSSOP, SMS	not suitable ⁽²⁾	suitable
PLCC ⁽³⁾ , SO, SOJ	suitable	suitable
LQFP, QFP, TQFP	not recommended ⁽³⁾⁽⁴⁾	suitable
SSOP, TSSOP, VSO	not recommended ⁽⁵⁾	suitable

Notes

1. All surface mount (SMD) packages are moisture sensitive. Depending upon the moisture content, the maximum temperature (with respect to time) and body size of the package, there is a risk that internal or external package cracks may occur due to vaporization of the moisture in them (the so called popcorn effect). For details, refer to the Drypack information in the *“Data Handbook IC26; Integrated Circuit Packages; Section: Packing Methods”*.
2. These packages are not suitable for wave soldering as a solder joint between the printed-circuit board and heatsink (at bottom version) can not be achieved, and as solder may stick to the heatsink (on top version).
3. If wave soldering is considered, then the package must be placed at a 45° angle to the solder wave direction. The package footprint must incorporate solder thieves downstream and at the side corners.
4. Wave soldering is only suitable for LQFP, TQFP and QFP packages with a pitch (e) equal to or larger than 0.8 mm; it is definitely not suitable for packages with a pitch (e) equal to or smaller than 0.65 mm.
5. Wave soldering is only suitable for SSOP and TSSOP packages with a pitch (e) equal to or larger than 0.65 mm; it is definitely not suitable for packages with a pitch (e) equal to or smaller than 0.5 mm.

96 kHz IEC 958 audio DAC

UDA1351TS

16 DATA SHEET STATUS

DATA SHEET STATUS	PRODUCT STATUS	DEFINITIONS ⁽¹⁾
Objective specification	Development	This data sheet contains the design target or goal specifications for product development. Specification may change in any manner without notice.
Preliminary specification	Qualification	This data sheet contains preliminary data, and supplementary data will be published at a later date. Philips Semiconductors reserves the right to make changes at any time without notice in order to improve design and supply the best possible product.
Product specification	Production	This data sheet contains final specifications. Philips Semiconductors reserves the right to make changes at any time without notice in order to improve design and supply the best possible product.

Note

1. Please consult the most recently issued data sheet before initiating or completing a design.

17 DEFINITIONS

Short-form specification — The data in a short-form specification is extracted from a full data sheet with the same type number and title. For detailed information see the relevant data sheet or data handbook.

Limiting values definition — Limiting values given are in accordance with the Absolute Maximum Rating System (IEC 60134). Stress above one or more of the limiting values may cause permanent damage to the device. These are stress ratings only and operation of the device at these or at any other conditions above those given in the Characteristics sections of the specification is not implied. Exposure to limiting values for extended periods may affect device reliability.

Application information — Applications that are described herein for any of these products are for illustrative purposes only. Philips Semiconductors make no representation or warranty that such applications will be suitable for the specified use without further testing or modification.

18 DISCLAIMERS

Life support applications — These products are not designed for use in life support appliances, devices, or systems where malfunction of these products can reasonably be expected to result in personal injury. Philips Semiconductors customers using or selling these products for use in such applications do so at their own risk and agree to fully indemnify Philips Semiconductors for any damages resulting from such application.

Right to make changes — Philips Semiconductors reserves the right to make changes, without notice, in the products, including circuits, standard cells, and/or software, described or contained herein in order to improve design and/or performance. Philips Semiconductors assumes no responsibility or liability for the use of any of these products, conveys no licence or title under any patent, copyright, or mask work right to these products, and makes no representations or warranties that these products are free from patent, copyright, or mask work right infringement, unless otherwise specified.

96 kHz IEC 958 audio DAC

UDA1351TS

NOTES

96 kHz IEC 958 audio DAC

UDA1351TS

NOTES

Philips Semiconductors – a worldwide company

Argentina: see South America

Australia: 3 Figtree Drive, HOMEBUSH, NSW 2140,
Tel. +61 2 9704 8141, Fax. +61 2 9704 8139

Austria: Computerstr. 6, A-1101 WIEN, P.O. Box 213,
Tel. +43 1 60 101 1248, Fax. +43 1 60 101 1210

Belarus: Hotel Minsk Business Center, Bld. 3, r. 1211, Volodarski Str. 6,
220050 MINSK, Tel. +375 172 20 0733, Fax. +375 172 20 0773

Belgium: see The Netherlands

Brazil: see South America

Bulgaria: Philips Bulgaria Ltd., Energoproject, 15th floor,
51 James Bourchier Blvd., 1407 SOFIA,
Tel. +359 2 68 9211, Fax. +359 2 68 9102

Canada: PHILIPS SEMICONDUCTORS/COMPONENTS,
Tel. +1 800 234 7381, Fax. +1 800 943 0087

China/Hong Kong: 501 Hong Kong Industrial Technology Centre,
72 Tat Chee Avenue, Kowloon Tong, HONG KONG,
Tel. +852 2319 7888, Fax. +852 2319 7700

Colombia: see South America

Czech Republic: see Austria

Denmark: Sydhavnsgade 23, 1780 COPENHAGEN V,
Tel. +45 33 29 3333, Fax. +45 33 29 3905

Finland: Sinikalliontie 3, FIN-02630 ESPOO,
Tel. +358 9 615 800, Fax. +358 9 6158 0920

France: 51 Rue Carnot, BP317, 92156 SURESNES Cedex,
Tel. +33 1 4099 6161, Fax. +33 1 4099 6427

Germany: Hammerbrookstraße 69, D-20097 HAMBURG,
Tel. +49 40 2353 60, Fax. +49 40 2353 6300

Hungary: Philips Hungary Ltd., H-1119 Budapest, Fehervari ut 84/A,
Tel: +36 1 382 1700, Fax: +36 1 382 1800

India: Philips INDIA Ltd, Band Box Building, 2nd floor,
254-D, Dr. Annie Besant Road, Worli, MUMBAI 400 025,
Tel. +91 22 493 8541, Fax. +91 22 493 0966

Indonesia: PT Philips Development Corporation, Semiconductors Division,
Gedung Philips, Jl. Buncit Raya Kav.99-100, JAKARTA 12510,
Tel. +62 21 794 0040 ext. 2501, Fax. +62 21 794 0080

Ireland: Newstead, Clonskeagh, DUBLIN 14,
Tel. +353 1 7640 000, Fax. +353 1 7640 200

Israel: RAPAC Electronics, 7 Kehilat Saloniki St, PO Box 18053,
TEL AVIV 61180, Tel. +972 3 645 0444, Fax. +972 3 649 1007

Italy: PHILIPS SEMICONDUCTORS, Via Casati, 23 - 20052 MONZA (MI),
Tel. +39 039 203 6838, Fax +39 039 203 6800

Japan: Philips Bldg 13-37, Kohnan 2-chome, Minato-ku,
TOKYO 108-8507, Tel. +81 3 3740 5130, Fax. +81 3 3740 5057

Korea: Philips House, 260-199 Itaewon-dong, Yongsan-ku, SEOUL,
Tel. +82 2 709 1412, Fax. +82 2 709 1415

Malaysia: No. 76 Jalan Universiti, 46200 PETALING JAYA, SELANGOR,
Tel. +60 3 750 5214, Fax. +60 3 757 4880

Mexico: 5900 Gateway East, Suite 200, EL PASO, TEXAS 79905,
Tel. +9-5 800 234 7381, Fax +9-5 800 943 0087

Middle East: see Italy

Netherlands: Postbus 90050, 5600 PB EINDHOVEN, Bldg. VB,
Tel. +31 40 27 82785, Fax. +31 40 27 88399

New Zealand: 2 Wagener Place, C.P.O. Box 1041, AUCKLAND,
Tel. +64 9 849 4160, Fax. +64 9 849 7811

Norway: Box 1, Manglerud 0612, OSLO,
Tel. +47 22 74 8000, Fax. +47 22 74 8341

Pakistan: see Singapore

Philippines: Philips Semiconductors Philippines Inc.,
106 Valero St. Salcedo Village, P.O. Box 2108 MCC, MAKATI,
Metro MANILA, Tel. +63 2 816 6380, Fax. +63 2 817 3474

Poland: Al.Jerozolimskie 195 B, 02-222 WARSAW,
Tel. +48 22 5710 000, Fax. +48 22 5710 001

Portugal: see Spain

Romania: see Italy

Russia: Philips Russia, Ul. Usatcheva 35A, 119048 MOSCOW,
Tel. +7 095 755 6918, Fax. +7 095 755 6919

Singapore: Lorong 1, Toa Payoh, SINGAPORE 319762,
Tel. +65 350 2538, Fax. +65 251 6500

Slovakia: see Austria

Slovenia: see Italy

South Africa: S.A. PHILIPS Pty Ltd., 195-215 Main Road Martindale,
2092 JOHANNESBURG, P.O. Box 58088 Newville 2114,
Tel. +27 11 471 5401, Fax. +27 11 471 5398

South America: Al. Vicente Pinzon, 173, 6th floor,
04547-130 SÃO PAULO, SP, Brazil,
Tel. +55 11 821 2333, Fax. +55 11 821 2382

Spain: Balmes 22, 08007 BARCELONA,
Tel. +34 93 301 6312, Fax. +34 93 301 4107

Sweden: Kottbygatan 7, Akalla, S-16485 STOCKHOLM,
Tel. +46 8 5985 2000, Fax. +46 8 5985 2745

Switzerland: Allmendstrasse 140, CH-8027 ZÜRICH,
Tel. +41 1 488 2741 Fax. +41 1 488 3263

Taiwan: Philips Semiconductors, 5F, No. 96, Chien Kuo N. Rd., Sec. 1,
TAIPEI, Taiwan Tel. +886 2 2134 2451, Fax. +886 2 2134 2874

Thailand: PHILIPS ELECTRONICS (THAILAND) Ltd.,
60/14 MOO 11, Bangna Trad Road KM. 3, Bagna, BANGKOK 10260,
Tel. +66 2 361 7910, Fax. +66 2 398 3447

Turkey: Yukari Dudullu, Org. San. Blg., 2.Cad. Nr. 28 81260 Umraniye,
ISTANBUL, Tel. +90 216 522 1500, Fax. +90 216 522 1813

Ukraine: PHILIPS UKRAINE, 4 Patrice Lumumba str., Building B, Floor 7,
252042 KIEV, Tel. +380 44 264 2776, Fax. +380 44 268 0461

United Kingdom: Philips Semiconductors Ltd., 276 Bath Road, Hayes,
MIDDLESEX UB3 5BX, Tel. +44 208 730 5000, Fax. +44 208 754 8421

United States: 811 East Arques Avenue, SUNNYVALE, CA 94088-3409,
Tel. +1 800 234 7381, Fax. +1 800 943 0087

Uruguay: see South America

Vietnam: see Singapore

Yugoslavia: PHILIPS, Trg N. Pasica 5/v, 11000 BEOGRAD,
Tel. +381 11 3341 299, Fax.+381 11 3342 553

For all other countries apply to: Philips Semiconductors,
Marketing Communications, Building BE-p, P.O. Box 218, 5600 MD EINDHOVEN,
The Netherlands, Fax. +31 40 27 24825

Internet: <http://www.semiconductors.philips.com>

© Philips Electronics N.V. 2001

SCA 71

All rights are reserved. Reproduction in whole or in part is prohibited without the prior written consent of the copyright owner.

The information presented in this document does not form part of any quotation or contract, is believed to be accurate and reliable and may be changed without notice. No liability will be accepted by the publisher for any consequence of its use. Publication thereof does not convey nor imply any license under patent- or other industrial or intellectual property rights.

Printed in The Netherlands

753503/02/pp32

Date of release: 2001 Feb 05

Document order number: 9397 750 07921

Let's make things better.

Philips
Semiconductors



PHILIPS

Mouser Electronics

Authorized Distributor

Click to View Pricing, Inventory, Delivery & Lifecycle Information:

[NXP:](#)

[UDA1351TS/N1,518](#)