

# bq50002 适用于 WPC V 1.2 A11 发送器的 低成本 5V 无线电源发送器模拟前端

## 1 特性

- 符合无线充电联盟 (WPC) V1.2 A11 低功耗发送器规范的 5V 发送器模拟前端 (AFE)
- 专为与 bq500511 WPC 控制器搭配使用而设计
- 适用于 WPC 和 5V 专用无线电源发送器
- 支持 5W 的接收器输出功率
- 在无线电源发送器中集成了所需的全部模拟功能
  - 金属氧化物半导体场效应晶体管 (MOSFET) 驱动器和同步 N 沟道功率场效应晶体管 (FET)
  - 精确的电流感测
  - 变频振荡器
  - 高效稳压器
  - 用于对接收器信号进行解码的高灵敏度解调器
- 双芯片解决方案实现了效率超过 75% 的高效发送器设计
- 超低待机功耗, 即使在数字 Ping 过程中也可实现 (< 30mW)
- 动态电源限制 (DPL)<sup>TM</sup> 通过功率受限的输入源实现正常运行
- 系统发光二极管 (LED) 指示充电状态和故障状态
- 精准的外来物体检测 (FOD) 方法

## 2 应用

- 适用于智能手机和可穿戴应用且符合 WPC 标准的无线发送器
- 专用无线充电器和发送器
- 医疗和可穿戴应用

## 3 说明

bq50002 是一款高度集成的无线电源发送器模拟前端, 其中包含实现符合 WPC 标准的 5V 发送器所需的全部模拟组件。bq50002 将全桥电源驱动器与 MOSFET、变频振荡器、双通道通信解调器、线性稳压器以及保护电路相集成。为实现紧凑型双芯片无线电源发送器解决方案, bq50002 必须与数字控制器 bq500511 搭配使用。bq500511 可安全接合 Rx 器件、接收充电器传输的通信数据包以及根据 WPC v1.2 规范管理功率传输。

该系统支持外来物体检测 (FOD), 具体方法是通过持续监视传输功率并将功率值与接收器报告的接收功率相比较。该功能可防止因在无线电源传输场中错误放置金属物体而产生功率损耗。为此, bq50002 使用电流感测放大器对输入直流电流进行高精度测量。如果在功率传输过程中出现任何异常情况, bq500511 会对其进行处理并提供指示输出。综合状态和故障监视特性可实现一个经 WPC 认证的低成本、稳健耐用的无线电源系统设计。

bq50002 采用 5.00mm × 5.00mm 32 引脚散热增强型四方扁平无引线 (QFN) 封装。

### 器件信息 (1)

部件号	封装	封装尺寸 (标称值)
bq50002	QFN (32)	5.00mm x 5.00mm

(1) 要了解所有可用封装, 请见数据表末尾的可订购产品附录。

简化电路原理图

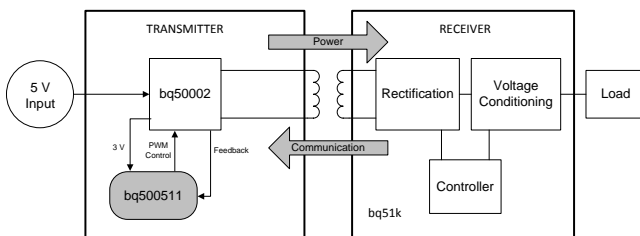

效率与 电源间的关系

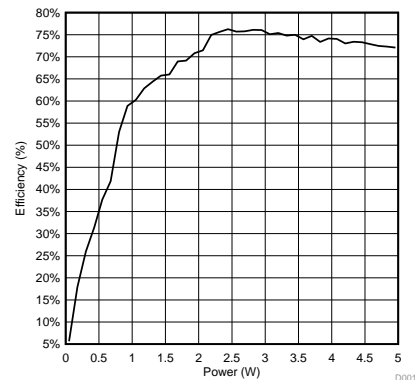

## 目录

<p><b>1</b> 特性 ..... 1</p> <p><b>2</b> 应用 ..... 1</p> <p><b>3</b> 说明 ..... 1</p> <p><b>4</b> 修订历史记录 ..... 2</p> <p><b>5</b> <b>Pin Configuration and Functions</b> ..... 3</p> <p><b>6</b> <b>Specifications</b> ..... 5</p> <p>    6.1 Absolute Maximum Ratings ..... 5</p> <p>    6.2 ESD Ratings ..... 5</p> <p>    6.3 Recommended Operating Conditions ..... 5</p> <p>    6.4 Thermal Information ..... 6</p> <p>    6.5 Electrical Characteristics ..... 6</p> <p>    6.6 Typical Characteristics ..... 7</p> <p><b>7</b> <b>Detailed Description</b> ..... 8</p> <p>    7.1 Overview ..... 8</p> <p>    7.2 Functional Block Diagram ..... 8</p> <p>    7.3 Feature Description ..... 9</p>	<p>    7.4 Device Functional Modes ..... 12</p> <p><b>8</b> <b>Application and Implementation</b> ..... 14</p> <p>    8.1 Application Information ..... 14</p> <p>    8.2 Typical Application ..... 15</p> <p><b>9</b> <b>Power Supply Recommendations</b> ..... 19</p> <p><b>10</b> <b>Layout</b> ..... 19</p> <p>    10.1 Layout Guidelines ..... 19</p> <p>    10.2 Layout Examples ..... 20</p> <p><b>11</b> 器件和文档支持 ..... 23</p> <p>    11.1 文档支持 ..... 23</p> <p>    11.2 社区资源 ..... 23</p> <p>    11.3 商标 ..... 23</p> <p>    11.4 静电放电警告 ..... 23</p> <p>    11.5 Glossary ..... 23</p> <p><b>12</b> 机械、封装和可订购信息 ..... 24</p>
----------------------------------------------------------------------------------------------------------------------------------------------------------------------------------------------------------------------------------------------------------------------------------------------------------------------------------------------------------------------------------------------------------------------------------------------------------------------------------------------------------------------------------------------------------------------------------------------------------------------------------------------------------------------------------------------------	---------------------------------------------------------------------------------------------------------------------------------------------------------------------------------------------------------------------------------------------------------------------------------------------------------------------------------------------------------------------------------------------------------------------------------------------------------------------------------------------------------------------------------------------------------------------------------------------------------------------------------------

## 4 修订历史记录

### Changes from Original (October 2015) to Revision A

**Page**

<ul style="list-style-type: none"> <li>• 已更改 销售状态“产品预览”至“最终产品”。 ..... 1</li> </ul>	1
------------------------------------------------------------------------------------	---

## 5 Pin Configuration and Functions

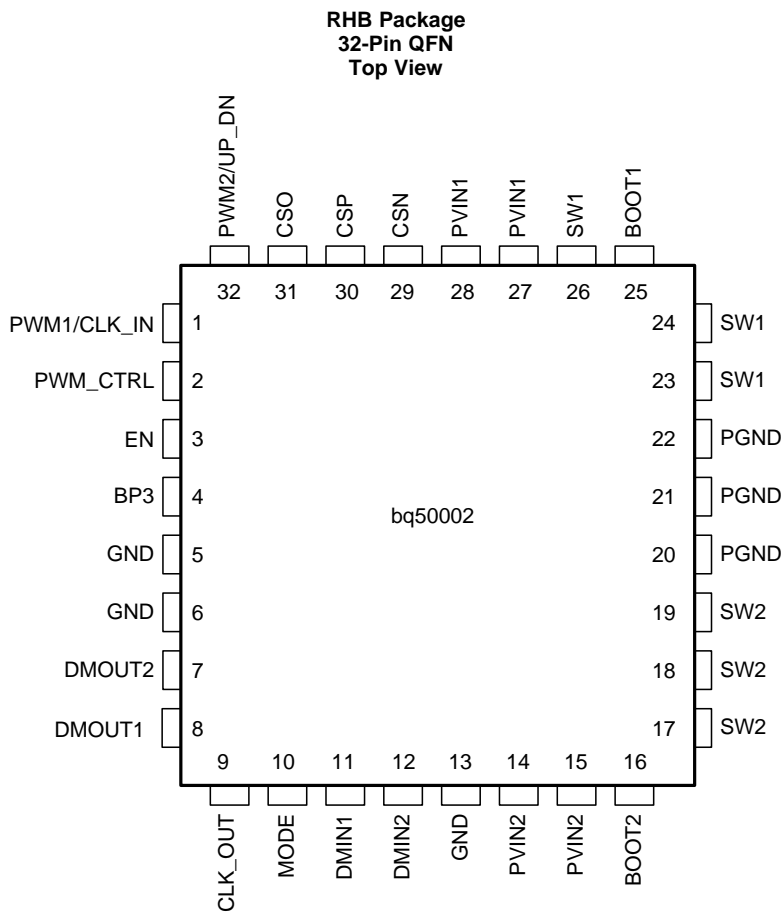

### Pin Functions

PIN		I/O	DESCRIPTION
NAME	NO.		
BOOT1	25	I/O	Positive supply rail for the high-side gate driver. Connect a 0.1- $\mu$ F ceramic capacitor between the BOOT1 and SW1 pins.
BOOT2	16	I/O	Positive supply rail for the high-side gate driver. Connect a 0.1- $\mu$ F ceramic capacitor between the BOOT2 and SW2 pins.
BP3	4	O	LDO output. Tie with 2.2- $\mu$ F capacitor to GND. For use by bq500511 only.
CLK_OUT	9	O	Internal oscillator clock out signal.
CSN	29	I	Current sense amplifier negative input.
CSO	31	O	Current sense amplifier output. For use by bq500511 only.
CSP	30	I	Current sense amplifier positive input. Connect current sense resistor as close as possible to this pin. This also serves as the quiet node for power supply input.
DMIN1	11	I	Modulated signal from coil for DEMOD CHAN1.
DMIN2	12	I	Modulated signal from coil for DEMOD CHAN2.
DMOUT1	8	O	Demodulated 2-kHz signal from CHAN1. For use by bq500511 only.
DMOUT2	7	O	Demodulated 2-kHz signal from CHAN2. For use by bq500511 only.
EN	3	I	Enable pin with a weak internal pull-down. Float or pull below 1.5 V to disable gate driver, demodulation and current sense. Pull above 2.2 V to enable gate driver. Used by bq500511 to enter and leave standby mode for the transmitter.
GND	5	–	Signal ground for the ground-referenced logic. All signal level circuits should be referenced to this pin unless otherwise noted.
GND	6	–	Signal ground for the ground-referenced logic. All signal level circuits should be referenced to this pin unless otherwise noted.
GND	13	–	Signal ground for the ground-referenced logic. All signal level circuits should be referenced to this pin unless otherwise noted.
MODE	10	I	MODE pin with a weak internal pull-down. Float, or pull below 1.5 V to enable frequency control of the internally generated PWM signal. Pull above 2.2 V to enable pulse width control of the internally generated PWM signal. Used by bq500511 to select the control method for power control
PGND	20	–	Power ground for the ground-referenced power stage. Connect to GND.
PGND	21	–	Power ground for the ground-referenced power stage. Connect to GND.
PGND	22	–	Power ground for the ground-referenced power stage. Connect to GND.
PVIN1	27	I	DC input voltage for half-bridge MOSFET. Bypass with 22- $\mu$ F ceramic capacitor to GND.
PVIN1	28	I	DC input voltage for half-bridge MOSFET. Bypass with 22- $\mu$ F ceramic capacitor to GND.
PVIN2	14	I	DC input voltage for half-bridge MOSFET. Bypass with 22- $\mu$ F ceramic capacitor to GND.
PVIN2	15	I	DC input voltage for half-bridge MOSFET. Bypass with 22- $\mu$ F ceramic capacitor to GND.
PWM_CTRL	2	I	PWM_CTRL pin with a weak internal pull-down. Controlled by bq500511 (SLUSCD3) for system power delivery control.
PWM1/CLK_IN	1	I	PWM1/CLK_IN pin with a weak internal pull-down. Controlled by bq500511 (SLUSCD3) for system power delivery control.
PWM2/UP_DN	32	I	PWM2/UP_DN pin with a weak internal pull-down. Controlled by bq500511 (SLUSCD3) for system power delivery control.
SW1	23	O	Switch node of the half-bridge MOSFETs. Connect to TX coil.
SW1	24	O	Switch node of the half-bridge MOSFETs. Connect to TX coil.
SW1	26	O	Switch node of the half-bridge MOSFETs. Connect to TX coil.
SW2	17	O	Switch node of the half-bridge MOSFETs. Connect to resonant capacitor.
SW2	18	O	Switch node of the half-bridge MOSFETs. Connect to resonant capacitor.
SW2	19	O	Switch node of the half-bridge MOSFETs. Connect to resonant capacitor.

## 6 Specifications

### 6.1 Absolute Maximum Ratings

over operating free-air temperature range (unless otherwise noted) <sup>(1)</sup>

	MIN	MAX	UNIT
PVIN1, PVIN2	-0.3	7	V
BOOT1 <sup>(2)</sup>	-0.3	14	V
VBOOT1 – VSW1	-0.3	7	V
BOOT2 <sup>(2)</sup>	-0.3	14	V
VBOOT2 – VSW2	-0.3	7	V
PWM1, PWM2, EN, CLK_OUT, MODE, PWM_CTRL	-0.3	3.6	V
DMIN1	-5	7	V
DMIN2	-0.3	7	V
CSN, CSP	-0.3	7	V
CSN to CSP	-0.5	0.5	V
Operating junction temperature, T <sub>J</sub>	-40	125	°C
Storage temperature, T <sub>stg</sub>	-55	150	°C

- (1) Stresses beyond those listed under *Absolute Maximum Ratings* may cause permanent damage to the device. These are stress ratings only, which do not imply functional operation of the device at these or any other conditions beyond those indicated under *Recommended Operating Conditions*. Exposure to absolute-maximum-rated conditions for extended periods may affect device reliability.
- (2) In normal use, BOOT1, BOOT2 voltage internally regulated.

### 6.2 ESD Ratings

		VALUE	UNIT
V <sub>(ESD)</sub> Electrostatic discharge	Human-body model (HBM), per ANSI/ESDA/JEDEC JS-001 <sup>(1)</sup>	±1000	V
	Charged-device model (CDM), per JEDEC specification JESD22-C101 <sup>(2)</sup>	±500	V

- (1) JEDEC document JEP155 states that 500-V HBM allows safe manufacturing with a standard ESD control process.
- (2) JEDEC document JEP157 states that 250-V CDM allows safe manufacturing with a standard ESD control process.

### 6.3 Recommended Operating Conditions

over operating free-air temperature range (unless otherwise noted)

		MIN	NOM	MAX	UNIT
PVIN1, PVIN2		4.5	5	5.5	V
PWM1, PWM2, EN, CLK_OUT, MODE, PWM_CTRL		0	3	3.3	V
DMIN1		-0.3		5	V
DMIN2		-0.3		5	V
C <sub>BP3</sub>	BP3 ceramic capacitor		2.2		μF
C <sub>PVIN1</sub> , C <sub>PVIN2</sub>	PVIN1, PVIN2 ceramic capacitor		0.1		μF
C <sub>PVIN1</sub> , C <sub>PVIN2</sub>	PVIN1, PVIN2 electrolytic capacitor		22		μF
C <sub>BOOT1</sub> , C <sub>BOOT2</sub>	SW1-BOOT1, SW2-BOOT2 capacitor		0.1		μF

## 6.4 Thermal Information

THERMAL METRIC <sup>(1)</sup>		bq50002	
		QFN	UNIT
		32 PINS	
R <sub>θJA</sub>	Junction-to-ambient thermal resistance	40.6	°C/W
R <sub>θJC(top)</sub>	Junction-to-case (top) thermal resistance	32.1	°C/W
R <sub>θJB</sub>	Junction-to-board thermal resistance	13.1	°C/W
ψ <sub>JT</sub>	Junction-to-top characterization parameter	0.8	°C/W
ψ <sub>JB</sub>	Junction-to-board characterization parameter	13.0	°C/W
R <sub>θJC(bot)</sub>	Junction-to-case (bottom) thermal resistance	5.7	°C/W

(1) For more information about traditional and new thermal metrics, see the *Semiconductor and IC Package Thermal Metrics* application report, [SPRA953](#).

## 6.5 Electrical Characteristics

–40°C ≤ T<sub>J</sub> ≤ 125°C, V<sub>PVIN1</sub> = 5V, V<sub>PVIN2</sub> = 5 V (unless otherwise noted)

PARAMETER	TEST CONDITIONS	MIN	TYP	MAX	UNIT
<b>INPUT VOLTAGE (VIN)</b>					
UVLO rising threshold	V <sub>IN</sub> rising	3.75	3.90	4.20	V
UVLO falling threshold	V <sub>IN</sub> falling	3.60	3.85	4.08	V
<b>REGULATOR VOLTAGE (BP3)</b>					
BP3 output voltage	I <sub>BP3</sub> = –5 mA, V <sub>PVIN1</sub> = V <sub>PVIN2</sub> = 5.0 V	2.9	3.0	3.1	V
BP3 output voltage	I <sub>BP3</sub> = –10 mA, V <sub>PVIN1</sub> = V <sub>PVIN2</sub> = 5.0 V	2.9	3.0	3.1	V
BP3 load current max	V <sub>BP3</sub> = 2.7 V, V <sub>PVIN1</sub> = V <sub>PVIN2</sub> = 5.0 V	7.7	14	21	mA
<b>CURRENT SENSE AMPLIFIER (CSP, CSN)</b>					
Current sense amplifier gain	0°C < T <sub>J</sub> < 85°C	49	50	51	V/V
Current sense amplifier offset	0°C < T <sub>J</sub> < 85°C	-14		14	mV
Input current (CSP)	V <sub>CSP</sub> = 5.0 V, V <sub>PVIN1</sub> = V <sub>PVIN2</sub> = 5.0 V		1.5		mA
Input current (CSN)	V <sub>CSN</sub> = 5.0 V, V <sub>PVIN1</sub> = V <sub>PVIN2</sub> = 5.0 V	8.5	10.0	11.3	μA
<b>EN</b>					
High-level input voltage	Input rising	1.7	1.8	1.9	V
Low-level input voltage	Input falling	0.8	1.0	1.1	V
EN pull-down resistance	EN = 3 V	40	50	60	kΩ
<b>PWM_CTRL</b>					
High-level input voltage	Input rising	1.4	1.6	1.8	V
Low-level input voltage	Input falling	0.9	1.0	1.1	V
PWM_CTRL pull-down resistance	PWM_CTRL = 3 V	40	50	60	kΩ

## Electrical Characteristics (continued)

 $-40^{\circ}\text{C} \leq T_J \leq 125^{\circ}\text{C}$ ,  $V_{PVIN1} = 5\text{V}$ ,  $V_{PVIN2} = 5\text{V}$  (unless otherwise noted)

PARAMETER	TEST CONDITIONS	MIN	TYP	MAX	UNIT
<b>PWM1</b>					
High-level input voltage	Input rising	1.6	1.8	1.9	V
Low-level input voltage	Input falling	0.9	1.0	1.1	V
PWM1 pull-down resistance	PWM1 = 3 V	40	50	60	k $\Omega$
<b>PWM2</b>					
High-level input voltage	Input rising	1.6	1.7	1.8	V
Low-level input voltage	Input falling	1.0	1.1	1.2	V
PWM2 pull-down resistance	PWM2 = 3 V	40	50	60	k $\Omega$
<b>MODE</b>					
High-level input voltage	Input rising	1.7	1.8	1.9	V
Low-level input voltage	Input falling	0.9	1.0	1.1	V
MODE pull-down resistance	MODE = 3 V	40	50	60	k $\Omega$
<b>BOOTSTRAP DIODE (BOOT1 AND BOOT2)</b>					
Regulation voltage (BOOT1)	$V_{PVIN1} = V_{PVIN2} = 5\text{V}$ , $I_{BOOT} = 0\text{mA}$	4.2	4.4	4.7	V
Regulation voltage (BOOT2)	$V_{PVIN1} = V_{PVIN2} = 5\text{V}$ , $I_{BOOT} = 0\text{mA}$	4.9	5.0	5.1	V
UVLO (BOOT1)	$V_{PVIN1} = V_{PVIN2} = 5\text{V}$	1.8	2.3	2.7	V
UVLO (BOOT2)	$V_{PVIN1} = V_{PVIN2} = 5\text{V}$	1.8	2.2	2.6	V
<b>MOSFETS (SW1 AND SW2)</b>					
SW1 high-side $R_{DS(on)}$	$V_{PVIN1} = V_{PVIN2} = 5\text{V}$	59	76	107	m $\Omega$
SW1 low-side $R_{DS(on)}$	$V_{PVIN1} = V_{PVIN2} = 5\text{V}$	48	61	86	m $\Omega$
SW2 high-side $R_{DS(on)}$	$V_{PVIN1} = V_{PVIN2} = 5\text{V}$	42	49	64	m $\Omega$
SW2 low-side $R_{DS(on)}$	$V_{PVIN1} = V_{PVIN2} = 5\text{V}$ , $I_{SW} = 500\text{mA}$	39	46	58	m $\Omega$

## 6.6 Typical Characteristics

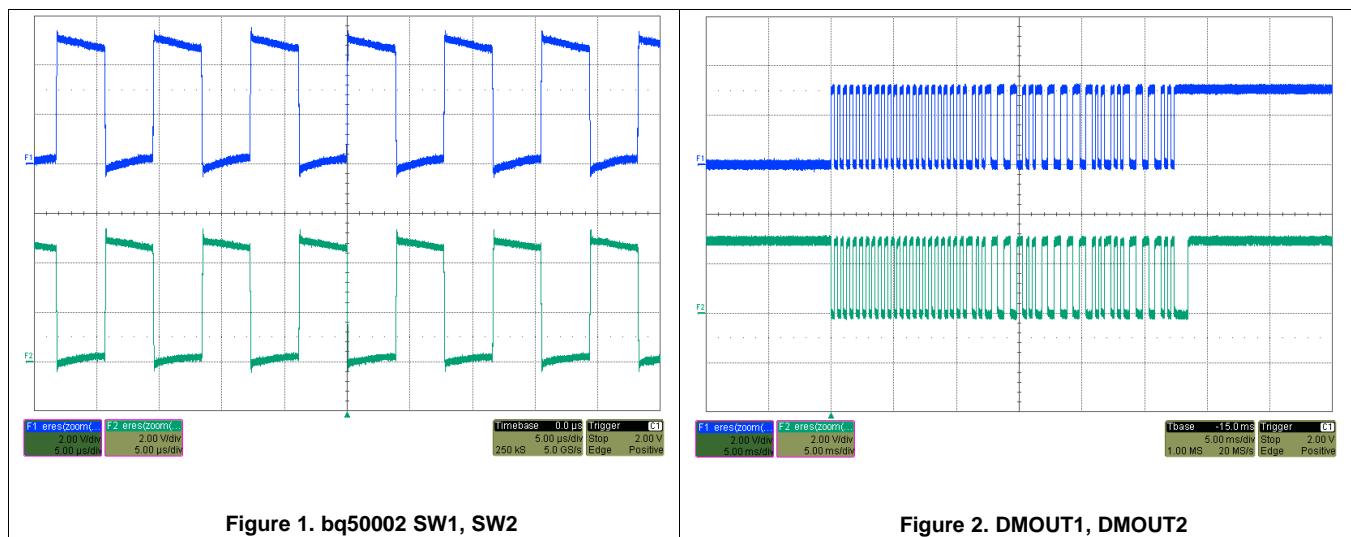

## 7 Detailed Description

### 7.1 Overview

The principle of wireless power transfer is simply an open-cored transformer consisting of transmitter and receiver coils. The transmitter coil and electronics are typically built into a charger pad and the receiver coil and electronics are typically built into a portable device, such as a smart phone. When the receiver coil is positioned on the transmitter coil, magnetic coupling occurs when the transmitter coil is driven. The flux is coupled into the secondary coil, which induces a voltage and current flows. The secondary voltage is rectified, and power can be transferred effectively to a load, wirelessly. Power transfer can be managed through various closed loop control schemes.

After power is applied and the transmitter device comes out of reset, it will automatically begin the process of detecting and powering a receiver. The bq500511 sends a ping to detect the presence of a receiver on the pad. After a receiver is detected, the bq500511 attempts to establish communication and begin power transfer. The bq500511 is designed to operate with the bq50002 Wireless Power Transmitter Analog Front End to control a full-bridge power stage to drive the primary coil. Through a simple interface the bq500511 instructs the bq50002 how much to increase or decrease power. The full bridge power stage allows for higher power delivery for a given supply voltage.

### 7.2 Functional Block Diagram

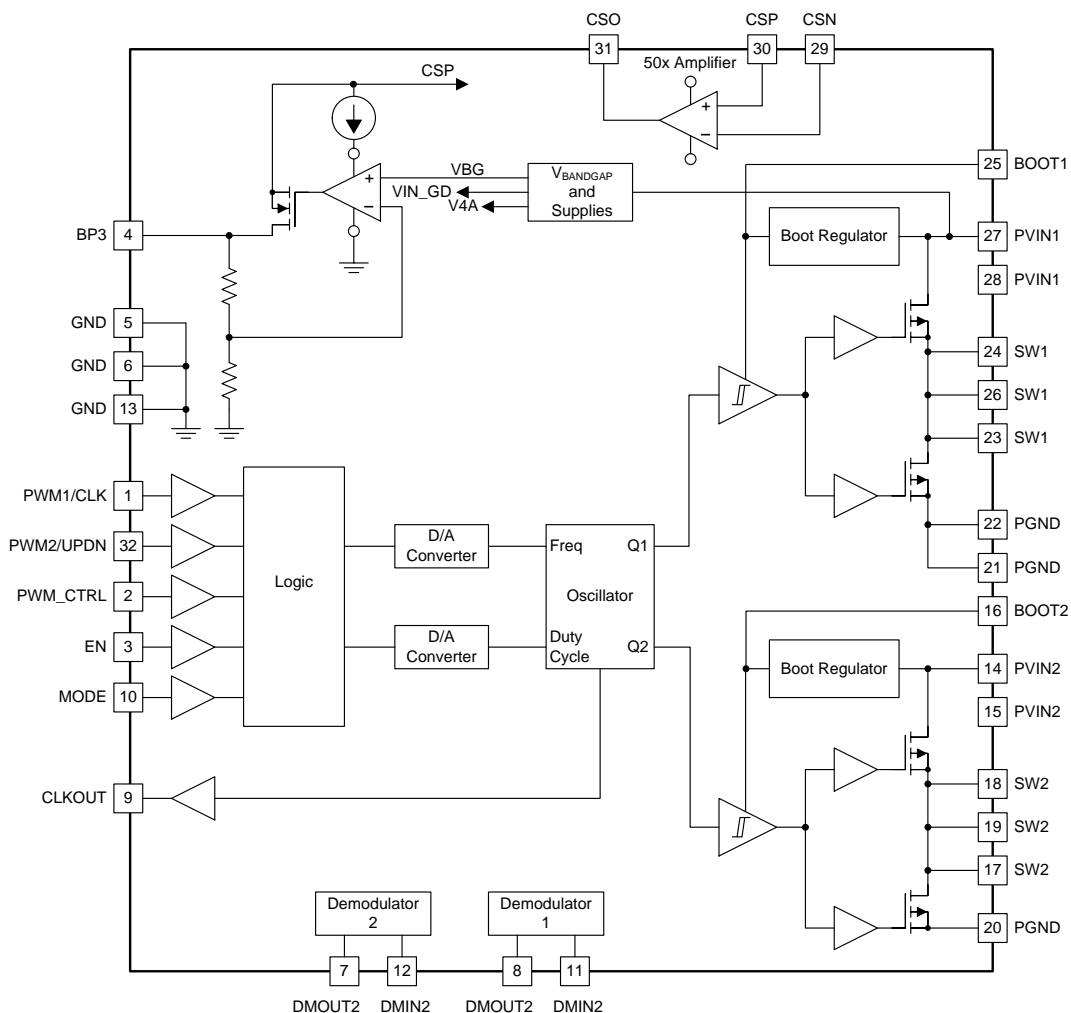



## 7.3 Feature Description

### 7.3.1 Demodulator

The embedded demodulator outputs at least one valid bit stream under all modulation conditions that can be used by the accompanied bq500511 controller in order to comply with WPC specification.

More specifically, the WPC worst case condition is defined as the transmitter operating at the minimum modulation level, and the receiver coil is measured by certain x, y and z axis distance to the center of the transmitter coil.

Analog demodulation channel function diagram:

- The diagram below from the WPC spec document explains the concept of Minimum Modulation. The peak-to-peak amplitude difference in TX coil waveform between HI and LO states is 400 mV. With 20-V<sub>pp</sub> carrier waveform, and 400-mV<sub>pp</sub> modulation, with a typical divider it translates to 1 V<sub>pp</sub> ±20 mV<sub>pp</sub> at the input of the demodulator channel.
- The difference of the amplitude of the primary cell voltage in the HI and LO state is at least 200 mV.

During a transition the primary cell current and primary cell voltages are undefined. See [Figure 3](#).

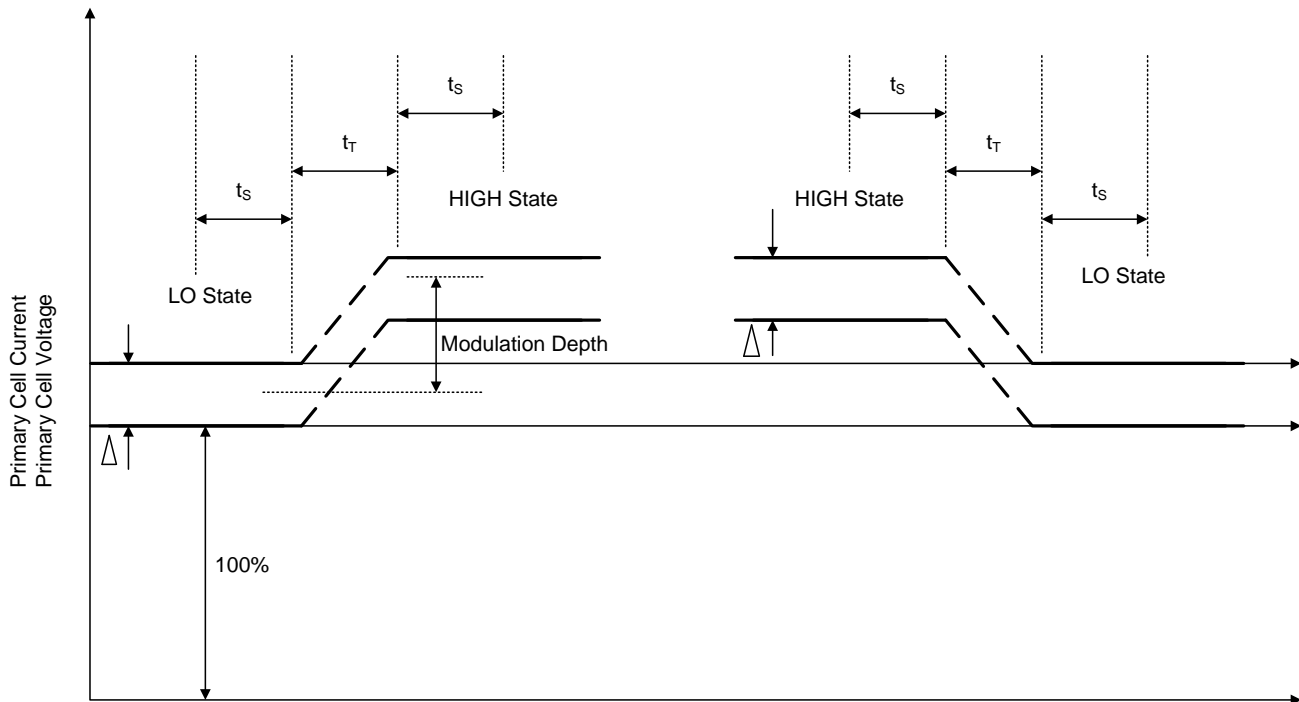

Figure 3. Amplitude Modulation of the Power Signal

## Feature Description (continued)

### 7.3.2 PWM Control

#### 7.3.2.1 PWM\_CTRL Input

bq50002 operates in two modes:

Direct PWM Control Mode and Self Switching. The mode of operation is set by the state of PWM\_CTRL input when EN=HIGH. This is intended for control by bq500511.

#### 7.3.2.2 PWM1, PWM2

bq50002 passes external PWM inputs to drive gate drivers when the following conditions hold:

- EN pin is HIGH
- PWM\_CTRL pin is HIGH
- Typical Dead Time shall be better than 20 ns. Minimum PWM input pulse duration that changes SW output should be less than 50 ns.

#### 7.3.2.3 Self-Switching

bq50002 follows the commands from the controller to adjust the internal oscillator frequency up or down to adjust output power levels when the following conditions apply:

- PWM\_CTRL pin is LOW
- PWM1/CLK\_IN behaves as CLK\_IN pin. The CLK\_IN rising edge triggers frequency increase or decrease by one step based on the state of PWM2/UP\_DN pin.
- Self-switching starts at F=175 kHz when PWM\_CTRL state changes from HIGH to LOW. Operating frequency changes are based on the inputs of UP\_DN, CLK\_IN and MODE.
- The CLK\_OUT pin outputs 3.3V logic level with frequency equal in value to the current switching frequency. The rising edge of this signal coincides with the rising edge of the SW1 waveform. The duty factor of the signal on CLK\_OUT pin is 50%.
- bq50002 increases the frequency (reduces delivered power) if:
  - PWM\_CTRL pin is LOW
  - MODE pin is LOW
  - UP\_DN pin is LOW
  - CLK\_IN pin changes its state from LOW to HIGH (rising edge)
- bq50002 decreases the frequency (increases delivered power) if:
  - PWM\_CTRL pin is LOW
  - MODE pin is LOW
  - UP\_DN pin is HIGH
  - CLK\_IN pin changes its state from LOW to HIGH (rising edge)

## Feature Description (continued)

### 7.3.2.4 Duty Cycle Adjustment

bq50002 follows the commands from the controller to adjust the internal oscillator duty cycle up or down to adjust power output levels when the following conditions hold:

- The internal clock is set to the highest frequency tap, 205 kHz
- PWM\_CTRL pin is LOW
- MODE pin is HIGH
- bq50002 decreases the duty cycle (reduces delivered power) if:
  - The internal clock is set to the highest frequency tap, 205 kHz or at frequency at which MCU commands MODE = 1
  - PWM\_CTRL pin is LOW
  - MODE pin is HIGH
  - UP\_DN is LOW
  - CLK\_IN pin changes state from LOW to HIGH (rising edge)
  - bq50002 ignores CLK\_IN signals when minimum duty factor position of 10% is reached
- bq50002 increases the duty cycle (increases delivered power) if:
  - The internal clock is set to the highest frequency tap, 205 kHz at frequency at which MCU commands MODE = 1
  - PWM\_CTRL pin is LOW
  - MODE pin is HIGH
  - UP\_DN is HIGH
  - CLK\_IN pin changes state from LOW to HIGH (rising edge)
  - bq50002 ignores CLK\_IN signals when maximum duty factor position of 50% is reached. bq50002 will resume clock frequency adjustment mode only when the duty cycle adjustment has reached the 50% state and MODE=0.

### 7.3.3 Current Sense Amplifier

To support foreign object detection (FOD), bq50002 senses the average input current to the device. The integrated current sense amplifier has voltage gain of 50.

### 7.3.4 Voltage Regulator

bq50002 has an integrated low-dropout (LDO) voltage regulator which supplies power to the companion bq500511 controller. The BP3 pin supplies a regulated 3-V voltage supply and should have a 2.2- $\mu$ F capacitor tied to GND.

## 7.4 Device Functional Modes

### 7.4.1 Power Transfer

Power transfer efficiency and robustness depends on coil coupling. Coupling depends on the distance between coils, alignment, coil dimensions, coil materials, number of turns, magnetic shielding, impedance matching, frequency. Most importantly, the receiver and transmitter coils must be aligned for best coupling and efficient power transfer. The smaller the space between the coils is, the better the coupling. Shielding is added as a backing to both the transmitter and receiver coils to direct the magnetic field to the coupled zone. Magnetic fields outside the coupled zone do not transfer power. Thus, shielding also serves to contain the fields to avoid coupling to other adjacent system components.

Regulation can be achieved by controlling any one of the coil coupling parameters. However, for WPC compatibility, the transmitter-side coils and capacitance are specified and the resonant frequency point is fixed. In the bq500511/bq50002 system power transfer is regulated by changing the operating frequency between 110 kHz to 205 kHz. The higher the frequency, the further from resonance and the lower the power. Duty cycle remains constant at 50% throughout the power band and is reduced only once 205 kHz is reached.

#### 7.4.1.1 Dynamic Power Limiting™

Dynamic Power Limiting™ (DPL) allows operation from a 5-V supply with limited current capability (such as a USB port). When the input voltage is observed drooping, the output power is dynamically limited to reduce the load and provides margin relative to the supply's capability.

Anytime the DPL control loop is regulating the operating point of the transmitter, the LED will indicate that DPL is active. The LED color and flashing pattern are determined by the LED Table. If the receiver sends a Control Error Packet (CEP) with a negative value, (for example, to reduce power to the load), the bq500511 in DPL mode will return to normal operation and respond to this CEP via the standard WPC control loop behavior.

## Device Functional Modes (continued)

### 7.4.2 Communication

Communication within the WPC v1.2 specification is from the receiver to the transmitter. For example, in order to regulate the output of the transmitter, the receiver sends messages requesting the transmitter to increase or decrease power. The receiver communicates by modulating the rectifier voltage and using amplitude modulation (AM) sends packets of information to the transmitter. A packet is comprised of a preamble, a header, the actual message, and a checksum, as defined by the WPC standard.

The receiver sends a packet by modulating an impedance network. This AM signal reflects back as a change in the voltage amplitude on the transmitter coil. In the bq500511/bq50002 system, the bq50002 performs the demodulation function and passes a digitized version of the message to the bq500511 where the message is decoded and processed. For example in response to a Control Error Packet, the bq500511 calculates the required change in output power and in turn controls the bq50002 through the CLK\_OUT, UP\_DOWN, and MODE pins to adjust the operating point and thus its output power.

The modulation impedance network on the receiver can either be resistive or capacitive. Figure 4 shows the resistive modulation approach, where a resistor is periodically added to the load, resulting in an amplitude change in the transmitter voltage. Figure 5 shows the corresponding capacitive modulation approach.

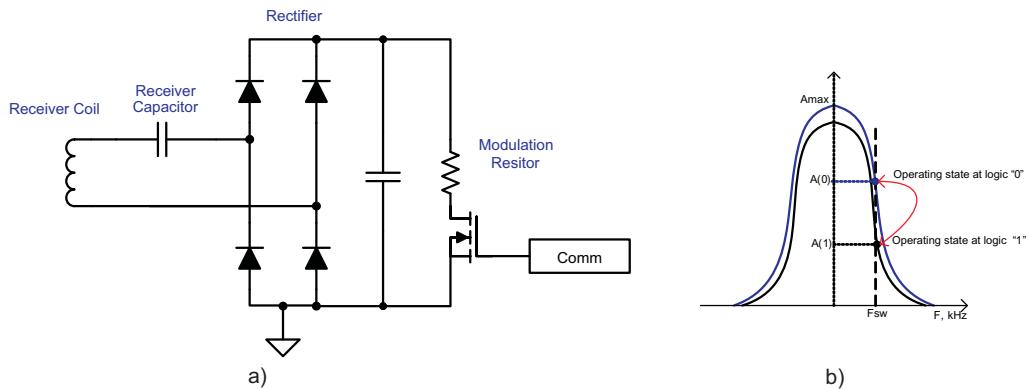

Figure 4. Receiver Resistive Modulation Circuit

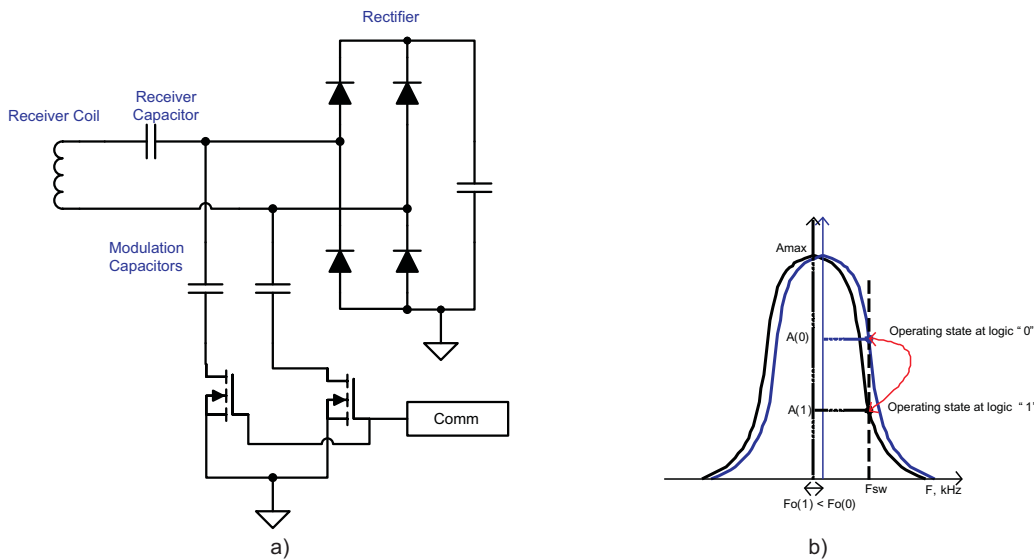

Figure 5. Receiver Capacitive Modulation Circuit

## 8 Application and Implementation

### NOTE

Information in the following applications sections is not part of the TI component specification, and TI does not warrant its accuracy or completeness. TI's customers are responsible for determining suitability of components for their purposes. Customers should validate and test their design implementation to confirm system functionality.

### 8.1 Application Information

The bq50002 device is a wireless power transmitter AFE designed for 5-W WPC compliant applications when paired with the bq500511. The pair integrates all functions required to control wireless power transfer to a WPC v1.2 compliant receiver. Several tools are available for the design of the system. See the product folder on [www.ti.com](http://www.ti.com) for more details. The following sections highlight some of the system design considerations.

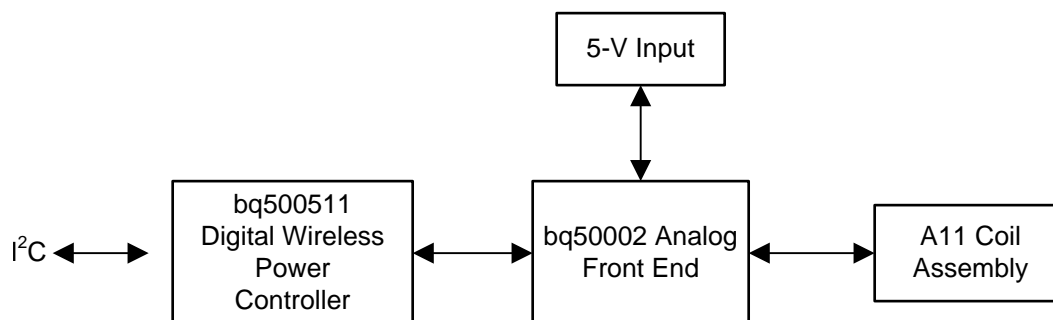

**Figure 6. System Block Diagram**

The I<sup>2</sup>C port is accessed by the FOD tuning tool and can provide a level of system monitoring and evaluation.

The SDA and SCL lines of the I<sup>2</sup>C bus must be pulled up (as shown in the [Figure 7](#)) if the I<sup>2</sup>C port is utilized. They may be left floating if no I<sup>2</sup>C function is required. The logic reference generated by the bq50002 Analog Front End is 3 V, so care should be taken to ensure that if the Master I<sup>2</sup>C device also has pull-up resistors to a higher reference, that the the 3-V reference to the bq500511 is not affected. Specifically, only one set of pull-up resistors should be populated, either on the I<sup>2</sup>C Master bus or on the bq500511 system board, but not both.

## 8.2 Typical Application

The bq50002 is a highly integrated analog front end device which, when paired with the bq500511 controller, requires a minimum of external components to implement a WPC V 1.2 Wireless Power Transmitter system.

As shown in the application schematic, external components are used to implement the following functions:

- Resonant Tank Circuit
- Demodulator Input Signal Conditioning
- Human Interface (LED and Buzzer)
- Current Sensing
- Voltage Sensing
- Temperature Sensing
- System Configuration
  - Foreign Objection Detection (FOD) Threshold and Calibration
  - LED Mode

Typical Application (continued)

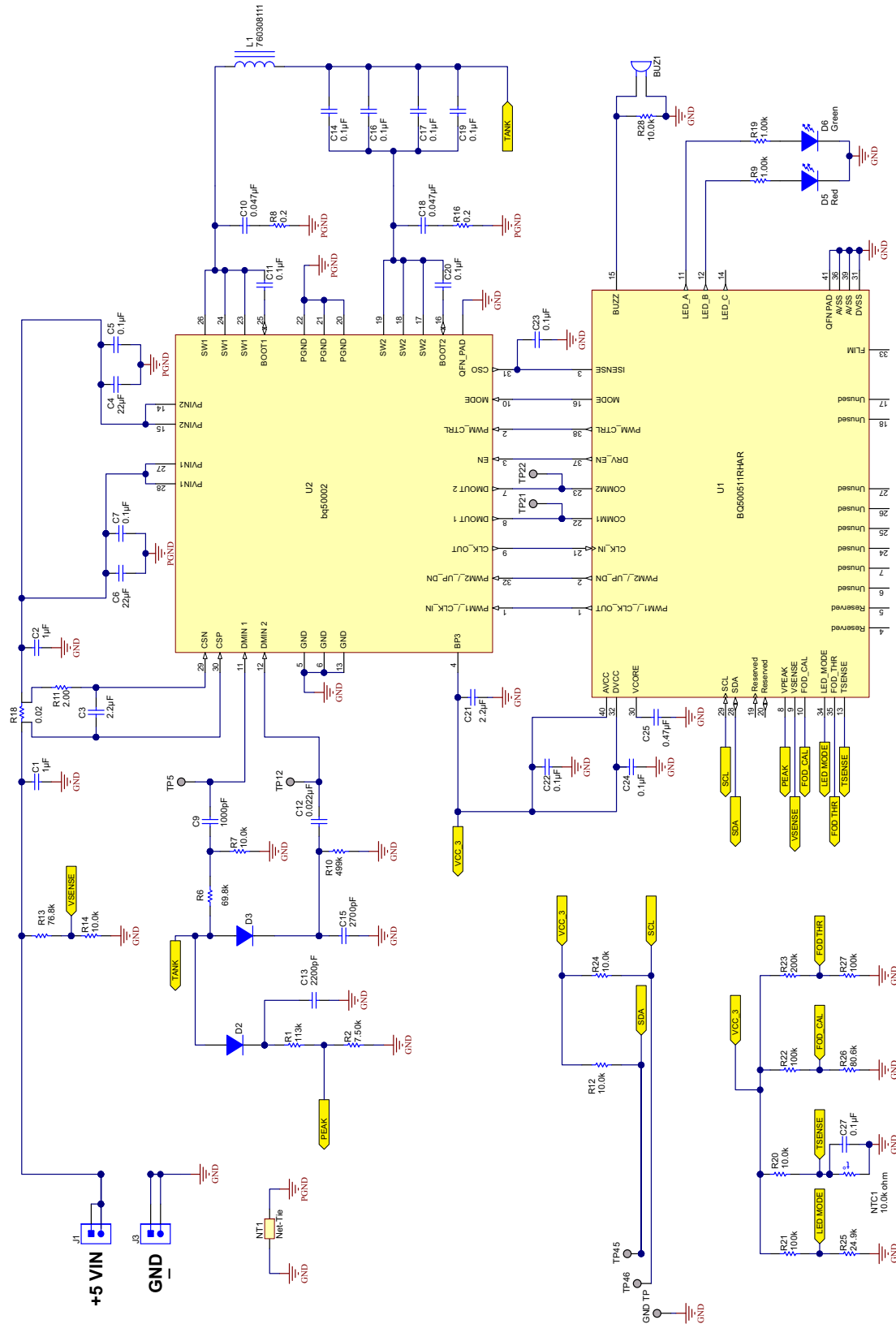

Figure 7. bq500511 Application Schematic



## Typical Application (continued)

### 8.2.1 Design Requirements

DESIGN PARAMETER	VALUE
WPC coil type	A11

### 8.2.2 Detailed Design Procedure

#### 8.2.2.1 Capacitor Selection

Capacitor selection is critical to proper system operation. The total capacitance value of 4 nF × 100 nF is required in the resonant tank. This is the WPC system compatibility requirement, not a guideline.

#### NOTE

A total capacitance value of 4 nF × 100 nF (C0G dielectric type, 50-V rating) is required in the resonant tank to achieve the correct resonance frequency. The capacitors chosen must be rated for at least 50 V and must be of a high-quality C0G dielectric (sometimes also called NP0). These are typically available in a 5% tolerance, which is adequate. TI does **not** recommend the use of X7R types or below if WPC compliance is required because critical WPC Certification Testing, such as the minimum modulation or guaranteed power test, might fail. The designer can combine capacitors to achieve the desired capacitance value. Various combinations can work depending on market availability. All capacitors must be of C0G types (not mixed with any other dielectric types).

#### 8.2.2.2 Current Monitoring Requirements

The bq50002 is WPC v1.2 ready. To enable the FOD feature, current monitoring is provided in the bq50002 Analog Front End. For proper scaling of the current monitor signal, the current sense resistor should be 20 mΩ. For FOD accuracy, the current sense resistor must be a quality component with 0.5% tolerance, at least 1/4-W rating, and a temperature stability of ±200 PPM.

#### 8.2.2.3 Input Regulation

The bq500511 requires 3 VDC to operate. The regulator in the bq50002 provides this voltage rail eliminating the need for any external regulation.

#### 8.2.2.4 System Input Power Requirements

The design works with 5-V input voltage to the bq50002. The WPC defined A11 TX type requires 5-V system voltage in order to deliver 5 W of output power from the receiver.

### 8.2.3 Application Curves

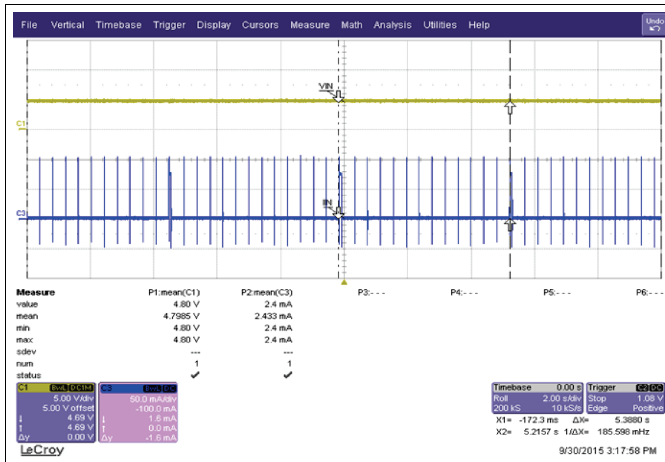

Figure 8. Standby Power

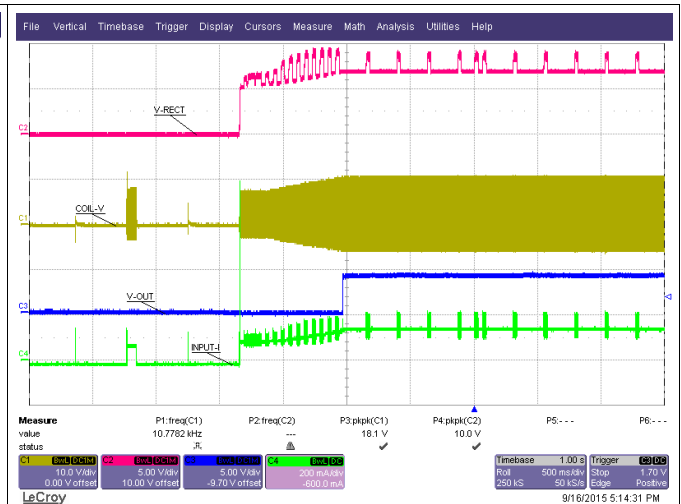

Figure 9. Start-Up with bq51013B

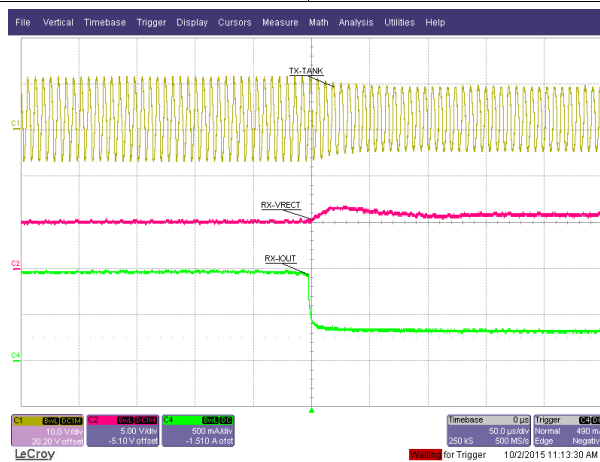

Figure 10. Load-Transient Response

## 9 Power Supply Recommendations

The A11 TX type requires a 5-V system voltage.

## 10 Layout

### 10.1 Layout Guidelines

Careful PCB layout practice is critical to proper system operation. Many references are available on proper PCB layout techniques. A few good tips are as follows.

The TX layout requires a 4-layer PCB layout for best ground plane technique. A 2-layer PCB layout can be achieved though not as easily. Ideally, the approach to the layer stack-up is:

- Layer 1 component placement and as much ground plane as possible
- Layer 2 clean ground
- Layer 3 finish routing
- Layer 4 clean ground

Thus, the circuitry is virtually sandwiched between grounds. This minimizes EMI noise emissions and also provides a noise-free voltage reference plane for device operation.

Keep as much copper as possible. Make sure the bq500511 GND pins have a continuous flood connection to the ground plane. The power pad of the bq50002 should also be stitched to the ground plane, which also acts as a heat sink. A good GND reference is necessary for proper system operation, such as analog-digital conversion, clock stability, and best overall EMI performance. Separate the analog ground plane from the power ground plane and use only **one** tie point to connect grounds. Having several tie points defeats the purpose of separating the grounds. See the bq500511 EVM for an example of a good layout technique.

#### 10.1.1 Layout Notes

Make sure the bypass capacitors intended for the bq500511 3.3-V supply are actually bypassing these supply pins (pin 32, DVCC, and pin 40, AVCC) to solid ground plane (see [Figure 11](#)). This means they need to be placed as close to the device as possible and the traces must be as wide as possible.

Make sure the bq500511 has a continuous flood connection to the ground plane (see [Figure 12](#)).

The full-bridge power stage that drives the TX coil is composed of two half-bridge power stages (integrated in bq50002) and resonant capacitors. Input bypass capacitors should be placed as close as possible to the bq50002 PVIN1 pins (pin 27, 28) and PVIN2 pins (pin 14, 15). The input and ground pours and traces should be made as wide as possible for better current flow. The trace to the coil and resonant capacitors should also be made as wide as possible (see [Figure 13](#)).

To ensure proper operation, grounds conducting a large amount of current and switching noise must be isolated from low current, quiet grounds. Separate the ground pours for the power stages and the bq500511 IC. Connect all grounds to a single point at the main ground terminal (see [Figure 14](#)).

Proper current sensing layout technique is very important, as it directly affects the FOD and PMOD performance. When sampling the very-low voltages generated across a current sense resistor, be sure to use the so called 4-wire or Kelvin-connection technique. This is important to avoid introducing false voltage drops from adjacent pads and copper power routes. It is a common power-supply layout technique. Some high-accuracy sense resistors have dedicated sense pins (see [Figure 15](#)).

The trace from bq50002 CSP pin to sense resistor must be minimized to avoid unwanted offset in the application. This trace should be limited to less than 20 mΩ resistance.

## 10.2 Layout Examples

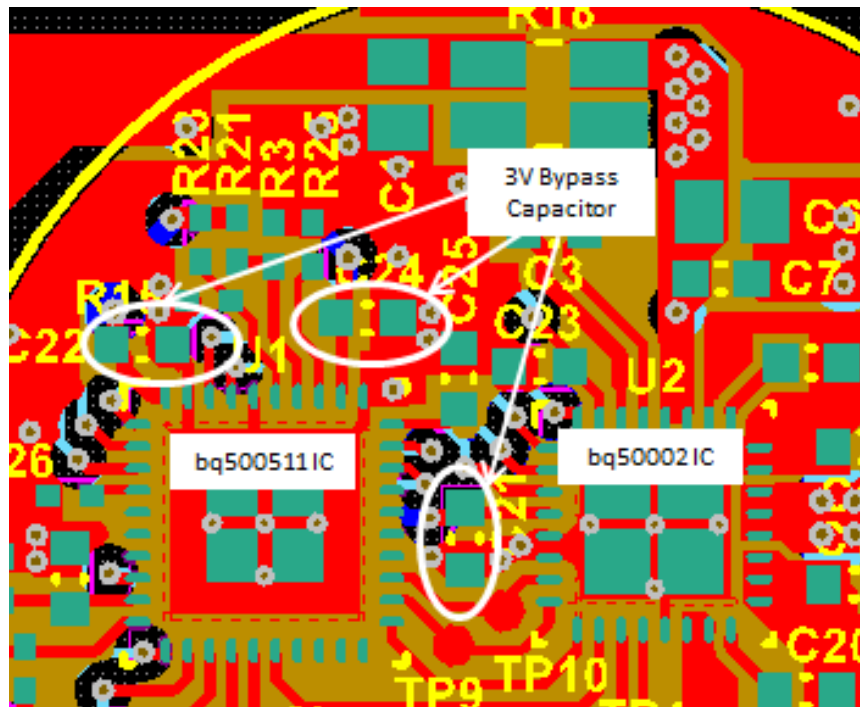

**Figure 11. Bypass Capacitors Layout**

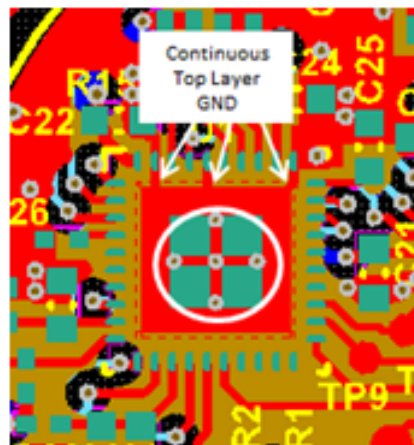

**Figure 12. Continuous GND Layout**

Layout Examples (continued)

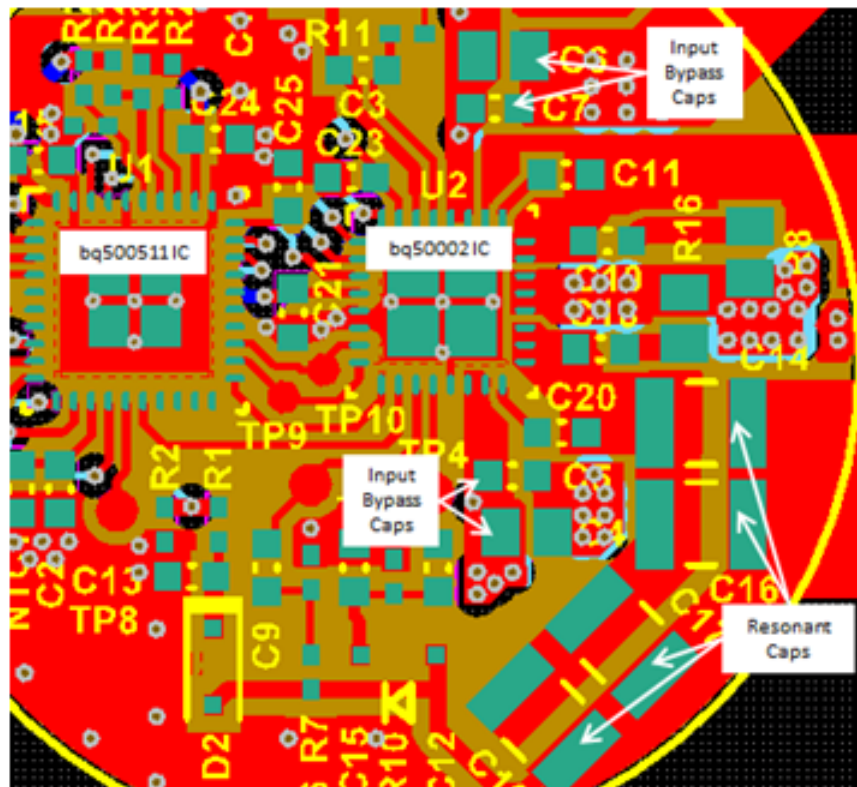

Figure 13. Ground Layout

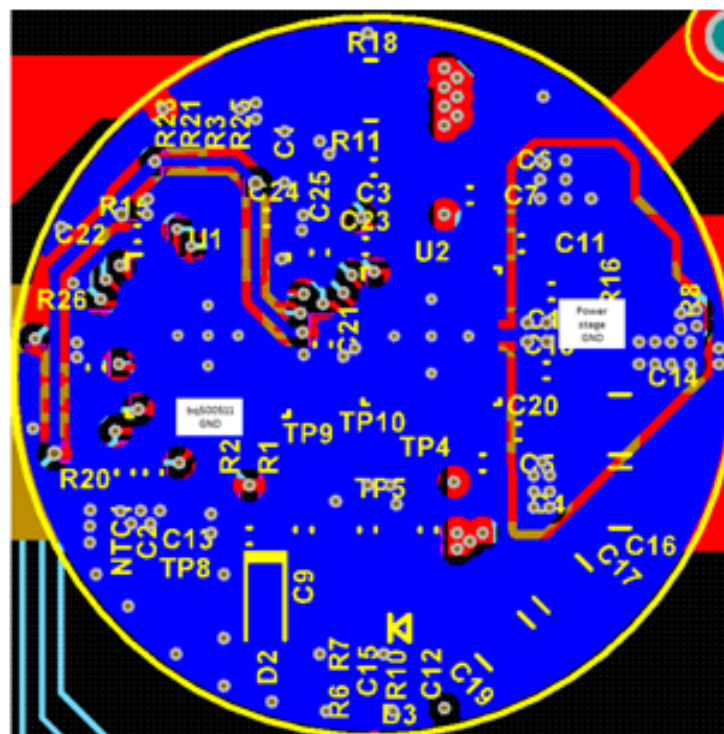
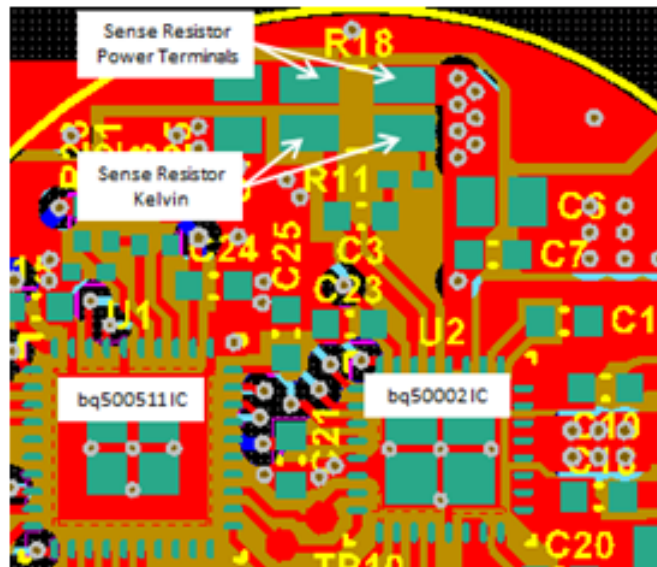

Figure 14. Ground Layout

**Layout Examples (continued)**



**Figure 15. Current Sensing Layout**

## 11 器件和文档支持

### 11.1 文档支持

#### 11.1.1 相关文档

1. 数据表《bq500511 无线电源发送器控制器》（文献编号：SLUSCD3）
2. 评估模块《bq50002 无线电源 Tx EVM》（文献编号：SLVUAJ7）

### 11.2 社区资源

The following links connect to TI community resources. Linked contents are provided "AS IS" by the respective contributors. They do not constitute TI specifications and do not necessarily reflect TI's views; see TI's [Terms of Use](#).

**TI E2E™ Online Community** *TI's Engineer-to-Engineer (E2E) Community*. Created to foster collaboration among engineers. At e2e.ti.com, you can ask questions, share knowledge, explore ideas and help solve problems with fellow engineers.

**Design Support** *TI's Design Support* Quickly find helpful E2E forums along with design support tools and contact information for technical support.

### 11.3 商标

动态电源限制 (DPL), E2E are trademarks of Texas Instruments.  
All other trademarks are the property of their respective owners.

### 11.4 静电放电警告



这些装置包含有限的内置 ESD 保护。存储或装卸时，应将导线一起截短或将装置放置于导电泡棉中，以防止 MOS 门极遭受静电损伤。

### 11.5 Glossary

**SLYZ022** — *TI Glossary*.

This glossary lists and explains terms, acronyms, and definitions.

## 12 机械、封装和可订购信息

以下页中包括机械、封装和可订购信息。 这些信息是针对指定器件可提供的最新数据。 这些数据会在无通知且不对本文档进行修订的情况下发生改变。 欲获得该数据表的浏览器版本，请查阅左侧的导航栏。



## 重要声明

德州仪器(TI)及其下属子公司有权根据 JESD46 最新标准,对所提供的产品和服务进行更正、修改、增强、改进或其它更改,并有权根据 JESD48 最新标准中止提供任何产品和服务。客户在下订单前应获取最新的相关信息,并验证这些信息是否完整且是最新的。所有产品的销售都遵循在订单确认时所提供的TI 销售条款与条件。

TI 保证其所销售的组件的性能符合产品销售时 TI 半导体产品销售条件与条款的适用规范。仅在 TI 保证的范围内,且 TI 认为有必要时才会使用测试或其它质量控制技术。除非适用法律做出了硬性规定,否则没有必要对每种组件的所有参数进行测试。

TI 对应用帮助或客户产品设计不承担任何义务。客户应对其使用 TI 组件的产品和应用自行负责。为尽量减小与客户产品和应用相关的风险,客户应提供充分的设计与操作安全措施。

TI 不对任何 TI 专利权、版权、屏蔽作品权或其它与使用了 TI 组件或服务的组合设备、机器或流程相关的 TI 知识产权中授予的直接或隐含权限作出任何保证或解释。TI 所发布的与第三方产品或服务有关的信息,不能构成从 TI 获得使用这些产品或服务的许可、授权、或认可。使用此类信息可能需要获得第三方的专利权或其它知识产权方面的许可,或是 TI 的专利权或其它知识产权方面的许可。

对于 TI 的产品手册或数据表中 TI 信息的重要部分,仅在没有对内容进行任何篡改且带有相关授权、条件、限制和声明的情况下才允许进行复制。TI 对此类篡改过的文件不承担任何责任或义务。复制第三方的信息可能需要服从额外的限制条件。

在转售 TI 组件或服务时,如果对该组件或服务参数的陈述与 TI 标明的参数相比存在差异或虚假成分,则会失去相关 TI 组件或服务的所有明示或暗示授权,且这是不正当的、欺诈性商业行为。TI 对任何此类虚假陈述均不承担任何责任或义务。

客户认可并同意,尽管任何应用相关信息或支持仍可能由 TI 提供,但他们将独立负责满足与其产品及其在应用中使用的 TI 产品相关的所有法律、法规和安全相关要求。客户声明并同意,他们具备制定与实施安全措施所需的全部专业技术和知识,可预见故障的危险后果、监测故障及其后果、降低有可能造成人身伤害的故障的发生机率并采取适当的补救措施。客户将全额赔偿因在此类安全关键应用中使用任何 TI 组件而对 TI 及其代理造成的任何损失。

在某些场合中,为了推进安全相关应用有可能对 TI 组件进行特别的促销。TI 的目标是利用此类组件帮助客户设计和创立其特有的可满足适用的功能安全性标准和要求的终端产品解决方案。尽管如此,此类组件仍然服从这些条款。

TI 组件未获得用于 FDA Class III (或类似的生命攸关医疗设备)的授权许可,除非各方授权官员已经达成了专门管控此类使用的特别协议。

只有那些 TI 特别注明属于军用等级或“增强型塑料”的 TI 组件才是设计或专门用于军事/航空应用或环境的。购买者认可并同意,对并非指定面向军事或航空航天用途的 TI 组件进行军事或航空航天方面的应用,其风险由客户单独承担,并且由客户独立负责满足与此类使用相关的所有法律和法规要求。

TI 已明确指定符合 ISO/TS16949 要求的产品,这些产品主要用于汽车。在任何情况下,因使用非指定产品而无法达到 ISO/TS16949 要求, TI 不承担任何责任。

	产品		应用
数字音频	<a href="http://www.ti.com.cn/audio">www.ti.com.cn/audio</a>	通信与电信	<a href="http://www.ti.com.cn/telecom">www.ti.com.cn/telecom</a>
放大器和线性器件	<a href="http://www.ti.com.cn/amplifiers">www.ti.com.cn/amplifiers</a>	计算机及周边	<a href="http://www.ti.com.cn/computer">www.ti.com.cn/computer</a>
数据转换器	<a href="http://www.ti.com.cn/dataconverters">www.ti.com.cn/dataconverters</a>	消费电子	<a href="http://www.ti.com.cn/consumer-apps">www.ti.com.cn/consumer-apps</a>
DLP® 产品	<a href="http://www.dlp.com">www.dlp.com</a>	能源	<a href="http://www.ti.com.cn/energy">www.ti.com.cn/energy</a>
DSP - 数字信号处理器	<a href="http://www.ti.com.cn/dsp">www.ti.com.cn/dsp</a>	工业应用	<a href="http://www.ti.com.cn/industrial">www.ti.com.cn/industrial</a>
时钟和计时器	<a href="http://www.ti.com.cn/clockandtimers">www.ti.com.cn/clockandtimers</a>	医疗电子	<a href="http://www.ti.com.cn/medical">www.ti.com.cn/medical</a>
接口	<a href="http://www.ti.com.cn/interface">www.ti.com.cn/interface</a>	安防应用	<a href="http://www.ti.com.cn/security">www.ti.com.cn/security</a>
逻辑	<a href="http://www.ti.com.cn/logic">www.ti.com.cn/logic</a>	汽车电子	<a href="http://www.ti.com.cn/automotive">www.ti.com.cn/automotive</a>
电源管理	<a href="http://www.ti.com.cn/power">www.ti.com.cn/power</a>	视频和影像	<a href="http://www.ti.com.cn/video">www.ti.com.cn/video</a>
微控制器 (MCU)	<a href="http://www.ti.com.cn/microcontrollers">www.ti.com.cn/microcontrollers</a>		
RFID 系统	<a href="http://www.ti.com.cn/rfidsys">www.ti.com.cn/rfidsys</a>		
OMAP应用处理器	<a href="http://www.ti.com/omap">www.ti.com/omap</a>		
无线连通性	<a href="http://www.ti.com.cn/wirelessconnectivity">www.ti.com.cn/wirelessconnectivity</a>	德州仪器在线技术支持社区	<a href="http://www.deyisupport.com">www.deyisupport.com</a>

邮寄地址: 上海市浦东新区世纪大道1568号, 中建大厦32楼邮政编码: 200122  
Copyright © 2015, 德州仪器半导体技术(上海)有限公司

**PACKAGING INFORMATION**

Orderable Device	Status (1)	Package Type	Package Drawing	Pins	Package Qty	Eco Plan (2)	Lead finish/ Ball material (6)	MSL Peak Temp (3)	Op Temp (°C)	Device Marking (4/5)	Samples
BQ50002RHBR	NRND	VQFN	RHB	32	3000	RoHS & Green	NIPDAU	Level-2-260C-1 YEAR	-40 to 125	BQ50002	
BQ50002RHBT	NRND	VQFN	RHB	32	250	RoHS & Green	NIPDAU	Level-2-260C-1 YEAR	-40 to 125	BQ50002	

(1) The marketing status values are defined as follows:

**ACTIVE:** Product device recommended for new designs.

**LIFEBUY:** TI has announced that the device will be discontinued, and a lifetime-buy period is in effect.

**NRND:** Not recommended for new designs. Device is in production to support existing customers, but TI does not recommend using this part in a new design.

**PREVIEW:** Device has been announced but is not in production. Samples may or may not be available.

**OBSOLETE:** TI has discontinued the production of the device.

(2) **RoHS:** TI defines "RoHS" to mean semiconductor products that are compliant with the current EU RoHS requirements for all 10 RoHS substances, including the requirement that RoHS substance do not exceed 0.1% by weight in homogeneous materials. Where designed to be soldered at high temperatures, "RoHS" products are suitable for use in specified lead-free processes. TI may reference these types of products as "Pb-Free".

**RoHS Exempt:** TI defines "RoHS Exempt" to mean products that contain lead but are compliant with EU RoHS pursuant to a specific EU RoHS exemption.

**Green:** TI defines "Green" to mean the content of Chlorine (Cl) and Bromine (Br) based flame retardants meet JS709B low halogen requirements of <=1000ppm threshold. Antimony trioxide based flame retardants must also meet the <=1000ppm threshold requirement.

(3) MSL, Peak Temp. - The Moisture Sensitivity Level rating according to the JEDEC industry standard classifications, and peak solder temperature.

(4) There may be additional marking, which relates to the logo, the lot trace code information, or the environmental category on the device.

(5) Multiple Device Markings will be inside parentheses. Only one Device Marking contained in parentheses and separated by a "~" will appear on a device. If a line is indented then it is a continuation of the previous line and the two combined represent the entire Device Marking for that device.

(6) Lead finish/Ball material - Orderable Devices may have multiple material finish options. Finish options are separated by a vertical ruled line. Lead finish/Ball material values may wrap to two lines if the finish value exceeds the maximum column width.

**Important Information and Disclaimer:**The information provided on this page represents TI's knowledge and belief as of the date that it is provided. TI bases its knowledge and belief on information provided by third parties, and makes no representation or warranty as to the accuracy of such information. Efforts are underway to better integrate information from third parties. TI has taken and continues to take reasonable steps to provide representative and accurate information but may not have conducted destructive testing or chemical analysis on incoming materials and chemicals. TI and TI suppliers consider certain information to be proprietary, and thus CAS numbers and other limited information may not be available for release.

In no event shall TI's liability arising out of such information exceed the total purchase price of the TI part(s) at issue in this document sold by TI to Customer on an annual basis.

## GENERIC PACKAGE VIEW

**RHB 32**

**VQFN - 1 mm max height**

5 x 5, 0.5 mm pitch

PLASTIC QUAD FLATPACK - NO LEAD



Images above are just a representation of the package family, actual package may vary.  
Refer to the product data sheet for package details.

4224745/A

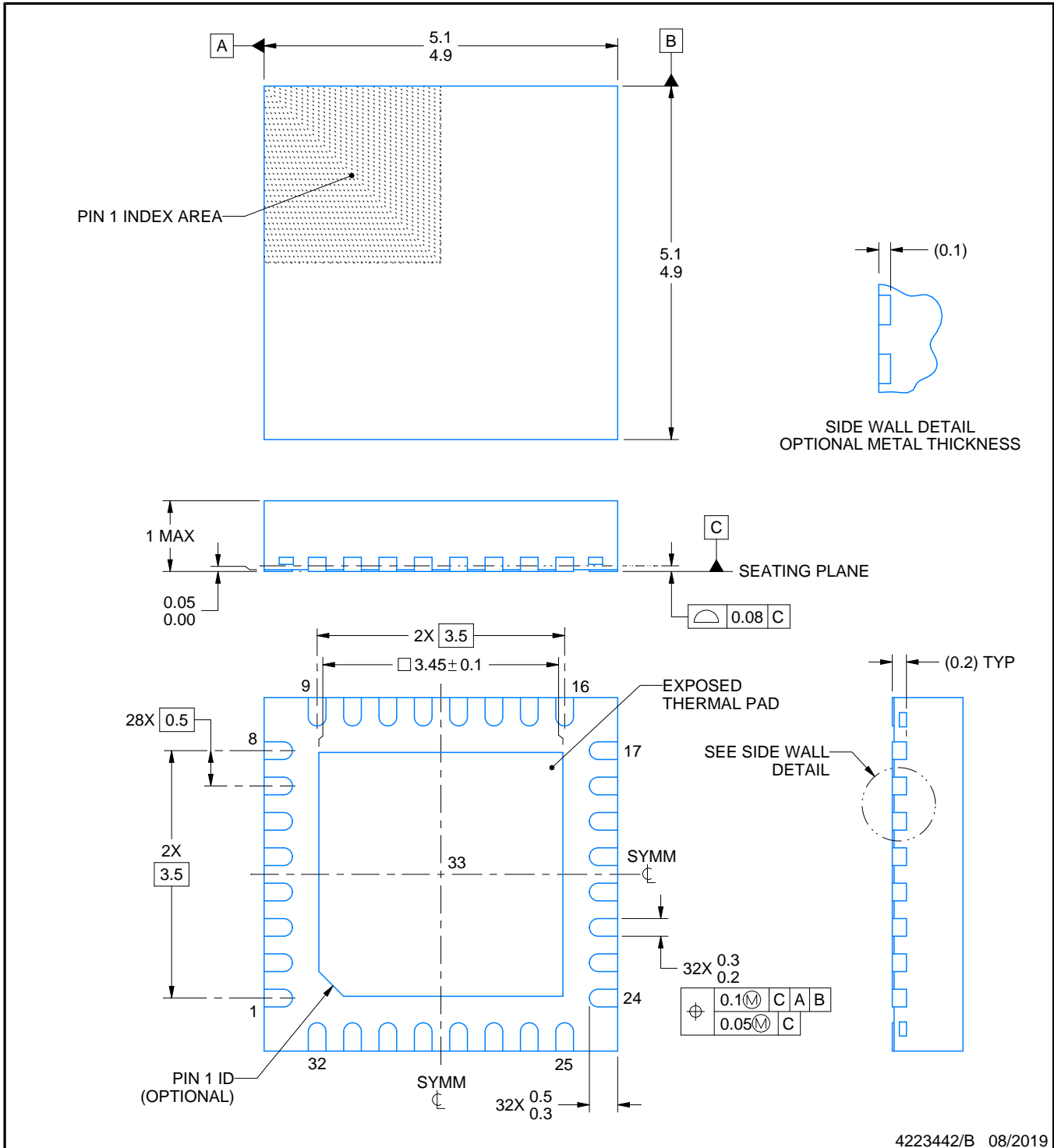
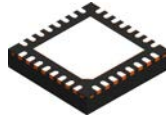

4223442/B 08/2019

NOTES:

1. All linear dimensions are in millimeters. Any dimensions in parenthesis are for reference only. Dimensioning and tolerancing per ASME Y14.5M.
2. This drawing is subject to change without notice.
3. The package thermal pad must be soldered to the printed circuit board for thermal and mechanical performance.

# EXAMPLE BOARD LAYOUT

RHB0032E

VQFN - 1 mm max height

PLASTIC QUAD FLATPACK - NO LEAD



LAND PATTERN EXAMPLE  
SCALE:18X



SOLDER MASK DETAILS

4223442/B 08/2019

NOTES: (continued)

4. This package is designed to be soldered to a thermal pad on the board. For more information, see Texas Instruments literature number SLUA271 ([www.ti.com/lit/sluea271](http://www.ti.com/lit/sluea271)).
5. Vias are optional depending on application, refer to device data sheet. If any vias are implemented, refer to their locations shown on this view. It is recommended that vias under paste be filled, plugged or tented.

# EXAMPLE STENCIL DESIGN

RHB0032E

VQFN - 1 mm max height

PLASTIC QUAD FLATPACK - NO LEAD



**SOLDER PASTE EXAMPLE**  
 BASED ON 0.125 mm THICK STENCIL

EXPOSED PAD 33:  
 75% PRINTED SOLDER COVERAGE BY AREA UNDER PACKAGE  
 SCALE:20X

4223442/B 08/2019

NOTES: (continued)

6. Laser cutting apertures with trapezoidal walls and rounded corners may offer better paste release. IPC-7525 may have alternate design recommendations.

## 重要声明和免责声明

TI 均以“原样”提供技术性 & 可靠性数据（包括数据表）、设计资源（包括参考设计）、应用或其他设计建议、网络工具、安全信息和其他资源，不保证其中不含任何瑕疵，且不做任何明示或暗示的担保，包括但不限于对适销性、适合某特定用途或不侵犯任何第三方知识产权的暗示担保。

所述资源可供专业开发人员应用 TI 产品进行设计使用。您将对以下行为独自承担全部责任：(1) 针对您的应用选择合适的 TI 产品；(2) 设计、验证并测试您的应用；(3) 确保您的应用满足相应标准以及任何其他安全、安保或其他要求。所述资源如有变更，恕不另行通知。TI 对您使用所述资源的授权仅限于开发资源所涉及 TI 产品的相关应用。除此之外不得复制或展示所述资源，也不提供其它 TI 或任何第三方的知识产权授权许可。如因使用所述资源而产生任何索赔、赔偿、成本、损失及债务等，TI 对此概不负责，并且您须赔偿由此对 TI 及其代表造成的损害。

TI 所提供产品均受 TI 的销售条款 (<http://www.ti.com.cn/zh-cn/legal/termsofsale.html>) 以及 [ti.com.cn](http://www.ti.com.cn) 上或随附 TI 产品提供的其他可适用条款的约束。TI 提供所述资源并不扩展或以其他方式更改 TI 针对 TI 产品所发布的可适用的担保范围或担保免责声明。

邮寄地址：上海市浦东新区世纪大道 1568 号中建大厦 32 楼，邮政编码：200122

Copyright © 2020 德州仪器半导体技术（上海）有限公司