

BUF634 250mA 高速缓冲器

此器件的新版本现已上市: [BUF634A](#)

1 特性

- 此器件的新版本现已上市: [BUF634A](#)
- 高输出电流: 250mA
- 压摆率: 2000V/μs
- 引脚选择带宽: 30MHz 至 180MHz
- 低静态电流: 1.5mA (30MHz BW)
- 宽电源范围: ±2.25V 至 ±18V
- 内部电流限制
- 热关断保护
- 8 引脚 PDIP、SOIC-8、5 引线 TO-220、5 引线 DDPAK-TO-263 表面贴装

2 应用

- 阀驱动器
- 电磁阀驱动器
- 运算放大器电流提升器
- 线路驱动器
- 耳机驱动器
- 视频驱动器
- 电机驱动器
- 测试设备
- ATE 引脚驱动器

3 说明

BUF634 是一款建议用于各种应用的高速、单位增益、开环缓冲器。BUF634 可用于运算放大器的反馈环路内, 以增大输出电流, 消除热反馈, 以及提高电容负载驱动能力。

对于低功耗应用, BUF634 具有 1.5mA 的工作静态电流以及 250mA 的输出、

2000V/μs 的压摆率和 30MHz 带宽。通过在 V- 和 BW 引脚之间连接一个电阻器, 可以在 30MHz 至 180MHz 范围内调节带宽。

输出电路通过内部电流限制和热关断受到全面保护, 使该器件非常耐用且易于使用。

BUF634 采用多种封装以适应机械和功率耗散的要求。包含 8 引脚 PDIP、SOIC-8 表面贴装、5 引线 TO-220 和 5 引线 DDPAK-TO-263 表面贴装塑料电源封装类型。

升级后的 [BUF634A](#) 器件可在静态电流降低 40% 的情况下提供更宽的带宽 (210MHz) 和更高的压摆率 (3750V/μs)。请参阅 [器件比较表](#), 了解如何选择德州仪器 (TI) 提供的单位增益开环缓冲器。

器件信息⁽¹⁾

器件型号	封装	封装尺寸 (标称值)
BUF634	SOIC (8)	3.91mm × 4.90mm
	PDIP (8)	6.35mm × 9.81mm
	TO-220 (5)	8.51mm × 10.16mm
	DDPAK/TO-263 (5)	8.42mm × 10.16mm

(1) 如需了解所有可用封装, 请参阅产品说明书末尾的可订购产品附录。

提升任何运算放大器的输出电流

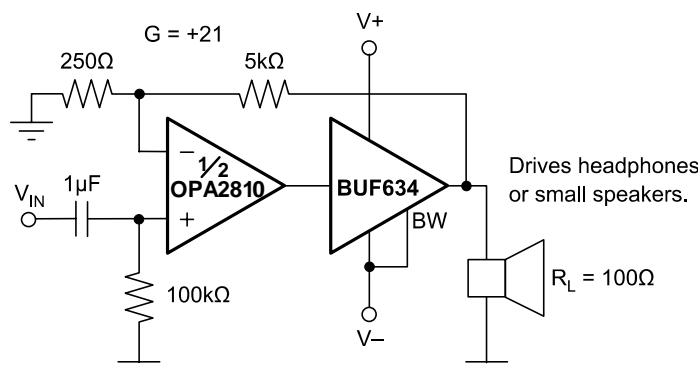

目录

1	特性	1	8.4	Device Functional Modes.....	11
2	应用	1	9	Application and Implementation	12
3	说明	1	9.1	Application Information.....	12
4	修订历史记录	2	9.2	Typical Application	14
5	Device Comparison Table	3	10	Power Supply Recommendations	15
6	Pin Configuration and Functions	3	11	Layout.....	15
7	Specifications.....	4	11.1	Layout Guidelines	15
7.1	Absolute Maximum Ratings	4	11.2	Layout Example	17
7.2	ESD Ratings	4	12	器件和文档支持	18
7.3	Recommended Operating Conditions.....	4	12.1	器件支持	18
7.4	Thermal Information	4	12.2	文档支持	18
7.5	Electrical Characteristics.....	5	12.3	接收文档更新通知	18
7.6	Typical Characteristics.....	7	12.4	社区资源	18
8	Detailed Description	10	12.5	商标	19
8.1	Overview	10	12.6	静电放电警告.....	19
8.2	Functional Block Diagram	10	12.7	术语表	19
8.3	Feature Description.....	11	13	机械、封装和可订购信息	19

4 修订历史记录

注：之前版本的页码可能与当前版本有所不同。

Changes from Revision A (November 2015) to Revision B	Page
• 已添加 向 <i>特性</i> 和 <i>说明</i> 部分添加了 BUF634A 升级器件的有关讨论	1
• 已更改 将放大器更改为 OPA2810 并从提升任何运算放大器的输出电流 图中删除了表格	1
• Added <i>Device Comparison Table</i>	3

Changes from Original (September 2000) to Revision A	Page
• 添加了 <i>ESD</i> 额定值表、 <i>特性说明</i> 部分、 <i>器件功能模式</i> 、 <i>应用和实施</i> 部分、 <i>电源建议</i> 部分、 <i>布局</i> 部分、 <i>器件和文档支持</i> 部分以及 <i>机械、封装和可订购信息</i> 部分。	1

5 Device Comparison Table

DEVICE	$V_{S\pm}$ (V)	I_Q /CHANNEL (mA)	BW (MHz)	SLEW RATE (V/ μ s)	VOLTAGE NOISE (nV/ $\sqrt{\text{Hz}}$)	AMPLIFIER DESCRIPTION
BUF634A	± 18	1.5 – 8.5	35 – 210	3750	3.4	Unity-gain, open-loop buffer
BUF634	± 18	1.5 – 15	30 – 180	2000	4	Unity-gain, open-loop buffer
LMH6321	± 18	11	110	1800	2.8	Unity-gain, open-loop buffer with adjustable current limit

6 Pin Configuration and Functions

**P and D Packages
8-Pin PDIP and SOIC
Top View**

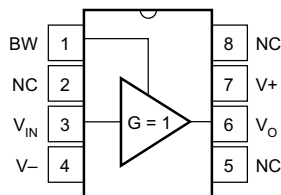

**KC Package
5-Pin TO-220
Top View**

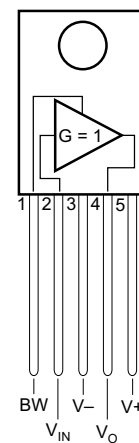

**KTT Package
5-Pin DDPAK/TO-263
Top View**

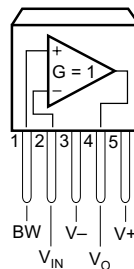

Pin Functions

NAME	PIN NO.		I/O	DESCRIPTION
	8 PINS	5 PINS		
BW	1	1	I	Bandwidth adjust pin
NC	2, 5, 8	—	–	No internal connection
V+	7	5	I	Positive power supply
V _{IN}	3	2	I	Input
V _O	6	4	O	Output
V-	4	3	I	Negative power supply

BUF634

ZHCSJJ0B – SEPTEMBER 2000 – REVISED MARCH 2019

www.ti.com.cn

7 Specifications

7.1 Absolute Maximum Ratings

over operating free-air temperature range (unless otherwise noted) ⁽¹⁾

	MIN	MAX	UNIT
Supply voltage		±18	V
Input voltage		±V _S	
Output short-circuit (to ground)		Continuous	
Operating temperature	-40	125	°C
Junction temperature		150	°C
Lead temperature (soldering, 10 s)		300	°C
Storage temperature, T _{stg}	-55	125	°C

(1) Stresses beyond those listed under *Absolute Maximum Ratings* may cause permanent damage to the device. These are stress ratings only, which do not imply functional operation of the device at these or any other conditions beyond those indicated under *Recommended Operating Conditions*. Exposure to absolute-maximum-rated conditions for extended periods may affect device reliability.

7.2 ESD Ratings

			VALUE	UNIT
BUF634F in PDIP and SOIC Packages				
V _(ESD)	Electrostatic discharge	Human-body model (HBM), per ANSI/ESDA/JEDEC JS-001 ⁽¹⁾	±2500	V
BUF634F in SOIC-8 Package Only				
V _(ESD)	Electrostatic discharge,	Charged-device model (CDM), per JEDEC specification JESD22-C101 ⁽²⁾	±1000	V
BUF634F in TO-220 and DPAK Packages				
V _(ESD)	Electrostatic discharge	Human-body model (HBM), per ANSI/ESDA/JEDEC JS-001 ⁽¹⁾	±2500	V

(1) JEDEC document JEP155 states that 500-V HBM allows safe manufacturing with a standard ESD control process.

(2) JEDEC document JEP157 states that 250-V CDM allows safe manufacturing with a standard ESD control process.

7.3 Recommended Operating Conditions

over operating free-air temperature range (unless otherwise noted)

		MIN	NOM	MAX	UNIT
V _S = (V ₊) - (V ₋)	Supply voltage	±2.25 (4.5)	±15 (30)	±18 (36)	V
T _A	Operating temperature	-40	+25	+85	°C

7.4 Thermal Information

THERMAL METRIC ⁽¹⁾		BUF634				UNIT
		PDIP	SOIC	TO-220	DDPAK-TO-263	
		8 PINS	8 PINS	5 PINS	5 PINS	
R _{θJA}	Junction-to-ambient thermal resistance	46.5	103.4	32.1	41.8	°C/W
R _{θJC(top)}	Junction-to-case (top) thermal resistance	34.8	44.2	25.6	45	°C/W
R _{θJB}	Junction-to-board thermal resistance	23.8	44.5	18.3	24.8	°C/W
ψ _{JT}	Junction-to-top characterization parameter	12	5.4	8.5	13.1	°C/W
ψ _{JB}	Junction-to-board characterization parameter	23.6	43.8	17.7	23.8	°C/W
R _{θJC(bot)}	Junction-to-case (bottom) thermal resistance	n/a	n/a	0.7	2.4	°C/W

(1) For more information about traditional and new thermal metrics, see the [Semiconductor and IC Package Thermal Metrics application report](#).

7.5 Electrical Characteristics

at $T_A = +25^\circ\text{C}^{(1)}$, $V_S = \pm 15\text{ V}$, specifications are for both low quiescent-current mode and wide-bandwidth mode (unless otherwise noted)

PARAMETER		TEST CONDITIONS		MIN	TYP	MAX	UNIT
INPUT							
Offset Voltage					±30	±100	mV
Offset Voltage vs Temperature		Specified Temperature Range			±100		$\mu\text{V}/^\circ\text{C}$
Offset Voltage vs Power Supply		$V_S = \pm 2.25\text{ V}^{(2)}$ to $\pm 18\text{ V}$			0.1	1	mV/V
Input Bias Current		$V_{IN} = 0\text{ V}$	Low Quiescent Current Mode		±0.5	±2	μA
			Wide Bandwidth Mode		±5	±20	
Input Impedance		$R_L = 100\ \Omega$	Low Quiescent Current Mode		80 8		$\text{M}\Omega \parallel \text{pF}$
			Wide Bandwidth Mode		8 8		
Noise Voltage		$f = 10\text{ kHz}$			4		$\text{nV}/\sqrt{\text{Hz}}$
GAIN							
Gain		$R_L = 1\text{ k}\Omega$, $V_O = \pm 10\text{ V}$		0.95	0.99		V/V
		$R_L = 100\ \Omega$, $V_O = \pm 10\text{ V}$		0.85	0.93		
		$R_L = 67\ \Omega$, $V_O = \pm 10\text{ V}$		0.8	0.9		
OUTPUT							
Current Output, Continuous					±250		mA
Voltage Output		Positive	$I_O = 10\text{ mA}$	(V+) -2.1	(V+) -1.7		V
		Negative	$I_O = -10\text{ mA}$	(V-) +2.1	(V-) +1.8		
		Positive	$I_O = 100\text{ mA}$	(V+) -3	(V+) -2.4		
		Negative	$I_O = -100\text{ mA}$	(V-) +4	(V-) +3.5		
		Positive	$I_O = 150\text{ mA}$	(V+) -4	(V+) -2.8		
		Negative	$I_O = -150\text{ mA}$	(V-) +5	(V-) +4		
Short-Circuit Current		Low Quiescent Current Mode			±350	±550	mA
		Wide Bandwidth Mode			±400	±550	
DYNAMIC RESPONSE							
Bandwidth, -3dB		$R_L = 1\text{ k}\Omega$	Low Quiescent Current Mode		30		MHz
			Wide Bandwidth Mode		180		
		$R_L = 100\ \Omega$	Low Quiescent Current Mode		20		
			Low Quiescent Current Mode		160		
Slew Rate		20 Vp-p , $R_L = 100\ \Omega$			2000		V/ μs
Settling Time	0.1%	20-V Step , $R_L = 100\ \Omega$			200		ns
	1%				50		
Differential Gain		3.58 MHz , $V_O = 0.7\text{ V}$, $R_L = 150\ \Omega$	Low Quiescent Current Mode		4%		
			Wide Bandwidth Mode		0.4%		
Differential Phase		3.58 MHz , $V_O = 0.7\text{ V}$, $R_L = 150\ \Omega$	Low Quiescent Current Mode		2.5		°
			Wide Bandwidth Mode		0.1		

- (1) Tests are performed on high speed automatic test equipment, at approximately 25°C junction temperature. The power dissipation of this product will cause some parameters to shift when warmed up. See [Typical Characteristics](#) for over-temperature performance.
- (2) Limited output swing available at low supply voltage. See Output voltage specifications.

BUF634

ZHCSJJ0B – SEPTEMBER 2000 – REVISED MARCH 2019

www.ti.com.cn**Electrical Characteristics (continued)**

at $T_A = +25^\circ\text{C}^{(1)}$, $V_S = \pm 15\text{ V}$, specifications are for both low quiescent-current mode and wide-bandwidth mode (unless otherwise noted)

PARAMETER		TEST CONDITIONS		MIN	TYP	MAX	UNIT
POWER SUPPLY							
	Specified Operating Voltage				±15		V
	Operating Voltage Range			±2.25 ⁽²⁾		±18	V
I_Q	Quiescent Current	$I_O = 0$	Low Quiescent Current Mode		±1.5	±2	mA
			Wide Bandwidth Mode		±15	±20	
TEMPERATURE RANGE							
	Specification			–40		85	°C
	Operating			–40		125	°C
T_J	Thermal Shutdown Temperature				175		°C

7.6 Typical Characteristics

at $T_A = 25^\circ\text{C}$, $V_S = \pm 15\text{ V}$ (unless otherwise noted)

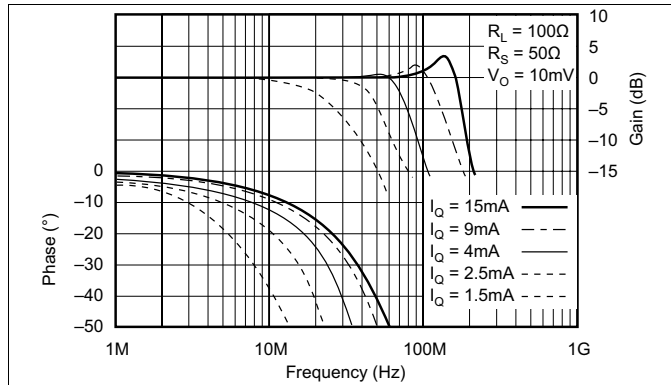

Figure 1. Gain and Phase vs Frequency vs Quiescent Current

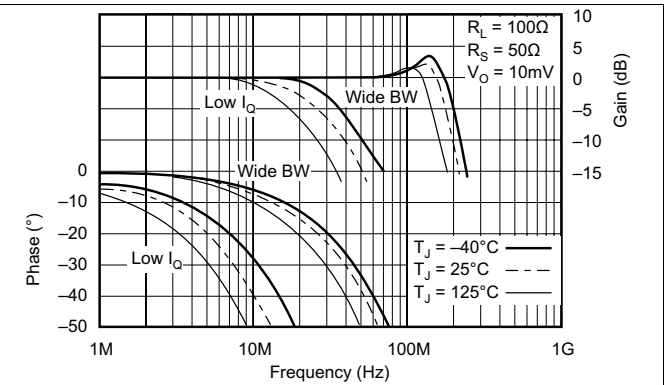

Figure 2. Gain and Phase vs Frequency vs Temperature

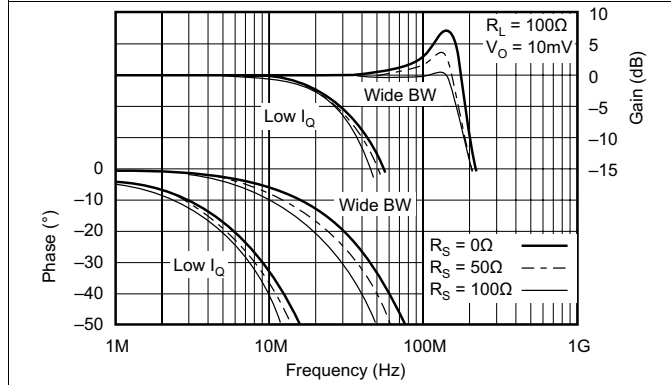

Figure 3. Gain and Phase vs Frequency vs Source Resistance

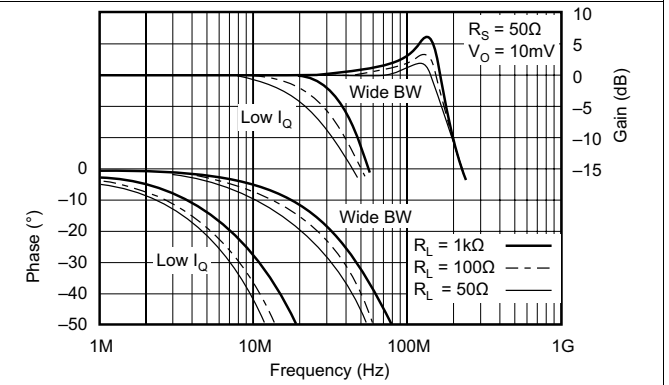

Figure 4. Gain and Phase vs Frequency vs Load Resistance

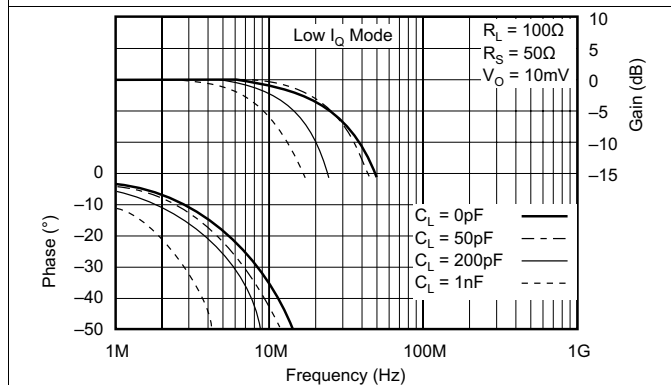

Figure 5. Gain and Phase vs Frequency vs Load Capacitance

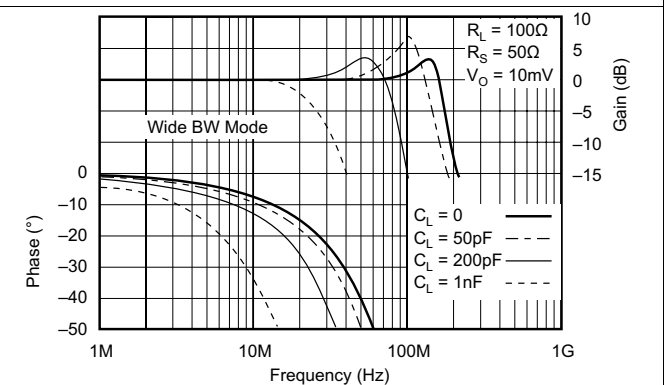

Figure 6. Gain and Phase vs Frequency vs Load Capacitance

BUF634

ZHCSJ0B – SEPTEMBER 2000 – REVISED MARCH 2019

www.ti.com.cn

Typical Characteristics (continued)

at $T_A = 25^\circ\text{C}$, $V_S = \pm 15\text{ V}$ (unless otherwise noted)

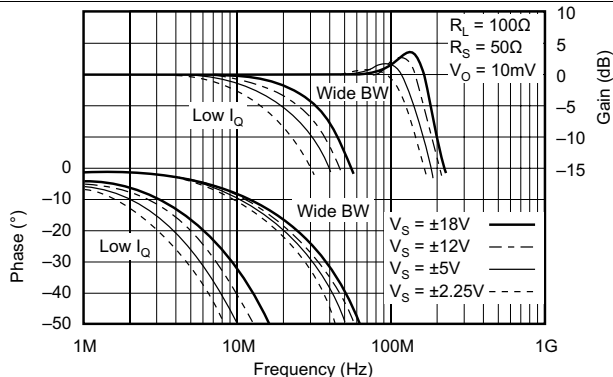

Figure 7. Gain and Phase vs Frequency vs Power Supply Voltage

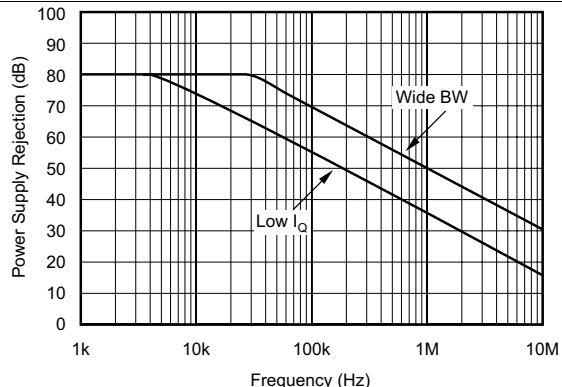

Figure 8. Power Supply Rejection vs Frequency

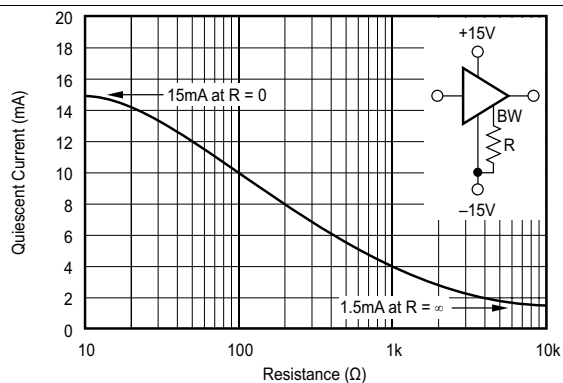

Figure 9. Quiescent Current vs Bandwidth Control Resistance

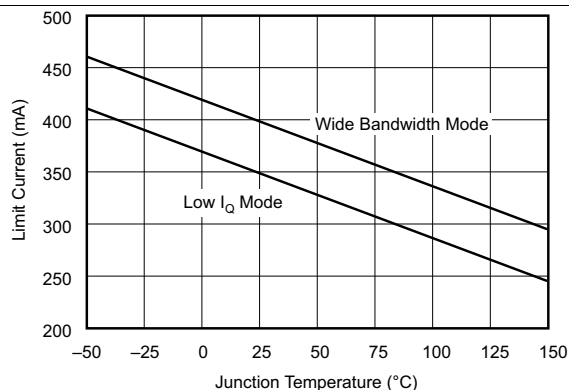

Figure 10. Short-Circuit Current vs Temperature

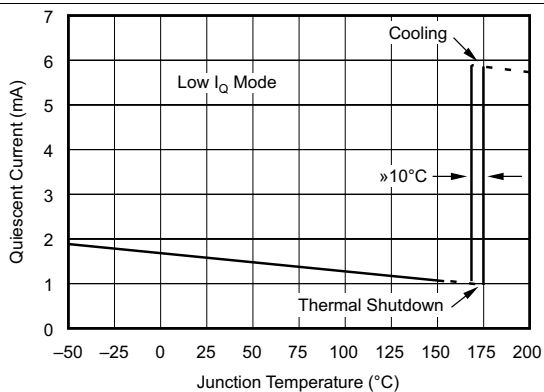

Figure 11. Quiescent Current vs Temperature

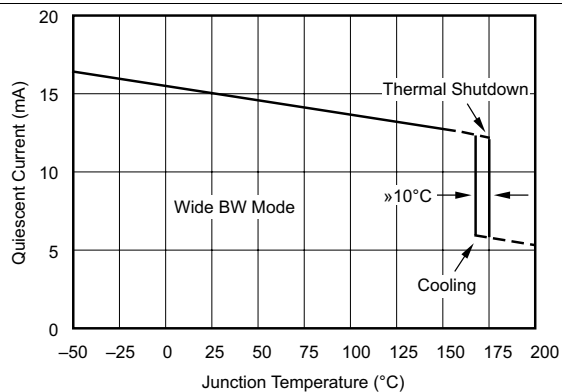

Figure 12. Quiescent Current vs Temperature

Typical Characteristics (continued)

at $T_A = 25^\circ\text{C}$, $V_S = \pm 15\text{ V}$ (unless otherwise noted)

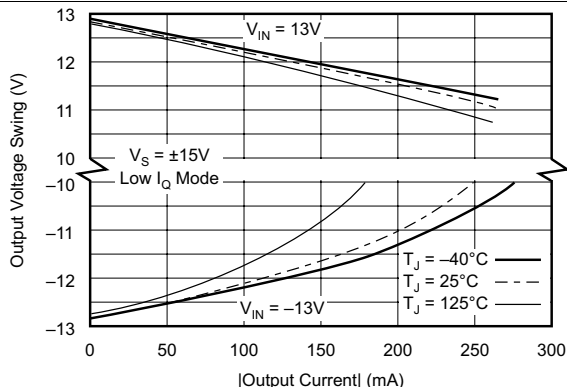

Figure 13. Output Voltage Swing vs Output Current

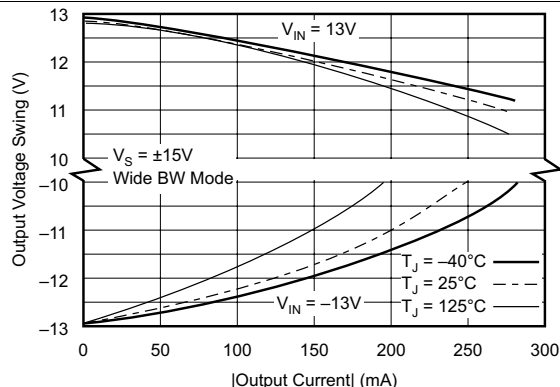

Figure 14. Output Voltage Swing vs Output Current

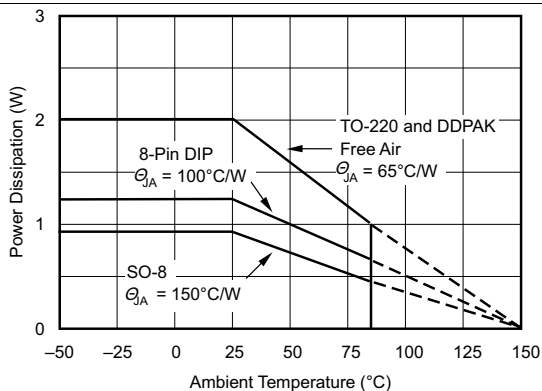

Figure 15. Maximum Power Dissipation vs Temperature

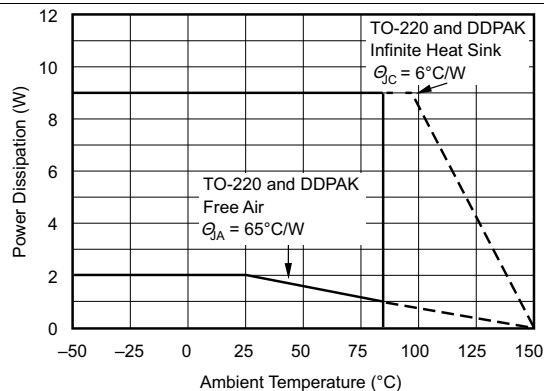

Figure 16. Maximum Power Dissipation vs Temperature

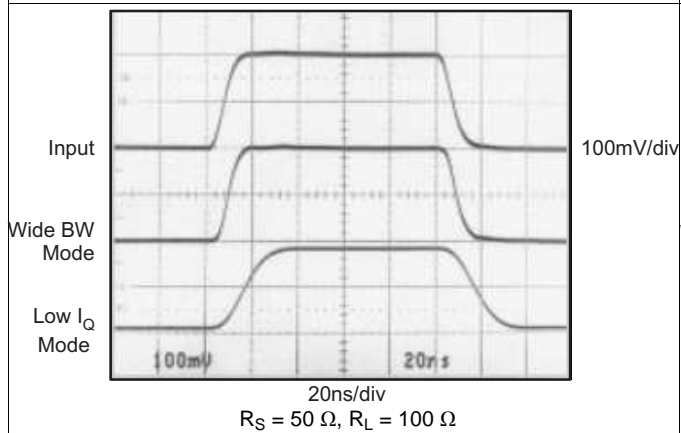

Figure 17. Small-Signal Response

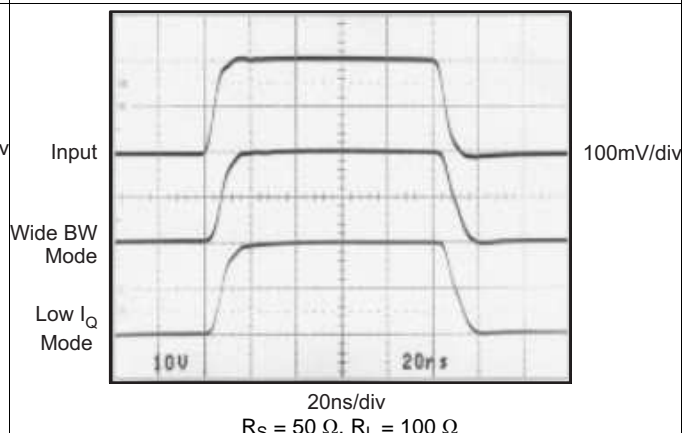

Figure 18. Large-Signal Response

BUF634

ZHCSJ0B – SEPTEMBER 2000 – REVISED MARCH 2019

www.ti.com.cn

8 Detailed Description

8.1 Overview

The BUF634 device is a high speed, unity-gain open-loop buffer recommended for a wide range of applications. The BUF634 device can be used inside the feedback loop of op amps to increase output current, eliminate thermal feedback, and improve capacitive load drive.

For low power applications, the BUF634 device operates on 1.5-mA quiescent current with 250-mA output, 2000-V/ μ s slew rate, and 30-MHz bandwidth. Bandwidth can be adjusted from 30 MHz to 180 MHz by connecting a resistor between V^- and the BW Pin refer to [Figure 9](#) and [Figure 1](#). Output circuitry is fully protected by internal current limit and thermal shut-down, making it rugged and easy to use.

See the [Functional Block Diagram](#) section for a simplified circuit diagram of the BUF634 showing its open-loop complementary follower design.

8.2 Functional Block Diagram

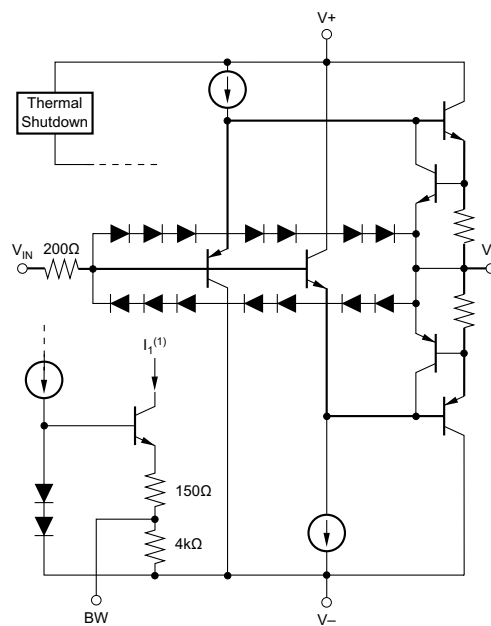

Signal path indicated in bold.
Note: (1) Stage currents are set by I_1 .

8.3 Feature Description

8.3.1 Output Current

The BUF634 device can deliver up to ± 250 -mA continuous output current. Internal circuitry limits output current to approximately ± 350 mA; see [Figure 10](#). For many applications, however, the continuous output current will be limited by thermal effects.

The output voltage swing capability varies with junction temperature and output current (see [Figure 14](#)). Although all four package types are tested for the same output performance using a high speed test, the higher junction temperatures with the DIP and SO-8 package types often provide less output voltage swing. Junction temperature is reduced in the DDPAK surface-mount power package because it is soldered directly to the circuit board. The TO-220 package used with a good heat sink further reduces junction temperature, allowing maximum possible output swing.

8.4 Device Functional Modes

The BUF634 is operational when the power-supply voltage is greater than 4.5 V (± 2.25 V). The maximum power supply voltage for the BUF634 is 36 V (± 18 V). At low power supply conditions, such as ± 2.25 V, the output swing may be limited. Refer to [Electrical Characteristics](#) for additional information.

BUF634

ZHCSJJ0B – SEPTEMBER 2000 – REVISED MARCH 2019

www.ti.com.cn

9 Application and Implementation

NOTE

Information in the following applications sections is not part of the TI component specification, and TI does not warrant its accuracy or completeness. TI's customers are responsible for determining suitability of components for their purposes. Customers should validate and test their design implementation to confirm system functionality.

9.1 Application Information

Figure 19 shows the BUF634 device connected as an open-loop buffer. The source impedance and optional input resistor, R_S , influence frequency response: see [Typical Characteristics](#). Power supplies should be bypassed with capacitors connected close to the device pins. Capacitor values as low as 0.1 μF assure stable operation in most applications, but high output current and fast output slewing can demand large current transients from the power supplies. Solid tantalum 10- μF capacitors are recommended. High frequency open-loop applications may benefit from special bypassing and layout considerations. See [High Frequency Applications](#) for more information.

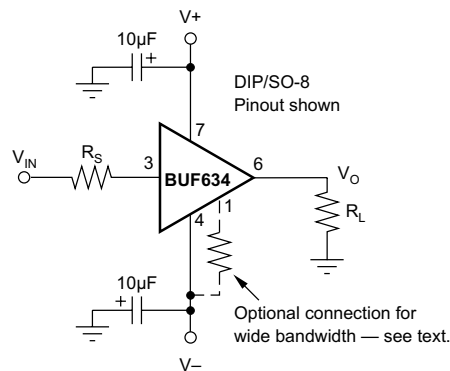

Figure 19. Buffer Connections

9.1.1 High Frequency Applications

The excellent bandwidth and fast slew rate of the BUF634 device are useful in a variety of high frequency open-loop applications. When operated open-loop, printed-circuit-board layout and bypassing technique can affect dynamic performance.

For best results, use a ground plane-type circuit board layout and bypass the power supplies with 0.1- μF ceramic chip capacitors at the device pins in parallel with solid tantalum 10- μF capacitors. Source resistance affects high-frequency peaking, step-response overshoot and ringing. Best response is usually achieved with a series input resistor of 25 Ω to 200 Ω , depending on the signal source. Response with some loads (especially capacitive) can be improved with a resistor of 10 Ω to 150 Ω in series with the output.

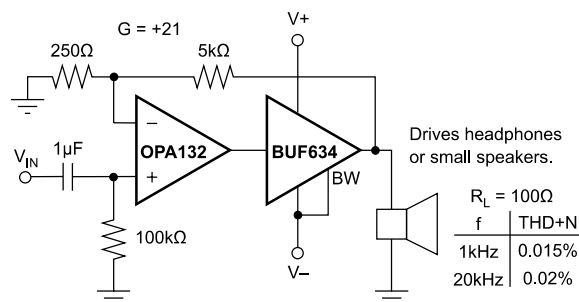

Figure 20. High Performance Headphone Driver

Application Information (continued)

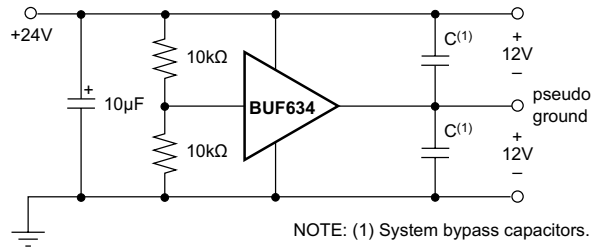

Figure 21. Pseudo-Ground Driver

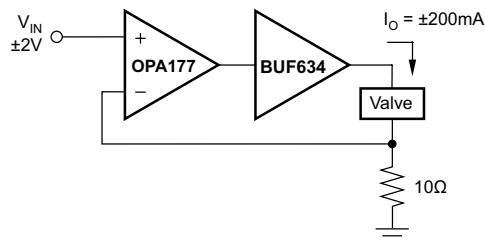

Figure 22. Current-Output Valve Driver

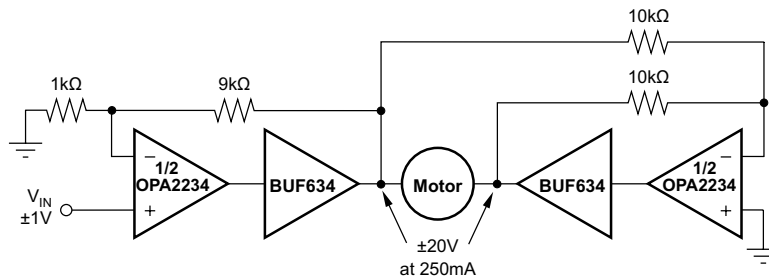

Figure 23. Bridge-Connected Motor Driver

BUF634

ZHCSJJ0B – SEPTEMBER 2000 – REVISED MARCH 2019

www.ti.com.cn

9.2 Typical Application

9.2.1 Boosting Op Amp Output Current

The BUF634 device can be connected inside the feedback loop of most op amps to increase output current (see [Figure 24](#)). When connected inside the feedback loop, the offset voltage of the BUF634 device and other errors are corrected by the feedback of the op amp.

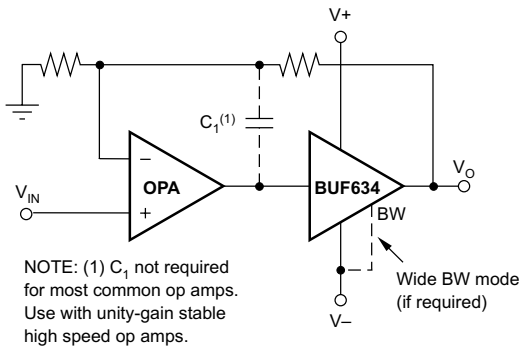

OP AMP	RECOMMENDATIONS
OPA177, OPA1013 OPA111, OPA2111 OPA121, OPA234 ⁽¹⁾ , OPA130 ⁽¹⁾	Use Low I_Q mode. $G = 1$ stable.
OPA27, OPA2107 OPA602, OPA131 ⁽¹⁾	Low I_Q mode is stable. Increasing C_L may cause excessive ringing or instability. Use Wide BW mode.
OPA627, OPA132 ⁽¹⁾	Use Wide BW mode, $C_1 = 200\text{pF}$. $G = 1$ stable.
OPA637, OPA37	Use Wide BW mode. These op amps are not $G = 1$ stable. Use in $G > 4$.

NOTE: (1) Single, dual, and quad versions.

Figure 24. Boosting Op Amp Output Current

9.2.1.1 Design Requirements

- Boost the output current of an OPA627
- Operate from $\pm 15\text{V}$ power supplies
- Operate from -40°C to $+85^\circ\text{C}$
- Gain = 23.5 V/V
- Output current = $\pm 250\text{ mA}$
- Bandwidth greater than 100 kHz

9.2.1.2 Detailed Design Procedure

To assure that the composite amplifier remains stable, the phase shift of the BUF634 device must remain small throughout the loop gain of the circuit. For a $G=+1$ op amp circuit, the BUF634 device must contribute little additional phase shift (approximately 20° or less) at the unity-gain frequency of the op amp. Phase shift is affected by various operating conditions that may affect stability of the op amp; see [Typical Characteristics](#).

Most general-purpose or precision op amps remain unity-gain stable with the BUF634 device connected inside the feedback loop as shown. Large capacitive loads may require the BUF634 device to be connected for wide bandwidth for stable operation. High speed or fast-settling op amps generally require the wide bandwidth mode to remain stable and to assure good dynamic performance. To check for stability with an op amp, look for oscillations or excessive ringing on signal pulses with the intended load, and worst-case conditions that affect phase response of the buffer. Connect the circuit as shown in [Figure 24](#). Choose resistors to provide a voltage gain of 23.5 V/V. Select the feedback resistor to be 2.7 k Ω . Choose the input resistor to be 120 Ω .

Typical Application (continued)

9.2.1.3 Application Curve

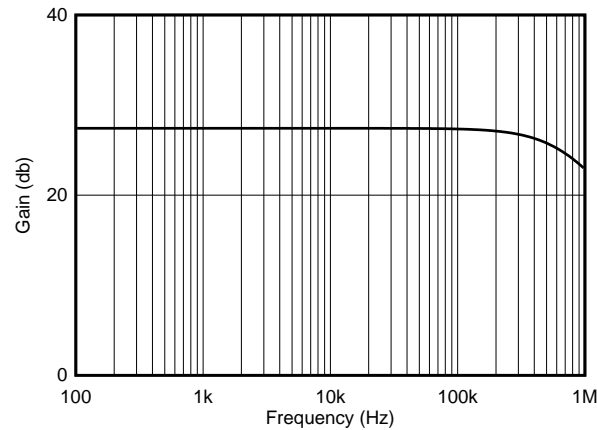

Figure 25. Frequency Response of Composite Amplifier

10 Power Supply Recommendations

The BUF634 is specified for operation from 4.5V to 36 V (± 2.25 V to ± 18 V). Many specifications apply from -40°C to $+85^{\circ}\text{C}$. Parameters that can exhibit significant variance with regard to operating voltage or temperature are presented in the [Typical Characteristics](#).

11 Layout

11.1 Layout Guidelines

For best operational performance of the device, use good PCB layout practices, including:

- Noise can propagate into analog circuitry through the power pins of the circuit. Bypass capacitors are used to reduce the coupled noise by providing low-impedance power sources local to the analog circuitry.
 - Connect low-ESR, 0.1- μF ceramic bypass capacitors between each supply pin and ground, placed as close to the device as possible. A single bypass capacitor from V+ to ground is applicable for single-supply applications.
- Separate grounding for analog and digital portions of circuitry is one of the simplest and most-effective methods of noise suppression. One or more layers on multilayer PCBs are usually devoted to ground planes. A ground plane helps distribute heat and reduces EMI noise pickup. Make sure to physically separate digital and analog grounds paying attention to the flow of the ground current. For more detailed information refer to *Circuit Board Layout Techniques*, [SLOA089](#).
- In order to reduce parasitic coupling, run the input traces as far away from the supply or output traces as possible. If these traces cannot be kept separate, crossing the sensitive trace perpendicular is much better as opposed to in parallel with the noisy trace.
- Place the external components as close to the device as possible. As illustrated in [Figure 27](#)
- Keep the length of input traces as short as possible. Always remember that the input traces are the most sensitive part of the circuit.
- Cleaning the PCB following board assembly is recommended for best performance.
- Any precision integrated circuit may experience performance shifts due to moisture ingress into the plastic package. Following any aqueous PCB cleaning process, baking the PCB assembly is recommended to remove moisture introduced into the device packaging during the cleaning process. A low temperature, post cleaning bake at 85°C for 30 minutes is sufficient for most circumstances.

Layout Guidelines (continued)

Power dissipated in the BUF634 device causes the junction temperature to rise. A thermal protection circuit in the BUF634 device disables the output when the junction temperature reaches approximately 175°C. When the thermal protection is activated, the output stage is disabled, allowing the device to cool. Quiescent current is approximately 6 mA during thermal shutdown. When the junction temperature cools to approximately 165°C, the output circuitry is again enabled. This can cause the protection circuit to cycle on and off with a period ranging from a fraction of a second to several minutes or more, depending on package type, signal, load and thermal environment.

The thermal protection circuit is designed to prevent damage during abnormal conditions. Any tendency to activate the thermal protection circuit during normal operation is a sign of an inadequate heat sink or excessive power dissipation for the package type.

The TO-220 package provides the best thermal performance. When the TO-220 is used with a properly sized heat sink, output is not limited by thermal performance. See Application Bulletin AB-037 for details on heat sink calculations. The DPAK also has excellent thermal characteristics. Its mounting tab should be soldered to a circuit board copper area for good heat dissipation. [Figure 26](#) shows typical thermal resistance from junction to ambient as a function of the copper area. The mounting tab of the TO-220 and DPAK packages is electrically connected to the V– power supply.

The DIP and SO-8 surface-mount packages are excellent for applications requiring high output current with low average power dissipation. To achieve the best possible thermal performance with the DIP or SO-8 packages, solder the device directly to a circuit board. Because much of the heat is dissipated by conduction through the package pins, sockets will degrade thermal performance. Use wide circuit board traces on all the device pins, including pins that are not connected. With the DIP package, use traces on both sides of the printed circuit board if possible.

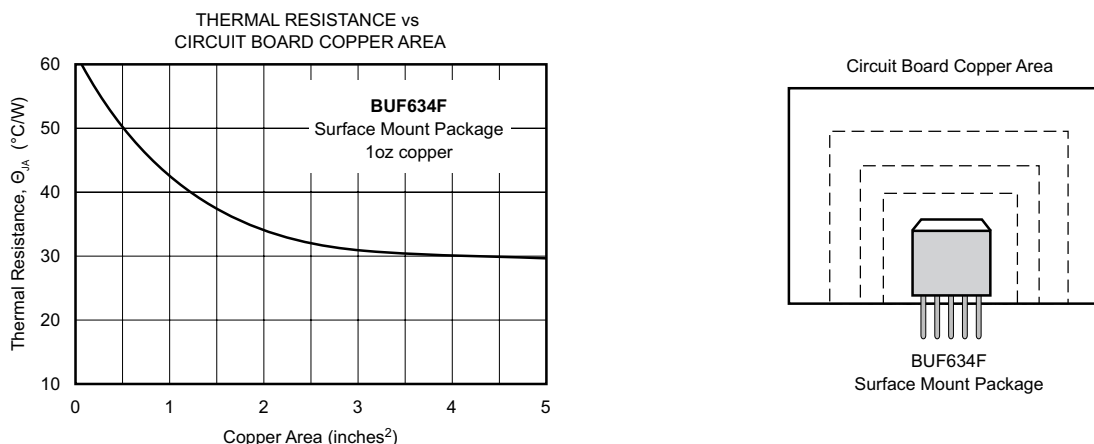

Figure 26. Thermal Resistance vs Circuit Board Copper Area

11.1.1 Power Dissipation

Power dissipation depends on power supply voltage, signal, and load conditions. With DC signals, power dissipation is equal to the product of output current times the voltage across the conducting output transistor, $V_S - V_O$. Power dissipation can be minimized by using the lowest possible power supply voltage necessary to assure the required output voltage swing.

For resistive loads, the maximum power dissipation occurs at a DC output voltage of one-half the power supply voltage. Dissipation with AC signals is lower. Application Bulletin [SBOS022](#) explains how to calculate or measure power dissipation with unusual signals and loads.

Any tendency to activate the thermal protection circuit indicates excessive power dissipation or an inadequate heat sink. For reliable operation, junction temperature should be limited to 150°C, maximum. To estimate the margin of safety in a complete design, increase the ambient temperature until the thermal protection is triggered. The thermal protection should trigger more than 45°C above the maximum expected ambient condition of your application.

11.2 Layout Example

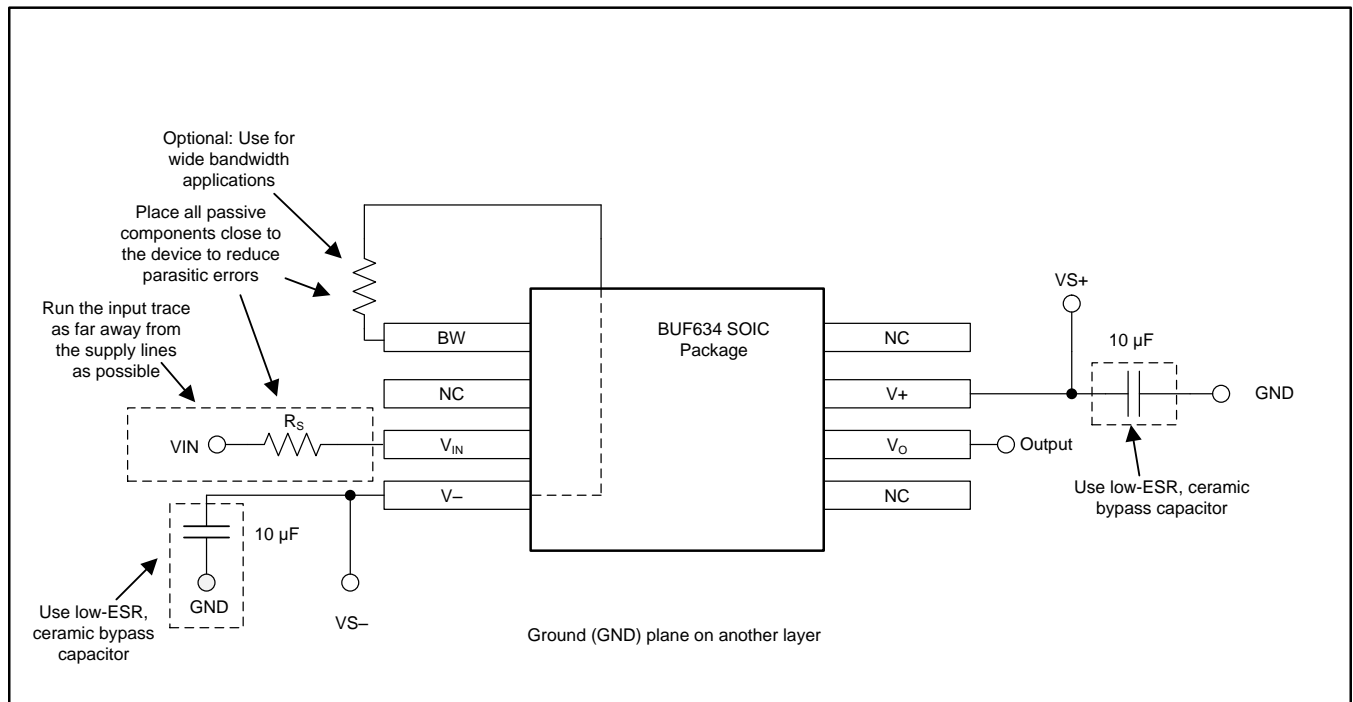

Figure 27. BUF634 Layout Example

12 器件和文档支持

12.1 器件支持

12.1.1 TINA-TI™ (免费软件下载)

TINA™是一款简单、功能强大且易于使用的电路仿真程序，此程序基于 SPICE 引擎。TINA-TI 是 TINA 软件的一款免费全功能版本，除了一系列无源和有源模型外，此版本软件还预先载入了一个宏模型库。TINA-TI 提供所有传统的 SPICE 直流、瞬态和频域分析，以及其他设计功能。

TINA-TI 可从 Analog eLab Design Center (模拟电子实验室设计中心) [免费下载](#)，它提供全面的后续处理能力，使得用户能够以多种方式形成结果。虚拟仪器提供选择输入波形和探测电路节点、电压和波形的功能，从而创建一个动态的快速入门工具。

注

这些文件需要安装 TINA 软件 (由 DesignSoft™提供) 或者 TINA-TI 软件。请从 [TINA-TI 文件夹](#) 中下载免费的 TINA-TI 软件。

12.1.2 TI 高精度设计

BUF634 采用多种 TI 精密设计，有关内容请访问 <http://www.ti.com.cn/>。TI 高精度设计是由 TI 公司高精度模拟应用专家创建的模拟解决方案，提供了许多实用电路的工作原理、组件选择、仿真、完整印刷电路板 (PCB) 电路原理图和布局布线、物料清单以及性能测量结果。

12.2 文档支持

12.2.1 相关文档

请参阅如下相关文档：

- 德州仪器 (TI), [《电路板布局技巧》应用报告](#)
- 德州仪器 (TI), [《组合放大器与 BUF634》应用手册](#)
- 德州仪器 (TI), [《向 BUF634 添加电流限制》应用手册](#)
- 德州仪器 (TI), [《功率放大器应力和功率处理限制》应用手册](#)
- 德州仪器 (TI), [《无铅成品组件的储存寿命评估》应用报告](#)

12.3 接收文档更新通知

要接收文档更新通知，请导航至 [Ti.com.cn](http://www.ti.com.cn) 上的器件产品文件夹。单击右上角的 [通知我](#) 进行注册，即可每周接收产品信息更改摘要。有关更改的详细信息，请查看任何已修订文档中包含的修订历史记录。

12.4 社区资源

下列链接提供到 TI 社区资源的连接。链接的内容由各个分销商“按照原样”提供。这些内容并不构成 TI 技术规范，并且不一定反映 TI 的观点；请参阅 TI 的 [《使用条款》](#)。

TI E2E™ Online Community *TI's Engineer-to-Engineer (E2E) Community*. Created to foster collaboration among engineers. At e2e.ti.com, you can ask questions, share knowledge, explore ideas and help solve problems with fellow engineers.

Design Support *TI's Design Support* Quickly find helpful E2E forums along with design support tools and contact information for technical support.

12.5 商标

E2E is a trademark of Texas Instruments.

TINA-TI is a trademark of Texas Instruments, Inc and DesignSoft, Inc.

TINA, DesignSoft are trademarks of DesignSoft, Inc.

All other trademarks are the property of their respective owners.

12.6 静电放电警告



ESD 可能会损坏该集成电路。德州仪器 (TI) 建议通过适当的预防措施处理所有集成电路。如果不遵守正确的处理措施和安装程序，可能会损坏集成电路。

ESD 的损坏小至导致微小的性能降级，大至整个器件故障。精密的集成电路可能更容易受到损坏，这是因为非常细微的参数更改都可能会导致器件与其发布的规格不相符。

12.7 术语表

[SLYZ022](#) — TI 术语表。

这份术语表列出并解释术语、缩写和定义。

13 机械、封装和可订购信息

以下页面包含机械、封装和可订购信息。这些信息是指定器件的最新可用数据。数据如有变更，恕不另行通知，且不会对此文档进行修订。如需获取此数据表的浏览器版本，请查阅左侧的导航栏。

PACKAGING INFORMATION

Orderable Device	Status (1)	Package Type	Package Drawing	Pins	Package Qty	Eco Plan (2)	Lead finish/ Ball material (6)	MSL Peak Temp (3)	Op Temp (°C)	Device Marking (4/5)	Samples
BUF634F/500	NRND	DDPAK/ TO-263	KTT	5	500	RoHS & Green	SN	Level-2-260C-1 YEAR	-40 to 125	BUF634F	
BUF634F/500E3	NRND	DDPAK/ TO-263	KTT	5	500	RoHS & Green	SN	Level-2-260C-1 YEAR	-40 to 125	BUF634F	
BUF634FKTTT	NRND	DDPAK/ TO-263	KTT	5	250	RoHS & Green	SN	Level-2-260C-1 YEAR	-40 to 125	BUF634F	
BUF634FKTTTE3	NRND	DDPAK/ TO-263	KTT	5	250	RoHS & Green	SN	Level-2-260C-1 YEAR	-40 to 125	BUF634F	
BUF634T	NRND	TO-220	KC	5	49	RoHS & Green	Call TI SN	N / A for Pkg Type	-40 to 125	BUF634T	
BUF634TG3	NRND	TO-220	KC	5	49	RoHS & Green	SN	N / A for Pkg Type	-40 to 125	BUF634T	
BUF634U	NRND	SOIC	D	8	75	RoHS & Green	NIPDAU	Level-3-260C-168 HR	-40 to 125	BUF 634U	
BUF634U/2K5	NRND	SOIC	D	8	2500	RoHS & Green	NIPDAU	Level-3-260C-168 HR	-40 to 125	BUF 634U	

(1) The marketing status values are defined as follows:

ACTIVE: Product device recommended for new designs.

LIFEBUY: TI has announced that the device will be discontinued, and a lifetime-buy period is in effect.

NRND: Not recommended for new designs. Device is in production to support existing customers, but TI does not recommend using this part in a new design.

PREVIEW: Device has been announced but is not in production. Samples may or may not be available.

OBSELETE: TI has discontinued the production of the device.

(2) **RoHS:** TI defines "RoHS" to mean semiconductor products that are compliant with the current EU RoHS requirements for all 10 RoHS substances, including the requirement that RoHS substance do not exceed 0.1% by weight in homogeneous materials. Where designed to be soldered at high temperatures, "RoHS" products are suitable for use in specified lead-free processes. TI may reference these types of products as "Pb-Free".

RoHS Exempt: TI defines "RoHS Exempt" to mean products that contain lead but are compliant with EU RoHS pursuant to a specific EU RoHS exemption.

Green: TI defines "Green" to mean the content of Chlorine (Cl) and Bromine (Br) based flame retardants meet JS709B low halogen requirements of <=1000ppm threshold. Antimony trioxide based flame retardants must also meet the <=1000ppm threshold requirement.

(3) MSL, Peak Temp. - The Moisture Sensitivity Level rating according to the JEDEC industry standard classifications, and peak solder temperature.

(4) There may be additional marking, which relates to the logo, the lot trace code information, or the environmental category on the device.

⁽⁵⁾ Multiple Device Markings will be inside parentheses. Only one Device Marking contained in parentheses and separated by a "~" will appear on a device. If a line is indented then it is a continuation of the previous line and the two combined represent the entire Device Marking for that device.

⁽⁶⁾ Lead finish/Ball material - Orderable Devices may have multiple material finish options. Finish options are separated by a vertical ruled line. Lead finish/Ball material values may wrap to two lines if the finish value exceeds the maximum column width.

Important Information and Disclaimer:The information provided on this page represents TI's knowledge and belief as of the date that it is provided. TI bases its knowledge and belief on information provided by third parties, and makes no representation or warranty as to the accuracy of such information. Efforts are underway to better integrate information from third parties. TI has taken and continues to take reasonable steps to provide representative and accurate information but may not have conducted destructive testing or chemical analysis on incoming materials and chemicals. TI and TI suppliers consider certain information to be proprietary, and thus CAS numbers and other limited information may not be available for release.

In no event shall TI's liability arising out of such information exceed the total purchase price of the TI part(s) at issue in this document sold by TI to Customer on an annual basis.

TAPE AND REEL INFORMATION

QUADRANT ASSIGNMENTS FOR PIN 1 ORIENTATION IN TAPE

*All dimensions are nominal

Device	Package Type	Package Drawing	Pins	SPQ	Reel Diameter (mm)	Reel Width W1 (mm)	A0 (mm)	B0 (mm)	K0 (mm)	P1 (mm)	W (mm)	Pin1 Quadrant
BUF634U/2K5	SOIC	D	8	2500	330.0	12.4	6.4	5.2	2.1	8.0	12.0	Q1

TAPE AND REEL BOX DIMENSIONS

*All dimensions are nominal

Device	Package Type	Package Drawing	Pins	SPQ	Length (mm)	Width (mm)	Height (mm)
BUF634U/2K5	SOIC	D	8	2500	367.0	367.0	35.0

TUBE

*All dimensions are nominal

Device	Package Name	Package Type	Pins	SPQ	L (mm)	W (mm)	T (μm)	B (mm)
BUF634T	KC	TO-220	5	49	546	31	11930	3.17
BUF634TG3	KC	TO-220	5	49	546	31	11930	3.17
BUF634U	D	SOIC	8	75	506.6	8	3940	4.32



D0008A

PACKAGE OUTLINE

SOIC - 1.75 mm max height

SMALL OUTLINE INTEGRATED CIRCUIT



4214825/C 02/2019

NOTES:

- Linear dimensions are in inches [millimeters]. Dimensions in parenthesis are for reference only. Controlling dimensions are in inches. Dimensioning and tolerancing per ASME Y14.5M.
- This drawing is subject to change without notice.
- This dimension does not include mold flash, protrusions, or gate burrs. Mold flash, protrusions, or gate burrs shall not exceed $.006$ [0.15] per side.
- This dimension does not include interlead flash.
- Reference JEDEC registration MS-012, variation AA.

EXAMPLE BOARD LAYOUT

D0008A

SOIC - 1.75 mm max height

SMALL OUTLINE INTEGRATED CIRCUIT



LAND PATTERN EXAMPLE
EXPOSED METAL SHOWN
SCALE:8X



SOLDER MASK DETAILS

4214825/C 02/2019

NOTES: (continued)

6. Publication IPC-7351 may have alternate designs.

7. Solder mask tolerances between and around signal pads can vary based on board fabrication site.

EXAMPLE STENCIL DESIGN

D0008A

SOIC - 1.75 mm max height

SMALL OUTLINE INTEGRATED CIRCUIT



SOLDER PASTE EXAMPLE
BASED ON .005 INCH [0.125 MM] THICK STENCIL
SCALE:8X

4214825/C 02/2019

NOTES: (continued)

8. Laser cutting apertures with trapezoidal walls and rounded corners may offer better paste release. IPC-7525 may have alternate design recommendations.
9. Board assembly site may have different recommendations for stencil design.

KC0005A



PACKAGE OUTLINE

TO-220 - 16.51 mm max height

TO-220

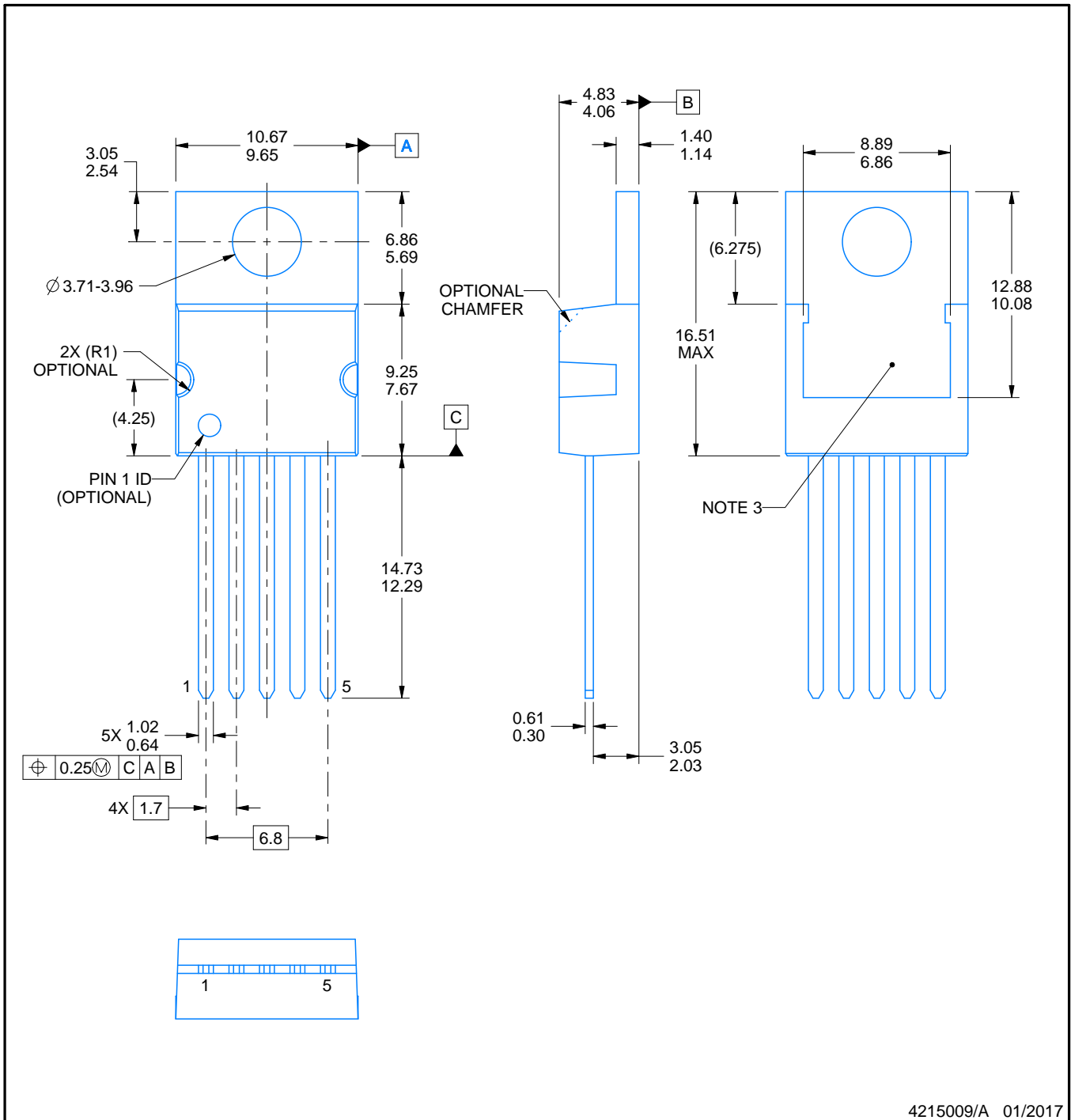

4215009/A 01/2017

NOTES:

1. All controlling linear dimensions are in inches. Dimensions in brackets are in millimeters. Any dimension in brackets or parenthesis are for reference only. Dimensioning and tolerancing per ASME Y14.5M.
2. This drawing is subject to change without notice.
3. Shape may vary per different assembly sites.

EXAMPLE BOARD LAYOUT

KC0005A

TO-220 - 16.51 mm max height

TO-220

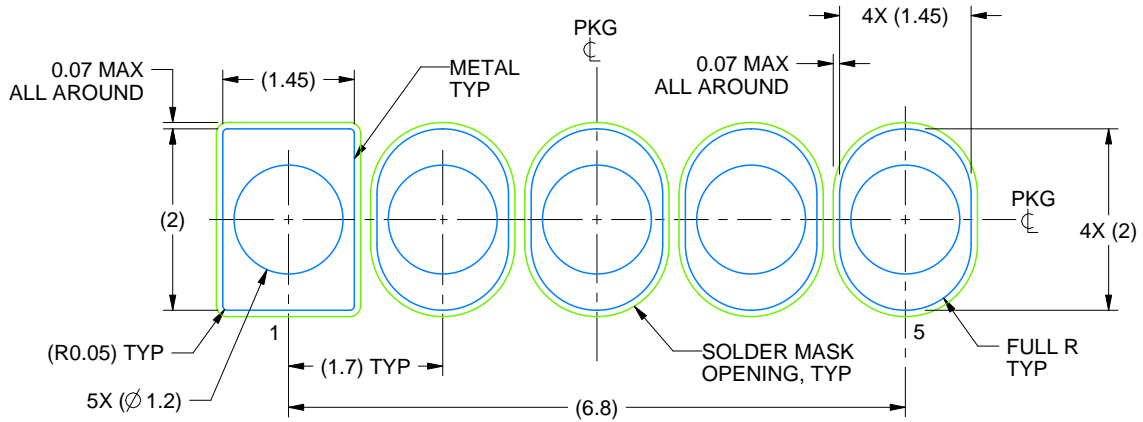

LAND PATTERN
NON-SOLDER MASK DEFINED
SCALE:12X

4215009/A 01/2017

KTT (R-PSFM-G5)

PLASTIC FLANGE-MOUNT PACKAGE



4200577-4/G 01/13

- NOTES:
- A. All linear dimensions are in millimeters.
 - B. This drawing is subject to change without notice.
 - C. Body dimensions do not include mold flash or protrusion. Mold flash or protrusion not to exceed 0.005 (0,13) per side.
-  Falls within JEDEC TO-263 variation BA, except minimum lead thickness, maximum seating height, and minimum body length.

KTT (R-PSFM-G5)

PLASTIC FLANGE-MOUNT PACKAGE

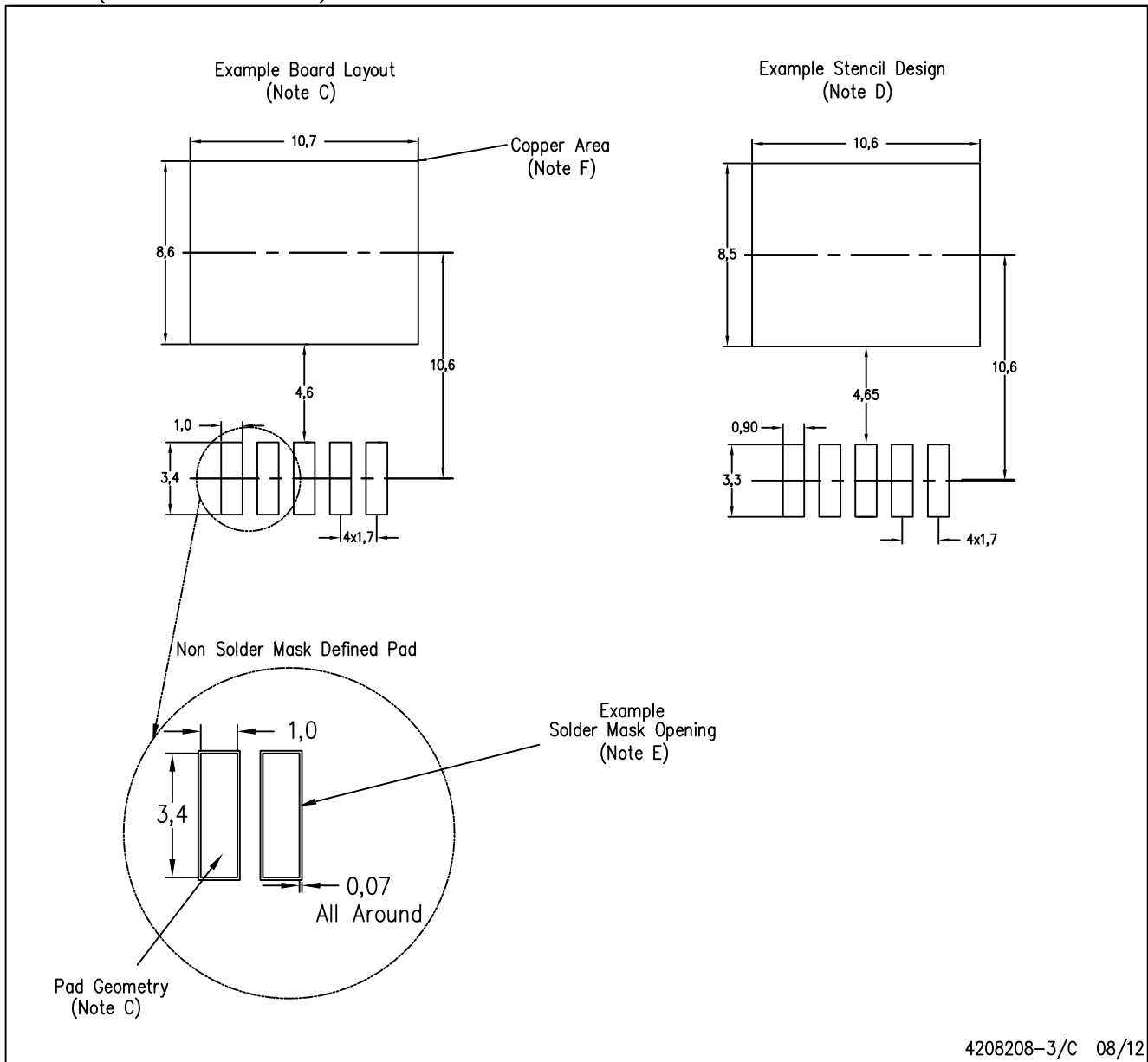

4208208-3/C 08/12

- NOTES:
- All linear dimensions are in millimeters.
 - This drawing is subject to change without notice.
 - Publication IPC-SM-782 is recommended for alternate designs.
 - Laser cutting apertures with trapezoidal walls and also rounding corners will offer better paste release. Customers should contact their board assembly site for stencil design recommendations. Refer to IPC-7525.
 - Customers should contact their board fabrication site for solder mask tolerances between and around signal pads.
 - This package is designed to be soldered to a thermal pad on the board. Refer to the Product Datasheet for specific thermal information, via requirements, and recommended thermal pad size. For thermal pad sizes larger than shown a solder mask defined pad is recommended in order to maintain the solderable pad geometry while increasing copper area.

重要声明和免责声明

TI“按原样”提供技术和可靠性数据（包括数据表）、设计资源（包括参考设计）、应用或其他设计建议、网络工具、安全信息和其他资源，不保证没有瑕疵且不做任何明示或暗示的担保，包括但不限于对适销性、某特定用途方面的适用性或不侵犯任何第三方知识产权的暗示担保。

这些资源可供使用 TI 产品进行设计的熟练开发人员使用。您将自行承担以下全部责任：(1) 针对您的应用选择合适的 TI 产品，(2) 设计、验证并测试您的应用，(3) 确保您的应用满足相应标准以及任何其他功能安全、信息安全、监管或其他要求。

这些资源如有变更，恕不另行通知。TI 授权您仅可将这些资源用于研发本资源所述的 TI 产品的应用。严禁对这些资源进行其他复制或展示。您无权使用任何其他 TI 知识产权或任何第三方知识产权。您应全额赔偿因在这些资源的使用中对 TI 及其代表造成的任何索赔、损害、成本、损失和债务，TI 对此概不负责。

TI 提供的产品受 [TI 的销售条款](#) 或 [ti.com](#) 上其他适用条款/TI 产品随附的其他适用条款的约束。TI 提供这些资源并不会扩展或以其他方式更改 TI 针对 TI 产品发布的适用的担保或担保免责声明。

TI 反对并拒绝您可能提出的任何其他或不同的条款。

邮寄地址：Texas Instruments, Post Office Box 655303, Dallas, Texas 75265

Copyright © 2023，德州仪器 (TI) 公司