

省电型流控螺线管驱动器

 查询样品: **DRV120**

特性

- 用于控制螺线管电流的带有脉宽调制 (PWM) 的集成金属氧化物半导体场效应晶体管 (MOSFET)
 - 用于调节螺线管电流的外部感测电阻器
- 螺线管电流的快速斜升以保证激活
- 在保持模式中, 为了实现低功耗和热耗散, 螺线管电流被减少
- 可外部设定峰值电流、峰值电流的保持时间、保持电流和 PWM 时钟频率。它们还可以在无需外部组件的情况下在标称值上运行。
- 内部电源电压调节
 - 高达 **28V** 的外部电源电压
- 保护
 - 热关断
 - 欠压闭锁 (UVLO)
 - 最大斜升时间
 - 可选状态 (STATUS) 输出
- 运行温度范围: **-40°C 至 105°C**
- **8 引脚**和 **14 引脚** 薄型小外形尺寸 (TSSOP) 封装选项

应用范围

- 电动机械驱动器: 螺线管、阀门、继电器
- 大型家用电器、太阳能、运输

说明

DRV120 是一款针对螺线管的 PWM 电流驱动器。它被设计成使用控制良好的电流来调节电流以确保激活并同时减少功率耗散。螺线管电流快速斜升以确保阀门或者继电器的打开。在最初的斜升后, 螺线管电流被保持在峰值以确保正确运行, 这之后, 为了避免过热问题并减少功率耗散, 这个电流被减少至较低的保持水平。

使用一个外部电容器对峰值电流的持续时间进行设定。电流斜波峰值和保持电平、以及 PWM 频率可由外部电阻器独立设定。如果针对相应参数的默认值适用于应用的话, 外部设置电阻器也可被省略。

DRV120 可由 6V 至 28V 的外部电源供电运行。

ORDERING INFORMATION⁽¹⁾

| PACKAGE ⁽²⁾ | | ORDERABLE PART NUMBER | TOP-SIDE MARKING |
|------------------------|--------------|-----------------------|------------------|
| (TSSOP-8) - PW | Reel of 2000 | DRV120PWR | 120 |
| (TSSOP-14) - PW | Reel of 2000 | DRV120APWR | 120A |

(1) For the most current packaging and ordering information, see the Package Option Addendum at the end of this document, or see the TI web site at www.ti.com.

(2) Package drawings, thermal data, and symbolization are available at www.ti.com/packaging.



Please be aware that an important notice concerning availability, standard warranty, and use in critical applications of Texas Instruments semiconductor products and disclaimers thereto appears at the end of this data sheet.

TYPICAL APPLICATION

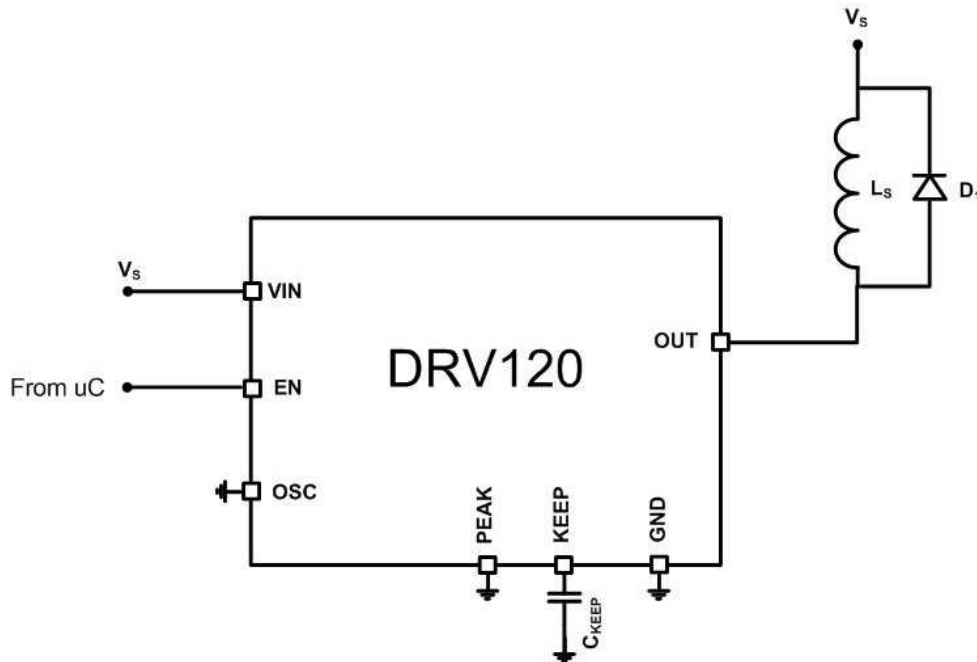

Figure 1. Default Configuration With 8-Pin TSSOP Option

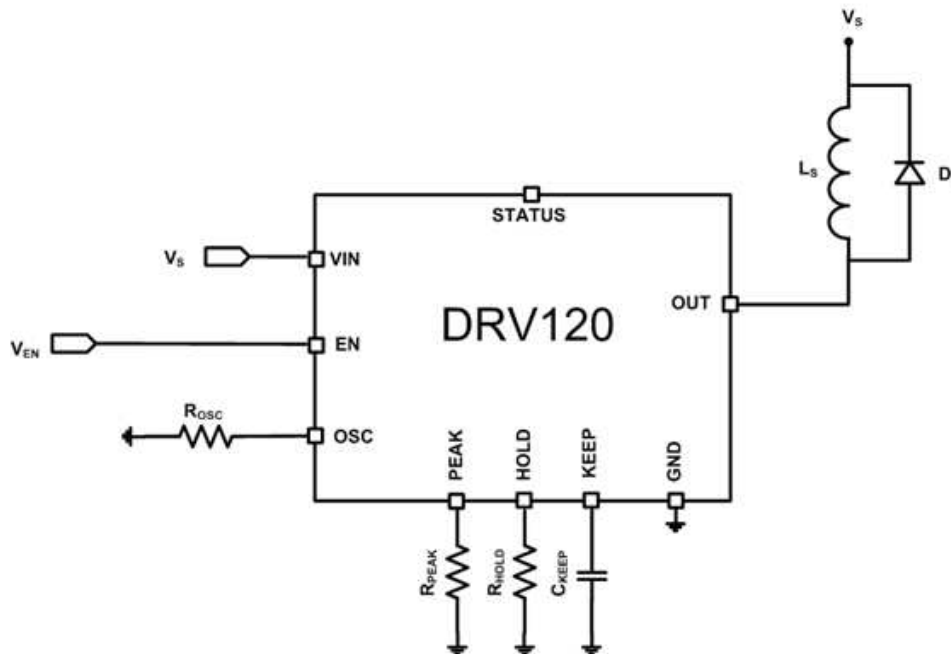

Figure 2. External Parameter Setting for 14-Pin TSSOP Option

DEVICE INFORMATION
Functional Block Diagram

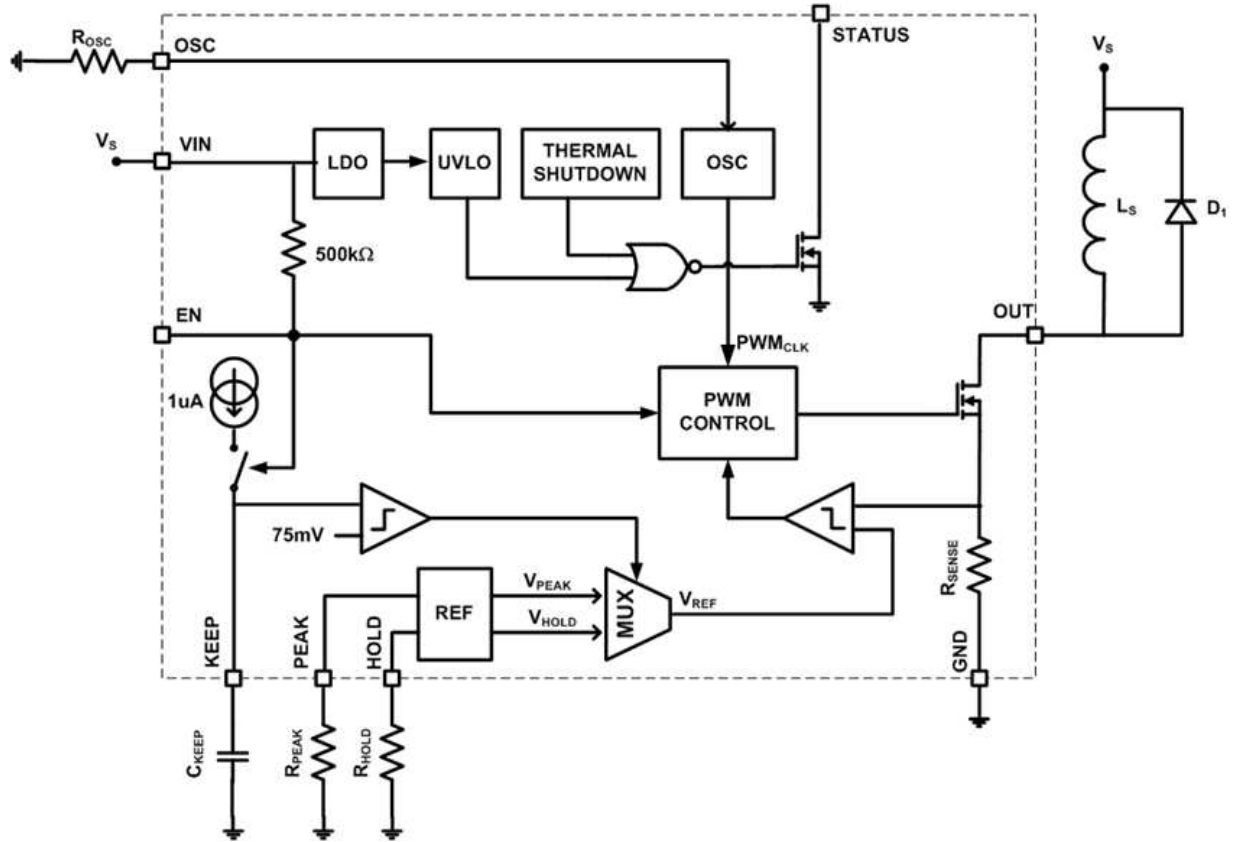
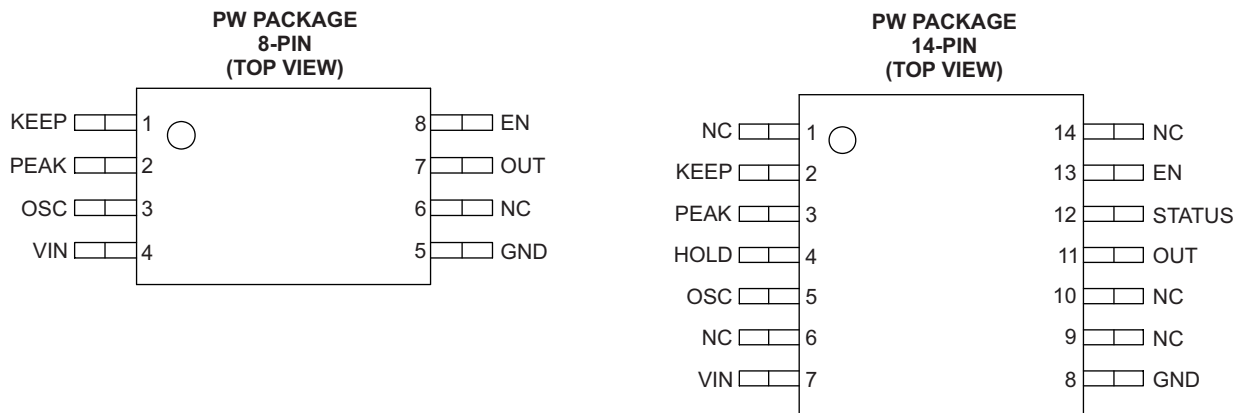

Table 1. TERMINAL FUNCTIONS

| NAME | PIN (8-PIN PW) ⁽¹⁾ | PIN (14-PIN PW) | DESCRIPTION |
|--------|-------------------------------|-----------------|----------------------------|
| NC | 6 | 1, 6, 9, 10, 14 | No connect |
| KEEP | 1 | 2 | Keep time set |
| PEAK | 2 | 3 | Peak current set |
| HOLD | - | 4 | Hold current set |
| OSC | 3 | 5 | PWM frequency set |
| VIN | 4 | 7 | 6-V to 28-V supply |
| GND | 5 | 8 | Ground |
| OUT | 7 | 11 | Controlled current sink |
| STATUS | - | 12 | Open drain fault indicator |
| EN | 8 | 13 | Enable |

(1) In the 8-pin package, the HOLD pin is not bonded out. For this package, the HOLD mode is configured to default (internal) settings.



ABSOLUTE MAXIMUM RATINGS⁽¹⁾⁽²⁾

| | | VALUE | UNIT |
|------------------|---|------------|------|
| V _{IN} | Input voltage range | -0.3 to 28 | V |
| | Voltage range on EN, STATUS, PEAK, HOLD, OSC, SENSE, RAMP | -0.3 to 7 | V |
| | Voltage range on OUT | -0.3 to 28 | V |
| ESD rating | HBM (human body model) | 2000 | V |
| | CDM (charged device model) | 500 | |
| T _J | Operating virtual junction temperature range | -40 to 125 | °C |
| T _{stg} | Storage temperature range | -65 to 150 | °C |

- (1) Stresses beyond those listed under absolute maximum ratings may cause permanent damage to the device. These are stress ratings only, and functional operation of the device at these or any other conditions beyond those indicated under recommended operating conditions is not implied. Exposure to absolute-maximum-rated conditions for extended periods may affect device reliability.
- (2) All voltage values are with respect to network ground terminal.

RECOMMENDED OPERATING CONDITIONS

over operating free-air temperature range (unless otherwise noted)

| | | MIN | NOM | MAX | UNIT |
|------------------|-------------------------------|-----|-----|-----|------|
| I _{OUT} | Average solenoid DC current | | | 125 | mA |
| V _{IN} | Supply voltage | 6 | 12 | 26 | V |
| C _{IN} | Input capacitor | 1 | 4.7 | | μF |
| L | Solenoid inductance | | 1 | | H |
| T _A | Operating ambient temperature | -40 | | 105 | °C |

THERMAL INFORMATION

| THERMAL METRIC | | DRV120 | DRV120 | UNITS |
|--------------------|---|--------|---------|-------|
| | | PW | PW | |
| | | 8 PINS | 14 PINS | |
| θ _{JA} | Junction-to-ambient thermal resistance ⁽¹⁾ | 183.8 | 122.6 | °C/W |
| θ _{JCtop} | Junction-to-case (top) thermal resistance ⁽²⁾ | 69.2 | 51.2 | |
| θ _{JB} | Junction-to-board thermal resistance ⁽³⁾ | 112.6 | 64.3 | |
| ψ _{JT} | Junction-to-top characterization parameter ⁽⁴⁾ | 10.4 | 6.5 | |
| ψ _{JB} | Junction-to-board characterization parameter ⁽⁵⁾ | 110.9 | 63.7 | |
| θ _{JCbot} | Junction-to-case (bottom) thermal resistance ⁽⁶⁾ | N/A | N/A | |

- (1) 在 JESD51-2a 描述的环境中，按照 JESD51-7 的指定，在一个 JEDEC 标准高 K 电路板上进行仿真，从而获得自然对流条件下的结至环境热阻。
- (2) 通过在封装顶部模拟一个冷板测试来获得结至芯片外壳（顶部）的热阻。不存在特定的 JEDEC 标准测试，但可在 ANSI SEMI 标准 G30-88 中找到内容接近的说明。
- (3) 按照 JESD51-8 中的说明，通过在配有用于控制 PCB 温度的环形冷板夹具的环境中进行仿真，以获得结板热阻。
- (4) 结至顶部特征参数，ψ_{JT}，估算真实系统中器件的结温，并使用 JESD51-2a（第 6 章和第 7 章）中描述的程序从仿真数据中提取出该参数以便获得 θ_{JA}。
- (5) 结至电路板特征参数，ψ_{JB}，估算真实系统中器件的结温，并使用 JESD51-2a（第 6 章和第 7 章）中描述的程序从仿真数据中提取出该参数以便获得 θ_{JA}。
- (6) 通过在外露（电源）焊盘上进行冷板测试仿真来获得结至芯片外壳（底部）热阻。不存在特定的 JEDEC 标准测试，但可在 ANSI SEMI 标准 G30-88 中找到内容接近的说明。

ELECTRICAL CHARACTERISTICS

$V_{IN} = 14\text{ V}$, $T_A = -40^\circ\text{C}$ to 105°C , over operating free-air temperature range (unless otherwise noted)

| PARAMETER | | TEST CONDITIONS | MIN | TYP | MAX | UNIT |
|--|--|---|------|-----|-----|------------------|
| SUPPLY | | | | | | |
| I_Q | Standby current | EN = 0, $V_{IN} = 14\text{ V}$ | | 100 | 150 | μA |
| | Quiescent current | EN = 1, $V_{IN} = 14\text{ V}$ | | 300 | 400 | |
| CURRENT DRIVER | | | | | | |
| R_{OUT} | OUT to GND resistance | $I_{OUT} = 200\text{ mA}$ | | 1.7 | 2.5 | Ω |
| f_{PWM} | PWM frequency | OSC = GND | 15 | 20 | 25 | kHz |
| D_{MAX} | Maximum PWM duty cycle | | | 100 | | % |
| D_{MIN} | Minimum PWM duty cycle | | | 9 | | % |
| t_D | Start-up delay | Delay between EN going high until driver enabled ⁽¹⁾ , $f_{PWM} = 20\text{ kHz}$ | | 25 | 50 | μs |
| CURRENT CONTROLLER, INTERNAL SETTINGS | | | | | | |
| I_{PEAK} | Peak current | PEAK = GND | 160 | 200 | 240 | mA |
| I_{HOLD} | Hold current | HOLD = GND | 40 | 50 | 60 | mA |
| CURRENT CONTROLLER, EXTERNAL SETTINGS | | | | | | |
| $t_{KEEP}^{(2)}$ | Externally set keep time at peak current | $C_{KEEP} = 1\ \mu\text{F}$ | | 75 | | ms |
| I_{PEAK} | Externally set peak current | $R_{PEAK} = 50\text{ k}\Omega$ | | 250 | | mA |
| | | $R_{PEAK} = 200\text{ k}\Omega$ | | 83 | | |
| I_{HOLD} | Externally set hold current | $R_{HOLD} = 50\text{ k}\Omega$ | | 100 | | mA |
| | | $R_{HOLD} = 200\text{ k}\Omega$ | | 33 | | |
| f_{PWM} | Externally set PWM frequency | $R_{OSC} = 50\text{ k}\Omega$ | | 60 | | kHz |
| | | $R_{OSC} = 200\text{ k}\Omega$ | | 20 | | |
| LOGIC INPUT LEVELS (EN) | | | | | | |
| V_{IL} | Input low level | | | | 1.3 | V |
| V_{IH} | Input high level | | 1.65 | | | V |
| R_{EN} | Input pull-up resistance | | 350 | 500 | | k Ω |
| LOGIC OUTPUT LEVELS (STATUS) | | | | | | |
| V_{OL} | Output low level | Pull-down activated, $I_{STATUS} = 2\text{ mA}$ | | | 0.3 | V |
| I_{IL} | Output leakage current | Pull-down deactivated, $V(\text{STATUS}) = 5\text{ V}$ | | | 1 | μA |
| UNDERVOLTAGE LOCKOUT | | | | | | |
| V_{UVLO} | Undervoltage lockout threshold | | | 4.6 | | V |
| THERMAL SHUTDOWN | | | | | | |
| T_{TSD} | Junction temperature shutdown threshold | | | 160 | | $^\circ\text{C}$ |
| T_{TSU} | Junction temperature startup threshold | | | 140 | | $^\circ\text{C}$ |

(1) Logic HIGH between 4 V and 7 V. Note: absolute max voltage rating is 7 V.

(2) Either internal or external t_{KEEP} time setting is selected to be activated during manufacturing of production version of DRV120.

FUNCTIONAL DESCRIPTION

DRV120 controls the current through the solenoid as shown in [Figure 3](#). Activation starts when EN pin voltage is pulled high either by an external driver or internal pull-up. In the beginning of activation, DRV120 allows the load current to ramp up to the peak value I_{PEAK} and it regulates it at the peak value for the time, t_{KEEP} , before reducing it to I_{HOLD} . The load current is regulated at the hold value as long as the EN pin is kept high. The initial current ramp-up time depends on the inductance and resistance of the solenoid. Once EN pin is driven to GND, DRV120 allows the solenoid current to decay to zero.

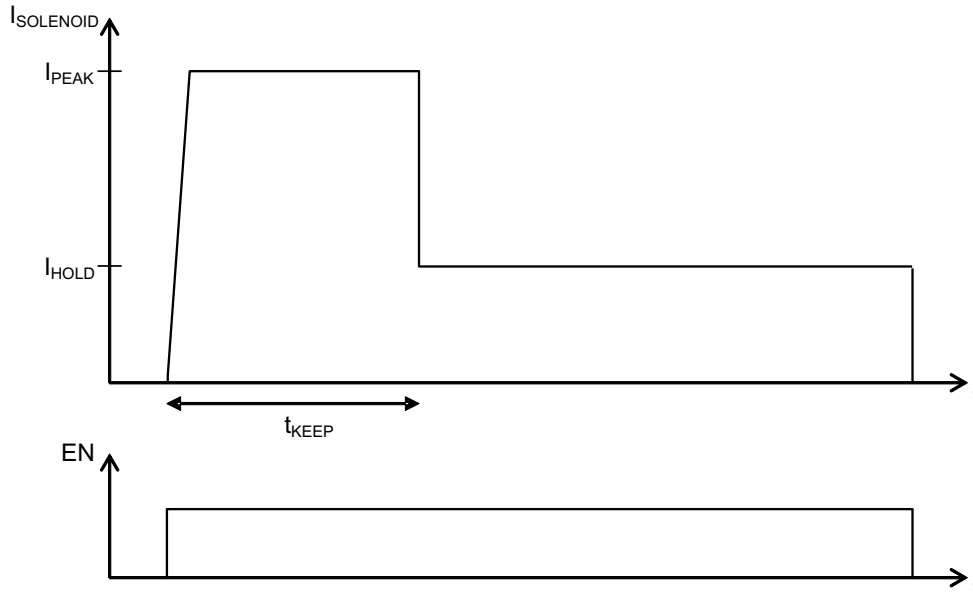

Figure 3. Typical Current Waveform Through the Solenoid

t_{KEEP} is set externally by connecting a capacitor to the KEEP pin. A constant current is sourced from the KEEP pin that is driven into an external capacitor resulting in a linear voltage ramp. When the KEEP pin voltage reaches 75 mV, the current regulation reference voltage, V_{REF} , is switched from V_{PEAK} to V_{HOLD} . Dependency of t_{KEEP} from the external capacitor size can be calculated by:

$$t_{KEEP} [s] = C_{KEEP} [F] \cdot 75 \cdot 10^3 \left[\frac{s}{F} \right] \quad (1)$$

The current control loop regulates, cycle-by-cycle, the solenoid current by using an internal current sensing resistor and MOSFET switch. During the ON-cycle, current flows from OUT pin to GND pin through the internal switch as long as voltage over current sensing resistor is less than V_{REF} . As soon as the current sensing voltage is above V_{REF} , the internal switch is immediately turned off until the next ON-cycle is triggered by the internal PWM clock signal. In the beginning of each ON-cycle, the internal switch is turned on and stays on for at least the time determined by the minimum PWM signal duty cycle, D_{MIN} .

I_{PEAK} and I_{HOLD} depend on fixed resistance values R_{PEAK} and R_{HOLD} as shown in [Figure 4](#). If the PEAK pin is connected to ground or if R_{PEAK} is below 33.33 k Ω (typ value), then I_{PEAK} is at its default value (internal setting). The I_{PEAK} value can alternatively be set by connecting an external resistor to ground from the PEAK pin. For example, if a 50-k Ω ($= R_{PEAK}$) resistor is connected between PEAK and GND, then the externally set I_{PEAK} level will be 250 mA. If $R_{PEAK} = 200$ k Ω is, then the externally set I_{PEAK} level will be 83 mA. HOLD current external setting, I_{HOLD} , works in the same way, but current levels are 40% of the I_{PEAK} . External settings for I_{PEAK} and I_{HOLD} are independent of each other. I_{PEAK} and I_{HOLD} values can be calculated by using the formula below.

$$I_{PEAK} = \frac{250mA}{R_{PEAK}} \cdot 66.67k\Omega; 66.67k\Omega < R_{PEAK} < 550k\Omega \quad (2)$$

$$I_{HOLD} = \frac{100mA}{R_{HOLD}} \cdot 66.67k\Omega; 66.67k\Omega < R_{HOLD} < 250k\Omega \quad (3)$$

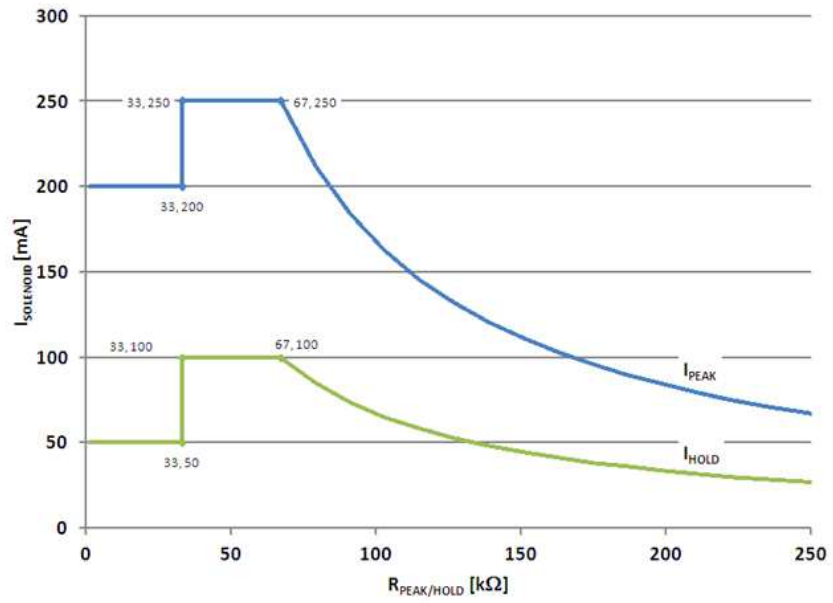

Figure 4. PEAK and HOLD Mode Current Settings

Frequency of the internal PWM clock signal, PWM_{CLK} , that triggers each ON-cycle can be adjusted by external resistor, R_{OSC} , connected between OSC and GND. Frequency as a function of resistor value is shown in Figure 5. Default frequency is used when OSC is connected to GND directly. PWM frequency as a function of external fixed adjustment resistor value (greater than 66.67 k Ω) is given below.

$$f_{PWM} = \frac{60kHz}{R_{OSC}} \cdot 66.67k\Omega; 66.67k\Omega < R_{OSC} < 2M\Omega \quad (4)$$

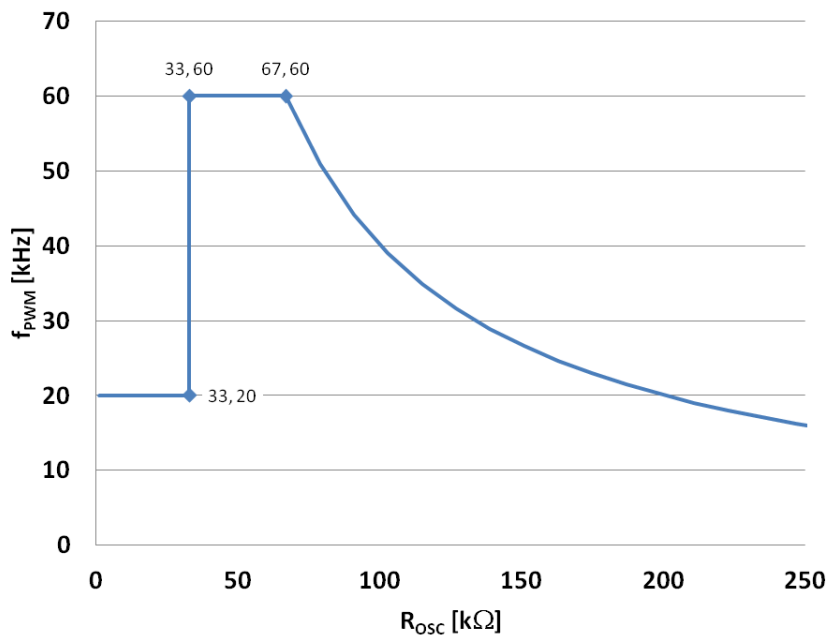

Figure 5. PWM Clock Frequency Setting

Open-drain STATUS output is deactivated if either under voltage lockout or thermal shutdown blocks have triggered.

PACKAGING INFORMATION

| Orderable Device | Status (1) | Package Type | Package Drawing | Pins | Package Qty | Eco Plan (2) | Lead finish/ Ball material (6) | MSL Peak Temp (3) | Op Temp (°C) | Device Marking (4/5) | Samples |
|------------------|---------------|--------------|--------------------|------|----------------|-----------------|--------------------------------------|----------------------|--------------|-------------------------|-------------------------|
| DRV120APWR | ACTIVE | TSSOP | PW | 14 | 2000 | RoHS & Green | NIPDAU | Level-2-260C-1 YEAR | -40 to 105 | 120A | Samples |
| DRV120PWR | ACTIVE | TSSOP | PW | 8 | 2000 | RoHS & Green | NIPDAU | Level-2-260C-1 YEAR | -40 to 105 | 120 | Samples |

(1) The marketing status values are defined as follows:

ACTIVE: Product device recommended for new designs.

LIFEBUY: TI has announced that the device will be discontinued, and a lifetime-buy period is in effect.

NRND: Not recommended for new designs. Device is in production to support existing customers, but TI does not recommend using this part in a new design.

PREVIEW: Device has been announced but is not in production. Samples may or may not be available.

OBSOLETE: TI has discontinued the production of the device.

(2) **RoHS:** TI defines "RoHS" to mean semiconductor products that are compliant with the current EU RoHS requirements for all 10 RoHS substances, including the requirement that RoHS substance do not exceed 0.1% by weight in homogeneous materials. Where designed to be soldered at high temperatures, "RoHS" products are suitable for use in specified lead-free processes. TI may reference these types of products as "Pb-Free".

RoHS Exempt: TI defines "RoHS Exempt" to mean products that contain lead but are compliant with EU RoHS pursuant to a specific EU RoHS exemption.

Green: TI defines "Green" to mean the content of Chlorine (Cl) and Bromine (Br) based flame retardants meet JS709B low halogen requirements of <=1000ppm threshold. Antimony trioxide based flame retardants must also meet the <=1000ppm threshold requirement.

(3) MSL, Peak Temp. - The Moisture Sensitivity Level rating according to the JEDEC industry standard classifications, and peak solder temperature.

(4) There may be additional marking, which relates to the logo, the lot trace code information, or the environmental category on the device.

(5) Multiple Device Markings will be inside parentheses. Only one Device Marking contained in parentheses and separated by a "~" will appear on a device. If a line is indented then it is a continuation of the previous line and the two combined represent the entire Device Marking for that device.

(6) Lead finish/Ball material - Orderable Devices may have multiple material finish options. Finish options are separated by a vertical ruled line. Lead finish/Ball material values may wrap to two lines if the finish value exceeds the maximum column width.

Important Information and Disclaimer:The information provided on this page represents TI's knowledge and belief as of the date that it is provided. TI bases its knowledge and belief on information provided by third parties, and makes no representation or warranty as to the accuracy of such information. Efforts are underway to better integrate information from third parties. TI has taken and continues to take reasonable steps to provide representative and accurate information but may not have conducted destructive testing or chemical analysis on incoming materials and chemicals. TI and TI suppliers consider certain information to be proprietary, and thus CAS numbers and other limited information may not be available for release.

In no event shall TI's liability arising out of such information exceed the total purchase price of the TI part(s) at issue in this document sold by TI to Customer on an annual basis.

TAPE AND REEL INFORMATION

QUADRANT ASSIGNMENTS FOR PIN 1 ORIENTATION IN TAPE

*All dimensions are nominal

| Device | Package Type | Package Drawing | Pins | SPQ | Reel Diameter (mm) | Reel Width W1 (mm) | A0 (mm) | B0 (mm) | K0 (mm) | P1 (mm) | W (mm) | Pin1 Quadrant |
|------------|--------------|-----------------|------|------|--------------------|--------------------|---------|---------|---------|---------|--------|---------------|
| DRV120APWR | TSSOP | PW | 14 | 2000 | 330.0 | 12.4 | 6.9 | 5.6 | 1.6 | 8.0 | 12.0 | Q1 |
| DRV120PWR | TSSOP | PW | 8 | 2000 | 330.0 | 12.4 | 7.0 | 3.6 | 1.6 | 8.0 | 12.0 | Q1 |

TAPE AND REEL BOX DIMENSIONS

*All dimensions are nominal

| Device | Package Type | Package Drawing | Pins | SPQ | Length (mm) | Width (mm) | Height (mm) |
|------------|--------------|-----------------|------|------|-------------|------------|-------------|
| DRV120APWR | TSSOP | PW | 14 | 2000 | 356.0 | 356.0 | 35.0 |
| DRV120PWR | TSSOP | PW | 8 | 2000 | 356.0 | 356.0 | 35.0 |

PW (R-PDSO-G14)

PLASTIC SMALL OUTLINE

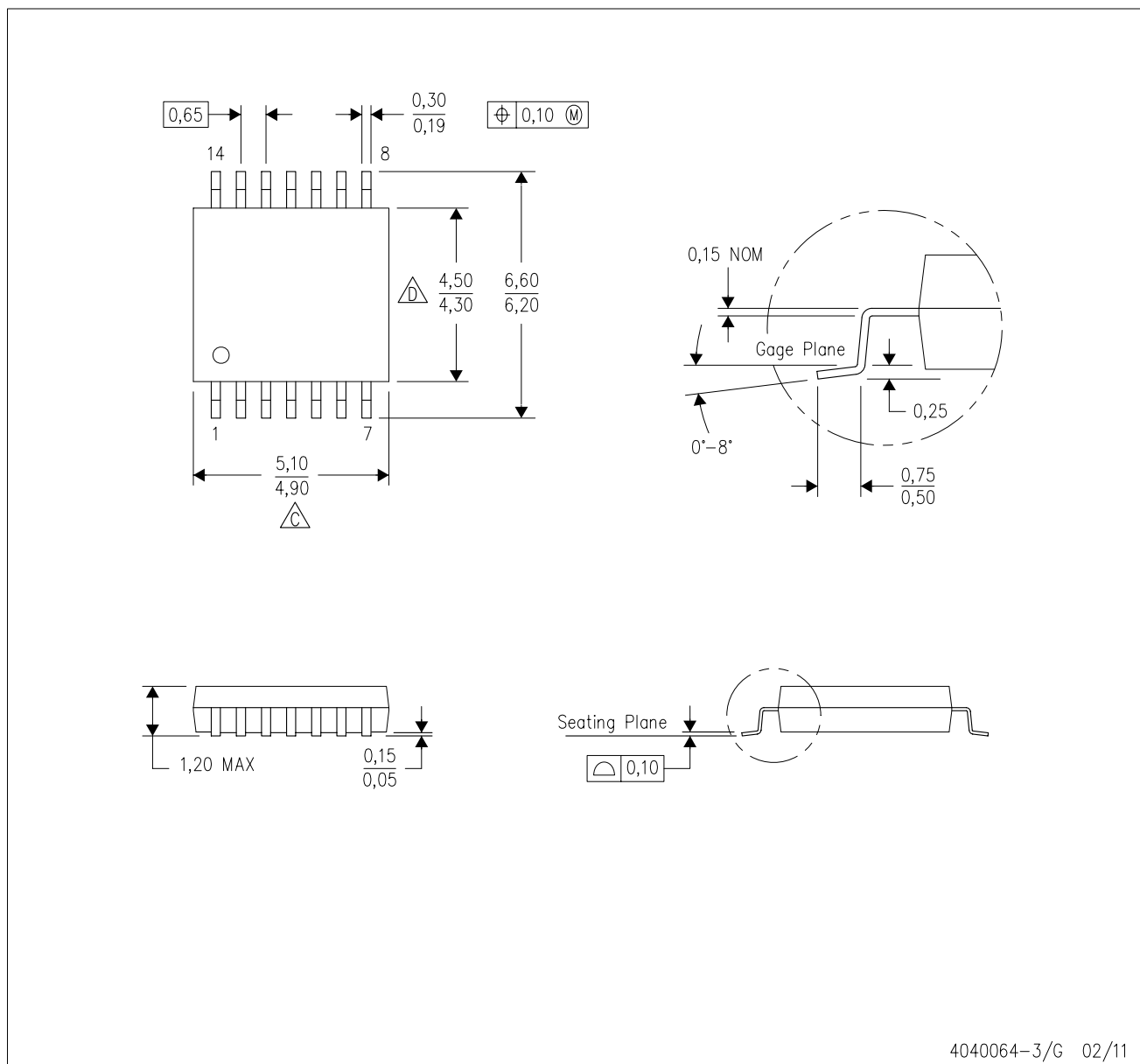

4040064-3/G 02/11

- NOTES:
- A. All linear dimensions are in millimeters. Dimensioning and tolerancing per ASME Y14.5M-1994.
 - B. This drawing is subject to change without notice.
 - C. Body length does not include mold flash, protrusions, or gate burrs. Mold flash, protrusions, or gate burrs shall not exceed 0,15 each side.
 - D. Body width does not include interlead flash. Interlead flash shall not exceed 0,25 each side.
 - E. Falls within JEDEC MO-153

PW (R-PDSO-G14)

PLASTIC SMALL OUTLINE



- NOTES:
- All linear dimensions are in millimeters.
 - This drawing is subject to change without notice.
 - Publication IPC-7351 is recommended for alternate designs.
 - Laser cutting apertures with trapezoidal walls and also rounding corners will offer better paste release. Customers should contact their board assembly site for stencil design recommendations. Refer to IPC-7525 for other stencil recommendations.
 - Customers should contact their board fabrication site for solder mask tolerances between and around signal pads.

PW0008A



PACKAGE OUTLINE

TSSOP - 1.2 mm max height

SMALL OUTLINE PACKAGE



4221848/A 02/2015

NOTES:

1. All linear dimensions are in millimeters. Any dimensions in parenthesis are for reference only. Dimensioning and tolerancing per ASME Y14.5M.
2. This drawing is subject to change without notice.
3. This dimension does not include mold flash, protrusions, or gate burrs. Mold flash, protrusions, or gate burrs shall not exceed 0.15 mm per side.
4. This dimension does not include interlead flash. Interlead flash shall not exceed 0.25 mm per side.
5. Reference JEDEC registration MO-153, variation AA.

EXAMPLE BOARD LAYOUT

PW0008A

TSSOP - 1.2 mm max height

SMALL OUTLINE PACKAGE



LAND PATTERN EXAMPLE
SCALE:10X



SOLDER MASK DETAILS
NOT TO SCALE

4221848/A 02/2015

NOTES: (continued)

- 6. Publication IPC-7351 may have alternate designs.
- 7. Solder mask tolerances between and around signal pads can vary based on board fabrication site.

EXAMPLE STENCIL DESIGN

PW0008A

TSSOP - 1.2 mm max height

SMALL OUTLINE PACKAGE



SOLDER PASTE EXAMPLE
BASED ON 0.125 mm THICK STENCIL
SCALE:10X

4221848/A 02/2015

NOTES: (continued)

8. Laser cutting apertures with trapezoidal walls and rounded corners may offer better paste release. IPC-7525 may have alternate design recommendations.
9. Board assembly site may have different recommendations for stencil design.

重要声明和免责声明

TI“按原样”提供技术和可靠性数据（包括数据表）、设计资源（包括参考设计）、应用或其他设计建议、网络工具、安全信息和其他资源，不保证没有瑕疵且不做任何明示或暗示的担保，包括但不限于对适销性、某特定用途方面的适用性或不侵犯任何第三方知识产权的暗示担保。

这些资源可供使用 TI 产品进行设计的熟练开发人员使用。您将自行承担以下全部责任：(1) 针对您的应用选择合适的 TI 产品，(2) 设计、验证并测试您的应用，(3) 确保您的应用满足相应标准以及任何其他功能安全、信息安全、监管或其他要求。

这些资源如有变更，恕不另行通知。TI 授权您仅可将这些资源用于研发本资源所述的 TI 产品的应用。严禁对这些资源进行其他复制或展示。您无权使用任何其他 TI 知识产权或任何第三方知识产权。您应全额赔偿因在这些资源的使用中对 TI 及其代表造成的任何索赔、损害、成本、损失和债务，TI 对此概不负责。

TI 提供的产品受 [TI 的销售条款](#) 或 [ti.com](#) 上其他适用条款/TI 产品随附的其他适用条款的约束。TI 提供这些资源并不会扩展或以其他方式更改 TI 针对 TI 产品发布的适用的担保或担保免责声明。

TI 反对并拒绝您可能提出的任何其他或不同的条款。

邮寄地址：Texas Instruments, Post Office Box 655303, Dallas, Texas 75265

Copyright © 2022，德州仪器 (TI) 公司