

HD3SS3411-Q1 单通道差分 2:1 复用器/解复用器

1 特性

- 符合汽车级 Q100 标准
- 兼容多种接口标准，包括 FPD-Link、LVDS、PCIE 第 II 代和第 III 代、XAUI 以及 USB3.1
- 运行速率高达 10Gbps
- 3dB 差分带宽宽达 7.5GHz 左右
- 出色动态特性（4GHz 时）
 - 插入损耗 = -1.1dB
 - 回波损耗 = -11.3dB
 - 断开隔离 = -19dB
- 双向“复用/解复用”差分开关
- 支持 0V 到 2V 共模电压
- 单电源电压 V_{CC} : 3.3V±10%
- 40°C 至 105°C 的工业温度范围

2 应用

- 车用信息娱乐
- 工业数据交换
- 台式机和笔记本个人电脑 (PC)
- 服务器/储存区网络
- PCI EXPRESS 背板
- 共享 I/O 端口

4 简化电路原理图

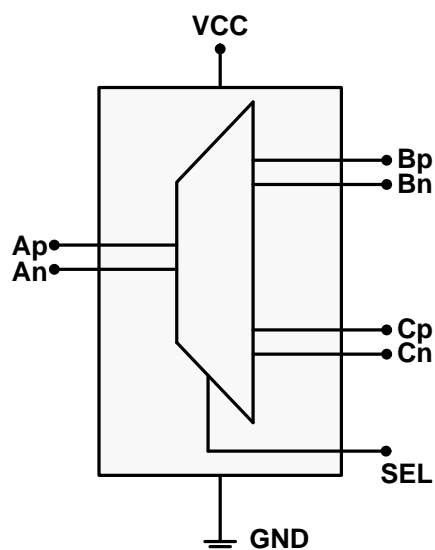

3 说明

HD3SS3411-Q1 是一款高速双向无源开关，可采用复用器或解复用器两种配置。该器件可通过控制引脚 SEL 在两个差分通道（端口 B 到端口 A，或者端口 C 到端口 A）间切换。

HD3SS3411-Q1 是一款通用模拟差动无源开关，只要在 0V 至 2V 的共模电压范围内偏置，并且具有差分幅值高达 1800mVpp 的差分信号，即可用于任何高速接口应用。该器件采用自适应跟踪，可确保信道在整个共模电压范围内保持不变。

该器件具有出色的动态特性，可在信号眼图衰减最小的情况下实现高速转换，并且附加抖动极少。该器件在工作模式下的功耗 < 2mW；在关断模式下的功耗 < 2μW（可通过 OEn 引脚切换模式）。

器件信息⁽¹⁾

器件型号	封装	封装尺寸 (标称值)
HD3SS3411-Q1	WQFN (14)	3.50mm x 3.50mm
HD3SS3411I		
HD3SS3411		

(1) 要了解所有可用封装，请见数据表末尾的可订购产品附录。



目录

1	特性	1	9	Application Information and Implementation	9
2	应用	1	9.1	Application Information.....	9
3	说明	1	9.2	Typical Application	9
4	简化电路原理图	1	9.3	Design Requirements.....	10
5	修订历史记录	2	9.4	Detailed Design Procedure	10
6	Pin Configuration and Functions	3	9.5	Application Curves	12
7	Specifications	4	10	Power Supply Recommendations	12
7.1	Absolute Maximum Ratings	4	11	Layout	13
7.2	ESD Ratings.....	4	11.1	Layout Guidelines	13
7.3	Recommended Operating Conditions.....	4	11.2	Layout Example	14
7.4	Thermal Information	4	12	器件和文档支持	15
7.5	Electrical Characteristics.....	5	12.1	文档支持	15
7.6	Timing Requirements	5	12.2	社区资源	15
7.7	Typical Characteristics	6	12.3	商标	15
8	Detailed Description	7	12.4	静电放电警告	15
8.1	Overview	7	12.5	出口管制提示	15
8.2	Functional Block Diagram	7	12.6	Glossary	15
8.3	Feature Description.....	7	13	机械、封装和可订购信息	15
8.4	Device Functional Modes.....	8			

5 修订历史记录

Changes from Original (June 2015) to Revision A

Page

•	Changed the "Operating free-air Temperature" MAX value From: 85°C To: 105°C in <i>Recommended Operating Conditions</i>	4
•	Changed the MAX value of $R_{(FLAT_ON)}$ From: 0.5 Ω To: 1 Ω in the <i>Electrical Characteristics</i>	5

6 Pin Configuration and Functions

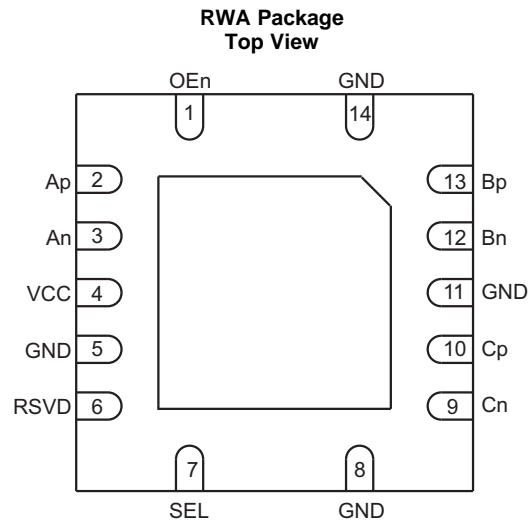

Pin Functions

NAME	NO	TYPE	DESCRIPTION
Ap	2	I/O	Port A, High Speed Positive Signal
An	3	I/O	Port A, High Speed Negative Signal
Bp	13	I/O	Port B, High Speed Positive Signal
Bn	12	I/O	Port B, High Speed Negative Signal
Cp	10	I/O	Port C, High Speed Positive Signal
Cn	9	I/O	Port C, High Speed Negative Signal
GND	5,8,11,14, Pad	G	Ground
OEn	1	I	Active Low Chip Enable L: Normal operation H: Shutdown
RSVD	6	I/O	Reserved Pin – connect or pull-down to GND
SEL	7	I	Port select pin L: Port A to Port B H: Port A to Port C
VCC	4	P	3.3 V power

7 Specifications

7.1 Absolute Maximum Ratings⁽¹⁾

Over operating free-air temperature range (unless otherwise noted)

		MIN	MAX	UNIT
Supply voltage range (V_{CC})	Absolute minimum/maximum supply voltage range	-0.5	4	V
Voltage range	Differential I/O	-0.5	2.5	V
	Control pin	-0.5	$V_{DD} + 0.5$	

- (1) Stresses beyond those listed under *absolute maximum ratings* may cause permanent damage to the device. These are stress ratings only and functional operation of the device at these or any conditions beyond those indicated under *recommended operating conditions* is not implied. Exposure to absolute-maximum-rated conditions for extended periods may affect device reliability.

7.2 ESD Ratings

		VALUE	UNIT
$V_{(ESD)}$ Electrostatic discharge	Human-body model (HBM), per AEC Q100-002 ⁽¹⁾	± 2000	V
	Charged-device model (CDM), per AEC Q100-011	± 500	

- (1) AEC Q100-002 indicates that HBM stressing shall be in accordance with the ANSI/ESDA/JEDEC JS-001 specification.

7.3 Recommended Operating Conditions

over operating free-air temperature range (unless otherwise noted)

		MIN	NOM	MAX	UNIT
V_{CC}	Supply voltage	3		3.6	V
V_{IH}	Input high voltage (SEL, OEn Pin)	2		V_{CC}	V
V_{IL}	Input low voltage (SEL OEn Pin)	-0.1		0.8	V
V_{Diff}	High speed signal pins differential voltage	0		1.8	V_{PP}
V_{CM}	Common mode voltage (differential pins)	0		2	V
T_A	Operating free-air temperature	-40		105	°C

7.4 Thermal Information

THERMAL METRIC ⁽¹⁾		RWA	UNIT
		14 PINS	
$R_{\theta JA}$	Junction-to-ambient thermal resistance	50.5	°C/W
$R_{\theta JC(top)}$	Junction-to-case (top) thermal resistance	63.1	
$R_{\theta JB}$	Junction-to-board thermal resistance	26.4	
Ψ_{JT}	Junction-to-top characterization parameter	2.2	
Ψ_{JB}	Junction-to-board characterization parameter	26.5	
$R_{\theta JC(bot)}$	Junction-to-case (bottom) thermal resistance	7.3	

- (1) For more information about traditional and new thermal metrics, see the *IC Package Thermal Metrics* application report, [SPRA953](#).

7.5 Electrical Characteristics

over operating free-air temperature range (unless otherwise noted)

PARAMETER		TEST CONDITIONS	MIN	TYP	MAX	UNITS
I_{CC}	Device active Current	$V_{CC} = 3.3\text{ V}$, $OEn = 0$		0.6	0.8	mA
I_{STDN}	Device shutdown Current	$V_{CC} = 3.3\text{ V}$, $OEn = 0$		0.3	0.6	μA
C_{ON}	Outputs ON Capacitance			0.6		pF
R_{ON}	Output ON resistance	$V_{CC} = 3.3\text{ V}$; $V_{CM} = 0\text{ V to } 2\text{ V}$; $I_O = -8\text{ mA}$		5	8	Ω
ΔR_{ON}	On resistance match between pairs of the same channel	$V_{CC} = 3.3\text{ V}$; $-0.35\text{ V} \leq V_{IN} \leq 2.35\text{ V}$; $I_O = -8\text{ mA}$			0.5	Ω
$R_{(FLAT_ON)}$	On resistance flatness ($R_{ON(MAX)} - R_{ON(MAIN)}$)	$V_{DD} = 3.3\text{ V}$; $-0.35\text{ V} \leq V_{IN} \leq 2.35\text{ V}$			1	Ω
$I_{IH(CTRL)}$	Input high current, control pins (SEL, OEn)				1	μA
$I_{IL(CTRL)}$	Input low current, control pins (SEL, OEn)				1	μA
$I_{IH(HS)}$	Input high current, high speed pins	[A/B/C][p/n] $V_{IN} = 2\text{ V}$ for selected port, A and B with SEL= 0, and A and C with SEL = V_{CC}			1	μA
		[A/B/C][p/n] $V_{IN} = 2\text{ V}$ for non-selected port, C with SEL= 0, and B with SEL = V_{CC} (Note there is a 20 K Ω pull-down in non-selected port)		100	140	μA
$I_{IL(HS)}$	Input low current, high speed pins	[A/B/C][p/n]			1	μA
High Speed Performance						
I_L	Differential Insertion Loss	$f = 0.3\text{ MHz}$		-0.5		dB
		$f = 2.5\text{ GHz}$		-0.7		
		$f = 4\text{ GHz}$		-1.1		
BW	-3 dB Bandwidth			7.5		GHz
R_L	Differential return loss	$f = 0.3\text{ MHz}$		-26.4		dB
		$f = 2.5\text{ GHz}$		-16.6		
		$f = 4\text{ GHz}$		-11.3		
O_I	Differential OFF isolation	$f = 0.3\text{ MHz}$		-75		dB
		$f = 2.5\text{ GHz}$		-22		
		$f = 4\text{ GHz}$		-19		
Xtalk	Differential Crosstalk	$f = 4\text{ GHz}$		-35		dB

7.6 Timing Requirements

		MIN	NOM	MAX	UNIT
t_{PD}	Switch propagation delay			80	ps
t_{SW}	Switching time			0.5	ns
t_{SK_INTRA}	Intra-pair output skew			5	ps

7.7 Typical Characteristics

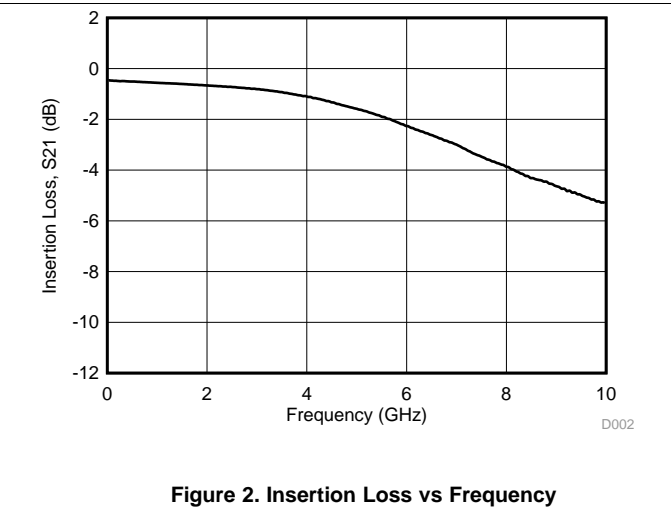
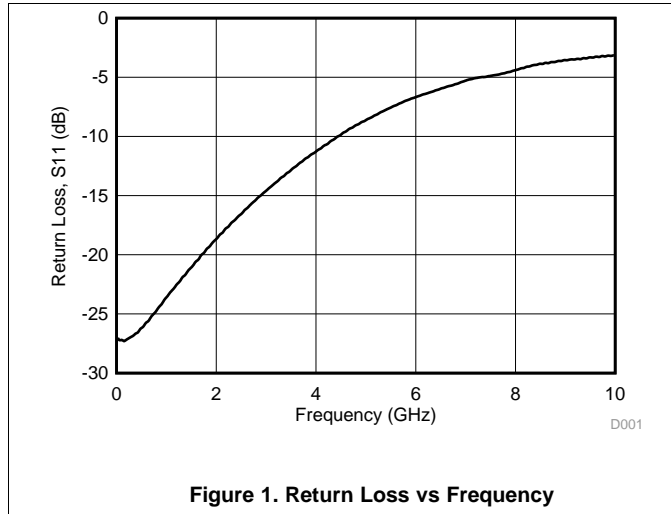

8 Detailed Description

8.1 Overview

The HD3SS3411-Q1 is a high-speed bi-directional passive switch in mux or demux configurations. Based on control pin SEL, the device switches one differential channels between Port B or Port C to Port A.

The HD3SS3411-Q1 is a generic analog differential passive switch that can work for any high speed interface applications as long as it is biased at a common mode voltage range of 0 V to 2 V and has differential signaling with differential amplitude up to 1800 mVpp. The device employs an adaptive tracking that ensures the channel remains unchanged for entire common mode voltage range.

Table 1. MUX Pin Connections⁽¹⁾

PORT A CHANNEL	PORT B OR PORT C CHANNEL CONNECTED TO PORT A CHANNEL	
	SEL = L	SEL = H
Ap	Bp	Cp
An	Bn	Cn

(1) The HD3SS3411-Q1 can tolerate polarity inversions for all differential signals on Ports A, B and C. Care should be taken to ensure the same polarity is maintained on Port A vs. Port B/C.

8.2 Functional Block Diagram

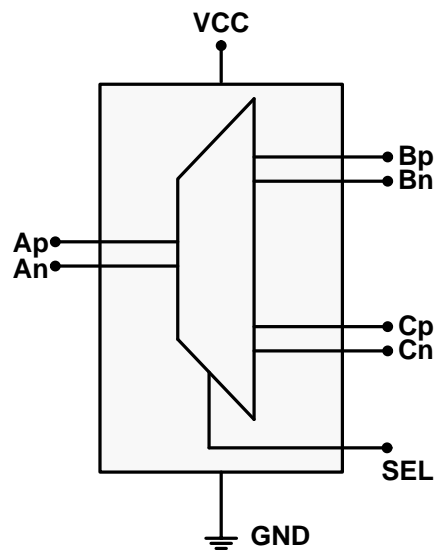

8.3 Feature Description

8.3.1 Output Enable and Power Savings

The HD3SS3411-Q1 has two power modes, normal operating mode and shutdown mode. During shutdown mode, the device consumes very-little current to save the maximum power. The OEn control pin is used to toggle between the two modes.

HD3SS3411-Q1 consumes < 2 mW of power when operational and has a shutdown mode exercisable by the OEn pin resulting < 20 μ W.

8.4 Device Functional Modes

The OEn control pin selects the functional mode of HD3SS3411-Q1. To enter standby/shutdown mode, the OEn control pin is pulled high through a resistor and must remain high. For active/normal operation, the OEn control pin should be pulled low to GND or dynamically controlled to switch between H or L.

Table 2. Device Power Modes

OEn	Device State	Signal Pins
L	Normal	Normal
H	Shutdown	Tri-stated

9 Application Information and Implementation

NOTE

Information in the following applications sections is not part of the TI component specification, and TI does not warrant its accuracy or completeness. TI's customers are responsible for determining suitability of components for their purposes. Customers should validate and test their design implementation to confirm system functionality.

9.1 Application Information

HD3SS3411-Q1 mux channels have independent adaptive common mode tracking allowing RX and TX paths to have different common mode voltage simplifying system implementation and avoiding inter-operational issues.

HD3SS3411-Q1 mux does not provide common mode biasing for the channel. Therefore, it is required that the device is biased from either side for all active channels.

The HD3SS3411 supports several high-speed data protocols with a differential amplitude of < 1800 mVpp and a common mode voltage of < 2 V, as with USB 3.1 and DisplayPort 1.3. The one select input (SEL) pin can be controlled by an available GPIO pin within a system or from a microcontroller.

9.2 Typical Application

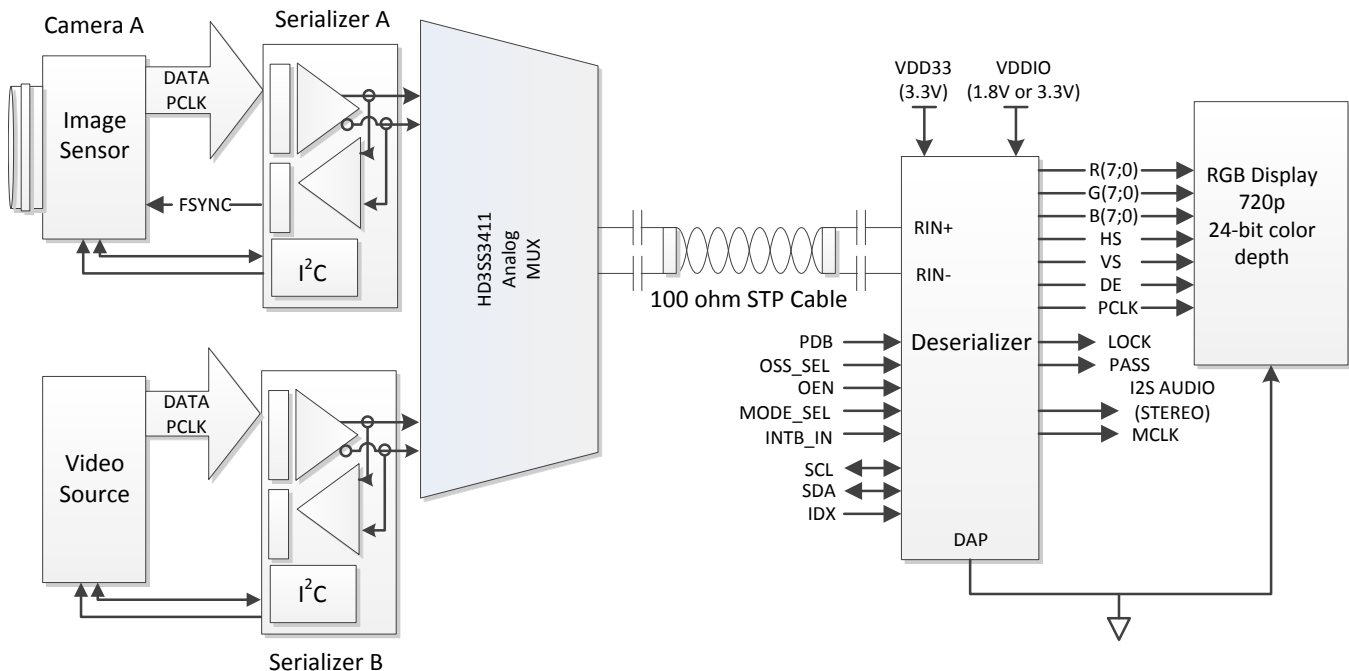

Figure 3. FPD Link III Application

9.3 Design Requirements

For this design example, use the values shown in [Table 3](#).

Table 3. Design Parameters

PARAMETER	VALUE
V_{CC} voltage	3.3 V
Ap/n, Bp/n, Cp/n CM input voltage	0 V to 2 V
SEL/OEn pin max voltage for low	0 V
SEL/OEn pin min voltage for high	3.3 V

9.4 Detailed Design Procedure

9.4.1 AC Coupling Capacitors

Many interfaces require AC coupling between the transmitter and receiver. The 0402 capacitors are the preferred option to provide AC coupling, and the 0603 size capacitors will also work. The 0805 size capacitors and C-packs should be avoided. When placing AC coupling capacitors symmetric placement is best. A capacitor value of 0.1 μF is best and the value should be match for the \pm signal pair. The placement should be along the TX pairs on the system board, which are usually routed on the top layer of the board.

There are several placement options for the AC coupling capacitors. Because the switch requires a bias voltage, the capacitors must only be placed on one side of the switch. If they are placed on both sides of the switch, a biasing voltage should be provided. A few placement options are shown below. In [Figure 4](#), the coupling capacitors are placed between the switch and endpoint. In this situation, the switch is biased by the system/host controller.

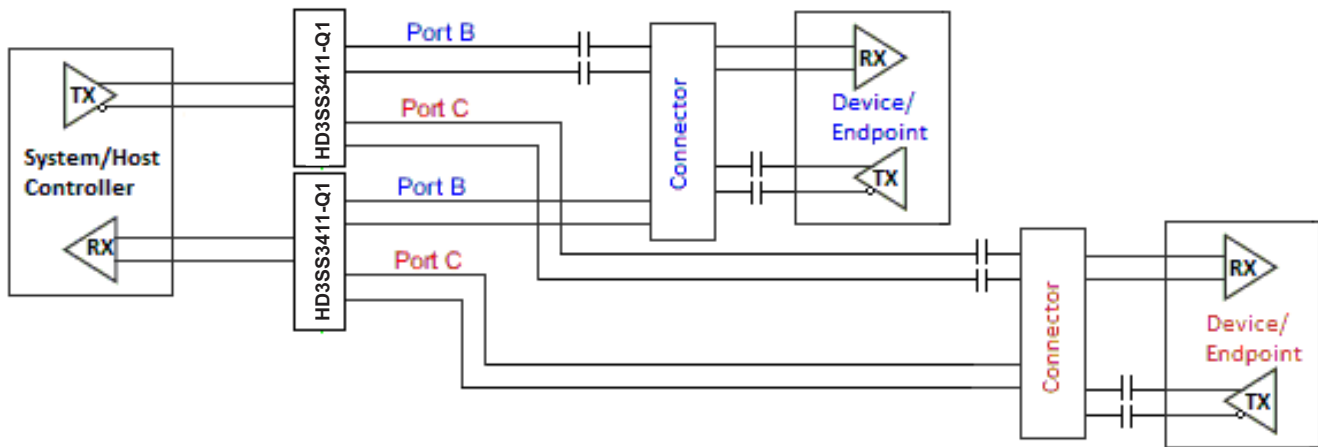

Figure 4. AC Coupling Capacitors Between Switch TX and Endpoint TX

Detailed Design Procedure (continued)

In Figure 5, the coupling capacitors are placed on the host transmit pair and endpoint transmit pair. In this situation, the switch on the top is biased by the endpoint and the lower switch is biased by the host controller.

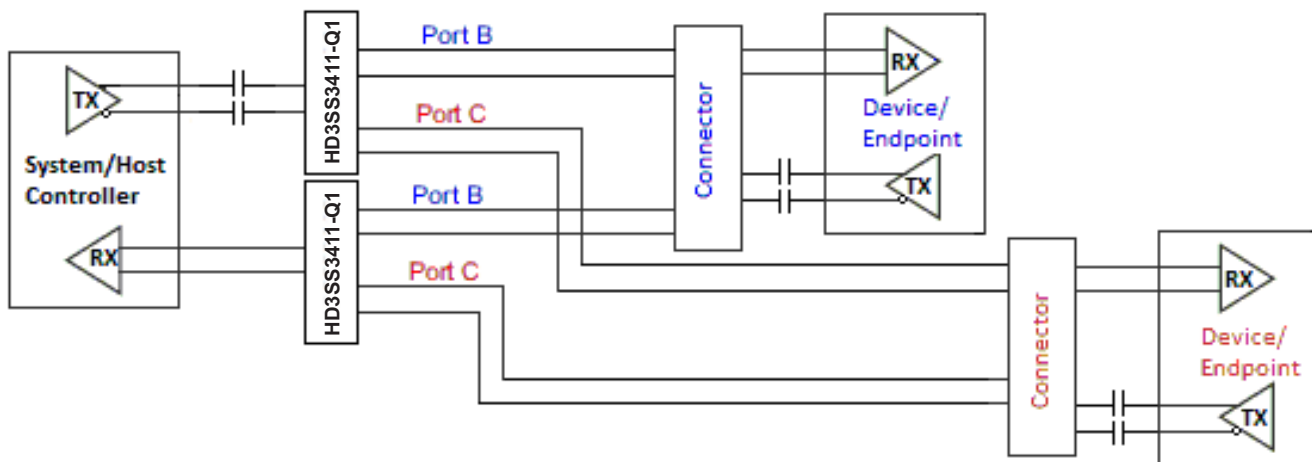

Figure 5. AC Coupling Capacitors on Host TX and Endpoint TX

If the common mode voltage in the system is higher than 2 V, the coupling capacitors are placed on both sides of the switch (shown in Figure 6). A biasing voltage of less than 2 V is required in this case.

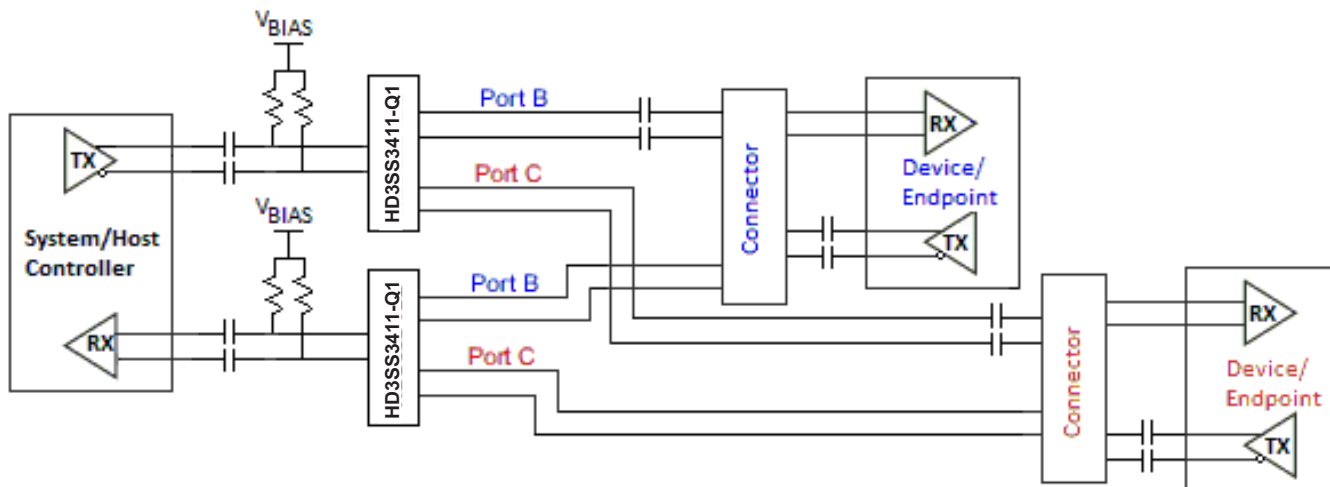

Figure 6. AC Coupling Capacitors on Both Sides of Switch

9.5 Application Curves

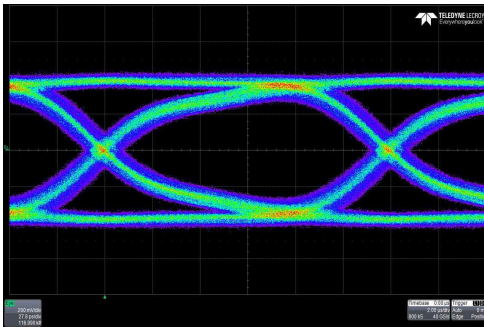

Figure 7. 6 Gbps Source Eye Diagram

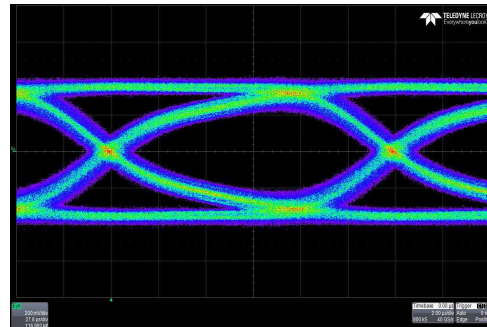

Figure 8. 6 Gbps Output Eye Diagram

10 Power Supply Recommendations

There is no power supply sequence required for HD3SS3411-Q1. However, it is recommended that OEn is asserted low after device supply V_{CC} is stable and in specifications. It is also recommended that ample decoupling capacitors are placed at the device V_{CC} near the pin.

11 Layout

11.1 Layout Guidelines

11.1.1 Critical Routes

- The high speed differential signals must be routed with great care to minimize signal quality degradation between the connector and the source or sink of the high speed signals by following the guidelines provided in this document. Depending on the configuration schemes, the speed of each differential pair can reach a maximum speed of 10 Gbps. These signals are to be routed first before other signals with highest priority.
- Each differential pair should be routed together with controlled differential impedance of 85- Ω to 90- Ω and 50- Ω common mode impedance. Keep away from other high speed signals. The number of vias should be kept to minimum. Each pair should be separated from adjacent pairs by at least 3 times the signal trace width. Route all differential pairs on the same group of layers (Outer layers or inner layers) if not on the same layer. No 90 degree turns on any of the differential pairs. If bends are used on high speed differential pairs, the angle of the bend should be greater than 135 degrees.
- Length matching:
 - Keep high speed differential pairs lengths within 5 mil of each other to keep the intra-pair skew minimum. The inter-pair matching of the differential pairs is not as critical as intra-pair matching.
- Keep high speed differential pair traces adjacent to ground plane.
- Do not route differential pairs over any plane split.
- ESD components on the high speed differential lanes should be placed nearest to the connector in a pass through manner without stubs on the differential path.
- For ease of routing, the P and N connection of the USB3.1 differential pairs to the HD3SS3411-Q1 pins can be swapped.

11.1.2 General Routing/Placement Rules

- Follow 20H rule (H is the distance to ref-plane) for separation of the high speed trace from the edge of the plane.
- Minimize parallelism of high speed clocks and other periodic signal traces to high speed lines.
- All differential pairs should be routed on the top or bottom layer (microstrip traces) if possible or on the same group of layers. Vias should only be used in the breakout region of the device to route from the top to bottom layer when necessary. Avoid using vias in the main region of the board at all cost. Use a ground reference via next to signal via. Distance between ground reference via and signal need to be calculated to have similar impedance as traces.
- All differential signals should not be routed over plane split. Changing signal layers is preferable to crossing plane splits.
- Use of and proper placement of stitching caps when split plane crossing is unavoidable to account for high frequency return current path.
- Route differential traces over a continuous plane with no interruptions.
- Do not route differential traces under power connectors or other interface connectors, crystals, oscillators, or any magnetic source.
- Route traces away from etching areas like pads, vias, and other signal traces. Try to maintain a 20 mil keep out distance where possible.
- Decoupling caps should be placed next to each power terminal on the HD3SS3411-Q1. Care should be taken to minimize the stub length of the trace connecting the capacitor to the power pin.
- Avoid sharing vias between multiple decoupling caps.
- Place vias as close as possible to the decoupling cap solder pad.
- Widen VCC/GND planes to reduce effect of static and dynamic IR drop.

11.2 Layout Example

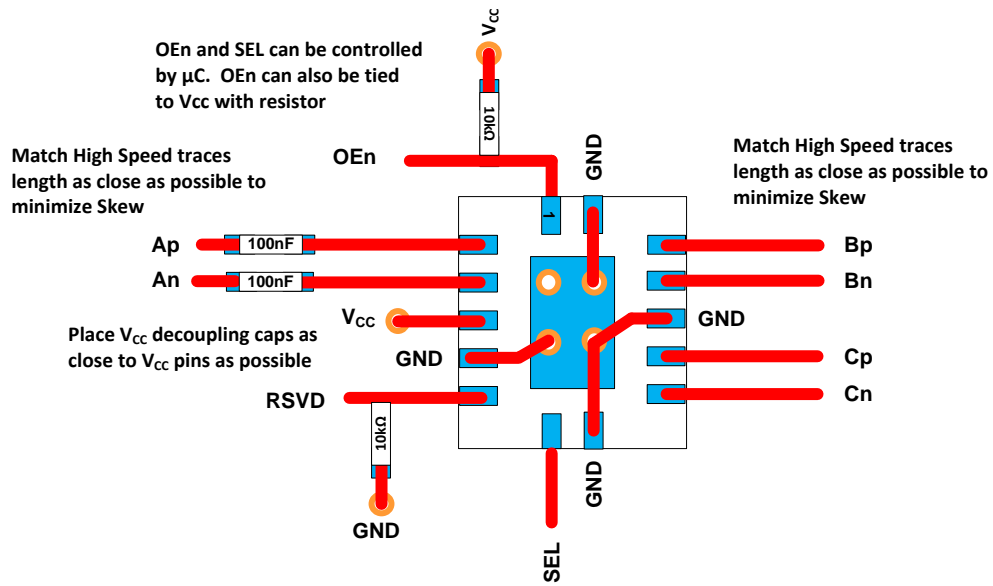

Figure 9. Layout

12 器件和文档支持

12.1 文档支持

12.2 社区资源

The following links connect to TI community resources. Linked contents are provided "AS IS" by the respective contributors. They do not constitute TI specifications and do not necessarily reflect TI's views; see TI's [Terms of Use](#).

TI E2E™ Online Community *TI's Engineer-to-Engineer (E2E) Community*. Created to foster collaboration among engineers. At e2e.ti.com, you can ask questions, share knowledge, explore ideas and help solve problems with fellow engineers.

Design Support *TI's Design Support* Quickly find helpful E2E forums along with design support tools and contact information for technical support.

12.3 商标

E2E is a trademark of Texas Instruments.

All other trademarks are the property of their respective owners.

12.4 静电放电警告



这些装置包含有限的内置 ESD 保护。存储或装卸时，应将导线一起截短或将装置放置于导电泡棉中，以防止 MOS 门极遭受静电损伤。

12.5 出口管制提示

接收方同意：如果美国或其他适用法律限制或禁止将通过非披露义务的披露方获得的任何产品或技术数据（其中包括软件）（见美国、欧盟和其他出口管理条例之定义）、或者其他适用国家条例限制的任何受管制产品或此项技术的任何直接产品出口或再出口至任何目的地，那么在没有事先获得美国商务部和其他相关政府机构授权的情况下，接收方不得在知情的情况下，以直接或间接的方式将其出口。

12.6 Glossary

SLYZ022 — *TI Glossary*.

This glossary lists and explains terms, acronyms, and definitions.

13 机械、封装和可订购信息

以下页中包括机械、封装和可订购信息。 这些信息是针对指定器件可提供的最新数据。 这些数据会在无通知且不对本文档进行修订的情况下发生改变。 欲获得该数据表的浏览器版本，请查阅左侧的导航栏。

PACKAGING INFORMATION

Orderable Device	Status (1)	Package Type	Package Drawing	Pins	Package Qty	Eco Plan (2)	Lead finish/ Ball material (6)	MSL Peak Temp (3)	Op Temp (°C)	Device Marking (4/5)	Samples
HD3SS3411RWARQ1	PREVIEW	WQFN	RWA	14	3000	TBD	Call TI	Call TI	-40 to 105		
HD3SS3411TRWARQ1	ACTIVE	WQFN	RWA	14	3000	RoHS & Green	NIPDAU	Level-2-260C-1 YEAR	-40 to 105	3411Q	Samples

(1) The marketing status values are defined as follows:

ACTIVE: Product device recommended for new designs.

LIFEBUY: TI has announced that the device will be discontinued, and a lifetime-buy period is in effect.

NRND: Not recommended for new designs. Device is in production to support existing customers, but TI does not recommend using this part in a new design.

PREVIEW: Device has been announced but is not in production. Samples may or may not be available.

OBSELETE: TI has discontinued the production of the device.

(2) **RoHS:** TI defines "RoHS" to mean semiconductor products that are compliant with the current EU RoHS requirements for all 10 RoHS substances, including the requirement that RoHS substance do not exceed 0.1% by weight in homogeneous materials. Where designed to be soldered at high temperatures, "RoHS" products are suitable for use in specified lead-free processes. TI may reference these types of products as "Pb-Free".

RoHS Exempt: TI defines "RoHS Exempt" to mean products that contain lead but are compliant with EU RoHS pursuant to a specific EU RoHS exemption.

Green: TI defines "Green" to mean the content of Chlorine (Cl) and Bromine (Br) based flame retardants meet JS709B low halogen requirements of <=1000ppm threshold. Antimony trioxide based flame retardants must also meet the <=1000ppm threshold requirement.

(3) MSL, Peak Temp. - The Moisture Sensitivity Level rating according to the JEDEC industry standard classifications, and peak solder temperature.

(4) There may be additional marking, which relates to the logo, the lot trace code information, or the environmental category on the device.

(5) Multiple Device Markings will be inside parentheses. Only one Device Marking contained in parentheses and separated by a "~" will appear on a device. If a line is indented then it is a continuation of the previous line and the two combined represent the entire Device Marking for that device.

(6) Lead finish/Ball material - Orderable Devices may have multiple material finish options. Finish options are separated by a vertical ruled line. Lead finish/Ball material values may wrap to two lines if the finish value exceeds the maximum column width.

Important Information and Disclaimer:The information provided on this page represents TI's knowledge and belief as of the date that it is provided. TI bases its knowledge and belief on information provided by third parties, and makes no representation or warranty as to the accuracy of such information. Efforts are underway to better integrate information from third parties. TI has taken and continues to take reasonable steps to provide representative and accurate information but may not have conducted destructive testing or chemical analysis on incoming materials and chemicals. TI and TI suppliers consider certain information to be proprietary, and thus CAS numbers and other limited information may not be available for release.

In no event shall TI's liability arising out of such information exceed the total purchase price of the TI part(s) at issue in this document sold by TI to Customer on an annual basis.

OTHER QUALIFIED VERSIONS OF HD3SS3411-Q1 :

- Catalog : [HD3SS3411](#)

NOTE: Qualified Version Definitions:

- Catalog - TI's standard catalog product

TAPE AND REEL INFORMATION

QUADRANT ASSIGNMENTS FOR PIN 1 ORIENTATION IN TAPE



*All dimensions are nominal

Device	Package Type	Package Drawing	Pins	SPQ	Reel Diameter (mm)	Reel Width W1 (mm)	A0 (mm)	B0 (mm)	K0 (mm)	P1 (mm)	W (mm)	Pin1 Quadrant
HD3SS3411TRWARQ1	WQFN	RWA	14	3000	330.0	12.4	3.75	3.75	1.15	8.0	12.0	Q2

TAPE AND REEL BOX DIMENSIONS

*All dimensions are nominal

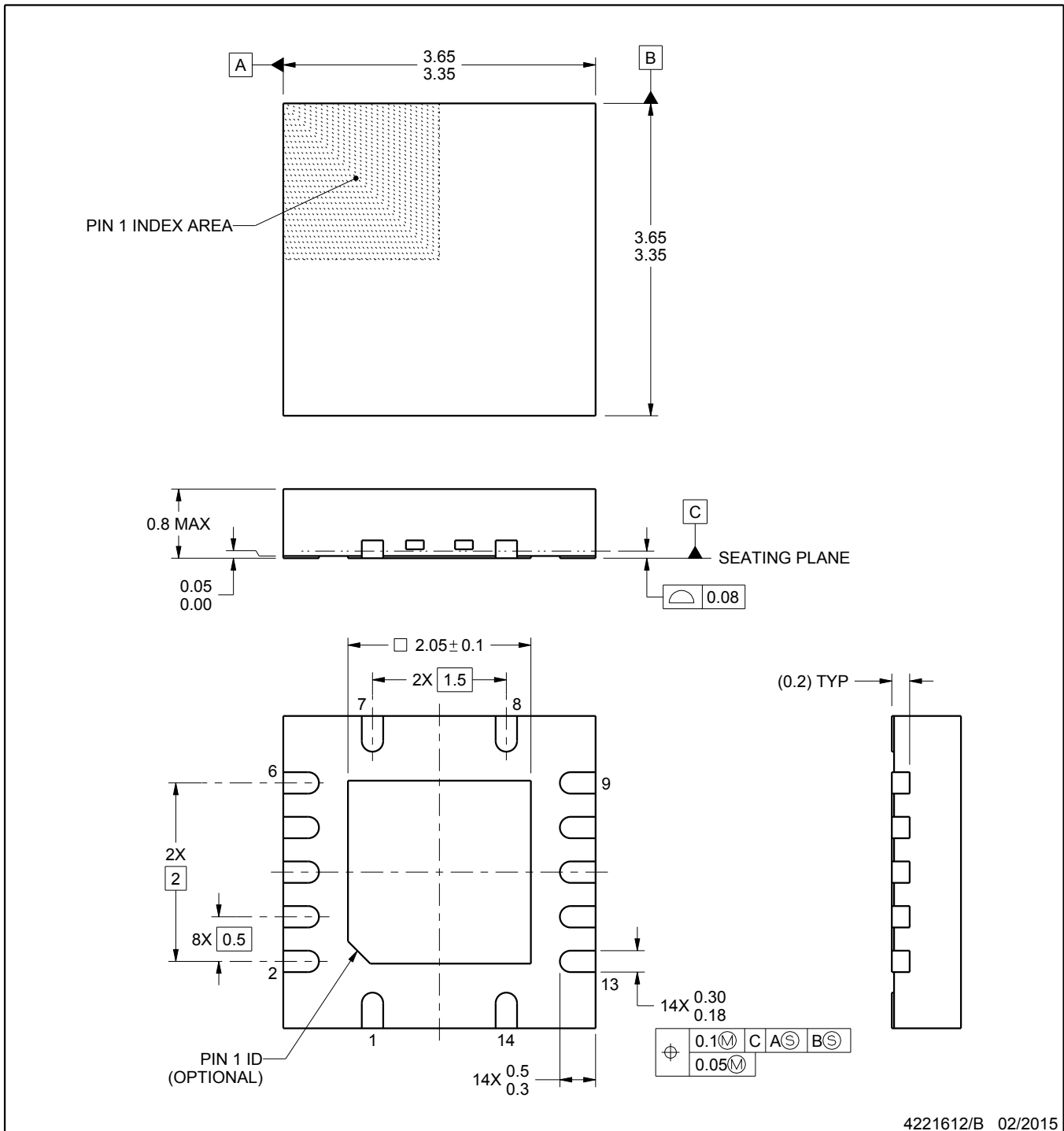
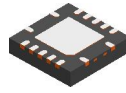
Device	Package Type	Package Drawing	Pins	SPQ	Length (mm)	Width (mm)	Height (mm)
HD3SS3411TRWARQ1	WQFN	RWA	14	3000	346.0	346.0	33.0



4221612/B 02/2015

NOTES:

1. All linear dimensions are in millimeters. Any dimensions in parenthesis are for reference only. Dimensioning and tolerancing per ASME Y14.5M.
2. This drawing is subject to change without notice.
3. The package thermal pad must be soldered to the printed circuit board for thermal and mechanical performance.

EXAMPLE BOARD LAYOUT

RWA0014A

WQFN - 0.8 mm max height

PLASTIC QUAD FLATPACK - NO LEAD

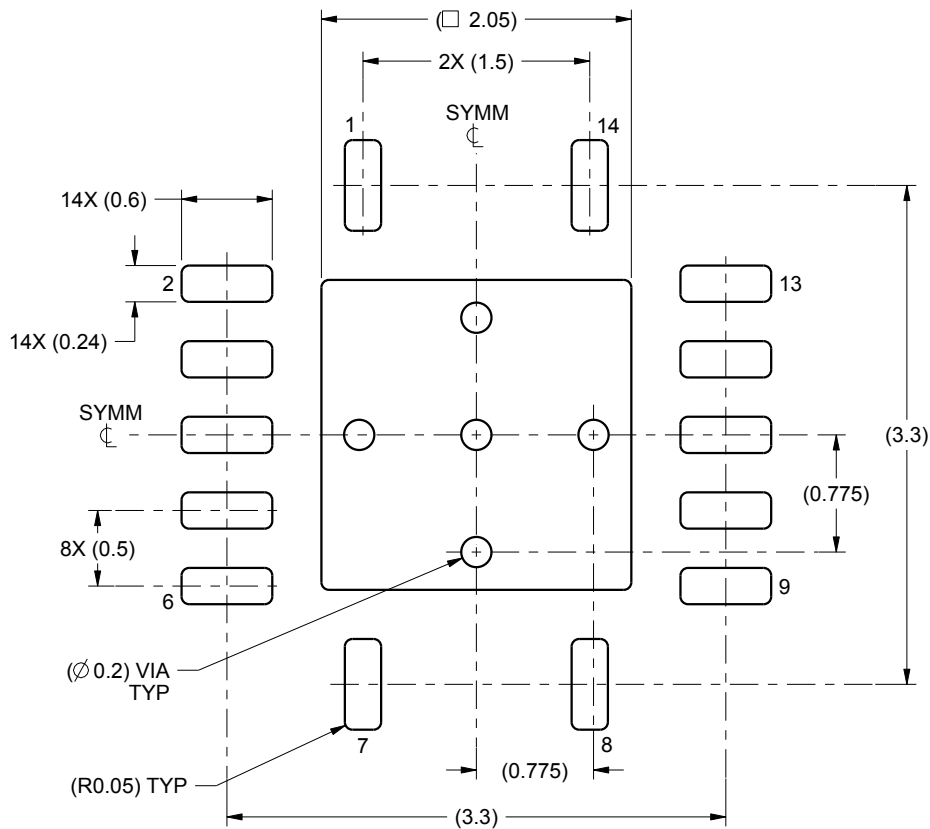

LAND PATTERN EXAMPLE
SCALE:20X

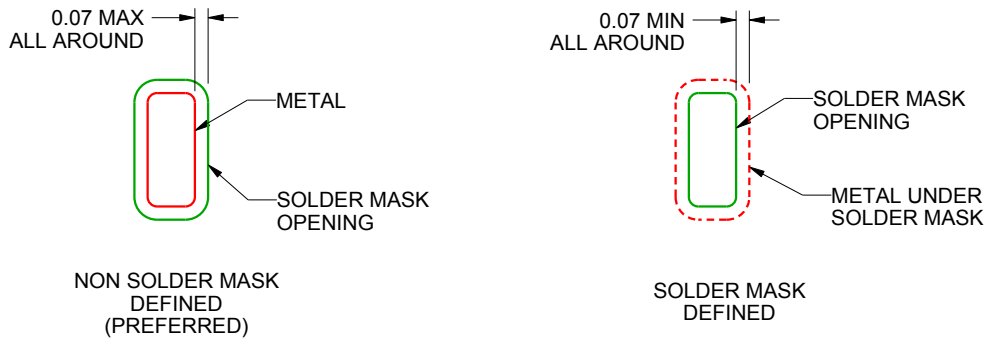

SOLDER MASK DETAILS

4221612/B 02/2015

NOTES: (continued)

4. This package is designed to be soldered to a thermal pad on the board. For more information, see Texas Instruments literature number SLUA271 (www.ti.com/lit/slua271).

EXAMPLE STENCIL DESIGN

RWA0014A

WQFN - 0.8 mm max height

PLASTIC QUAD FLATPACK - NO LEAD

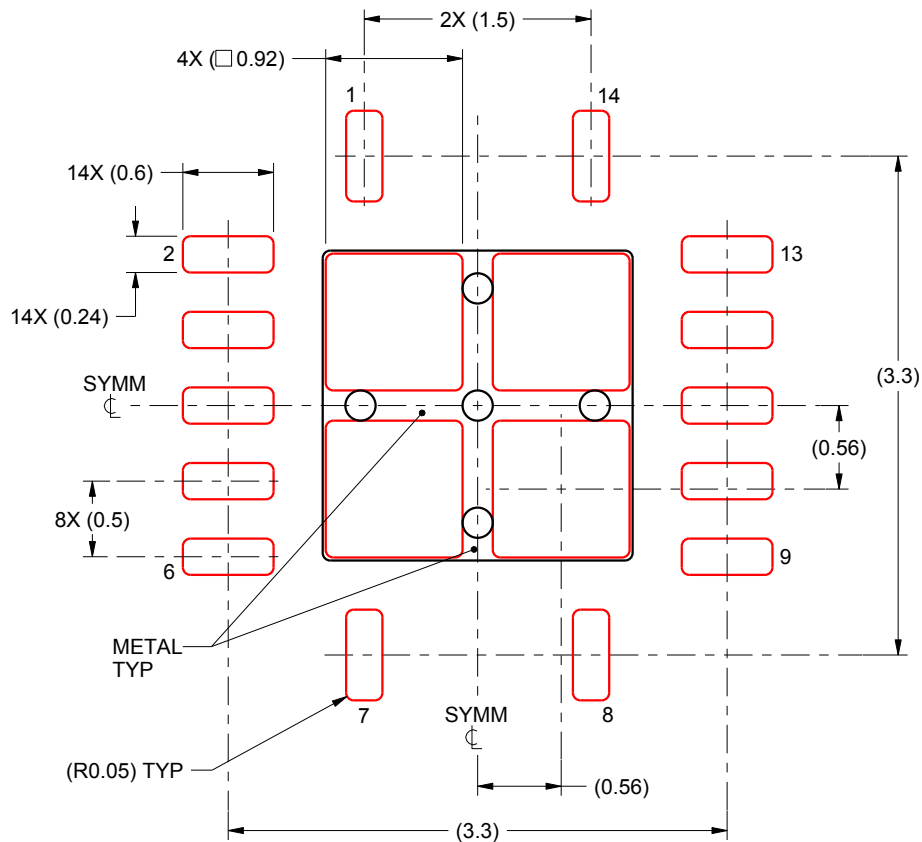

SOLDER PASTE EXAMPLE
BASED ON 0.125 mm THICK STENCIL

EXPOSED PAD
80% PRINTED SOLDER COVERAGE BY AREA
SCALE:20X

4221612/B 02/2015

NOTES: (continued)

5. Laser cutting apertures with trapezoidal walls and rounded corners may offer better paste release. IPC-7525 may have alternate design recommendations.

重要声明和免责声明

TI“按原样”提供技术和可靠性数据（包括数据表）、设计资源（包括参考设计）、应用或其他设计建议、网络工具、安全信息和其他资源，不保证没有瑕疵且不做任何明示或暗示的担保，包括但不限于对适销性、某特定用途方面的适用性或不侵犯任何第三方知识产权的暗示担保。

这些资源可供使用 TI 产品进行设计的熟练开发人员使用。您将自行承担以下全部责任：(1) 针对您的应用选择合适的 TI 产品，(2) 设计、验证并测试您的应用，(3) 确保您的应用满足相应标准以及任何其他功能安全、信息安全、监管或其他要求。

这些资源如有变更，恕不另行通知。TI 授权您仅可将这些资源用于研发本资源所述的 TI 产品的应用。严禁对这些资源进行其他复制或展示。您无权使用任何其他 TI 知识产权或任何第三方知识产权。您应全额赔偿因在这些资源的使用中对 TI 及其代表造成的任何索赔、损害、成本、损失和债务，TI 对此概不负责。

TI 提供的产品受 [TI 的销售条款](#) 或 [ti.com](#) 上其他适用条款/TI 产品随附的其他适用条款的约束。TI 提供这些资源并不会扩展或以其他方式更改 TI 针对 TI 产品发布的适用的担保或担保免责声明。

TI 反对并拒绝您可能提出的任何其他或不同的条款。

邮寄地址：Texas Instruments, Post Office Box 655303, Dallas, Texas 75265

Copyright © 2023，德州仪器 (TI) 公司