

OPA1671 13MHz、低噪声、轨至轨、音频运算放大器



1 特性

- 低噪声：
频率为 10kHz 时为 $4\text{nV}/\sqrt{\text{Hz}}$
频率为 1kHz 时为 $4.7\text{fA}/\sqrt{\text{Hz}}$
- 低失真：-109dB (0.00035%)
- 宽增益带宽：13MHz
- 轨至轨输入和输出
- 低电源电压运行范围：1.7V 至 5.5V
- 低输入电容
 - 差模：6pF
 - 共模：2.5pF
- 低输入偏置电流：10pA
- 低功耗电源电流：940 μA
- 行业标准封装：SC-70 和 SOT-23

2 应用

- 麦克风前置放大器
- 辅助线路输入和输出
- 有源滤波器电路
- 跨阻放大器
- 电压缓冲器

驻极体麦克风前置放大器

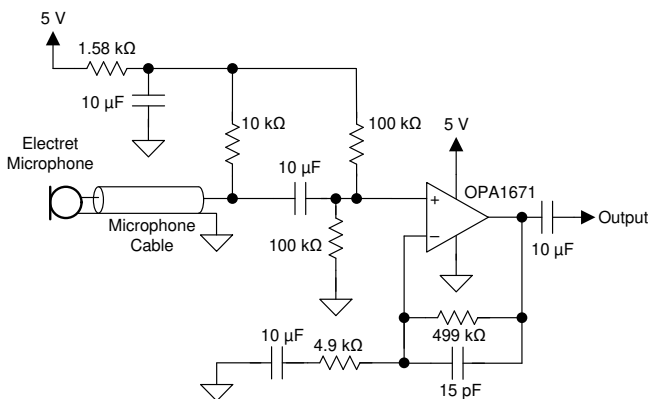

3 说明

OPA1671 是一款宽带宽、低噪声、低失真音频运算放大器，可提供轨至轨输入和输出操作。该器件可提供低电压噪声、电流噪声和输入电容的完美组合，从而能够在各种音频和工业应用中提供高性能。OPA1671 的独特内部拓扑可提供极低的失真 (-109dB)，同时仅消耗 940 μA 的电源电流。OPA1671 的高带宽 (13MHz) 和高压摆率 (5V/ μs) 使该器件成为高增益音频和工业信号调节的绝佳选择。

OPA1671 采用 SC-70 和 SOT-23 封装，可在 -40°C 至 $+125^{\circ}\text{C}$ 的工业温度范围内正常工作。

器件信息⁽¹⁾

器件型号	封装	封装尺寸 (标称值)
OPA1671	SC-70 (5)	2.00mm × 1.25mm
	SOT-23 (5)	2.90mm × 1.60mm

(1) 如需了解所有可用封装，请参阅数据表末尾的封装选项附录。

OPA1671 电压噪声密度

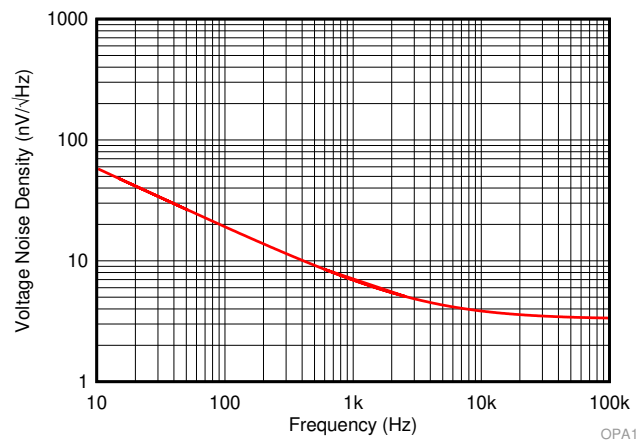

OPA1



目录

1	特性	1	8	Application and Implementation	15
2	应用	1	8.1	Application Information.....	15
3	说明	1	8.2	Typical Application	17
4	修订历史记录	2	9	Power Supply Recommendations	19
5	Pin Configuration and Functions	3	10	Layout.....	19
6	Specifications.....	4	10.1	Layout Guidelines	19
6.1	Absolute Maximum Ratings	4	10.2	Layout Example	19
6.2	ESD Ratings.....	4	11	器件和文档支持	20
6.3	Recommended Operating Conditions.....	4	11.1	器件支持	20
6.4	Thermal Information	4	11.2	文档支持	20
6.5	Electrical Characteristics.....	5	11.3	接收文档更新通知	20
6.6	Typical Characteristics	7	11.4	社区资源	20
7	Detailed Description	12	11.5	商标	21
7.1	Overview	12	11.6	静电放电警告	21
7.2	Functional Block Diagram	12	11.7	Glossary	21
7.3	Feature Description.....	13	12	机械、封装和可订购信息	21
7.4	Device Functional Modes.....	14			

4 修订历史记录

注：之前版本的页码可能与当前版本有所不同。

Changes from Revision A (January 2019) to Revision B	Page
• 已添加 向数据表中添加了 SOT-23 (DBV) 封装和相关内容	1
• Added input offset voltage specification for $V_{CM} = (V+), (V-)$	5

Changes from Original (November 2018) to Revision A	Page
• 已更改 将预告信息（预览）更改为生产数据（正在供货）	1

5 Pin Configuration and Functions

**DBV and DCK Packages
5-Pin SOT-23 and SC-70
Top View**

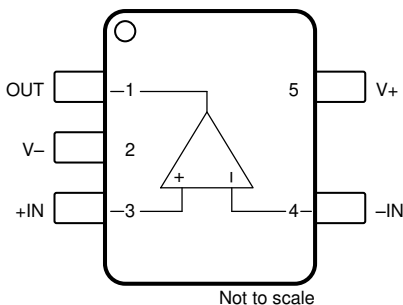

Pin Functions

PIN		I/O	DESCRIPTION
NAME	NO.		
-IN	4	I	Inverting input
+IN	3	I	Noninverting input
OUT	1	O	Output
V-	2	—	Negative (lowest) power supply
V+	5	—	Positive (highest) power supply

6 Specifications

6.1 Absolute Maximum Ratings

over operating free-air temperature range (unless otherwise noted)⁽¹⁾

	MIN	MAX	UNIT
Supply voltage, $V_S = (V+) - (V-)$		6	V
Input voltage	(V-) -0.3	(V+) +0.3	V
Output short-circuit ⁽²⁾	Continuous		
Operating temperature, T_A	-55	150	°C
Storage temperature, T_{stg}	-65	150	°C

- (1) Stresses beyond those listed under *Absolute Maximum Ratings* may cause permanent damage to the device. These are stress ratings only, which do not imply functional operation of the device at these or any other conditions beyond those indicated under *Recommended Operating Conditions*. Exposure to absolute-maximum-rated conditions for extended periods may affect device reliability.
- (2) Short-circuit to ground, one amplifier per package.

6.2 ESD Ratings

			VALUE	UNIT
$V_{(ESD)}$	Electrostatic discharge	Human-body model (HBM), per ANSI/ESDA/JEDEC JS-001 ⁽¹⁾	2000	V
		Charged-device model (CDM), per JEDEC specification JESD22-C101 ⁽²⁾	500	

- (1) JEDEC document JEP155 states that 500-V HBM allows safe manufacturing with a standard ESD control process.
- (2) JEDEC document JEP157 states that 250-V CDM allows safe manufacturing with a standard ESD control process.

6.3 Recommended Operating Conditions

over operating free-air temperature range (unless otherwise noted)

	MIN	NOM	MAX	UNIT
Supply voltage, $V_S = (V+) - (V-)$	1.7 (± 0.85)		5.5 (± 2.75)	V
Specified temperature, T_A	-40		125	°C

6.4 Thermal Information

THERMAL METRIC ⁽¹⁾		OPA1671		UNIT
		DBV (SOT-23)	DCK (SC-70)	
		5 PINS	5 PINS	
$R_{\theta JA}$	Junction-to-ambient thermal resistance	187.1	214.7	°C/W
$R_{\theta JC(top)}$	Junction-to-case (top) thermal resistance	107.4	127.1	°C/W
$R_{\theta JB}$	Junction-to-board thermal resistance	57.5	60.0	°C/W
Ψ_{JT}	Junction-to-top characterization parameter	33.5	33.4	°C/W
Ψ_{JB}	Junction-to-board characterization parameter	57.1	59.8	°C/W
$R_{\theta JC(bot)}$	Junction-to-case (bottom) thermal resistance	n/a	n/a	°C/W

- (1) For more information about traditional and new thermal metrics, see the [Semiconductor and IC Package Thermal Metrics](#) application report.

6.5 Electrical Characteristics

at $V_S = \pm 0.85\text{ V}$ to $\pm 2.75\text{ V}$ ($V_S = 1.7\text{ V}$ to 5.5 V), $T_A = 25^\circ\text{C}$, $R_L = 10\text{ k}\Omega$ connected to $V_S / 2$, $V_{CM} = V_S / 2$, and $V_{OUT} = V_S / 2$ (unless otherwise noted)

PARAMETER		TEST CONDITIONS		MIN	TYP	MAX	UNIT	
AUDIO PERFORMANCE								
THD+N	Total harmonic distortion + noise	$G = 1$, $f = 1\text{ kHz}$, $V_O = 1\text{ V}_{RMS}$, $V_S = 5.5\text{ V}$		0.00035%				
					-109		dB	
IMD	Intermodulation distortion	$G = 1$, $V_O = 1\text{ V}_{RMS}$, $V_S = 5.5\text{ V}$	SMPTE/DIN Two-Tone, 4:1, (60 Hz and 7 kHz)	0.00158%				
						-96	dB	
				0.0005%				
			CCIF Two-Tone (19 kHz and 20 kHz)		-106		dB	
FREQUENCY RESPONSE								
GBW	Gain-bandwidth product			13			MHz	
SR	Slew rate	4-V step, $G = 1$		5			V/ μs	
t_S	Settling time	T_O 0.1%, 2-V step, $G = 1$		0.75			μs	
		T_O 0.01%, 2-V step, $G = 1$		1				
	Overload recovery time	$V_{IN} \times \text{gain} > V_S$		0.35			μs	
NOISE								
	Input voltage noise	$f = 0.1\text{ Hz}$ to 10 Hz		2.4			μV_{PP}	
e_N	Input voltage noise density	$f = 10\text{ Hz}$		45			$\text{nV}/\sqrt{\text{Hz}}$	
		$f = 1\text{ kHz}$		7				
		$f = 10\text{ kHz}$		4.0				
i_N	Input current noise	$f = 1\text{ kHz}$		4.7			$\text{fA}/\sqrt{\text{Hz}}$	
OFFSET VOLTAGE								
V_{OS}	Input offset voltage	$V_{CM} = (V_+)$				± 1.6	mV	
		$V_{CM} = (V_-)$				± 1.6		
		$T_A = -40^\circ\text{C}$ to 125°C				± 0.25		± 1.25
dV_{OS}/dT	Input offset voltage drift	$T_A = -40^\circ\text{C}$ to 125°C				± 0.3	± 2.2	
PSRR	Input offset voltage versus power supply	$V_{CM} = (V_-)$				± 30	± 130	
INPUT BIAS CURRENT								
I_B	Input bias current					± 10	pA	
I_{OS}	Input offset current					± 10		
INPUT VOLTAGE RANGE								
V_{CM}	Common-mode voltage range			V_-		V_+	V	
CMRR	Common-mode rejection ratio	$V_S = 1.7\text{ V}$, $(V_-) < V_{CM} < (V_+) - 1.25\text{ V}$		74	91		dB	
		$V_S = 5.5\text{ V}$, $(V_-) < V_{CM} < (V_+) - 1.25\text{ V}$		80	96			
		$V_S = 1.7\text{ V}$, $V_{CM} = 0\text{ V}$ to 1.7 V		60	88			
		$V_S = 5.5\text{ V}$, $V_{CM} = 0\text{ V}$ to 5.5 V		68	102			
INPUT CAPACITANCE								
Z_{ID}	Differential			$10^{13} \parallel 6$			$\text{M}\Omega \parallel \text{pF}$	
Z_{ICM}	Common-mode			$10^{13} \parallel 2.5$			$\text{G}\Omega \parallel \text{pF}$	
OPEN-LOOP GAIN								
A_{OL}	Open-loop voltage gain	$(V_-) + 50\text{ mV} < V_O < (V_+) - 50\text{ mV}$, $R_L = 10\text{ k}\Omega$				97	113	dB
				$T_A = -40^\circ\text{C}$ to 125°C				
		$(V_-) + 200\text{ mV} < V_O < (V_+) - 200\text{ mV}$, $R_L = 2\text{ k}\Omega$				97	112	
				$T_A = -40^\circ\text{C}$ to 125°C				

Electrical Characteristics (continued)

at $V_S = \pm 0.85\text{ V to } \pm 2.75\text{ V}$ ($V_S = 1.7\text{ V to } 5.5\text{ V}$), $T_A = 25^\circ\text{C}$, $R_L = 10\text{ k}\Omega$ connected to $V_S / 2$, $V_{CM} = V_S / 2$, and $V_{OUT} = V_S / 2$ (unless otherwise noted)

PARAMETER		TEST CONDITIONS	MIN	TYP	MAX	UNIT
OUTPUT						
	Voltage output swing from rail	$V_S = 5.5\text{ V}$, $R_L = 10\text{ k}\Omega$		10	20	mV
I_{SC}	Short-circuit current	Sinking, $V_S = 5.5\text{ V}$		-57		mA
		Sourcing, $V_S = 5.5\text{ V}$		66		
POWER SUPPLY						
I_Q	Quiescent current per amplifier	$I_O = 0\text{ mA}$		0.94	1.3	mA
		$I_O = 0\text{ mA}$, $T_A = -40^\circ\text{C to } 125^\circ\text{C}$			1.4	

6.6 Typical Characteristics

at $T_A = 25^\circ\text{C}$, $V_S = \pm 2.5\text{ V}$, $V_{CM} = V_S / 2$, $R_L = 10\text{ k}\Omega$ connected to $V_S / 2$ (unless otherwise noted)



图 1. Offset Voltage Production Distribution



图 2. Offset Voltage Production Distribution

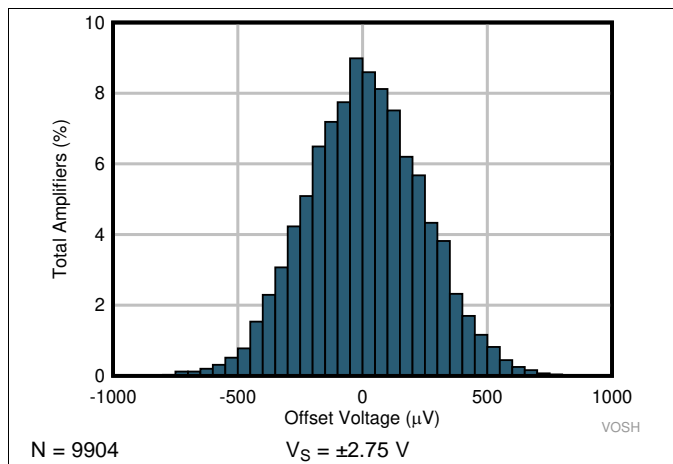

图 3. Offset Voltage Drift Distribution

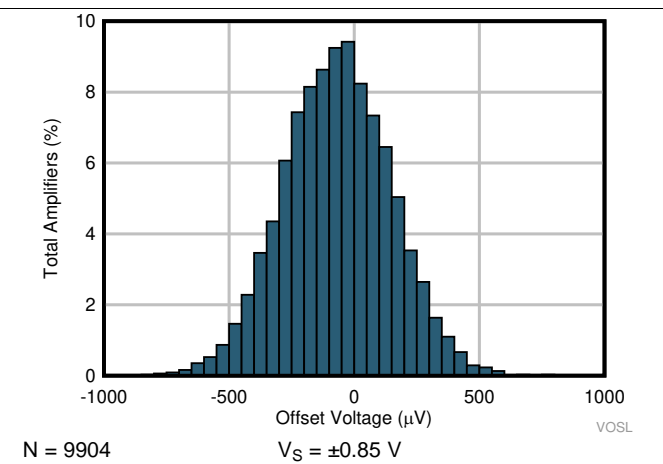

图 4. Offset Voltage vs Temperature

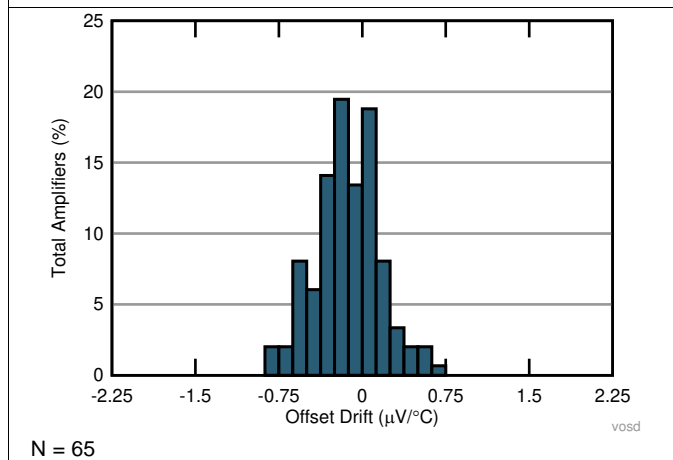

图 5. Offset Voltage vs Common Mode Voltage

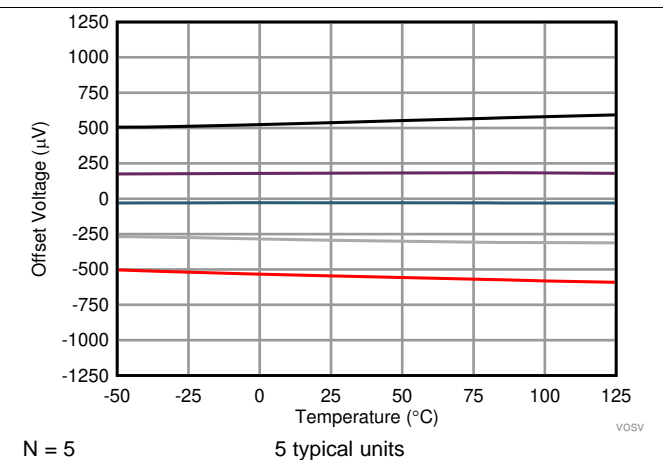

图 6. Open-Loop Gain and Phase vs Frequency

Typical Characteristics (接下页)

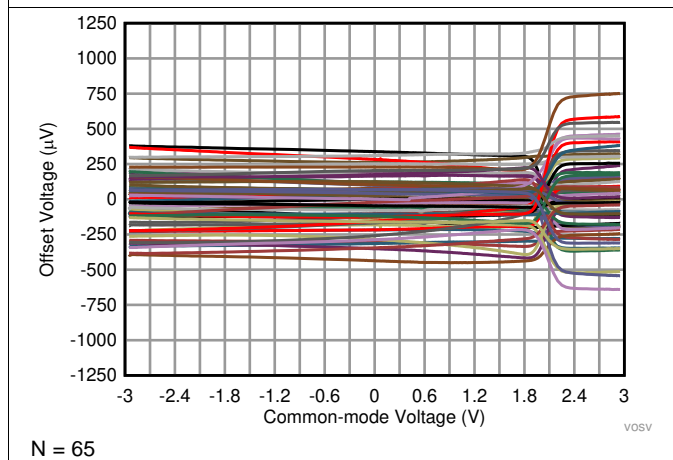
at $T_A = 25^\circ\text{C}$, $V_S = \pm 2.5\text{ V}$, $V_{CM} = V_S / 2$, $R_L = 10\text{ k}\Omega$ connected to $V_S / 2$ (unless otherwise noted)

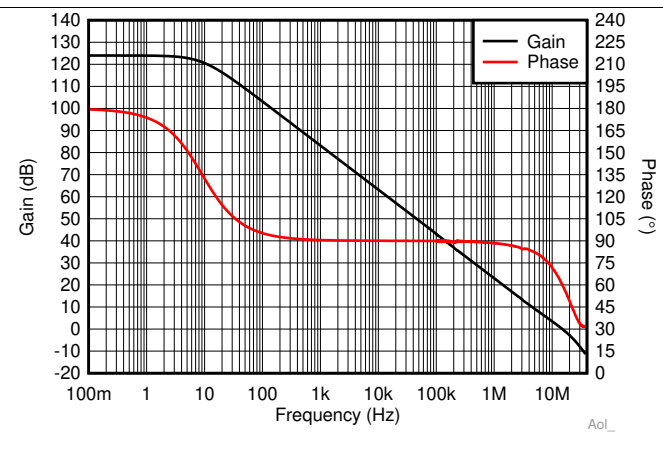
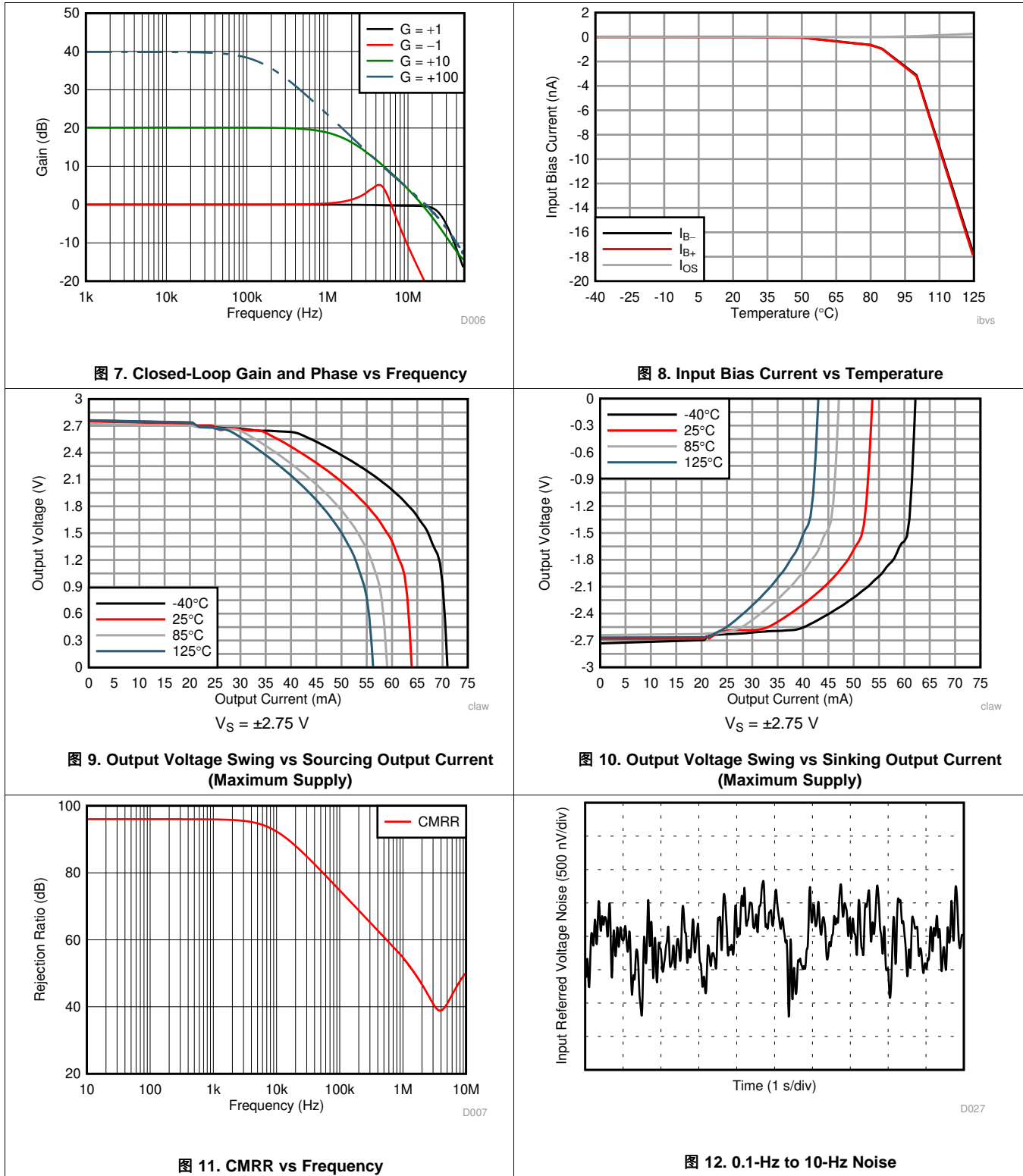

Typical Characteristics (接下页)

at $T_A = 25^\circ\text{C}$, $V_S = \pm 2.5\text{ V}$, $V_{CM} = V_S / 2$, $R_L = 10\text{ k}\Omega$ connected to $V_S / 2$ (unless otherwise noted)

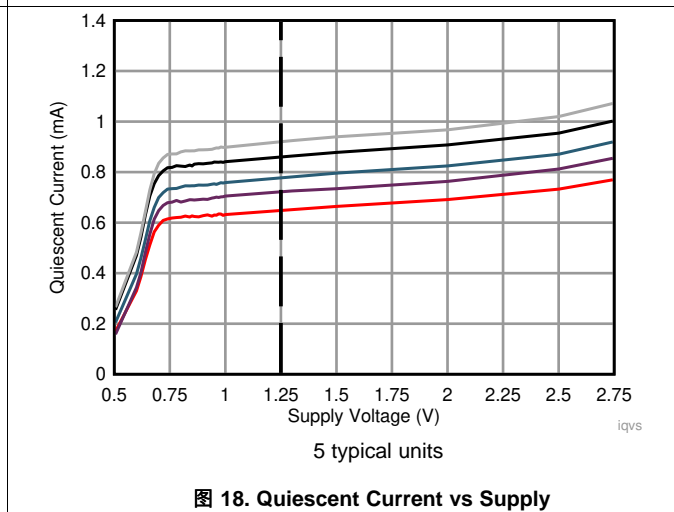
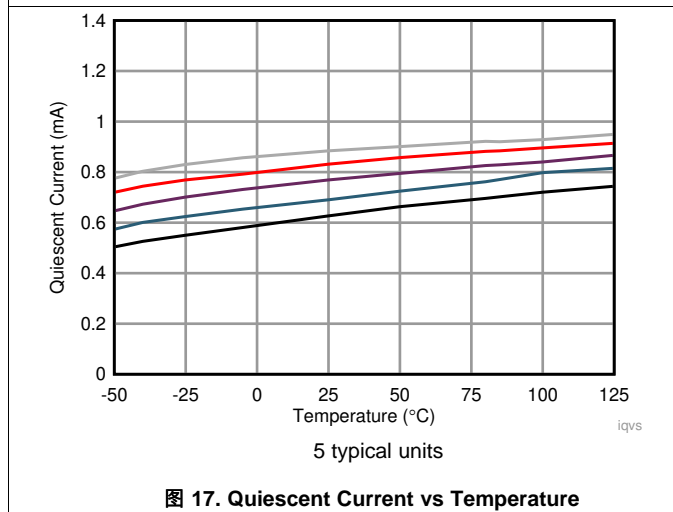
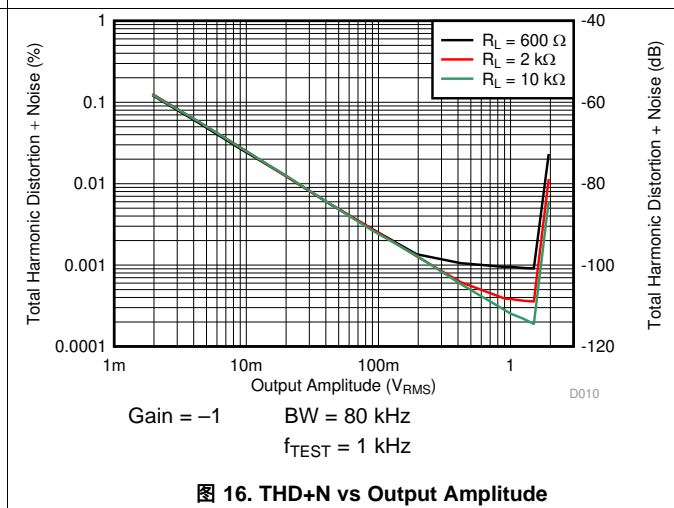
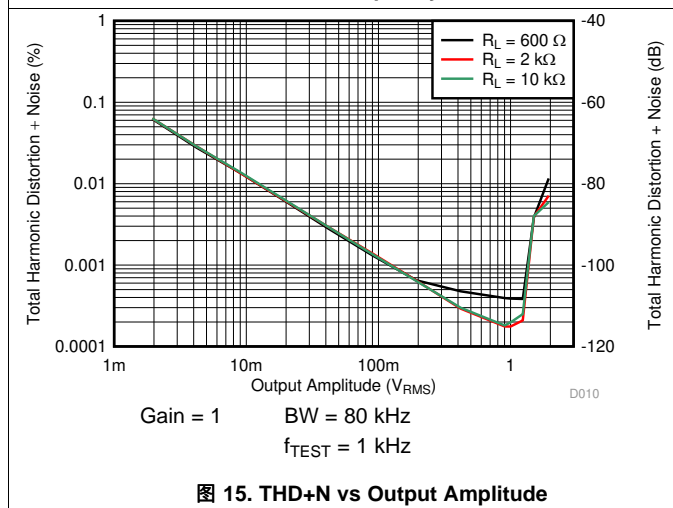
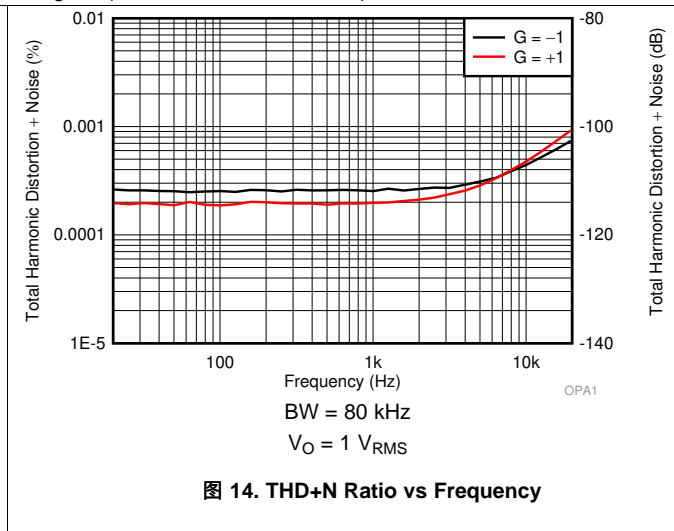
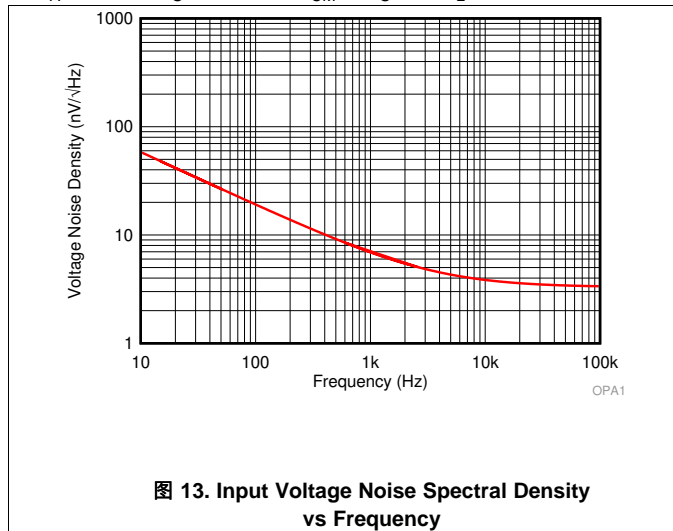

Typical Characteristics (接下页)

at $T_A = 25^\circ\text{C}$, $V_S = \pm 2.5\text{ V}$, $V_{CM} = V_S / 2$, $R_L = 10\text{ k}\Omega$ connected to $V_S / 2$ (unless otherwise noted)

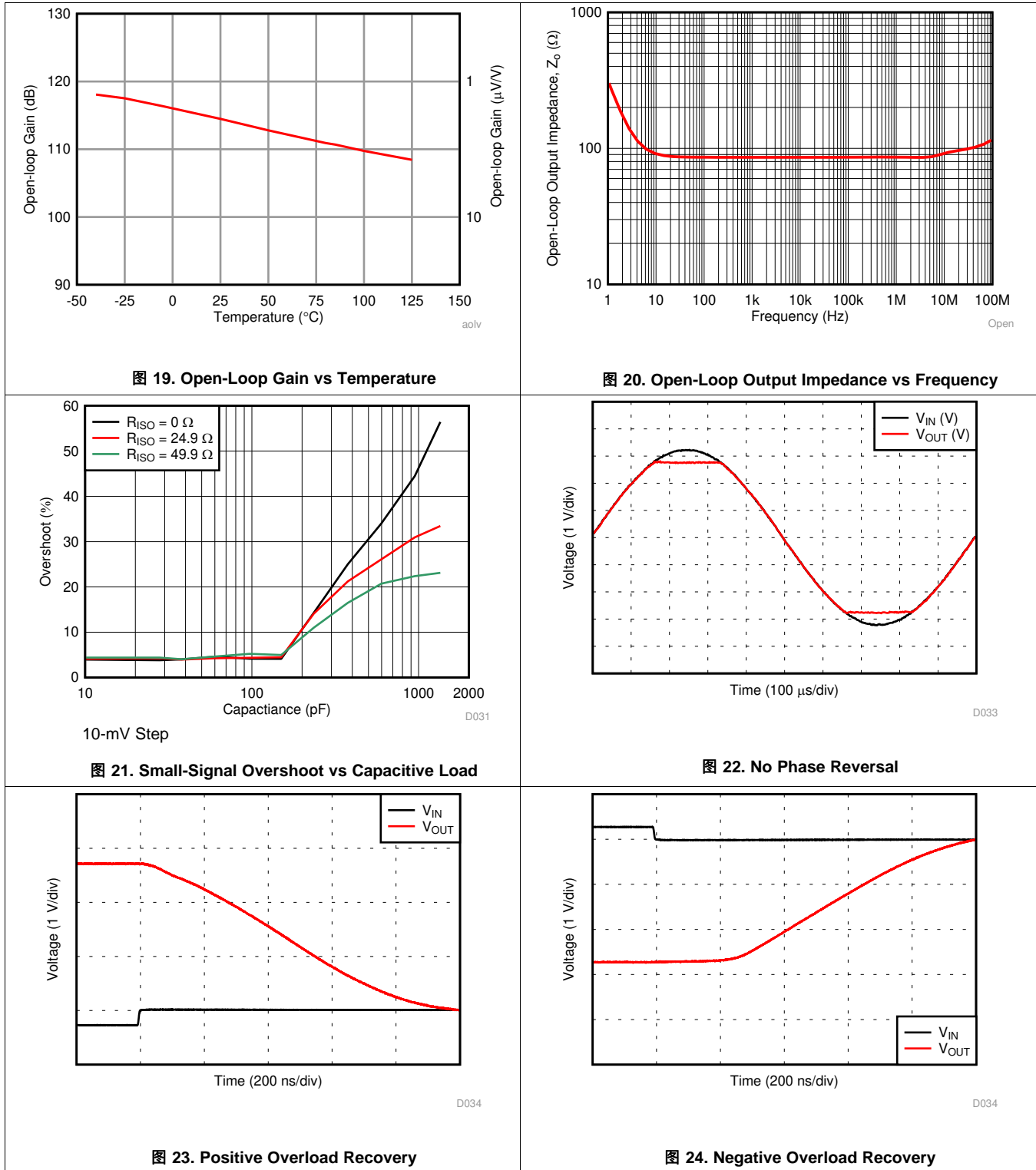

Typical Characteristics (接下页)

at $T_A = 25^\circ\text{C}$, $V_S = \pm 2.5\text{ V}$, $V_{CM} = V_S / 2$, $R_L = 10\text{ k}\Omega$ connected to $V_S / 2$ (unless otherwise noted)

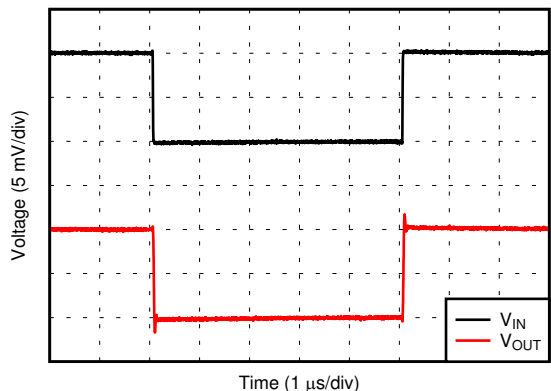

10-mV step $G = +1$

D035

图 25. Small-Signal Step Response

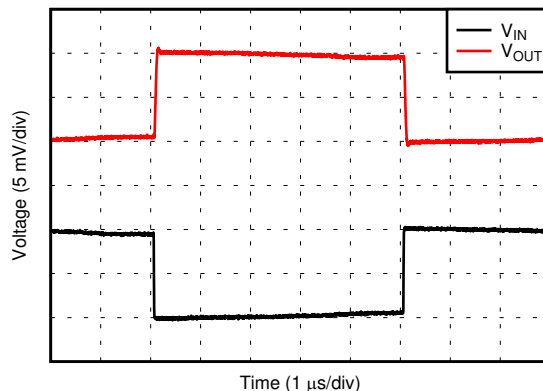

10-mV step $G = -1$

D035

图 26. Small-Signal Step Response

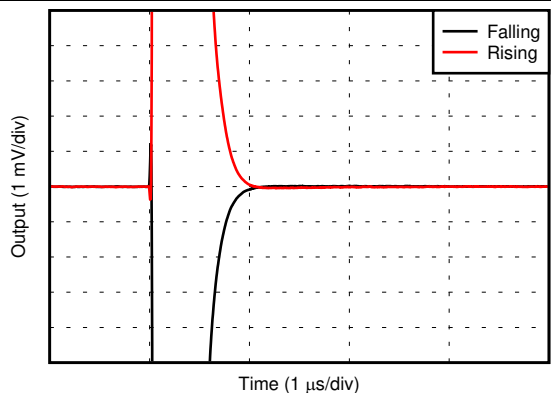

2-V Step

D037

图 27. Settling Time

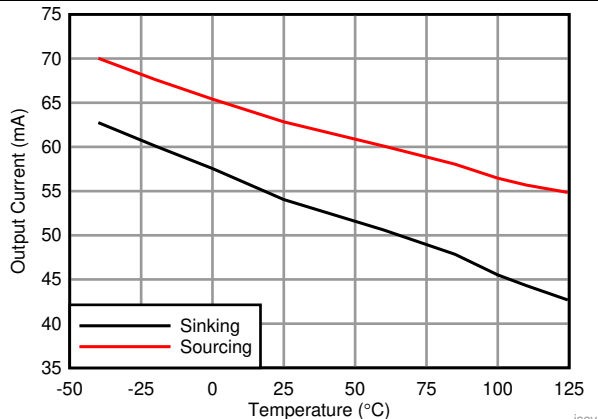

iscv

图 28. Short-Circuit Current vs Temperature

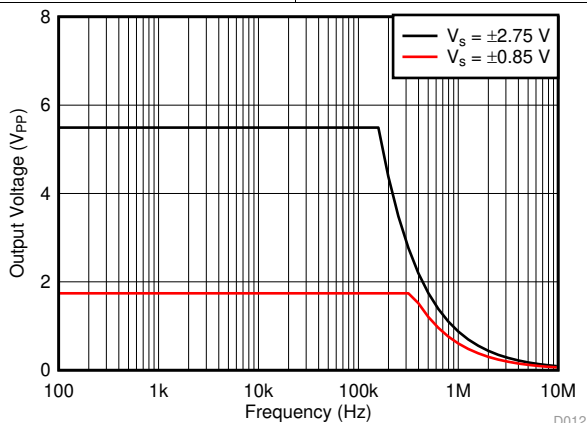

D012

图 29. Maximum Output Voltage vs Frequency

7 Detailed Description

7.1 Overview

The OPA1671 is a rail-to-rail input, very low noise operational amplifier (op amp). The OPA1671 operates from 1.7 V to 5.5 V, is unity-gain stable, and is designed for a wide range of audio and general-purpose applications. The OPA1671 strengths also include 13-MHz bandwidth and 4.0-nV/ $\sqrt{\text{Hz}}$ noise spectral density, with very low input bias current (10 pA). These strengths make the OPA1671 a great choice for a preamplifier in microphone circuits, sensor modules and buffering high-fidelity, digital-to-analog converters (DACs).

7.2 Functional Block Diagram

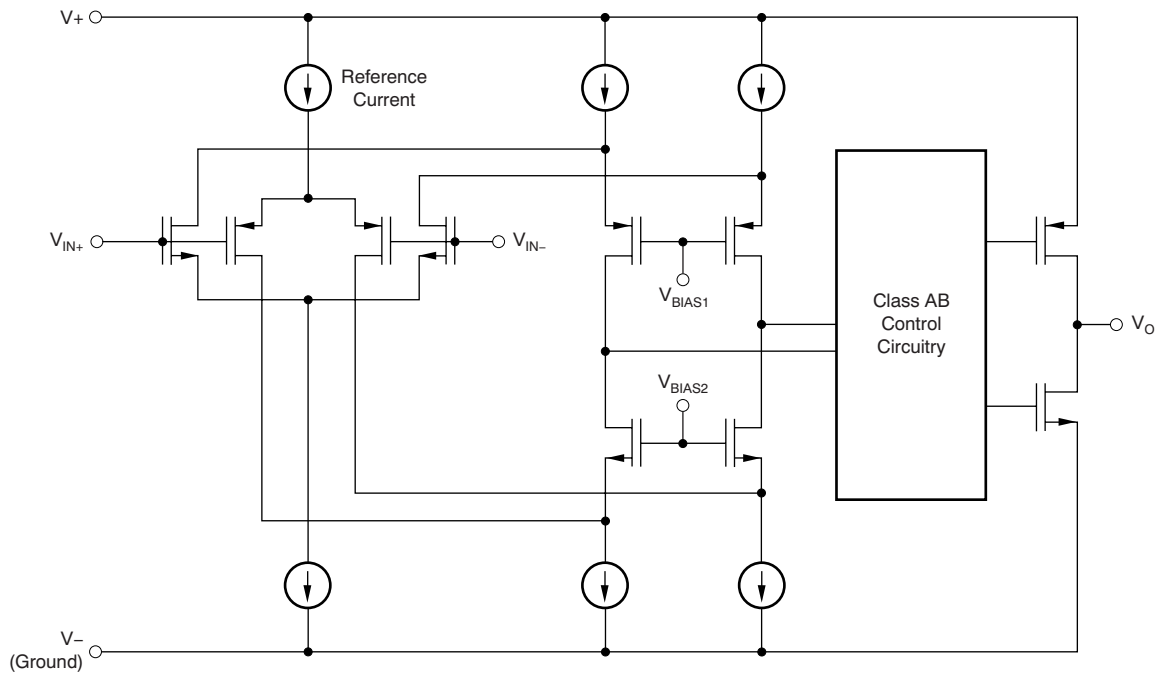

7.3 Feature Description

7.3.1 Operating Voltage

The OPA1671 op amp can be used with single or dual supplies from an operating range of $V_S = 1.7\text{ V}$ ($\pm 0.85\text{ V}$) up to 5.5 V ($\pm 2.75\text{ V}$).

CAUTION

Supply voltages greater than 6 V can permanently damage the device (see [Absolute Maximum Ratings](#))

Key parameters that vary over the supply voltage or temperature range are shown in the [Typical Characteristics](#) section.

7.3.2 Input Bias Current

Typically, input bias current is approximately $\pm 10\text{ pA}$. Input voltages exceeding the power supplies, however, can cause excessive current to flow into or out of the input pins. Momentary voltages greater than the power supply can be tolerated if the input current is limited to 10 mA . This limitation is easily accomplished with an input resistor, as shown in [Figure 30](#).

Unlike many operational amplifiers, there are no diodes connected between the positive and negative input terminals. As a result, differential voltages up to the full supply voltage do not cause any significantly higher current flow into the inputs.



图 30. Input Current Protection

7.3.3 Common-Mode Voltage Range

The OPA1671 features true rail-to-rail inputs, allowing full common mode operation from the negative supply voltage to the positive supply voltage. This full common mode operation is achieved with complimentary N-channel and P-channel differential input pairs. The N-channel pair is active for input voltages close to the positive rail, typically $(V+) - 1.25\text{ V}$ to $(V+)$. The P-channel is active for common-mode inputs from $(V-)$ to $(V+) - 1.25\text{ V}$. There is a small transition region, typically from $(V+) - 1.25\text{ V}$ to $(V+) - 1\text{ V}$. In this region, the offset voltage transitions between the P-channel and N-channel offset values. [Figure 5](#) shows the difference between offset in the P and N regions.

Feature Description (接下页)

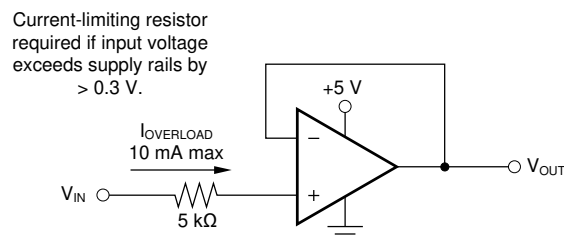
7.3.4 EMI Susceptibility and Input Filtering

Operational amplifiers vary in susceptibility to EMI. If conducted EMI enters the operational amplifier, the dc offset at the amplifier output can shift from its nominal value when EMI is present. This shift is a result of signal rectification associated with the internal semiconductor junctions. Although all operational amplifier pin functions can be affected by EMI, the input pins are likely to be the most susceptible. The OPA1671 operational amplifier incorporates an internal input low-pass filter that reduces the amplifier response to EMI. Both common-mode and differential-mode filtering are provided by the input filter. The filter is designed for a cutoff frequency of approximately 20 MHz (–3 dB), with a rolloff of 20 dB per decade.



图 31. OPA1671 EMIRR vs Frequency

表 1. OPA1671 EMIRR IN+ for Frequencies of Interest

FREQUENCY	APPLICATION OR ALLOCATION	EMIRR IN+
400 MHz	Mobile radio, mobile satellite, space operation, weather, radar, ultra-high frequency (UHF) applications	30 dB
900 MHz	Global system for mobile communications (GSM) applications, radio communication, navigation, GPS (to 1.6 GHz), GSM, aeronautical mobile, UHF applications	38 dB
1.8 GHz	GSM applications, mobile personal communications, broadband, satellite, L-band (1 GHz to 2 GHz)	60 dB
2.4 GHz	802.11b, 802.11g, 802.11n, Bluetooth®, mobile personal communications, industrial, scientific and medical (ISM) radio band, amateur radio and satellite, S-band (2 GHz to 4 GHz)	59 dB
3.6 GHz	Radiolocation, aero communication and navigation, satellite, mobile, S-band	90 dB
5 GHz	802.11a, 802.11n, aero communication and navigation, mobile communication, space and satellite operation, C-band (4 GHz to 8 GHz)	100 dB

7.4 Device Functional Modes

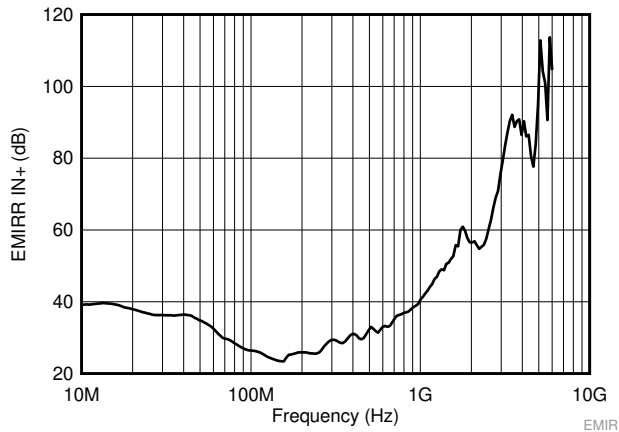
The OPA1671 has a single functional mode and is operational when the power-supply voltage is greater than 1.7 V (± 0.85 V). The maximum specified power-supply voltage for the OPA1671 is 5.5 V (± 2.75 V).

8 Application and Implementation

注

Information in the following applications sections is not part of the TI component specification, and TI does not warrant its accuracy or completeness. TI's customers are responsible for determining suitability of components for their purposes. Customers should validate and test their design implementation to confirm system functionality.

8.1 Application Information

The OPA1671 is a low-noise, rail-to-rail input and output operational amplifier specifically designed for portable applications. The device operates from 1.7 V to 5.5 V, is unity-gain stable, and suitable for a wide range of audio and general-purpose applications. The class AB output stage is capable of driving $\leq 10\text{-k}\Omega$ loads connected to any point between $V+$ and ground. The input common-mode voltage range includes both rails, and allows the OPA1671 device to be used in virtually any single-supply application. Rail-to-rail input and output swing significantly increases dynamic range, especially in low-supply applications, and makes the device a great choice for driving sampling analog-to-digital converters (ADCs).

8.1.1 Capacitive Loads

The dynamic characteristics of the OPA1671 amplifiers are optimized for commonly encountered gains, loads, and operating conditions. The combination of low closed-loop gain and high capacitive loads decreases the phase margin of the amplifier and can lead to gain peaking or oscillations. As a result, heavier capacitive loads must be isolated from the output. Add a small resistor (for example, $R_S = 50\ \Omega$) in series with the output to isolate heavier capacitive loads.

8.1.2 Noise Performance

图 31 shows the total circuit noise for varying source impedances with the operational amplifier in a unity-gain configuration (with no feedback resistor network and therefore no additional noise contributions). The op amp itself contributes a voltage noise component and a current noise component. The voltage noise is commonly modeled as a time-varying component of the offset voltage. The current noise is modeled as the time-varying component of the input bias current and reacts with the source resistance to create a voltage component of noise. For a CMOS-input device, the noise resulting from the input current is negligible; therefore, the total noise is dominated by the voltage noise of the OPA1671 at low source resistance, and the resistor noise $> 1\ \text{k}\Omega$.

图 31 shows the calculation of the total circuit noise, with these parameters:

- e_n = voltage noise
- R_S = source impedance
- k = Boltzmann's constant = $1.38 \times 10^{-23}\ \text{J/K}$
- T = temperature in kelvins (K)

For more details on calculating noise, see [Basic Noise Calculations](#).



图 32. Noise Performance of the OPA1671 in a Unity-Gain Buffer Configuration

Application Information (接下页)

8.1.3 Basic Noise Calculations

Low-noise circuit design requires careful analysis of all noise sources. External noise sources can dominate in many cases; consider the effect of source resistance on overall op amp noise performance. Total noise of the circuit is the root-sum-square combination of all noise components.

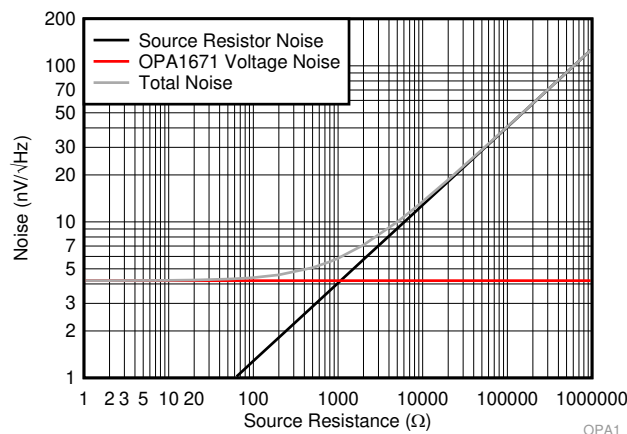
The resistive portion of the source impedance produces thermal noise proportional to the square root of the resistance. This function is plotted in [图 31](#). The source impedance is typically fixed; consequently, select the op amp and the feedback resistors to minimize the respective contributions to the total noise.

[图 33](#) shows noninverting **(A)** and inverting **(B)** op amp circuit configurations with gain. In circuit configurations with gain, the feedback network resistors contribute noise. In general, the current noise of the op amp reacts with the feedback resistors to create additional noise components.

The selected feedback resistor values make these noise sources negligible. Low impedance feedback resistors load the output of the amplifier. The equations for total noise are shown for both configurations.

(A) Noise in Noninverting Gain Configuration

Noise at the output is given as E_o , where

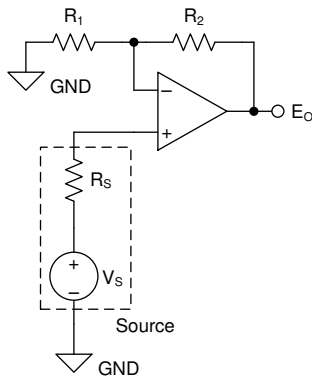

$$(1) E_o = \left(1 + \frac{R_2}{R_1}\right) \cdot \sqrt{(e_s)^2 + (e_N)^2 + (e_{R_1 \parallel R_2})^2 + (i_N \cdot R_S)^2 + \left(i_N \cdot \left[\frac{R_1 \cdot R_2}{R_1 + R_2}\right]\right)^2} \quad [V_{RMS}]$$

$$(2) e_s = \sqrt{4 \cdot k_B \cdot T(K) \cdot R_S} \quad \left[\frac{V}{\sqrt{Hz}}\right] \quad \text{Thermal noise of } R_S$$

$$(3) e_{R_1 \parallel R_2} = \sqrt{4 \cdot k_B \cdot T(K) \cdot \left[\frac{R_1 \cdot R_2}{R_1 + R_2}\right]} \quad \left[\frac{V}{\sqrt{Hz}}\right] \quad \text{Thermal noise of } R_1 \parallel R_2$$

$$(4) k_B = 1.38065 \cdot 10^{-23} \quad \left[\frac{J}{K}\right] \quad \text{Boltzmann Constant}$$

$$(5) T(K) = 237.15 + T(^{\circ}C) \quad [K] \quad \text{Temperature in kelvins}$$

(B) Noise in Inverting Gain Configuration

Noise at the output is given as E_o , where

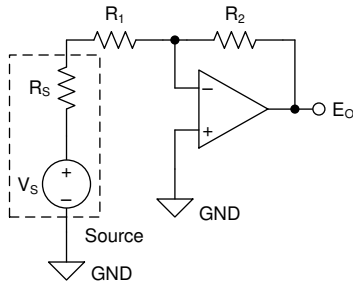

$$(6) E_o = \left(1 + \frac{R_2}{R_S + R_1}\right) \cdot \sqrt{(e_N)^2 + (e_{R_1 + R_S \parallel R_2})^2 + \left(i_N \cdot \left[\frac{(R_S + R_1) \cdot R_2}{R_S + R_1 + R_2}\right]\right)^2} \quad [V_{RMS}]$$

$$(7) e_{R_1 + R_S \parallel R_2} = \sqrt{4 \cdot k_B \cdot T(K) \cdot \left[\frac{(R_S + R_1) \cdot R_2}{R_S + R_1 + R_2}\right]} \quad \left[\frac{V}{\sqrt{Hz}}\right] \quad \text{Thermal noise of } (R_1 + R_S) \parallel R_2$$

$$(8) k_B = 1.38065 \cdot 10^{-23} \quad \left[\frac{J}{K}\right] \quad \text{Boltzmann Constant}$$

$$(9) T(K) = 237.15 + T(^{\circ}C) \quad [K] \quad \text{Temperature in kelvins}$$

Copyright © 2017, Texas Instruments Incorporated

- (1) e_N is the voltage noise of the amplifier. For the OPA1671 series of operational amplifiers, $e_N = 4.0 \text{ nV}/\sqrt{\text{Hz}}$ at 10 kHz.
- (2) i_N is the current noise of the amplifier. For the OPA1671 series of operational amplifiers, $i_N = 4.5 \text{ fA}/\sqrt{\text{Hz}}$ at 1 kHz.
- (3) For additional resources on noise calculations, see [TI's Precision Labs Series](#).

图 33. Noise Calculation in Gain Configurations

8.2 Typical Application

This design uses an OPA1671 as a preamplifier for an electret microphone. Electret microphone types are common in many audio applications of varying performance levels. The OPA1671 offers very low noise in a tiny package, and is designed for use in electret preamplifier circuits.

图 34 shows the solution.



图 34. Electret Preamplifier Schematic

8.2.1 Design Requirements

This solution has the following requirements:

- Supply voltage: 5 V
- Gain: 100 V/V
- Frequency response: 3 dB from 20 Hz to 20 kHz
- Output: 2.5 V ±1 V
- Output noise density: < 1 μV/√Hz at 10 kHz

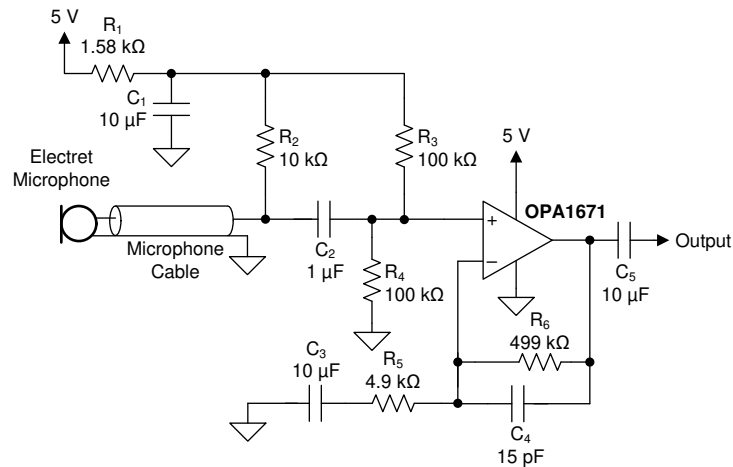
Typical Application (接下页)

8.2.2 Detailed Design Procedure

The preamplifier circuit uses a noninverting gain configuration to allow for high input impedance, with independent gain-setting resistor values. DC bypass is accomplished with C_2 and C_3 , with the low frequency poles set by C_2 , R_4 , C_3 and R_5 ; see [公式 1](#) and [公式 2](#).

$$p_{L1} = \frac{1}{2\pi \cdot (R_3 \parallel R_4) \cdot C_2} = 3.18 \text{ Hz} \tag{1}$$

$$p_{L2} = \frac{1}{2\pi \cdot R_5 \cdot C_2} = 3.23 \text{ Hz} \tag{2}$$

The filter cutoff frequency is determined by a higher frequency pole, set by R_5 and C_4 .

$$p_H = \frac{1}{2\pi \cdot R_6 \cdot C_4} = 21.3 \text{ kHz} \tag{3}$$

The gain of the circuit in the passband is set by R_5 and R_6 .

$$A(V/V) = \frac{R_6}{R_5} = 100 (40 \text{ dB}) \tag{4}$$

The output noise of the circuit (ignoring the electret microphone intrinsic noise and impedance) is the RSS average noise contribution from R_5 and the input voltage noise of OPA1671. R_5 was selected for minimal noise contribution without requiring a dc blocking cap. (C_3) larger than 10 μF . See [公式 5](#) for the output noise density calculation at 10 kHz.

$$e_{N_OUT} = \text{Input Referred Noise} \cdot \text{Gain} = \sqrt{(4kTR_5)^2 + V_{N_10k}^2} \cdot 100 = 0.96 \mu\text{V}/\sqrt{\text{Hz}} \tag{5}$$

8.2.3 Application Curves

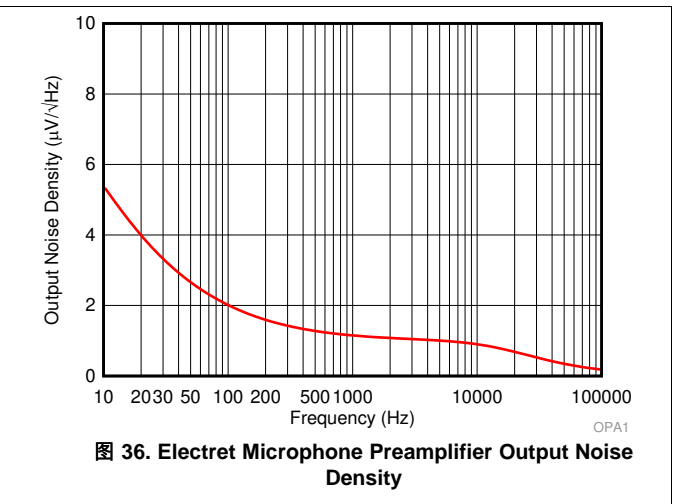
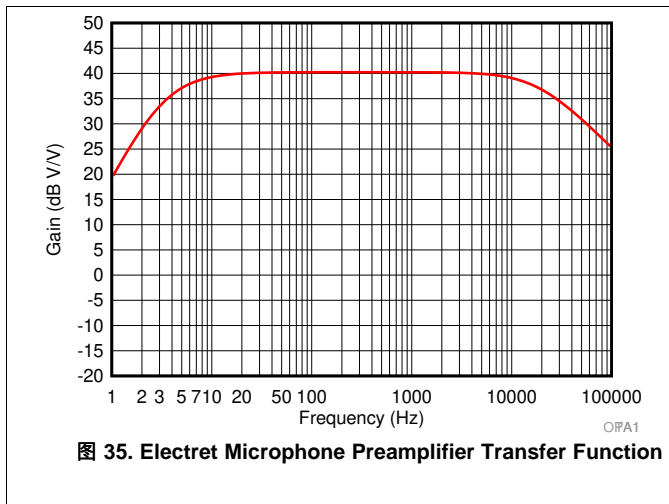

9 Power Supply Recommendations

The OPA1671 device is specified for operation from 1.7 V to 5.5 V (± 0.85 V to ± 2.75 V).

10 Layout

10.1 Layout Guidelines

Paying attention to good layout practice is always recommended. Keep traces short and, when possible, use a printed-circuit board (PCB) ground plane with surface-mount components placed as close to the device pins as possible. Place a 0.1- μ F capacitor closely across the supply pins. These guidelines must be applied throughout the analog circuit to improve performance and provide benefits such as reducing the electromagnetic interference (EMI) susceptibility.

10.2 Layout Example



图 37. OPA1671 Layout Example

11 器件和文档支持

11.1 器件支持

11.1.1 开发支持

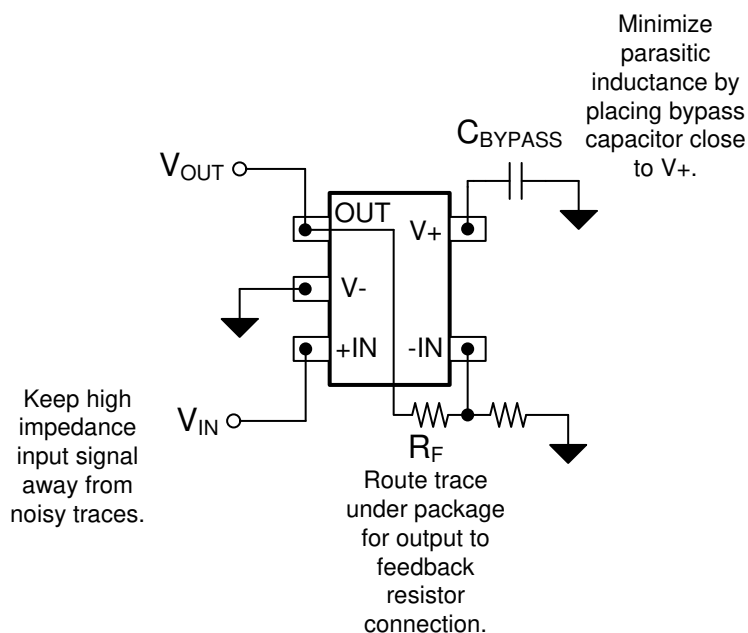
11.1.1.1 TINA-TI™ (免费下载)

TINA-TI™ 是一款基于 SPICE 引擎的电路仿真程序，简单易用并且功能强大。TINA-TI™ 是 TINA™ 软件的一款免费全功能版本，除了一系列无源和有源模型外，此版本软件还预先载入了一个宏模型库。TINA-TI™ 提供所有传统的 SPICE 直流、瞬态和频域分析，以及其他设计功能。

TINA-TI™ 提供全面的后处理能力，便于用户以多种方式获得结果，用户可从 Analog eLab Design Center (模拟电子实验室设计中心) [免费下载](#)。虚拟仪器提供选择输入波形和探测电路节点、电压以及波形的功能，从而构建一个动态的快速入门工具。

注

这些文件需要安装 TINA 软件 (由 DesignSoft™ 提供) 或者 TINA-TI™ 软件。请下载 [TINA-TI™ 文件夹](#) 中的免费 TINA-TI™ 软件。

11.2 文档支持

11.2.1 相关文档

如需相关文档，请参阅：

- 德州仪器 (TI), [《电路板布局技巧》](#)
- 德州仪器 (TI), [《模拟工程师电路设计指导手册》](#)

11.3 接收文档更新通知

要接收文档更新通知，请导航至 TI.com.cn 上的器件产品文件夹。单击右上角的 [通知我](#) 进行注册，即可每周接收产品信息更改摘要。有关更改的详细信息，请查看任何已修订文档中包含的修订历史记录。

11.4 社区资源

The following links connect to TI community resources. Linked contents are provided "AS IS" by the respective contributors. They do not constitute TI specifications and do not necessarily reflect TI's views; see TI's [Terms of Use](#).

TI E2E™ Online Community *TI's Engineer-to-Engineer (E2E) Community*. Created to foster collaboration among engineers. At e2e.ti.com, you can ask questions, share knowledge, explore ideas and help solve problems with fellow engineers.

Design Support *TI's Design Support* Quickly find helpful E2E forums along with design support tools and contact information for technical support.

11.5 商标

TINA-TI, E2E are trademarks of Texas Instruments.
Bluetooth is a registered trademark of Bluetooth SIG, Inc.
TINA, DesignSoft are trademarks of DesignSoft, Inc.
All other trademarks are the property of their respective owners.

11.6 静电放电警告



ESD 可能会损坏该集成电路。德州仪器 (TI) 建议通过适当的预防措施处理所有集成电路。如果不遵守正确的处理措施和安装程序，可能会损坏集成电路。

ESD 的损坏小至导致微小的性能降级，大至整个器件故障。精密的集成电路可能更容易受到损坏，这是因为非常细微的参数更改都可能会导致器件与其发布的规格不相符。

11.7 Glossary

[SLYZ022](#) — *TI Glossary*.

This glossary lists and explains terms, acronyms, and definitions.

12 机械、封装和可订购信息

以下页面包含机械、封装和可订购信息。这些信息是指定器件的最新可用数据。数据如有变更，恕不另行通知，且不会对此文档进行修订。如需获取此数据表的浏览器版本，请查阅左侧的导航栏。

PACKAGING INFORMATION

Orderable Device	Status (1)	Package Type	Package Drawing	Pins	Package Qty	Eco Plan (2)	Lead finish/ Ball material (6)	MSL Peak Temp (3)	Op Temp (°C)	Device Marking (4/5)	Samples
OPA1671IDBVR	ACTIVE	SOT-23	DBV	5	3000	RoHS & Green	NIPDAU SN	Level-2-260C-1 YEAR	-40 to 125	1X6T	Samples
OPA1671IDBVT	ACTIVE	SOT-23	DBV	5	250	RoHS & Green	NIPDAU SN	Level-2-260C-1 YEAR	-40 to 125	1X6T	Samples
OPA1671IDCKR	ACTIVE	SC70	DCK	5	3000	RoHS & Green	NIPDAU	Level-2-260C-1 YEAR	-40 to 125	1D3	Samples
OPA1671IDCKT	ACTIVE	SC70	DCK	5	250	RoHS & Green	NIPDAU	Level-2-260C-1 YEAR	-40 to 125	1D3	Samples

(1) The marketing status values are defined as follows:

ACTIVE: Product device recommended for new designs.

LIFEBUY: TI has announced that the device will be discontinued, and a lifetime-buy period is in effect.

NRND: Not recommended for new designs. Device is in production to support existing customers, but TI does not recommend using this part in a new design.

PREVIEW: Device has been announced but is not in production. Samples may or may not be available.

OBSELETE: TI has discontinued the production of the device.

(2) **RoHS:** TI defines "RoHS" to mean semiconductor products that are compliant with the current EU RoHS requirements for all 10 RoHS substances, including the requirement that RoHS substance do not exceed 0.1% by weight in homogeneous materials. Where designed to be soldered at high temperatures, "RoHS" products are suitable for use in specified lead-free processes. TI may reference these types of products as "Pb-Free".

RoHS Exempt: TI defines "RoHS Exempt" to mean products that contain lead but are compliant with EU RoHS pursuant to a specific EU RoHS exemption.

Green: TI defines "Green" to mean the content of Chlorine (Cl) and Bromine (Br) based flame retardants meet JS709B low halogen requirements of <=1000ppm threshold. Antimony trioxide based flame retardants must also meet the <=1000ppm threshold requirement.

(3) MSL, Peak Temp. - The Moisture Sensitivity Level rating according to the JEDEC industry standard classifications, and peak solder temperature.

(4) There may be additional marking, which relates to the logo, the lot trace code information, or the environmental category on the device.

(5) Multiple Device Markings will be inside parentheses. Only one Device Marking contained in parentheses and separated by a "-" will appear on a device. If a line is indented then it is a continuation of the previous line and the two combined represent the entire Device Marking for that device.

(6) Lead finish/Ball material - Orderable Devices may have multiple material finish options. Finish options are separated by a vertical ruled line. Lead finish/Ball material values may wrap to two lines if the finish value exceeds the maximum column width.

Important Information and Disclaimer:The information provided on this page represents TI's knowledge and belief as of the date that it is provided. TI bases its knowledge and belief on information provided by third parties, and makes no representation or warranty as to the accuracy of such information. Efforts are underway to better integrate information from third parties. TI has taken and

continues to take reasonable steps to provide representative and accurate information but may not have conducted destructive testing or chemical analysis on incoming materials and chemicals. TI and TI suppliers consider certain information to be proprietary, and thus CAS numbers and other limited information may not be available for release.

In no event shall TI's liability arising out of such information exceed the total purchase price of the TI part(s) at issue in this document sold by TI to Customer on an annual basis.

TAPE AND REEL INFORMATION

QUADRANT ASSIGNMENTS FOR PIN 1 ORIENTATION IN TAPE

*All dimensions are nominal

Device	Package Type	Package Drawing	Pins	SPQ	Reel Diameter (mm)	Reel Width W1 (mm)	A0 (mm)	B0 (mm)	K0 (mm)	P1 (mm)	W (mm)	Pin1 Quadrant
OPA1671IDBVR	SOT-23	DBV	5	3000	180.0	8.4	3.2	3.2	1.4	4.0	8.0	Q3
OPA1671IDBVT	SOT-23	DBV	5	250	180.0	8.4	3.2	3.2	1.4	4.0	8.0	Q3
OPA1671IDCKR	SC70	DCK	5	3000	178.0	9.0	2.4	2.5	1.2	4.0	8.0	Q3
OPA1671IDCKT	SC70	DCK	5	250	178.0	9.0	2.4	2.5	1.2	4.0	8.0	Q3

TAPE AND REEL BOX DIMENSIONS



*All dimensions are nominal

Device	Package Type	Package Drawing	Pins	SPQ	Length (mm)	Width (mm)	Height (mm)
OPA1671IDBVR	SOT-23	DBV	5	3000	210.0	185.0	35.0
OPA1671IDBVT	SOT-23	DBV	5	250	210.0	185.0	35.0
OPA1671IDCKR	SC70	DCK	5	3000	190.0	190.0	30.0
OPA1671IDCKT	SC70	DCK	5	250	190.0	190.0	30.0

DBV0005A



PACKAGE OUTLINE

SOT-23 - 1.45 mm max height

SMALL OUTLINE TRANSISTOR

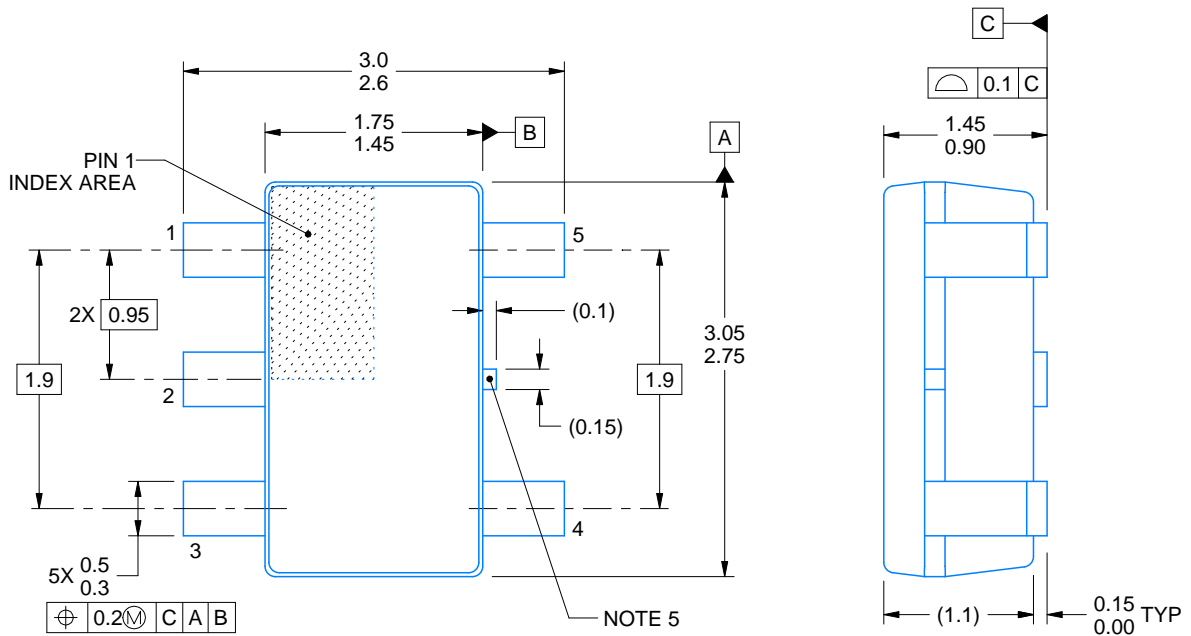

4214839/G 03/2023

NOTES:

1. All linear dimensions are in millimeters. Any dimensions in parenthesis are for reference only. Dimensioning and tolerancing per ASME Y14.5M.
2. This drawing is subject to change without notice.
3. Reference JEDEC MO-178.
4. Body dimensions do not include mold flash, protrusions, or gate burrs. Mold flash, protrusions, or gate burrs shall not exceed 0.25 mm per side.
5. Support pin may differ or may not be present.

EXAMPLE BOARD LAYOUT

DBV0005A

SOT-23 - 1.45 mm max height

SMALL OUTLINE TRANSISTOR



LAND PATTERN EXAMPLE
EXPOSED METAL SHOWN
SCALE:15X

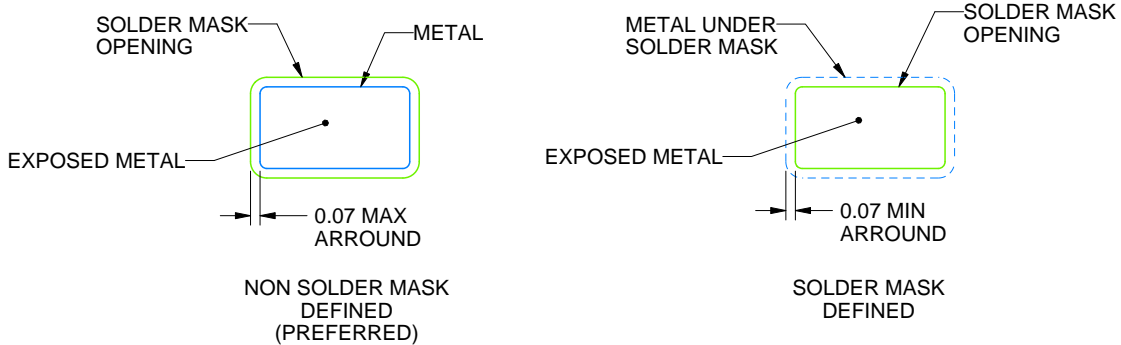

SOLDER MASK DETAILS

4214839/G 03/2023

NOTES: (continued)

6. Publication IPC-7351 may have alternate designs.

7. Solder mask tolerances between and around signal pads can vary based on board fabrication site.

EXAMPLE STENCIL DESIGN

DBV0005A

SOT-23 - 1.45 mm max height

SMALL OUTLINE TRANSISTOR



SOLDER PASTE EXAMPLE
BASED ON 0.125 mm THICK STENCIL
SCALE:15X

4214839/G 03/2023

NOTES: (continued)

8. Laser cutting apertures with trapezoidal walls and rounded corners may offer better paste release. IPC-7525 may have alternate design recommendations.
9. Board assembly site may have different recommendations for stencil design.

DCK0005A



PACKAGE OUTLINE

SOT - 1.1 max height

SMALL OUTLINE TRANSISTOR

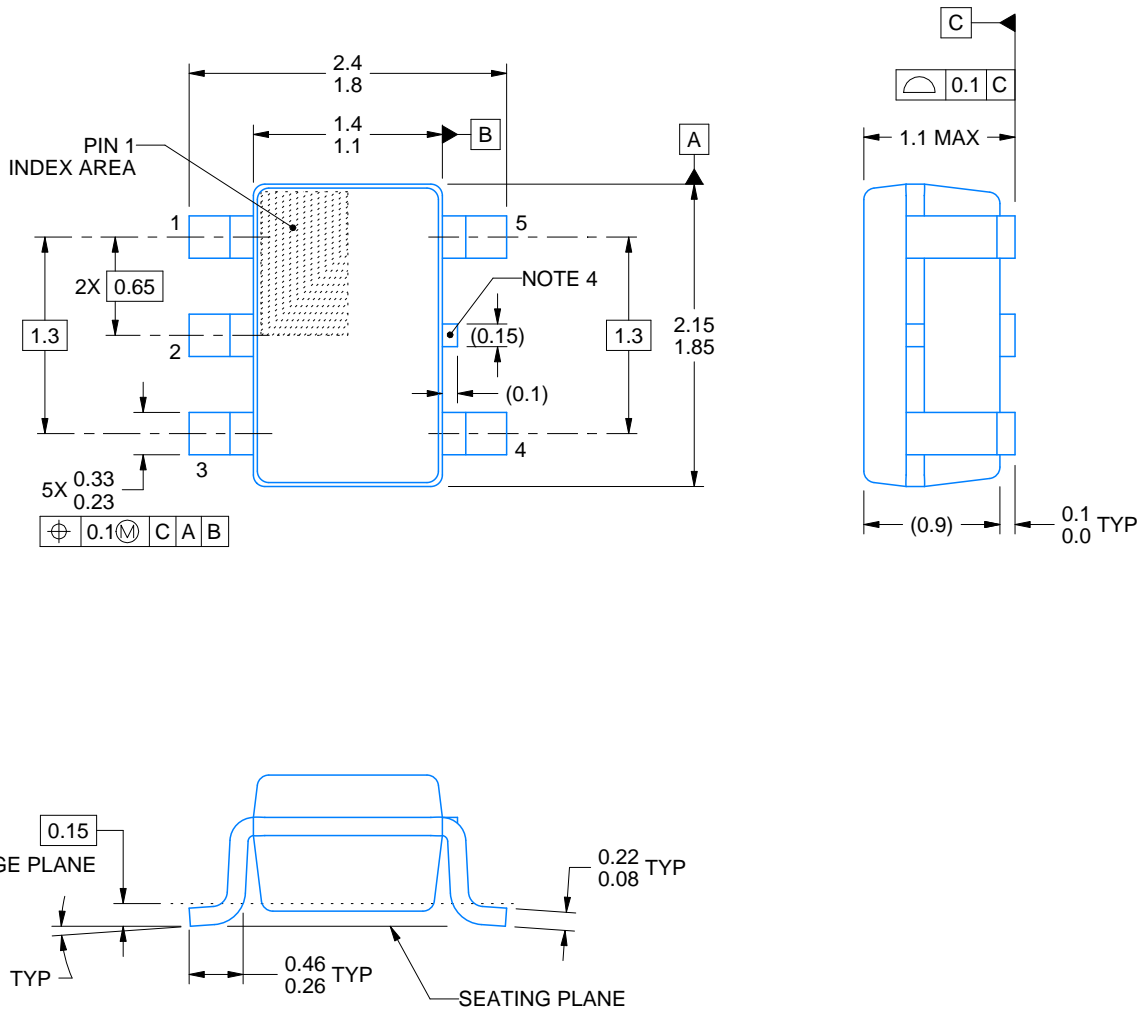

4214834/C 03/2023

NOTES:

1. All linear dimensions are in millimeters. Any dimensions in parenthesis are for reference only. Dimensioning and tolerancing per ASME Y14.5M.
2. This drawing is subject to change without notice.
3. Reference JEDEC MO-203.
4. Support pin may differ or may not be present.

EXAMPLE BOARD LAYOUT

DCK0005A

SOT - 1.1 max height

SMALL OUTLINE TRANSISTOR

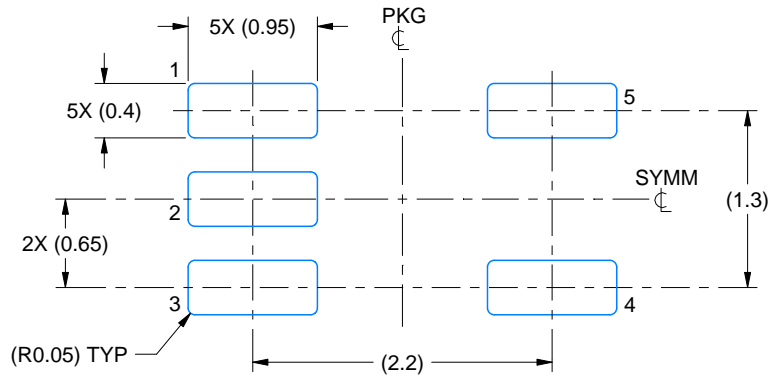

LAND PATTERN EXAMPLE
EXPOSED METAL SHOWN
SCALE:18X

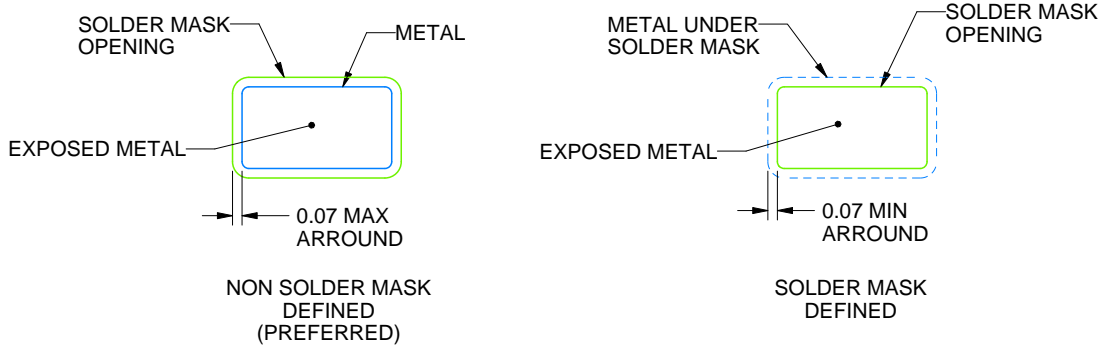

SOLDER MASK DETAILS

4214834/C 03/2023

NOTES: (continued)

- 4. Publication IPC-7351 may have alternate designs.
- 5. Solder mask tolerances between and around signal pads can vary based on board fabrication site.

EXAMPLE STENCIL DESIGN

DCK0005A

SOT - 1.1 max height

SMALL OUTLINE TRANSISTOR

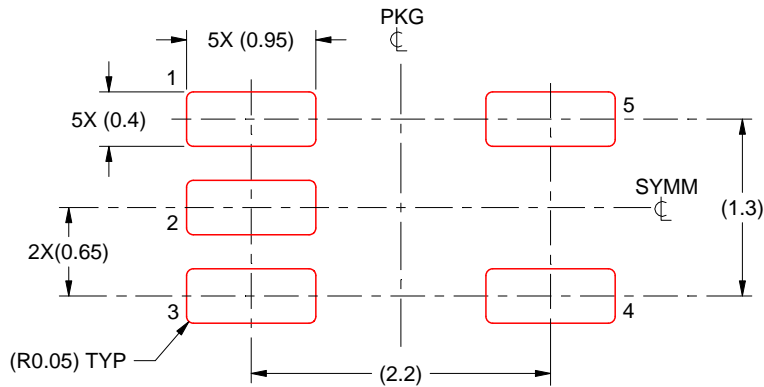

SOLDER PASTE EXAMPLE
BASED ON 0.125 THICK STENCIL
SCALE:18X

4214834/C 03/2023

NOTES: (continued)

6. Laser cutting apertures with trapezoidal walls and rounded corners may offer better paste release. IPC-7525 may have alternate design recommendations.
7. Board assembly site may have different recommendations for stencil design.

重要声明和免责声明

TI“按原样”提供技术和可靠性数据（包括数据表）、设计资源（包括参考设计）、应用或其他设计建议、网络工具、安全信息和其他资源，不保证没有瑕疵且不做任何明示或暗示的担保，包括但不限于对适销性、某特定用途方面的适用性或不侵犯任何第三方知识产权的暗示担保。

这些资源可供使用 TI 产品进行设计的熟练开发人员使用。您将自行承担以下全部责任：(1) 针对您的应用选择合适的 TI 产品，(2) 设计、验证并测试您的应用，(3) 确保您的应用满足相应标准以及任何其他功能安全、信息安全、监管或其他要求。

这些资源如有变更，恕不另行通知。TI 授权您仅可将这些资源用于研发本资源所述的 TI 产品的应用。严禁对这些资源进行其他复制或展示。您无权使用任何其他 TI 知识产权或任何第三方知识产权。您应全额赔偿因在这些资源的使用中对 TI 及其代表造成的任何索赔、损害、成本、损失和债务，TI 对此概不负责。

TI 提供的产品受 [TI 的销售条款](#) 或 [ti.com](#) 上其他适用条款/TI 产品随附的其他适用条款的约束。TI 提供这些资源并不会扩展或以其他方式更改 TI 针对 TI 产品发布的适用的担保或担保免责声明。

TI 反对并拒绝您可能提出的任何其他或不同的条款。

邮寄地址：Texas Instruments, Post Office Box 655303, Dallas, Texas 75265

Copyright © 2023，德州仪器 (TI) 公司