

## OPAx354 250MHz、轨至轨 I/O CMOS 运算放大器

### 1 特性

- 单位增益带宽：250MHz
- 高带宽：100MHz GBW
- 高压摆率：150V/ $\mu$ s
- 低噪声：6.5nV $\sqrt{\text{Hz}}$
- 轨至轨 I/O
- 高输出电流：> 100mA
- 出色的视频性能：
  - 差分增益：0.02%，差分相位：0.09°
  - 0.1dB 增益平坦度：40MHz
- 低输入偏置电流：3pA
- 静态电流：4.9mA
- 热关断
- 电源范围：2.5V 至 5.5V
- *MicroSIZE* 和 PowerPAD™ 封装

### 2 应用

- 视频处理
- 超声波
- 光网络、可调激光器
- 光电二极管跨阻放大器
- 有源滤波器
- 高速积分器
- 模数 (A/D) 转换器输入缓冲器
- 数模 (D/A) 转换器输出放大器
- 条形码扫描器
- 通信

### 3 说明

OPAx354 系列高速电压反馈 CMOS 运算放大器专为视频应用和其他需要宽带宽的应用而设计。这些器件单位增益稳定，可以输出大电流。差分增益为 0.02%，而差分相位为 0.09°。静态电流仅为每通道 4.9mA。

OPAx354 系列运算放大器针对低至 2.5V ( $\pm 1.25$ V) 和高达 5.5V ( $\pm 2.75$ V) 的单电源或双电源供电运行进行了优化。共模输入范围超出电源供电范围。电源轨的输出摆幅在 100mV 以内，从而支持宽动态范围。

对于需要 100mA 完全连续输出电流的应用，可使用单通道和双通道 8 引脚 HSOP PowerPAD 版本。

单通道版本 (OPA354) 采用微型 5 引脚 SOT-23 和 8 引脚 HSOP PowerPAD 封装。双通道版本 (OPA2354) 采用微型 8 引脚 VSSOP 和 8 引脚 HSOP PowerPAD 封装。四通道版本 (OPA4354) 采用 14 引脚 TSSOP 和 14 引脚 SOIC 封装。

多通道版本采用完全独立的电路，可将串扰降到最低并彻底消除相互干扰。全部功能的额定扩展工作温度范围为  $-40^{\circ}\text{C}$  至  $+125^{\circ}\text{C}$ 。

#### 器件信息<sup>(1)</sup>

器件型号	封装	封装尺寸 (标称值)
OPA354	HSOP (8)	4.89mm × 3.90mm
	SOT-23 (5)	2.90mm × 1.60mm
OPA2354	VSSOP (8)	3.00mm × 3.00mm
	HSOP (8)	4.89mm × 3.90mm
OPA4354	SOIC (14)	8.65mm × 3.91mm
	TSSOP (14)	5.00mm × 4.40mm

(1) 如需了解所有可用封装，请参阅数据表末尾的可订购产品附录。

#### 简化原理图

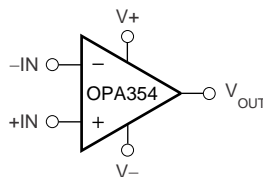

## 目录

1	特性 .....	1	8.4	Device Functional Modes .....	21
2	应用 .....	1	<b>9</b>	<b>Application and Implementation</b> .....	<b>22</b>
3	说明 .....	1	9.1	Application Information .....	22
4	修订历史记录 .....	2	9.2	Typical Application .....	22
5	<b>Device Comparison Table</b> .....	<b>3</b>	<b>10</b>	<b>Power Supply Recommendations</b> .....	<b>24</b>
6	<b>Pin Configuration and Functions</b> .....	<b>3</b>	<b>11</b>	<b>Layout</b> .....	<b>24</b>
7	<b>Specifications</b> .....	<b>6</b>	11.1	Layout Guidelines .....	24
7.1	Absolute Maximum Ratings .....	6	11.2	Layout Example .....	24
7.2	ESD Ratings .....	6	11.3	Power Dissipation .....	24
7.3	Recommended Operating Conditions .....	6	11.4	PowerPAD Thermally-Enhanced Package .....	25
7.4	Thermal Information: OPA354 .....	7	11.5	PowerPAD Assembly Process .....	25
7.5	Thermal Information: OPA2354 .....	7	<b>12</b>	<b>器件和文档支持</b> .....	<b>27</b>
7.6	Thermal Information: OPA4354 .....	7	12.1	文档支持 .....	27
7.7	Electrical Characteristics: $V_S = 2.7\text{ V to }5.5\text{ V (Single-Supply)}$ .....	8	12.2	相关链接 .....	27
7.8	Typical Characteristics .....	11	12.3	接收文档更新通知 .....	27
<b>8</b>	<b>Detailed Description</b> .....	<b>16</b>	12.4	社区资源 .....	27
8.1	Overview .....	16	12.5	商标 .....	27
8.2	Functional Block Diagram .....	16	12.6	静电放电警告 .....	27
8.3	Feature Description .....	17	12.7	术语表 .....	27
			<b>13</b>	<b>机械、封装和可订购信息</b> .....	<b>28</b>

## 4 修订历史记录

Changes from Revision F (June 2016) to Revision G	Page
• Deleted table note about input pins and input signals from <i>Absolute Maximum Ratings</i> table .....	6

Changes from Revision E (March 2002) to Revision F	Page
• 已添加 <i>ESD</i> 额定值表、特性说明部分、器件功能模式、应用和实施部分、电源建议部分、布局部分、器件和文档支持部分以及机械、封装和可订购信息部分 .....	1
• 已删除 <i>封装/订购信息</i> 表；请参阅数据表末尾的 <i>POA</i> .....	1
• Renamed <i>OPAx354 Related Products</i> table to <i>Device Comparison Table</i> .....	3

## 5 Device Comparison Table

FEATURES	PRODUCT
Shutdown Version of OPAx354 Family	OPAx357
200-MHz GBW, Rail-to-Rail Output, CMOS, Shutdown	OPAx355
200-MHz GBW, Rail-to-Rail Output, CMOS	OPAx356
38-MHz GBW, Rail-to-Rail Input/Output, CMOS	OPAx350/OPAx353
75-MHz BW G = 2, Rail-to-Rail Output	OPA2631
150-MHz BW G = 2, Rail-to-Rail Output	OPA2634
100-MHz BW, Differential Input/Output, 3.3-V Supply	THS412x

## 6 Pin Configuration and Functions

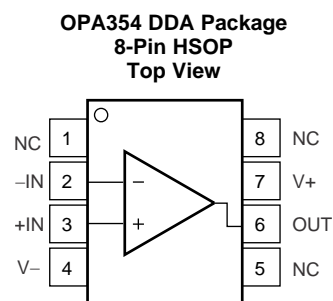
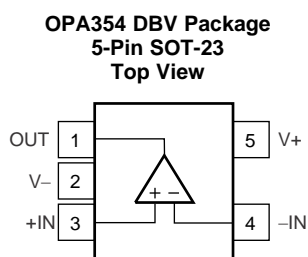

NC – no internal connection

PowerPAD must be connected to V- or left floating.

### Pin Functions: OPA354

NAME	PIN		I/O	DESCRIPTION
	SOT-23	HSOP		
-IN	4	2	I	Inverting input
+IN	3	3	I	Noninverting input
NC	—	1, 5, 8	—	No internal connection (can be left floating)
OUT	1	6	O	Output
V-	2	4	—	Negative (lowest) supply
V+	5	7	—	Positive (highest) supply

**OPA2354 DGK and DDA Packages  
8-Pin VSSOP, HSOP  
Top View**

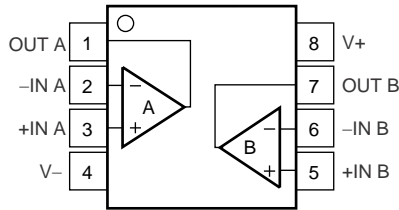

(1) PowerPAD must be connected to V- or left floating.

**Pin Functions: OPA2354**

PIN		I/O	DESCRIPTION
NAME	NO.		
-IN A	2	I	Inverting input, channel A
+IN A	3	I	Noninverting input, channel A
-IN B	6	I	Inverting input, channel B
+IN B	5	I	Noninverting input, channel B
OUT A	1	O	Output, channel A
OUT B	7	O	Output, channel B
V-	4	—	Negative (lowest) supply
V+	8	—	Positive (highest) supply

**OPA4354 D and PW Packages  
14-Pin SOIC, TSSOP  
Top View**

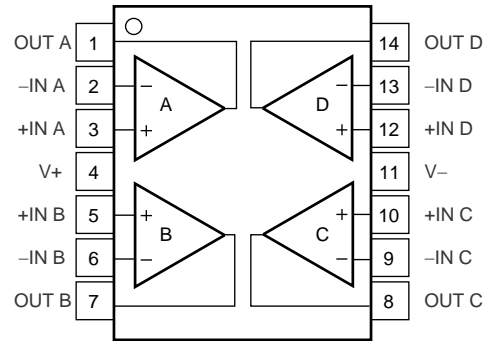

**Pin Functions: OPA4354**

PIN		I/O	DESCRIPTION
NAME	NO.		
-IN A	2	I	Inverting input, channel A
+IN A	3	I	Noninverting input, channel A
-IN B	6	I	Inverting input, channel B
+IN B	5	I	Noninverting input, channel B
-IN C	9	I	Inverting input, channel C
+IN C	10	I	Noninverting input, channel C
-IN D	13	I	Inverting input, channel D
+IN D	12	I	Noninverting input, channel D
OUT A	1	O	Output, channel A
OUT B	7	O	Output, channel B
OUT C	8	O	Output, channel C
OUT D	14	O	Output, channel D
V-	11	—	Negative (lowest) supply
V+	4	—	Positive (highest) supply

## 7 Specifications

### 7.1 Absolute Maximum Ratings

over operating free-air temperature range (unless otherwise noted)<sup>(1)</sup>

		MIN	MAX	UNIT
Voltage	Supply voltage, V+ to V-	7.5		V
	Signal input terminals	(V-) - (0.5)	(V+) + 0.5	
Current	Signal input terminals	-10	10	mA
	Output short circuit <sup>(2)</sup>	Continuous		
Temperature	Operating, T <sub>A</sub>	-55	150	°C
	Junction, T <sub>J</sub>	150		
	Storage, T <sub>stg</sub>	-65	150	

(1) Stresses beyond those listed under *Absolute Maximum Ratings* may cause permanent damage to the device. These are stress ratings only, which do not imply functional operation of the device at these or any other conditions beyond those indicated under *Recommended Operating Conditions*. Exposure to absolute-maximum-rated conditions for extended periods may affect device reliability.

(2) Short-circuit to ground, one amplifier per package.

### 7.2 ESD Ratings

		VALUE	UNIT
V <sub>(ESD)</sub> Electrostatic discharge	Human-body model (HBM), per ANSI/ESDA/JEDEC JS-001 <sup>(1)</sup>	±2000	V
	Charged-device model (CDM), per JEDEC specification JESD22-C101 <sup>(2)</sup>	±250	

(1) JEDEC document JEP155 states that 500-V HBM allows safe manufacturing with a standard ESD control process.

(2) JEDEC document JEP157 states that 250-V CDM allows safe manufacturing with a standard ESD control process.

### 7.3 Recommended Operating Conditions

over operating free-air temperature range (unless otherwise noted)

		MIN	MAX	UNIT
V <sub>S</sub>	Supply voltage, V- to V+	2.5	5.5	V
	Specified temperature	-40	125	°C

## 7.4 Thermal Information: OPA354

THERMAL METRIC <sup>(1)</sup>		OPA354		UNIT
		DBV (SOT-23)	DDA (HSOP)	
		5 PINS	8 PINS	
$R_{\theta JA}$	Junction-to-ambient thermal resistance	216.3	42.5	°C/W
$R_{\theta JC(top)}$	Junction-to-case (top) thermal resistance	84.3	54	°C/W
$R_{\theta JB}$	Junction-to-board thermal resistance	43.1	26.5	°C/W
$\Psi_{JT}$	Junction-to-top characterization parameter	3.8	8	°C/W
$\Psi_{JB}$	Junction-to-board characterization parameter	42.3	26.4	°C/W
$R_{\theta JC(bot)}$	Junction-to-case (bottom) thermal resistance	—	3.6	°C/W

(1) For more information about traditional and new thermal metrics, see the [Semiconductor and IC Package Thermal Metrics](#) application report.

## 7.5 Thermal Information: OPA2354

THERMAL METRIC <sup>(1)</sup>		OPA2354		UNIT
		DDA (HSOP)	DGK (VSSOP)	
		8 PINS	8 PINS	
$R_{\theta JA}$	Junction-to-ambient thermal resistance	40.6	175.9	°C/W
$R_{\theta JC(top)}$	Junction-to-case (top) thermal resistance	46	67.8	°C/W
$R_{\theta JB}$	Junction-to-board thermal resistance	20.7	97.1	°C/W
$\Psi_{JT}$	Junction-to-top characterization parameter	5.6	9.3	°C/W
$\Psi_{JB}$	Junction-to-board characterization parameter	20.6	95.5	°C/W
$R_{\theta JC(bot)}$	Junction-to-case (bottom) thermal resistance	2.5	—	°C/W

(1) For more information about traditional and new thermal metrics, see the [Semiconductor and IC Package Thermal Metrics](#) application report.

## 7.6 Thermal Information: OPA4354

THERMAL METRIC <sup>(1)</sup>		OPA4354		UNIT
		D (SOIC)	PW (TSSOP)	
		14 PINS	14 PINS	
$R_{\theta JA}$	Junction-to-ambient thermal resistance	83.8	92.6	°C/W
$R_{\theta JC(top)}$	Junction-to-case (top) thermal resistance	70.7	27.5	°C/W
$R_{\theta JB}$	Junction-to-board thermal resistance	59.5	33.6	°C/W
$\Psi_{JT}$	Junction-to-top characterization parameter	11.6	1.9	°C/W
$\Psi_{JB}$	Junction-to-board characterization parameter	37.7	33.1	°C/W
$R_{\theta JC(bot)}$	Junction-to-case (bottom) thermal resistance	—	—	°C/W

(1) For more information about traditional and new thermal metrics, see the [Semiconductor and IC Package Thermal Metrics](#) application report.

## 7.7 Electrical Characteristics: $V_S = 2.7\text{ V to }5.5\text{ V}$ (Single-Supply)

 at  $T_A = 25^\circ\text{C}$ ,  $R_F = 0\ \Omega$ ,  $R_L = 1\ \text{k}\Omega$ , and connected to  $V_S / 2$ , (unless otherwise noted)

PARAMETER		TEST CONDITIONS	MIN	TYP	MAX	UNIT
<b>OFFSET VOLTAGE</b>						
$V_{OS}$	Input offset voltage	$V_S = 5\text{ V}$ $T_A = 25^\circ\text{C}$		$\pm 2$	$\pm 8$	mV
		$V_S = 5\text{ V}$ , $T_A = -40^\circ\text{C to }+125^\circ\text{C}$			$\pm 10$	
$dV_{OS}/dT$	Input offset voltage vs temperature	$V_S = 5\text{ V}$ $T_A = -40^\circ\text{C to }+125^\circ\text{C}$		$\pm 4$		$\mu\text{V}/^\circ\text{C}$
PSRR	Input offset voltage vs power supply	$V_S = 2.7\text{ V to }5.5\text{ V}$ $V_{CM} = (V_S / 2) - 0.55\text{ V}$		$\pm 200$	$\pm 800$	$\mu\text{V/V}$
		$V_S = 2.7\text{ V to }5.5\text{ V}$ $V_{CM} = (V_S / 2) - 0.55\text{ V}$ at $T_A = -40^\circ\text{C to }+125^\circ\text{C}$			$\pm 900$	
<b>INPUT BIAS CURRENT</b>						
$I_B$	Input bias current			3	$\pm 50$	pA
$I_{OS}$	Input offset current			$\pm 1$	$\pm 50$	pA
<b>NOISE</b>						
$e_n$	Input voltage noise density	$f = 1\text{ MHz}$		6.5		$\text{nV}/\sqrt{\text{Hz}}$
$i_n$	Current noise density	$f = 1\text{ MHz}$		50		$\text{fA}/\sqrt{\text{Hz}}$
<b>INPUT VOLTAGE RANGE</b>						
$V_{CM}$	Common-mode voltage		$(V^-) - 0.1$		$(V^+) + 0.1$	V
CMRR	Common-mode rejection ratio	$V_S = 5.5\text{ V}$ $-0.1\text{ V} < V_{CM} < 3.5\text{ V}$ $T_A = 25^\circ\text{C}$	66	80		dB
		$V_S = 5.5\text{ V}$ $-0.1\text{ V} < V_{CM} < 3.5\text{ V}$ $T_A = -40^\circ\text{C to }+125^\circ\text{C}$	64			
		$V_S = 5.5\text{ V}$ $-0.1\text{ V} < V_{CM} < 5.6\text{ V}$ $T_A = 25^\circ\text{C}$	56	68		
		$V_S = 5.5\text{ V}$ $-0.1\text{ V} < V_{CM} < 5.6\text{ V}$ $T_A = -40^\circ\text{C to }+125^\circ\text{C}$	55			
<b>INPUT IMPEDANCE</b>						
	Differential			$10^{13} \parallel 2$		$\Omega \parallel \text{pF}$
	Common-mode			$10^{13} \parallel 2$		$\Omega \parallel \text{pF}$
<b>OPEN-LOOP GAIN</b>						
$A_{OL}$	Open-loop gain	$V_S = 5.5\text{ V}$ $0.3\text{ V} < V_O < 4.7\text{ V}$ $T_A = 25^\circ\text{C}$	94	110		dB
		$V_S = 5\text{ V}$ $0.4\text{ V} < V_O < 4.6\text{ V}$ $T_A = -40^\circ\text{C to }+125^\circ\text{C}$	90			
<b>FREQUENCY RESPONSE</b>						
$f_{-3\text{dB}}$	Small-signal bandwidth	At $G = +1$ $V_O = 100\text{ mV}_{PP}$ $R_F = 25\ \Omega$		250		MHz
		At $G = +2$ $V_O = 100\text{ mV}_{PP}$		90		
GBW	Gain-bandwidth product	$G = +10$		100		MHz
$f_{0.1\text{dB}}$	Bandwidth for 0.1-dB gain flatness	At $G = +2$ $V_O = 100\text{ mV}_{PP}$		40		MHz



**Electrical Characteristics:  $V_S = 2.7\text{ V to }5.5\text{ V}$  (Single-Supply) (continued)**

 at  $T_A = 25^\circ\text{C}$ ,  $R_F = 0\ \Omega$ ,  $R_L = 1\ \text{k}\Omega$ , and connected to  $V_S / 2$ , (unless otherwise noted)

PARAMETER		TEST CONDITIONS	MIN	TYP	MAX	UNIT
SR	Slew rate	$V_S = 5\text{ V}$ , $G = +1$ , 4-V step		150		V/ $\mu\text{s}$
		$V_S = 5\text{ V}$ , $G = +1$ , 2-V step		130		
		$V_S = 3\text{ V}$ , $G = +1$ , 2-V step		110		
	Rise-and-fall time	At $G = +1$ $V_O = 200\text{ mV}_{PP}$ 10% to 90%		2		ns
		At $G = +1$ , $V_O = 2\text{ V}_{PP}$ , 10% to 90%		11		
	Settling time	0.1%, $V_S = 5\text{ V}$ , $G = +1$ 2-V output step		30		ns
		0.01%, $V_S = 5\text{ V}$ , $G = +1$ 2-V output step		60		
	Overload recovery time	$V_{IN} \times \text{Gain} = V_S$		5		ns

**Electrical Characteristics:  $V_S = 2.7\text{ V to }5.5\text{ V}$  (Single-Supply) (continued)**

 at  $T_A = 25^\circ\text{C}$ ,  $R_F = 0\ \Omega$ ,  $R_L = 1\ \text{k}\Omega$ , and connected to  $V_S / 2$ , (unless otherwise noted)

PARAMETER		TEST CONDITIONS	MIN	TYP	MAX	UNIT
<b>FREQUENCY RESPONSE (CONTINUED)</b>						
Harmonic distortion	Second harmonic	At $G = +1$ , $f = 1\ \text{MHz}$ , $V_O = 2\ V_{PP}$ $R_L = 200\ \Omega$ , $V_{CM} = 1.5\ \text{V}$		-75		dBc
	Third harmonic	At $G = +1$ , $f = 1\ \text{MHz}$ $V_O = 2\ V_{PP}$ $R_L = 200\ \Omega$ , $V_{CM} = 1.5\ \text{V}$		-83		
Differential gain error		NTSC, $R_L = 150\ \Omega$		0.02%		
Differential phase error		NTSC, $R_L = 150\ \Omega$		0.09		°
Channel-to-channel crosstalk	OPA2354	$f = 5\ \text{MHz}$		-100		dB
	OPA4354			-84		
<b>OUTPUT</b>						
Voltage output swing from rail		$V_S = 5\ \text{V}$ , $R_L = 1\ \text{k}\Omega$ , $A_{OL} > 94\ \text{dB}$ $T_A = 25^\circ\text{C}$		0.1	0.3	V
		$V_S = 5\ \text{V}$ , $R_L = 1\ \text{k}\Omega$ , $A_{OL} > 90\ \text{dB}$ $T_A = -40^\circ\text{C to }+125^\circ\text{C}$			0.4	
$I_O$	Output current, single, dual, quad <sup>(1)(2)</sup>	$V_S = 5\ \text{V}$	100			mA
		$V_S = 3\ \text{V}$		50		mA
Closed-loop output impedance		$f < 100\ \text{kHz}$		0.05		$\Omega$
$R_O$	Open-loop output resistance			35		$\Omega$
<b>POWER SUPPLY</b>						
$V_S$	Specified voltage		2.7		5	V
	Operating voltage		2.5		5.5	
$I_Q$	Quiescent current (per amplifier)	$T_A = 25^\circ\text{C}$ , $V_S = 5\ \text{V}$ (enabled) $I_O = 0$		4.9	6	mA
		$T_A = -40^\circ\text{C to }+125^\circ\text{C}$			7.5	
<b>THERMAL SHUTDOWN: JUNCTION TEMPERATURE</b>						
Shutdown				160		°C
Reset from shutdown				140		°C
<b>THERMAL RANGE</b>						
Specified				-40	125	°C
Operating				-55	150	°C
Storage				-65	150	°C

 (1) See typical characteristic curves, *Output Voltage Swing vs Output Current* (图 20 and 图 22).

(2) Specified by design.

## 7.8 Typical Characteristics

at  $T_A = 25^\circ\text{C}$ ,  $V_S = 5\text{ V}$ ,  $G = +1$ ,  $R_F = 0\ \Omega$ ,  $R_L = 1\ \text{k}\Omega$ , and connected to  $V_S / 2$ , (unless otherwise noted)



图 1. Noninverting Small-Signal Frequency Response



图 2. Inverting Small-Signal Frequency Response

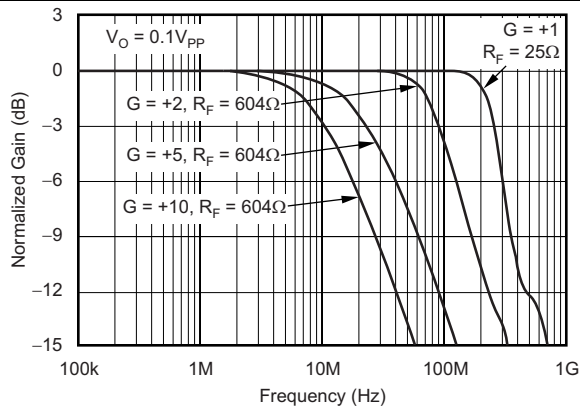

图 3. Noninverting Small-Signal Step Response

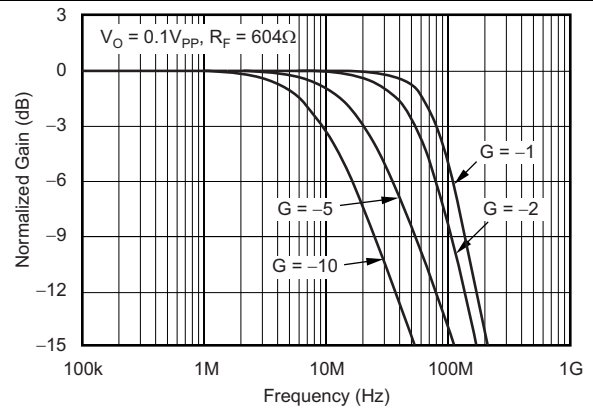

图 4. Noninverting Large-Signal Step Response

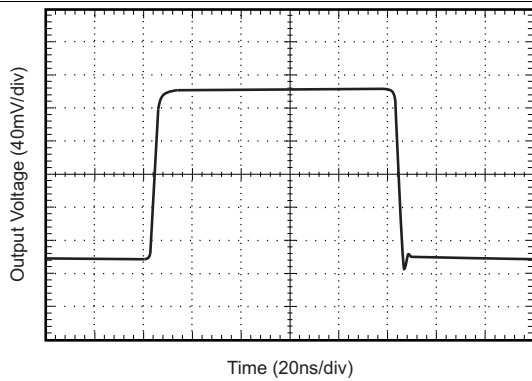

图 5. 0.1-dB Gain Flatness

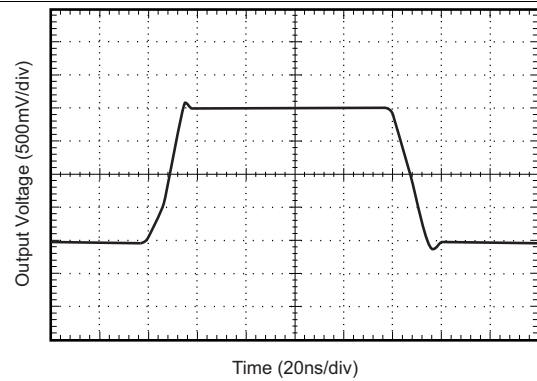

图 6. Harmonic Distortion vs Output Voltage

Typical Characteristics (接下页)

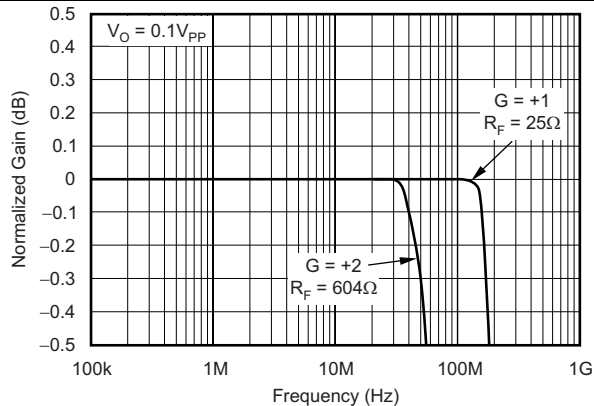
at  $T_A = 25^\circ\text{C}$ ,  $V_S = 5\text{ V}$ ,  $G = +1$ ,  $R_F = 0\ \Omega$ ,  $R_L = 1\ \text{k}\Omega$ , and connected to  $V_S / 2$ , (unless otherwise noted)

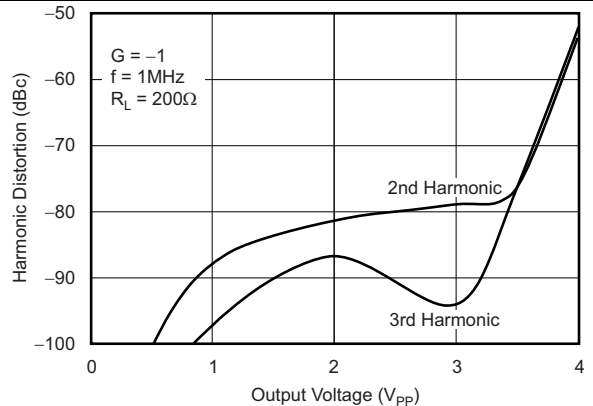
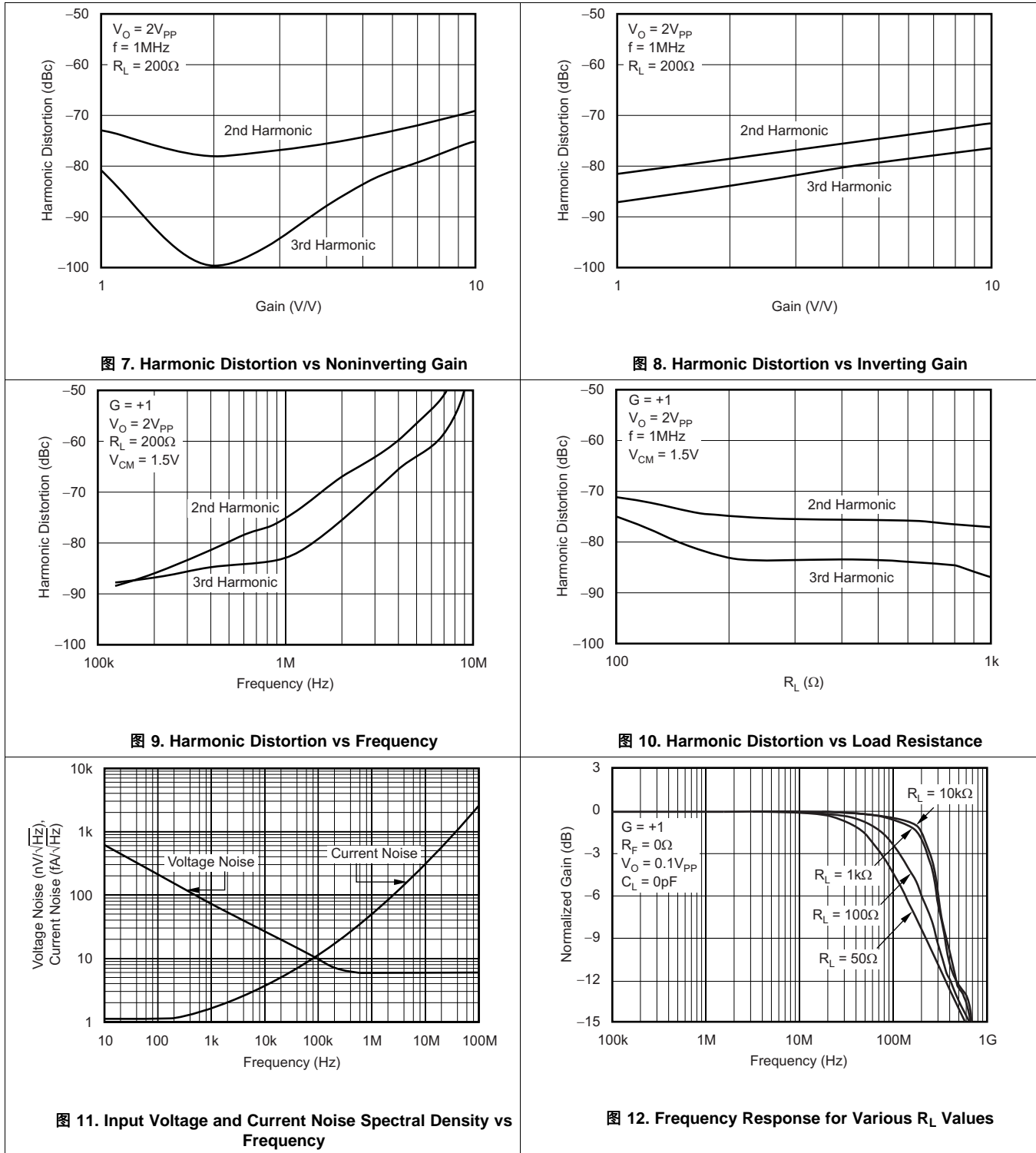

Typical Characteristics (接下页)

at  $T_A = 25^\circ\text{C}$ ,  $V_S = 5\text{ V}$ ,  $G = +1$ ,  $R_F = 0\ \Omega$ ,  $R_L = 1\ \text{k}\Omega$ , and connected to  $V_S / 2$ , (unless otherwise noted)



图 13. Frequency Response for Various  $C_L$  Values



图 14. Recommended  $R_S$  vs Capacitive Load

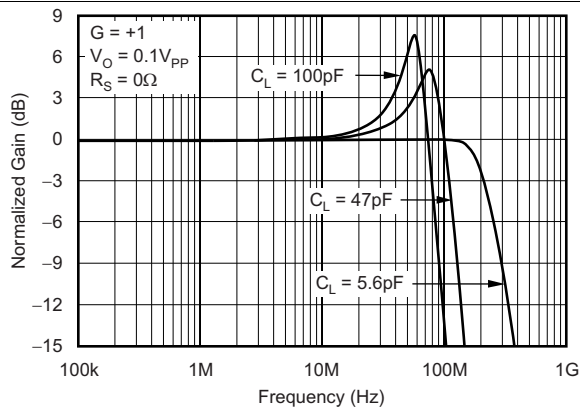

图 15. Frequency Response vs Capacitive Load

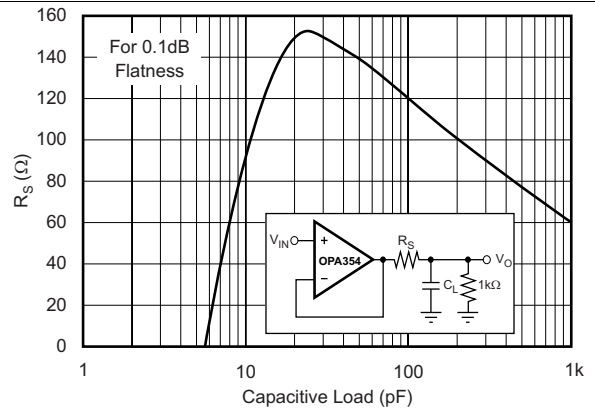

图 16. Common-Mode Rejection Ratio and Power-Supply Rejection Ratio vs Frequency

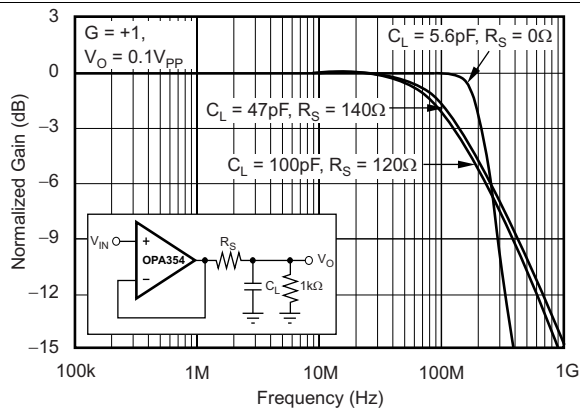

图 17. Open-Loop Gain and Phase

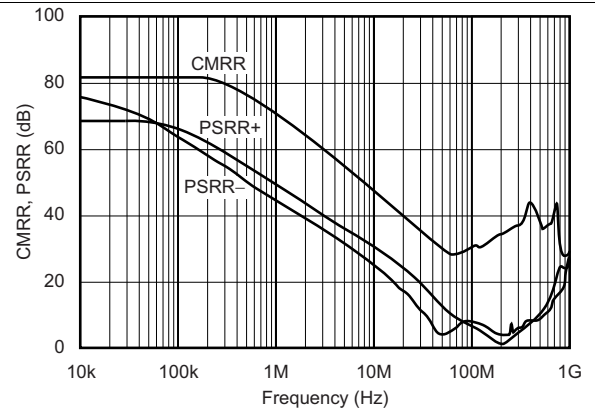

图 18. Composite Video Differential Gain and Phase

Typical Characteristics (接下页)

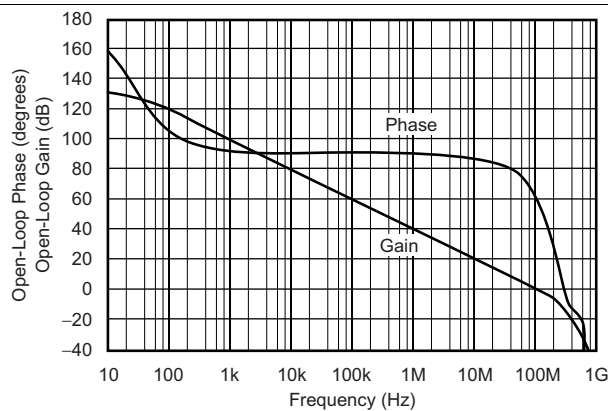
at  $T_A = 25^\circ\text{C}$ ,  $V_S = 5\text{ V}$ ,  $G = +1$ ,  $R_F = 0\ \Omega$ ,  $R_L = 1\ \text{k}\Omega$ , and connected to  $V_S / 2$ , (unless otherwise noted)

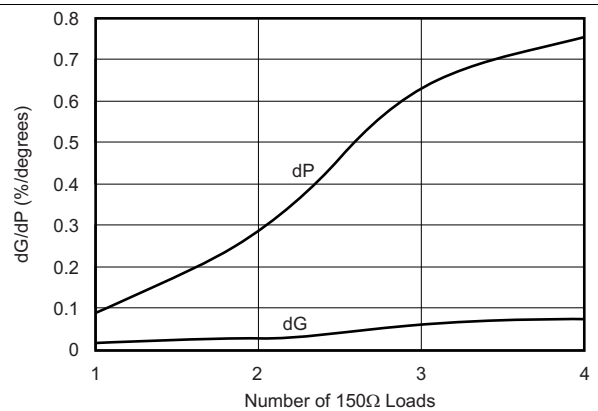
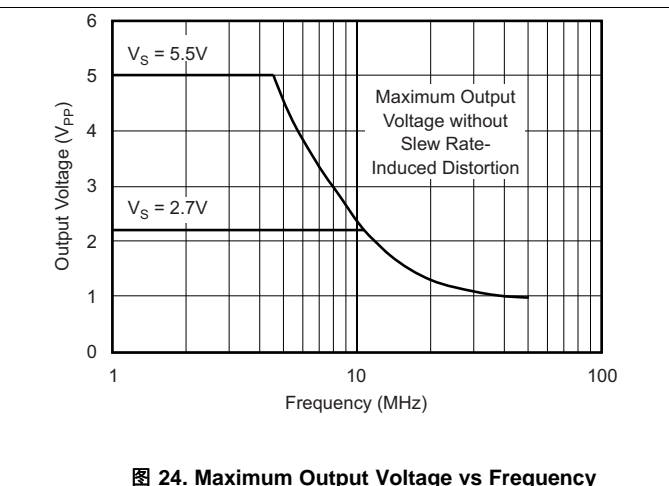
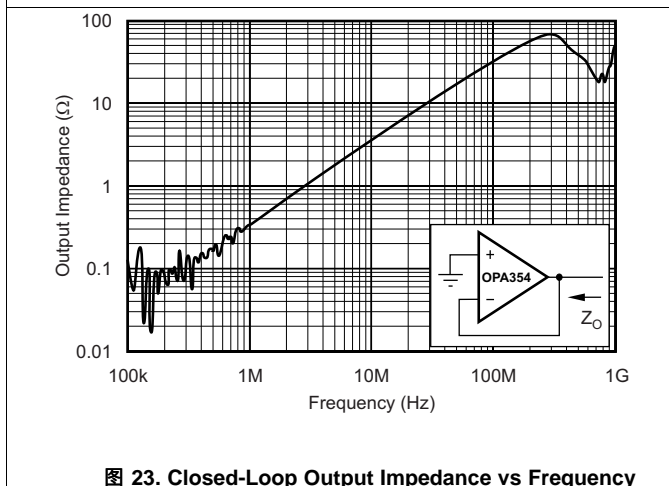
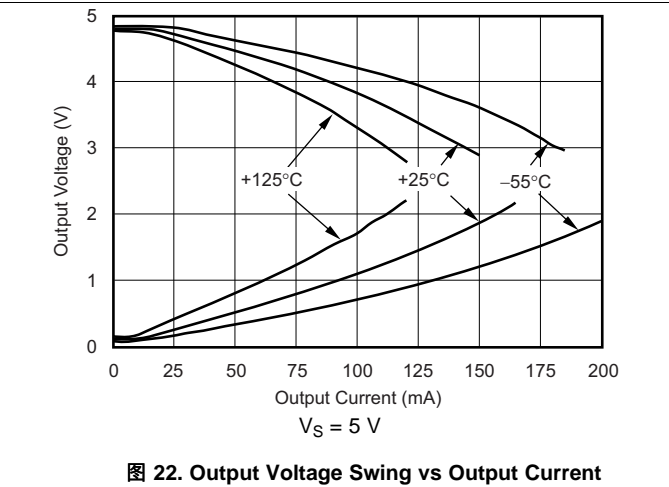
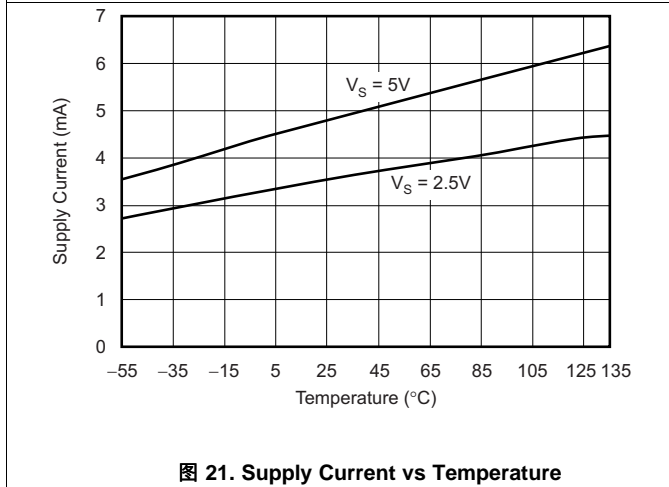
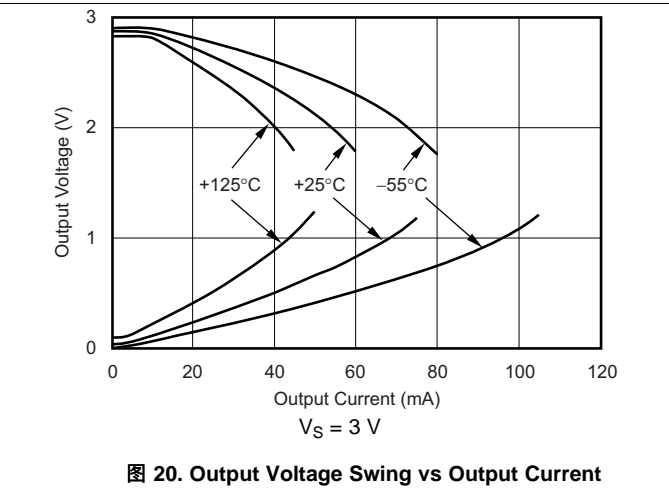
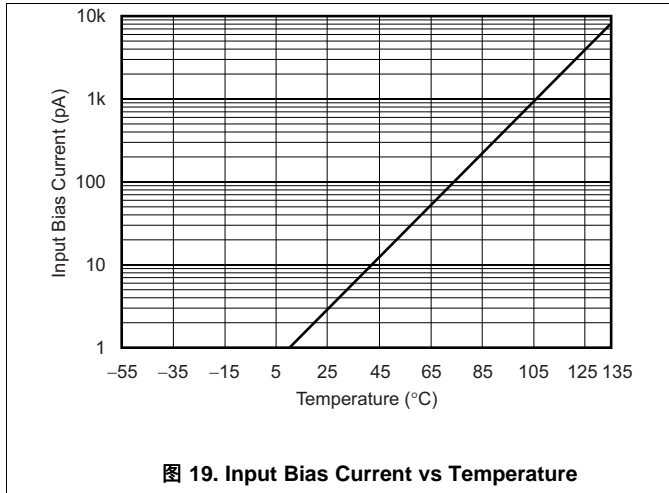

Typical Characteristics (接下页)

at  $T_A = 25^\circ\text{C}$ ,  $V_S = 5\text{ V}$ ,  $G = +1$ ,  $R_F = 0\ \Omega$ ,  $R_L = 1\ \text{k}\Omega$ , and connected to  $V_S / 2$ , (unless otherwise noted)



图 25. Output Settling Time to 0.1%



图 26. Open-Loop Gain vs Temperature

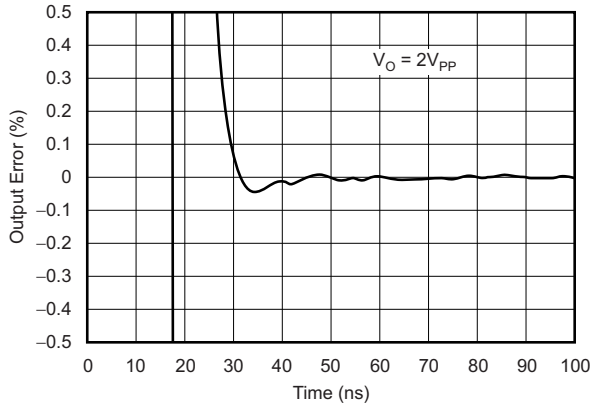

图 27. Offset Voltage Production Distribution

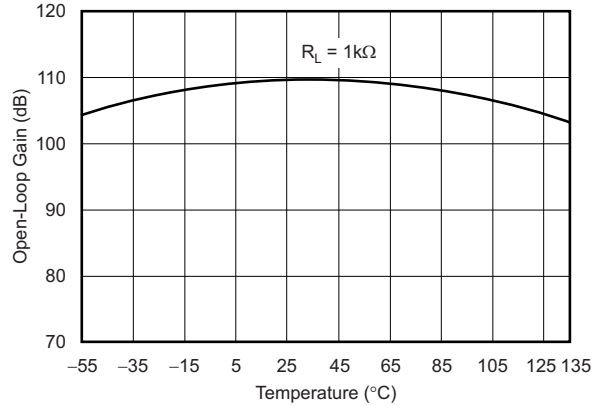

图 28. Common-Mode Rejection Ratio and Power-Supply Rejection Ratio vs Temperature

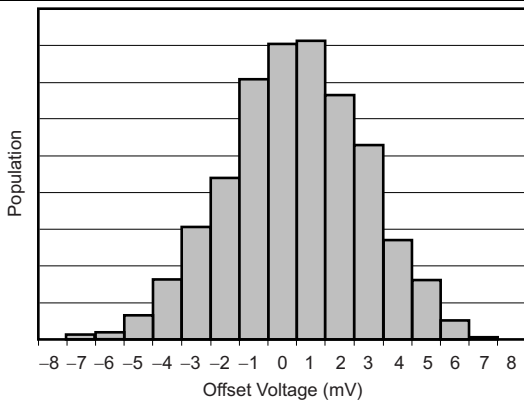

图 29. Channel-to-Channel Crosstalk

## 8 Detailed Description

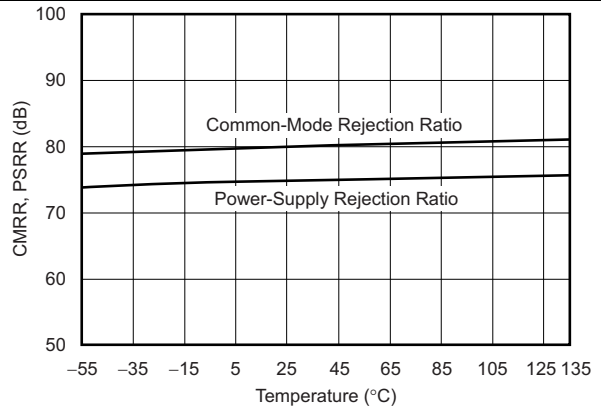
### 8.1 Overview

The OPAx354 is a CMOS, rail-to-rail I/O, high-speed, voltage-feedback operational amplifier designed for video, high-speed, and other applications. It is available as a single, dual, or quad op amp.

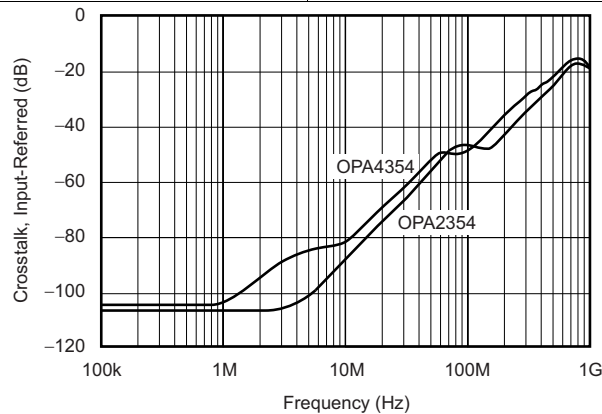
The amplifier features a 100-MHz gain bandwidth, and 150-V/ $\mu$ s slew rate, but the amplifier is unity-gain stable and can operate as a 1-V/V voltage follower.

### 8.2 Functional Block Diagram

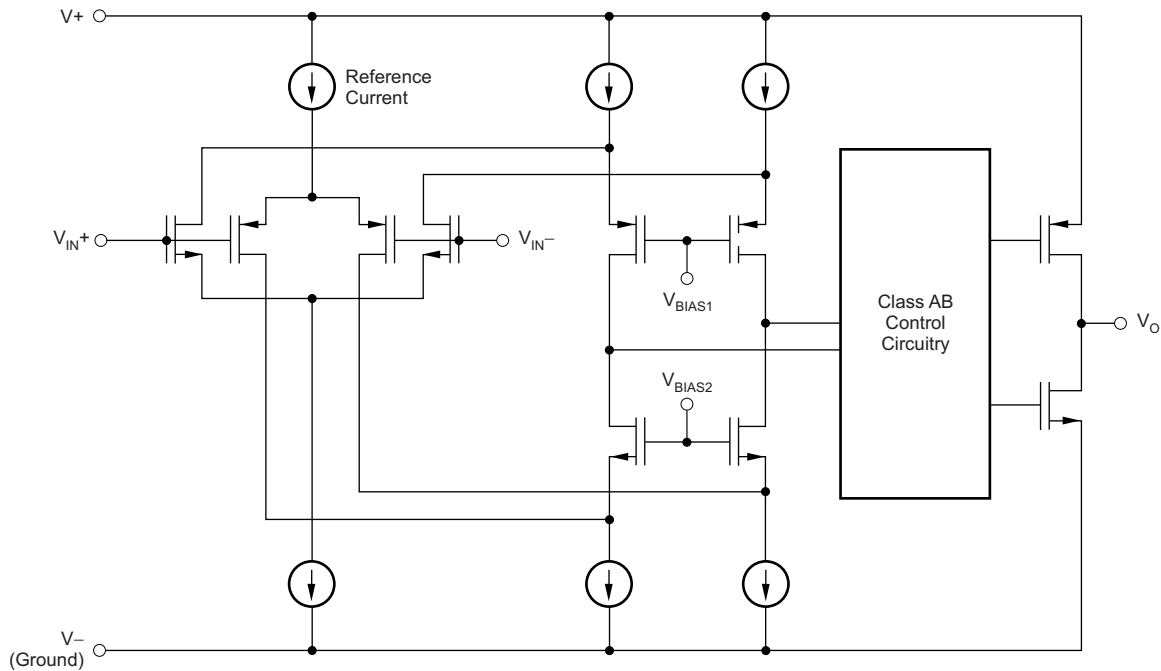



## 8.3 Feature Description

### 8.3.1 Operating Voltage

The OPAx354 is specified over a power-supply range of 2.7 V to 5.5 V ( $\pm 1.35$  V to  $\pm 2.75$  V). However, the supply voltage may range from 2.5 V to 5.5 V ( $\pm 1.25$  V to  $\pm 2.75$  V). Supply voltages higher than 7.5 V (absolute maximum) can permanently damage the amplifier.

Parameters that vary over supply voltage or temperature are shown in the *Typical Characteristics* section of this data sheet.

### 8.3.2 Rail-to-Rail Input

The specified input common-mode voltage range of the OPAx354 extends 100 mV beyond the supply rails. This extended range is achieved with a complementary input stage: an N-channel input differential pair in parallel with a P-channel differential pair, as shown in the *Functional Block Diagram*. The N-channel pair is active for input voltages close to the positive rail, typically  $(V+) - 1.2$  V to 100 mV above the positive supply, while the P-channel pair is on for inputs from 100 mV below the negative supply to approximately  $(V+) - 1.2$  V. There is a small transition region, typically  $(V+) - 1.5$  V to  $(V+) - 0.9$  V, in which both pairs are on. This 600-mV transition region vary  $\pm 500$  mV with process variation. Therefore, the transition region (both input stages on) range from  $(V+) - 2$  V to  $(V+) - 1.5$  V on the low end, up to  $(V+) - 0.9$  V to  $(V+) - 0.4$  V on the high end.

A double-folded cascode adds the signal from the two input pairs and presents a differential signal to the class AB output stage.

### 8.3.3 Rail-to-Rail Output

A class AB output stage with common-source transistors achieves rail-to-rail output. For high-impedance loads ( $> 200 \Omega$ ), the output voltage swing is typically 100 mV from the supply rails. With 10- $\Omega$  loads, a useful output swing is achieved while maintaining high open-loop gain. See the typical characteristic curves, *Output Voltage Swing vs Output Current* (图 20 and 图 22).

### 8.3.4 Output Drive

The OPAx354 output stage supplies a continuous output current of  $\pm 100$  mA and yet provide approximately 2.7 V of output swing on a 5-V supply, as shown in 图 30. For maximum reliability, TI does not recommend running a continuous DC current in excess of  $\pm 100$  mA. See the typical characteristic curves, *Output Voltage Swing vs Output Current* (图 20 and 图 22). For supplying continuous output currents greater than  $\pm 100$  mA, the OPAx354 may be operated in parallel, as shown in 图 31.



图 30. Laser Diode Driver

### Feature Description (接下页)

The OPAX354 provides peak currents up to 200 mA, which corresponds to the typical short-circuit current. Therefore, an on-chip thermal shutdown circuit is provided to protect the OPAX354 from dangerously high junction temperatures. At 160°C, the protection circuit shuts down the amplifier. Normal operation resumes when the junction temperature cools to below 140°C.

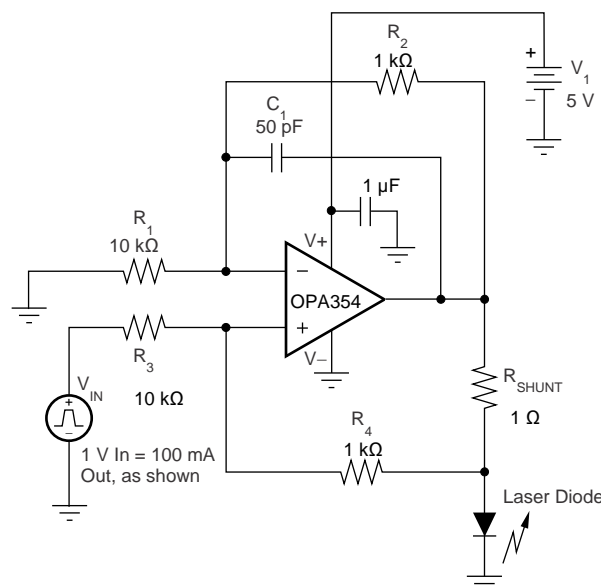

图 31. Parallel Operation

### 8.3.5 Video

The OPAX354 output stage is capable of driving standard back-terminated 75-Ω video cables, as shown in 图 32. By back-terminating a transmission line, the output stage does not exhibit a capacitive load to the driver. A properly back-terminated 75-Ω cable does not appear as capacitance; the cable presents a 150-Ω resistive load to the OPAX354 output.

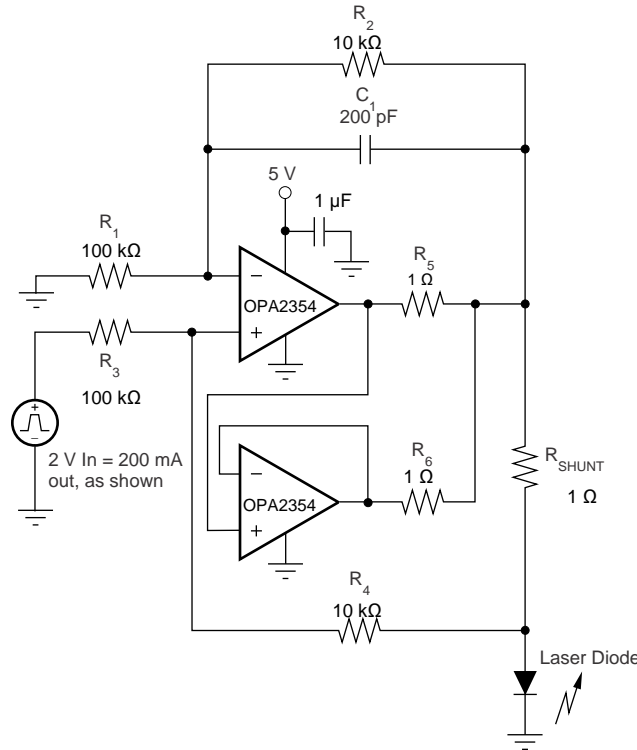

图 32. Single-Supply Video Line Driver

The OPAX354 is used as an amplifier for RGB graphic signals, which feature a voltage of zero at the video black level, by offsetting and AC-coupling the signal. See 图 33.

Feature Description (接下页)

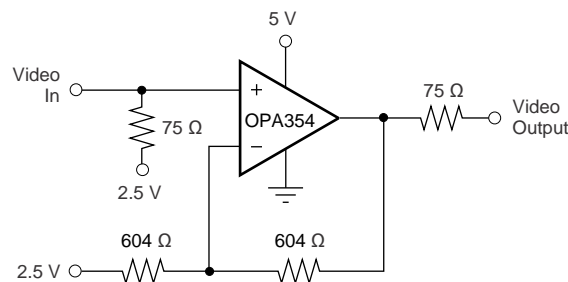
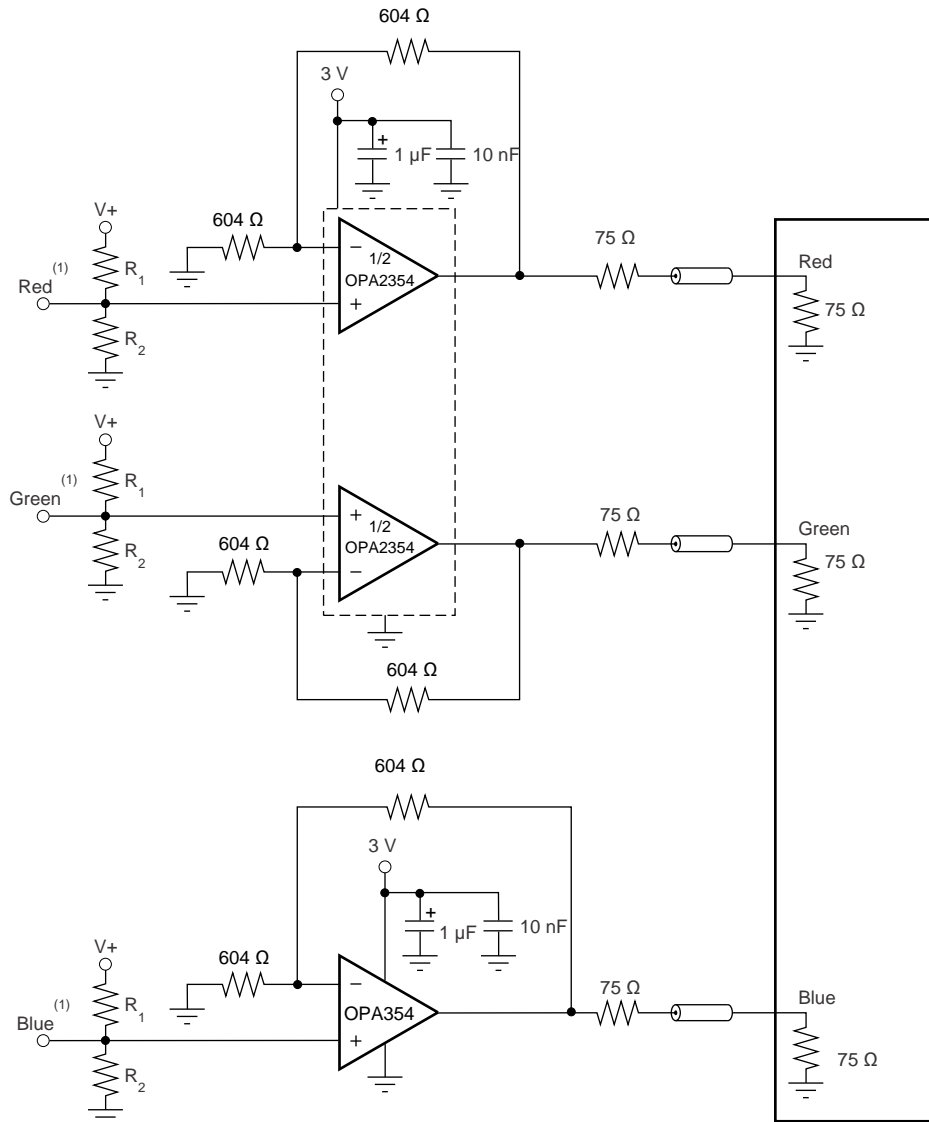

(1) Source video signal offset 300 mV above ground to accommodate op amp swing-to-ground capability.

图 33. RGB Cable Driver

## Feature Description (接下页)

### 8.3.6 Driving Analog-to-Digital converters

The OPAx354 series op amps offer 60 ns of settling time to 0.01%, making the series a good choice for driving high- and medium-speed sampling A/D converters and reference circuits. The OPAx354 series provide an effective means of buffering the A/D converter input capacitance and resulting charge injection while providing signal gain. For applications requiring high DC accuracy, the [OPA350 series](#) is recommended.

图 34 shows the OPAx354 driving an A/D converter. With the OPAx354 in an inverting configuration, a capacitor across the feedback resistor is used to filter high-frequency noise in the signal.

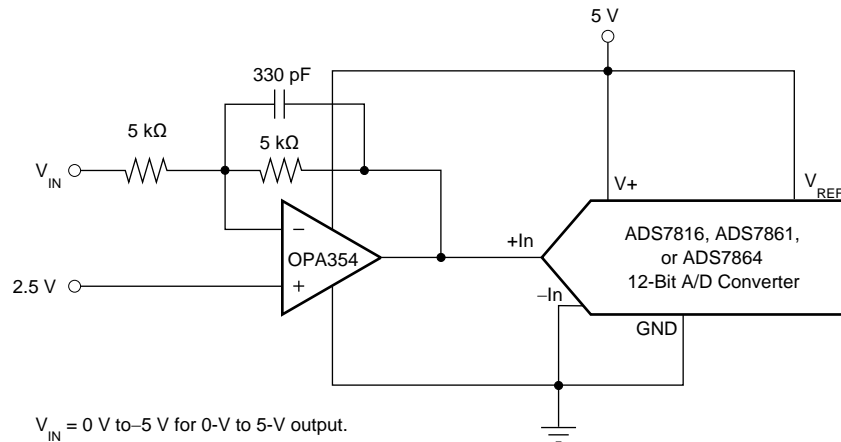

A/D converter input = 0 V to  $V_{REF}$

图 34. The OPAx354 in Inverting Configuration Driving the ADS7816

### 8.3.7 Capacitive Load and Stability

The OPAx354 series op amps drives a wide range of capacitive loads. However, all op amps may become unstable under certain conditions. Op amp configuration, gain, and load value are just a few of the factors to consider when determining stability. An op amp in unity-gain configuration is most susceptible to the effects of capacitive loading. The capacitive load reacts with the device output resistance, along with any additional load resistance, to create a pole in the small-signal response that degrades the phase margin. See the *Frequency Response for Various  $C_L$*  typical characteristic curve (图 13) for details.

The OPAx354 topology enhances its ability to drive capacitive loads. In unity gain, these op amps perform well with large capacitive loads. See the *Recommended  $R_S$  vs Capacitive Load* (图 14) and *Frequency Response vs Capacitive Load* (图 15) typical characteristic curves for details.

One method of improving capacitive load drive in the unity-gain configuration is to insert a 10- $\Omega$  to 20- $\Omega$  resistor in series with the output, as shown in 图 35. This configuration significantly reduces ringing with large capacitive loads; see the *Frequency Response vs Capacitive Load* typical characteristic curve (图 15). However, if there is a resistive load in parallel with the capacitive load,  $R_S$  creates a voltage divider. This voltage division introduces a DC error at the output and slightly reduces output swing. This error may be insignificant. For instance, with  $R_L = 10\text{ k}\Omega$  and  $R_S = 20\ \Omega$ , there is an error of approximately 0.2% at the output.



图 35. Series Resistor in Unity-Gain Configuration Improves Capacitive Load Drive

## Feature Description (接下页)

### 8.3.8 Wideband Transimpedance Amplifier

Wide bandwidth, low input bias current, low input voltage, and current noise make the OPAx354 a preferred wideband photodiode transimpedance amplifier for low-voltage single-supply applications. Low-voltage noise is important because photodiode capacitance causes the effective noise gain of the circuit to increase at high frequency.

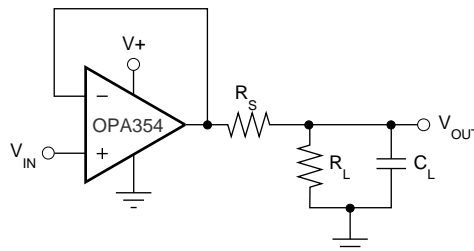
The key elements to a transimpedance design (as shown in 图 36) are the expected diode capacitance [including the parasitic input common-mode and differential-mode input capacitance (2 + 2) pF for the OPAx354], the desired transimpedance gain ( $R_F$ ), and the gain-bandwidth product (GBW) for the OPAx354 (100 MHz, typical). With these three variables set, the feedback capacitor value ( $C_F$ ) may be set to control the frequency response.



图 36. Transimpedance Amplifier

To achieve a maximally flat, second-order, Butterworth frequency response, the feedback pole must be set as shown in 公式 1:

$$\frac{1}{2\pi R_F C_F} = \sqrt{\frac{\text{GBP}}{4\pi R_F C_D}} \quad (1)$$

Typical surface-mount resistors have a parasitic capacitance of approximately 0.2 pF that must be deducted from the calculated feedback capacitance value. Bandwidth is calculated by 公式 2:

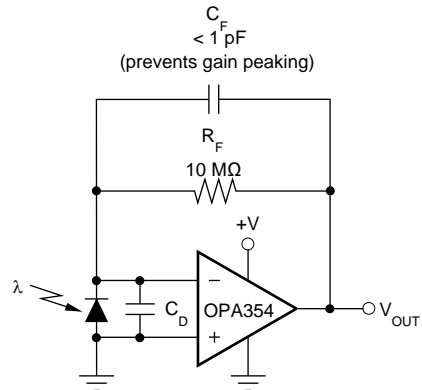
$$f_{-3\text{dB}} = \sqrt{\frac{\text{GBP}}{2\pi R_F C_D}} \text{ Hz} \quad (2)$$

For even higher transimpedance bandwidth, the high-speed CMOS OPA355 (200-MHz GBW) or the OPA655 (400-MHz GBW) may be used.

## 8.4 Device Functional Modes

The OPAx354 family of devices is powered on when the supply is connected. The devices can operate as single-supply operational amplifiers or dual-supply amplifiers depending on the application. The devices are used with asymmetrical supplies as long as the differential voltage ( $V_-$  to  $V_+$ ) is at least 1.8 V and no greater than 5.5 V (example:  $V_-$  set to -3.5 V and  $V_+$  set to 1.5 V).

## 9 Application and Implementation

### 注

Information in the following applications sections is not part of the TI component specification, and TI does not warrant its accuracy or completeness. TI's customers are responsible for determining suitability of components for their purposes. Customers should validate and test their design implementation to confirm system functionality.

### 9.1 Application Information

The OPAx354 family of devices is a CMOS, rail-to-rail I/O, high-speed, voltage-feedback operational amplifier designed for video, high-speed, and other applications. The OPAx354 family of devices is available as a single, dual, or quad op amp. The amplifier features a 100-MHz gain bandwidth, and 150-V/ $\mu$ s slew rate, but it is unity-gain stable and operates as a 1-V/V voltage follower.

### 9.2 Typical Application

Wide gain bandwidth, low input bias current, low input voltage, and current noise make the OPAx354 family of devices an ideal wideband photodiode transimpedance amplifier. Low-voltage noise is important because photodiode capacitance causes the effective noise gain of the circuit to increase at high frequency. The key elements to a transimpedance design, as shown in 图 37, are the expected diode capacitance, (which include the parasitic input common-mode and differential-mode input capacitance) the desired transimpedance gain, and the gain-bandwidth (GBW) for the OPAx354 family of devices (20 MHz). With these three variables set, the feedback capacitor value is set to control the frequency response. Feedback capacitance includes the stray capacitance, which is 0.2 pF for a typical surface-mount resistor.



图 37. Dual-Supply Transimpedance Amplifier

#### 9.2.1 Design Requirements

For this design example, use the parameters listed in 表 1 as the input parameters.

表 1. Design Parameters

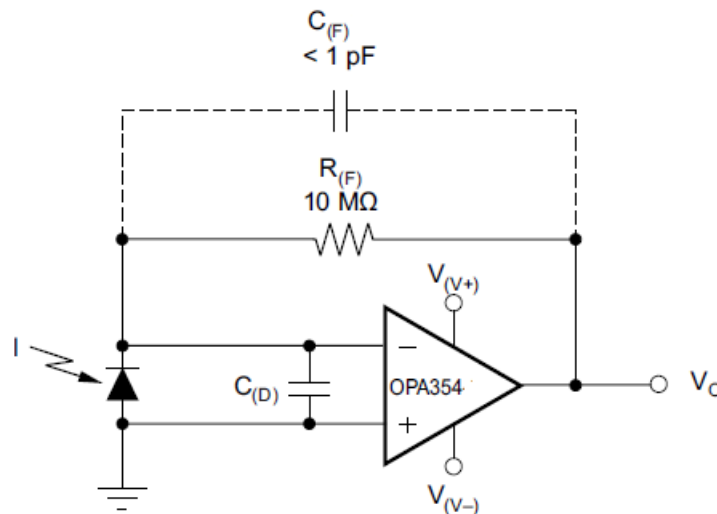
PARAMETER	EXAMPLE VALUE
Supply voltage, $V_{(V+)}$	2.5 V
Supply voltage, $V_{(V-)}$	-2.5 V

$C_{(F)}$  is optional to prevent gain peaking.  $C_{(F)}$  includes the stray capacitance of  $R_{(F)}$ .

### 9.2.2 Detailed Design Procedure

To achieve a maximally-flat, second-order Butterworth frequency response, set the feedback pole using [公式 3](#).

$$\frac{1}{2 \times \pi \times R_{(F)} \times C_{(F)}} = \sqrt{\frac{GBW}{4 \times \pi \times R_{(F)} \times C_{(D)}}} \tag{3}$$

Calculate the bandwidth using [公式 4](#).

$$f_{(-3 \text{ dB})} = \sqrt{\frac{GBW}{2 \times \pi \times R_{(F)} \times C_{(D)}}} \tag{4}$$

#### 9.2.2.1 Optimizing the Transimpedance Circuit

To achieve the best performance, components must be selected according to the following guidelines:

1. For lowest noise, select  $R_{(F)}$  to create the total required gain. Using a lower value for  $R_{(F)}$  and adding gain after the transimpedance amplifier generally produces poorer noise performance. The noise produced by  $R_{(F)}$  increases with the square-root of  $R_{(F)}$ , whereas the signal increases linearly. Therefore, signal-to-noise ratio improves when all the required gain is placed in the transimpedance stage.
2. Minimize photodiode capacitance and stray capacitance at the summing junction (inverting input). This capacitance causes the voltage noise of the op amp to amplify (increasing amplification at high frequency). Using a low-noise voltage source to reverse-bias a photodiode reduce the capacitance. Smaller photodiodes have lower capacitance. Use optics to concentrate light on a small photodiode.
3. Noise increases with increased bandwidth. Limit the circuit bandwidth to only the required bandwidth. Use a capacitor across the  $R_{(F)}$  to limit bandwidth, even if a capacitor not required for stability.
4. Circuit board leakage degrades the performance of an otherwise well-designed amplifier. Clean the circuit board carefully. A circuit board guard trace that encircles the summing junction and is driven at the same voltage helps control leakage.

### 9.2.3 Application Curve

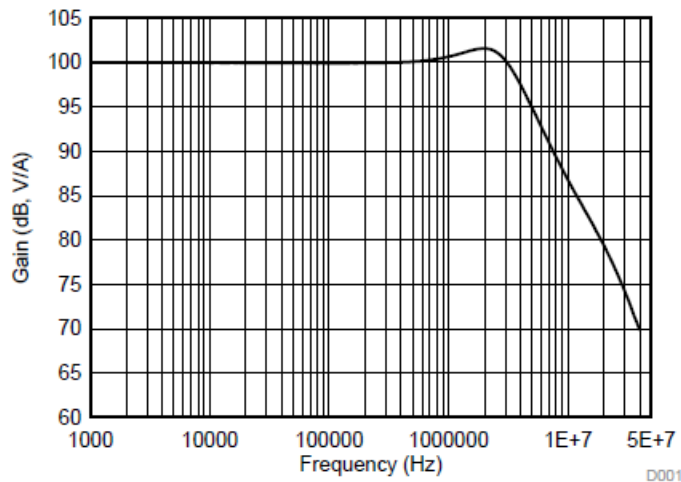

**图 38. AC Transfer Function**

## 10 Power Supply Recommendations

The OPAx354 family of devices is specified for operation from 2.5 V to 5.5 V ( $\pm 1.25$  to  $\pm 2.75$  V); many specifications apply from  $-40^{\circ}\text{C}$  to  $+125^{\circ}\text{C}$ . Parameters that exhibit significant variance with regard to operating voltage or temperature are shown [Typical Characteristics](#).

Place 0.1- $\mu\text{F}$  bypass capacitors close to the power-supply pins to reduce errors coupling in from noisy or high impedance power supplies. For more detailed information on bypass capacitor placement, see the [Layout Guidelines](#) section..

## 11 Layout

### 11.1 Layout Guidelines

Good high-frequency printed-circuit board (PCB) layout techniques must be employed for the OPAx354. Generous use of ground planes, short and direct signal traces, and a suitable bypass capacitor located at the V+ pin ensure clean, stable operation. Large areas of copper provides a means of dissipating heat that is generated in normal operation.

TI does not recommend using sockets with any high-speed amplifier.

A 10-nF ceramic bypass capacitor is the minimum recommended value; adding a 1- $\mu\text{F}$  or larger tantalum capacitor in parallel is beneficial when driving a low-resistance load. Providing adequate bypass capacitance is essential to achieving low harmonic and intermodulation distortion.

### 11.2 Layout Example

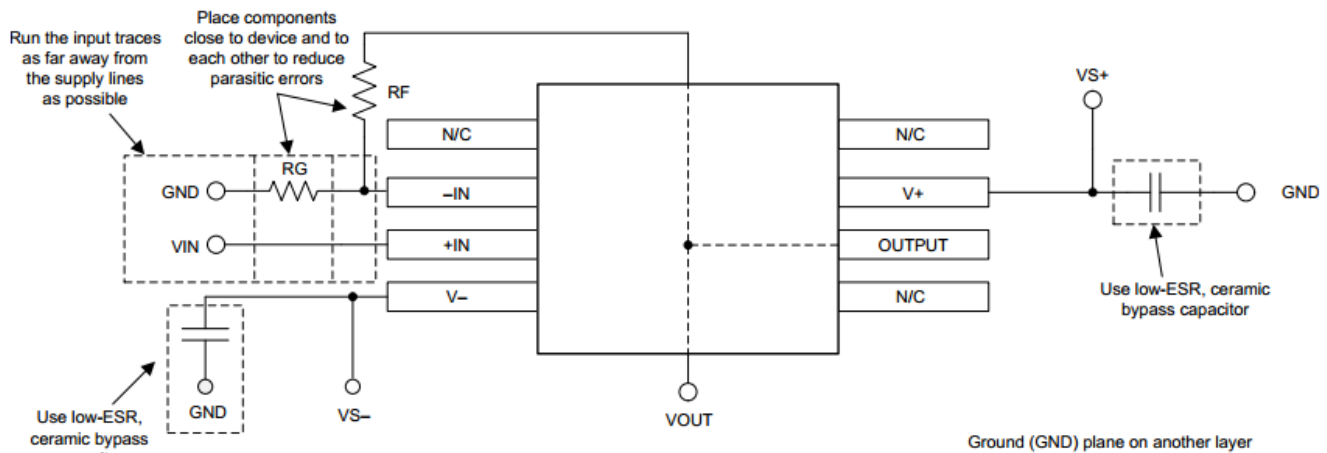

**图 39. Operational Amplifier Board Layout for Noninverting Configuration**

### 11.3 Power Dissipation

Power dissipation depends on power-supply voltage, signal and load conditions. With DC signals, power dissipation is equal to the product of output current times the voltage across the conducting output transistor,  $V_S - V_O$ . Power dissipation is minimized by using the lowest possible power-supply voltage necessary to assure the required output voltage swing.

For resistive loads, the maximum power dissipation occurs at a DC output voltage of one-half the power-supply voltage. Dissipation with AC signals is lower. [AB-039 Power Amplifier Stress and Power Handling Limitations](#) explains how to calculate or measure power dissipation with unusual signals and loads. See [www.ti.com](http://www.ti.com) for more details.



## Power Dissipation (接下页)

Any tendency to activate the thermal protection circuit indicates excessive power dissipation or an inadequate heat sink. For reliable operation, junction temperature must be limited to 150°C (maximum.) To estimate the margin of safety in a complete design, increase the ambient temperature until the thermal protection is triggered at 160°C. The thermal protection must trigger more than 35°C above the maximum expected ambient condition of the application.

### 11.4 PowerPAD Thermally-Enhanced Package

In addition to the regular 5-pin SOT-23 and 9-pin VSSOP packages, the single and dual versions of the OPAx354 also come in an 8-pin SOIC PowerPAD package. The 98-pin SO with PowerPAD is a standard size 8-pin SOIC package where the exposed leadframe on the bottom of the package is soldered directly to the PCB to create a low thermal resistance. This direct attachment enhances the OPAx354 power dissipation capability significantly, and eliminates the use of bulky heat sinks and slugs that are traditionally used in thermal packages. This package is easily mounted using standard PCB assembly techniques.

#### 注

Because the 8-pin HSOP PowerPAD is pin-compatible with standard 8-pin SOIC packages, the OPA354 and OPA2354 can directly replace operational amplifiers in existing sockets. Soldering the PowerPAD to the PCB is always required, even with applications that have low power dissipation. This configuration provides the necessary thermal and mechanical connection between the leadframe die pad and the PCB.

The PowerPAD package is designed so that the leadframe die pad (or thermal pad) is exposed on the bottom of the device, as shown in 图 40. This exposed die provides an extremely low thermal resistance ( $R_{\theta JC}$ ) path between the die and the exterior of the package. The thermal pad on the bottom of the device can then be soldered directly to the PCB, using the PCB as a heat sink. In addition, plated-through holes (vias) provide a low thermal resistance heat flow path to the back side of the PCB.



图 40. Section View of a PowerPAD Package

### 11.5 PowerPAD Assembly Process

The PowerPAD must be connected to the most negative supply voltage for the device, which is ground in single-supply applications and  $V^-$  in split-supply applications.

Prepare the PCB with a top-side etch pattern, as shown in 图 41. The exact land design may vary based on the specific assembly process requirements. There must be etch for the leads and etch for the thermal land.

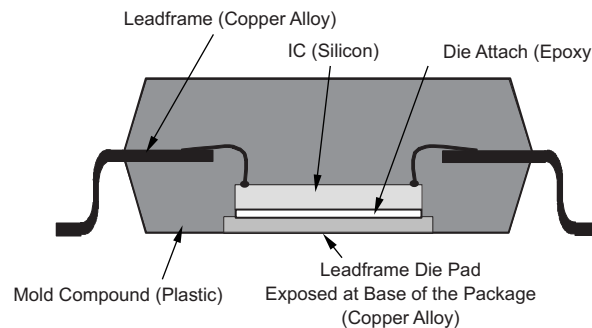
Place the recommended number of plated-through holes (or thermal vias) in the area of the thermal pad. These holes must be 13 mils (.013 in) in diameter. The holes are small so that solder wicking through the holes is not a problem during reflow. TI recommends a minimum of five holes for the 8-pin HSOP PowerPAD package, as shown in 图 41.

## PowerPAD Assembly Process (接下页)



图 41. 8-Pin PowerPAD PCB Etch and Via Pattern

TI recommends, but does not require, placing a small number of additional holes under the package and outside the thermal pad area. These holes provide additional heat paths between the copper thermal land and the ground plane. The holes may be larger because the holes are not in the area to be soldered, so wicking is not a problem. This technique is shown in 图 41.

Connect all holes, including those within the thermal pad area and outside the pad area, to the internal ground plane or other internal copper plane for single-supply applications, and to V- for split-supply applications.

When laying out these holes, do not use the typical web or spoke via connection methodology, as shown in 图 42. Web connections have a high thermal resistance connection that is useful for slowing the heat transfer during soldering operations. This feature makes soldering the vias that have ground plane connections easier. However, in this application, low thermal resistance is desired for the most efficient heat transfer. Therefore, the holes under the PowerPAD package must make connection to the internal ground plane with a complete connection around the entire circumference of the plated-through hole.

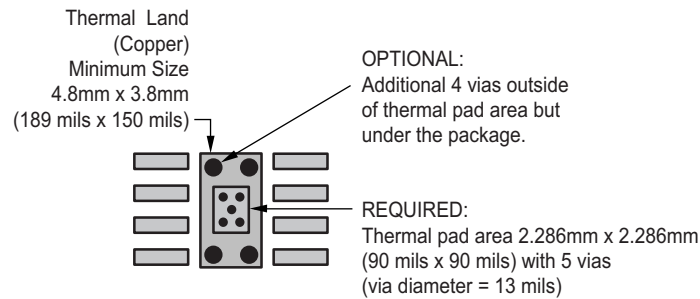

图 42. Via Connection

The top-side solder mask must leave the pad connections and the thermal pad area exposed. The thermal pad area must leave the 13-mil holes exposed. The larger holes outside the thermal pad area may be covered with a solder mask.

Apply solder paste to the exposed thermal pad area and all of the package pins.

With these preparatory steps in place, the PowerPAD device is placed in position and run through the solder reflow operation as any standard surface-mount component. This preparation and processing results in a part that is properly installed.

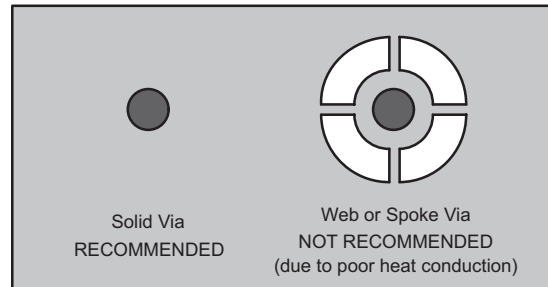
For detailed information on the PowerPAD package, including thermal modeling considerations and repair procedures, see [PowerPAD Thermally Enhanced Package](#) on [www.ti.com](http://www.ti.com).

## 12 器件和文档支持

### 12.1 文档支持

相关文档请参见以下部分：

- 德州仪器 (TI), 《[ADS8326 16 位、2.7V 至 5.5V 高速低功耗采样模数转换器](#)》
- 德州仪器 (TI), 《[电路板布局技巧](#)》
- 德州仪器 (TI), 《[用直观方式补偿跨阻放大器](#)》
- 德州仪器 (TI), 《[FilterPro™ 用户指南](#)》
- 德州仪器 (TI), 《[高速运算放大器噪声分析](#)》
- 德州仪器 (TI), 《[OPA380 和 OPA2380 精密高速跨阻放大器](#)》
- 德州仪器 (TI), 《[具有关断功能的 OPA355、OPA2355 和 OPA3355 200MHz CMOS 运算放大器](#)》
- 德州仪器 (TI), 《[OPA656 宽带单位增益稳定 FET 输入运算放大器](#)》
- 德州仪器 (TI), 《[功率放大器应力和功率处理限制](#)》
- 德州仪器 (TI), 《[PowerPAD 热增强型封装](#)》

### 12.2 相关链接

表 2 列出了快速访问链接。类别包括技术文档、支持和社区资源、工具和软件以及申请样片或购买产品的快速访问链接。

表 2. 相关链接

器件	产品文件夹	立即订购	技术文档	工具和软件	支持和社区
OPA354	<a href="#">单击此处</a>	<a href="#">单击此处</a>	<a href="#">单击此处</a>	<a href="#">单击此处</a>	<a href="#">单击此处</a>
OPA2354	<a href="#">单击此处</a>	<a href="#">单击此处</a>	<a href="#">单击此处</a>	<a href="#">单击此处</a>	<a href="#">单击此处</a>
OPA4354	<a href="#">单击此处</a>	<a href="#">单击此处</a>	<a href="#">单击此处</a>	<a href="#">单击此处</a>	<a href="#">单击此处</a>

### 12.3 接收文档更新通知

如需接收文档更新通知，请访问 [TI.com.cn](http://TI.com.cn) 网站上的器件产品文件夹。单击右上角的通知我进行注册，即可每周接收产品信息更改摘要。有关更改的详细信息，请查看任何已修订文档中包含的修订历史记录。

### 12.4 社区资源

下列链接提供到 TI 社区资源的连接。链接的内容由各个分销商“按照原样”提供。这些内容并不构成 TI 技术规范，并且不一定反映 TI 的观点；请参阅 TI 的《[使用条款](#)》。

**TI E2E™ 在线社区** [TI 的工程师对工程师 \(E2E\) 社区](#)。此社区的创建目的在于促进工程师之间的协作。在 [e2e.ti.com](http://e2e.ti.com) 中，您可以咨询问题、分享知识、拓展思路并与同行工程师一道帮助解决问题。

**设计支持** [TI 参考设计支持](#) 可帮助您快速查找有帮助的 E2E 论坛、设计支持工具以及技术支持的联系信息。

### 12.5 商标

PowerPAD, E2E are trademarks of Texas Instruments.  
All other trademarks are the property of their respective owners.

### 12.6 静电放电警告



这些装置包含有限的内置 ESD 保护。存储或装卸时，应将导线一起截短或将装置放置于导电泡棉中，以防止 MOS 门极遭受静电损伤。

### 12.7 术语表

**SLYZ022** — TI 术语表。

这份术语表列出并解释术语、缩写和定义。

### 13 机械、封装和可订购信息

以下页面包含机械、封装和可订购信息。这些信息是指定器件的最新可用数据。数据如有变更，恕不另行通知，且不会对此文档进行修订。如需获取此数据表的浏览器版本，请参阅左侧的导航栏。

**PACKAGING INFORMATION**

Orderable Device	Status (1)	Package Type	Package Drawing	Pins	Package Qty	Eco Plan (2)	Lead finish/ Ball material (6)	MSL Peak Temp (3)	Op Temp (°C)	Device Marking (4/5)	Samples
OPA2354AIDDA	ACTIVE	SO PowerPAD	DDA	8	75	RoHS & Green	SN	Level-1-260C-UNLIM	-40 to 125	OPA 2354A	<a href="#">Samples</a>
OPA2354AIDDAG3	ACTIVE	SO PowerPAD	DDA	8	75	RoHS & Green	SN	Level-1-260C-UNLIM	-40 to 125	OPA 2354A	<a href="#">Samples</a>
OPA2354AIDDAR	ACTIVE	SO PowerPAD	DDA	8	2500	RoHS & Green	SN	Level-1-260C-UNLIM	-40 to 125	OPA 2354A	<a href="#">Samples</a>
OPA2354AIDDARG3	ACTIVE	SO PowerPAD	DDA	8	2500	RoHS & Green	SN	Level-1-260C-UNLIM	-40 to 125	OPA 2354A	<a href="#">Samples</a>
OPA2354AIDGKR	ACTIVE	VSSOP	DGK	8	2500	RoHS & Green	Call TI   SN   NIPDAUAG	Level-2-260C-1 YEAR	-40 to 125	OACI	<a href="#">Samples</a>
OPA2354AIDGKT	ACTIVE	VSSOP	DGK	8	250	RoHS & Green	Call TI   SN   NIPDAUAG	Level-2-260C-1 YEAR	-40 to 125	OACI	<a href="#">Samples</a>
OPA2354AIDGKTG4	ACTIVE	VSSOP	DGK	8	250	RoHS & Green	Call TI	Level-2-260C-1 YEAR	-40 to 125	OACI	<a href="#">Samples</a>
OPA354AIDBVR	ACTIVE	SOT-23	DBV	5	3000	RoHS & Green	NIPDAU	Level-2-260C-1 YEAR	-40 to 125	OABI	<a href="#">Samples</a>
OPA354AIDBVT	ACTIVE	SOT-23	DBV	5	250	RoHS & Green	NIPDAU	Level-2-260C-1 YEAR	-40 to 125	OABI	<a href="#">Samples</a>
OPA354AIDBVTG4	ACTIVE	SOT-23	DBV	5	250	RoHS & Green	NIPDAU	Level-2-260C-1 YEAR	-40 to 125	OABI	<a href="#">Samples</a>
OPA354AIDDA	ACTIVE	SO PowerPAD	DDA	8	75	RoHS & Green	SN	Level-1-260C-UNLIM	-40 to 125	OPA 354A	<a href="#">Samples</a>
OPA354AIDDAG3	ACTIVE	SO PowerPAD	DDA	8	75	RoHS & Green	SN	Level-1-260C-UNLIM	-40 to 125	OPA 354A	<a href="#">Samples</a>
OPA354AIDDAR	ACTIVE	SO PowerPAD	DDA	8	2500	RoHS & Green	SN	Level-1-260C-UNLIM	-40 to 125	OPA 354A	<a href="#">Samples</a>
OPA4354AID	ACTIVE	SOIC	D	14	50	RoHS & Green	NIPDAU	Level-2-260C-1 YEAR	-40 to 125	OPA4354A	<a href="#">Samples</a>
OPA4354AIDR	ACTIVE	SOIC	D	14	2500	RoHS & Green	NIPDAU	Level-2-260C-1 YEAR	-40 to 125	OPA4354A	<a href="#">Samples</a>
OPA4354AIPWR	ACTIVE	TSSOP	PW	14	2500	RoHS & Green	NIPDAU	Level-2-260C-1 YEAR	-40 to 125	OPA 4354A	<a href="#">Samples</a>
OPA4354AIPWRG4	ACTIVE	TSSOP	PW	14	2500	RoHS & Green	NIPDAU	Level-2-260C-1 YEAR	-40 to 125	OPA 4354A	<a href="#">Samples</a>
OPA4354AIPWT	ACTIVE	TSSOP	PW	14	250	RoHS & Green	NIPDAU	Level-2-260C-1 YEAR	-40 to 125	OPA 4354A	<a href="#">Samples</a>

(1) The marketing status values are defined as follows:

**ACTIVE:** Product device recommended for new designs.

**LIFEBUY:** TI has announced that the device will be discontinued, and a lifetime-buy period is in effect.

**NRND:** Not recommended for new designs. Device is in production to support existing customers, but TI does not recommend using this part in a new design.

**PREVIEW:** Device has been announced but is not in production. Samples may or may not be available.

**OBSOLETE:** TI has discontinued the production of the device.

(2) **RoHS:** TI defines "RoHS" to mean semiconductor products that are compliant with the current EU RoHS requirements for all 10 RoHS substances, including the requirement that RoHS substance do not exceed 0.1% by weight in homogeneous materials. Where designed to be soldered at high temperatures, "RoHS" products are suitable for use in specified lead-free processes. TI may reference these types of products as "Pb-Free".

**RoHS Exempt:** TI defines "RoHS Exempt" to mean products that contain lead but are compliant with EU RoHS pursuant to a specific EU RoHS exemption.

**Green:** TI defines "Green" to mean the content of Chlorine (Cl) and Bromine (Br) based flame retardants meet JS709B low halogen requirements of  $\leq 1000$ ppm threshold. Antimony trioxide based flame retardants must also meet the  $\leq 1000$ ppm threshold requirement.

(3) **MSL, Peak Temp.** - The Moisture Sensitivity Level rating according to the JEDEC industry standard classifications, and peak solder temperature.

(4) There may be additional marking, which relates to the logo, the lot trace code information, or the environmental category on the device.

(5) Multiple Device Markings will be inside parentheses. Only one Device Marking contained in parentheses and separated by a "~" will appear on a device. If a line is indented then it is a continuation of the previous line and the two combined represent the entire Device Marking for that device.

(6) **Lead finish/Ball material** - Orderable Devices may have multiple material finish options. Finish options are separated by a vertical ruled line. Lead finish/Ball material values may wrap to two lines if the finish value exceeds the maximum column width.

**Important Information and Disclaimer:** The information provided on this page represents TI's knowledge and belief as of the date that it is provided. TI bases its knowledge and belief on information provided by third parties, and makes no representation or warranty as to the accuracy of such information. Efforts are underway to better integrate information from third parties. TI has taken and continues to take reasonable steps to provide representative and accurate information but may not have conducted destructive testing or chemical analysis on incoming materials and chemicals. TI and TI suppliers consider certain information to be proprietary, and thus CAS numbers and other limited information may not be available for release.

In no event shall TI's liability arising out of such information exceed the total purchase price of the TI part(s) at issue in this document sold by TI to Customer on an annual basis.

#### **OTHER QUALIFIED VERSIONS OF OPA4354 :**

- Automotive : [OPA4354-Q1](#)

NOTE: Qualified Version Definitions:

- Automotive - Q100 devices qualified for high-reliability automotive applications targeting zero defects

**TAPE AND REEL INFORMATION**

**QUADRANT ASSIGNMENTS FOR PIN 1 ORIENTATION IN TAPE**

\*All dimensions are nominal

Device	Package Type	Package Drawing	Pins	SPQ	Reel Diameter (mm)	Reel Width W1 (mm)	A0 (mm)	B0 (mm)	K0 (mm)	P1 (mm)	W (mm)	Pin1 Quadrant
OPA2354AIDDAR	SO PowerPAD	DDA	8	2500	330.0	12.4	6.4	5.2	2.1	8.0	12.0	Q1
OPA2354AIDGKR	VSSOP	DGK	8	2500	330.0	12.4	5.3	3.4	1.4	8.0	12.0	Q1
OPA2354AIDGKR	VSSOP	DGK	8	2500	330.0	12.4	5.3	3.4	1.4	8.0	12.0	Q1
OPA2354AIDGKT	VSSOP	DGK	8	250	330.0	12.4	5.3	3.4	1.4	8.0	12.0	Q1
OPA2354AIDGKT	VSSOP	DGK	8	250	330.0	12.4	5.3	3.4	1.4	8.0	12.0	Q1
OPA354AIDBVR	SOT-23	DBV	5	3000	178.0	9.0	3.23	3.17	1.37	4.0	8.0	Q3
OPA354AIDBVT	SOT-23	DBV	5	250	178.0	9.0	3.3	3.2	1.4	4.0	8.0	Q3
OPA354AIDDAR	SO PowerPAD	DDA	8	2500	330.0	12.4	6.4	5.2	2.1	8.0	12.0	Q1
OPA4354AIDR	SOIC	D	14	2500	330.0	16.4	6.5	9.0	2.1	8.0	16.0	Q1
OPA4354AIPWR	TSSOP	PW	14	2500	330.0	12.4	6.9	5.6	1.6	8.0	12.0	Q1
OPA4354AIPWT	TSSOP	PW	14	250	180.0	12.4	6.9	5.6	1.6	8.0	12.0	Q1

**TAPE AND REEL BOX DIMENSIONS**

\*All dimensions are nominal

Device	Package Type	Package Drawing	Pins	SPQ	Length (mm)	Width (mm)	Height (mm)
OPA2354AIDDAR	SO PowerPAD	DDA	8	2500	356.0	356.0	35.0
OPA2354AIDGKR	VSSOP	DGK	8	2500	366.0	364.0	50.0
OPA2354AIDGKR	VSSOP	DGK	8	2500	366.0	364.0	50.0
OPA2354AIDGKT	VSSOP	DGK	8	250	366.0	364.0	50.0
OPA2354AIDGKT	VSSOP	DGK	8	250	366.0	364.0	50.0
OPA354AIDBVR	SOT-23	DBV	5	3000	180.0	180.0	18.0
OPA354AIDBVT	SOT-23	DBV	5	250	180.0	180.0	18.0
OPA354AIDDAR	SO PowerPAD	DDA	8	2500	356.0	356.0	35.0
OPA4354AIDR	SOIC	D	14	2500	356.0	356.0	35.0
OPA4354AIPWR	TSSOP	PW	14	2500	356.0	356.0	35.0
OPA4354AIPWT	TSSOP	PW	14	250	210.0	185.0	35.0



**TUBE**

\*All dimensions are nominal

Device	Package Name	Package Type	Pins	SPQ	L (mm)	W (mm)	T (μm)	B (mm)
OPA2354AIDDA	DDA	HSOIC	8	75	506.6	8	3940	4.32
OPA2354AIDDAG3	DDA	HSOIC	8	75	506.6	8	3940	4.32
OPA354AIDDA	DDA	HSOIC	8	75	506.6	8	3940	4.32
OPA354AIDDAG3	DDA	HSOIC	8	75	506.6	8	3940	4.32
OPA4354AID	D	SOIC	14	50	506.6	8	3940	4.32



Images above are just a representation of the package family, actual package may vary.  
Refer to the product data sheet for package details.

# DDA0008D



# PACKAGE OUTLINE

## PowerPAD™ SOIC - 1.7 mm max height

PLASTIC SMALL OUTLINE

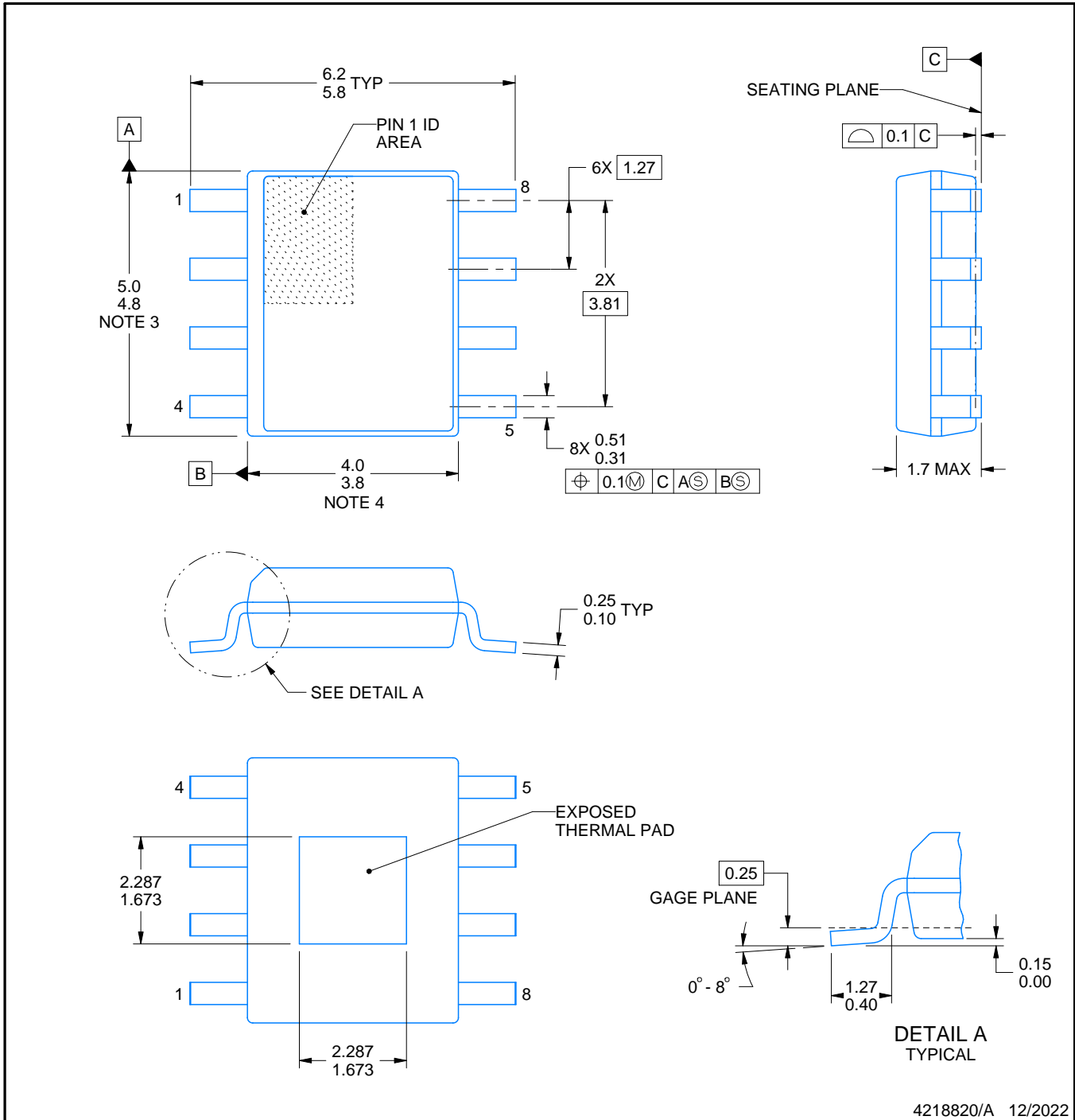

4218820/A 12/2022

PowerPAD is a trademark of Texas Instruments.

### NOTES:

1. All linear dimensions are in millimeters. Any dimensions in parenthesis are for reference only. Dimensioning and tolerancing per ASME Y14.5M.
2. This drawing is subject to change without notice.
3. This dimension does not include mold flash, protrusions, or gate burrs. Mold flash, protrusions, or gate burrs shall not exceed 0.15 mm per side.
4. This dimension does not include interlead flash. Interlead flash shall not exceed 0.25 mm per side.
5. Reference JEDEC registration MS-012, variation BA.



# EXAMPLE STENCIL DESIGN

DDA0008D

PowerPAD™ SOIC - 1.7 mm max height

PLASTIC SMALL OUTLINE

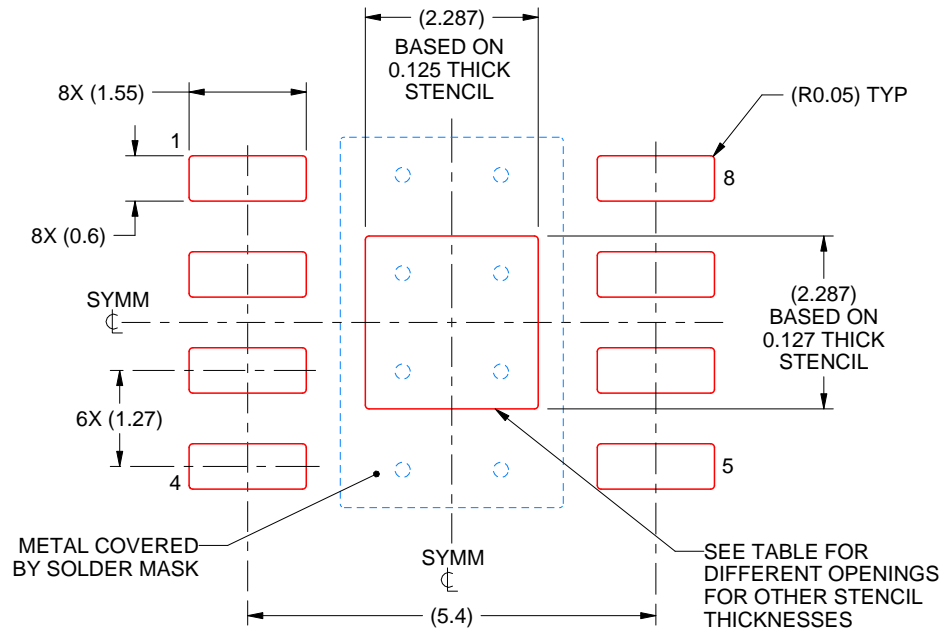

SOLDER PASTE EXAMPLE  
 EXPOSED PAD  
 100% PRINTED SOLDER COVERAGE BY AREA  
 SCALE:10X

STENCIL THICKNESS	SOLDER STENCIL OPENING
0.1	2.557 X 2.557
0.125	2.287 X 2.287 (SHOWN)
0.150	2.088 X 2.088
0.175	1.933 X 1.933

4218820/A 12/2022

NOTES: (continued)

- 10. Laser cutting apertures with trapezoidal walls and rounded corners may offer better paste release. IPC-7525 may have alternate design recommendations.
- 11. Board assembly site may have different recommendations for stencil design.

DBV0005A



# PACKAGE OUTLINE

SOT-23 - 1.45 mm max height

SMALL OUTLINE TRANSISTOR

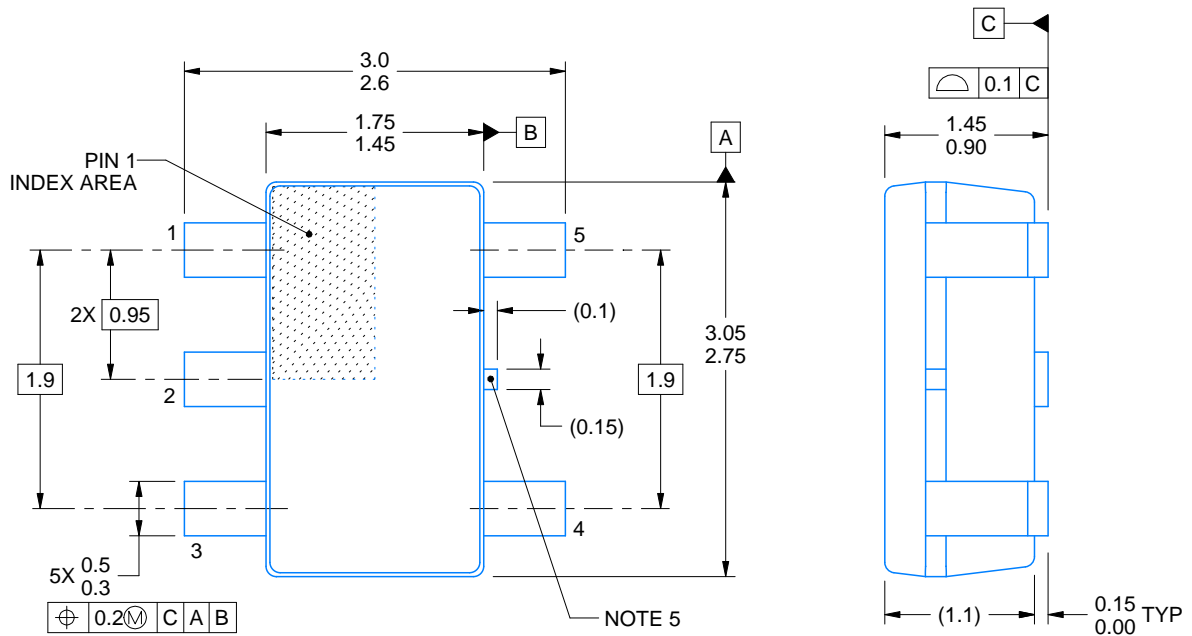

4214839/G 03/2023

## NOTES:

1. All linear dimensions are in millimeters. Any dimensions in parenthesis are for reference only. Dimensioning and tolerancing per ASME Y14.5M.
2. This drawing is subject to change without notice.
3. Reference JEDEC MO-178.
4. Body dimensions do not include mold flash, protrusions, or gate burrs. Mold flash, protrusions, or gate burrs shall not exceed 0.25 mm per side.
5. Support pin may differ or may not be present.

# EXAMPLE BOARD LAYOUT

DBV0005A

SOT-23 - 1.45 mm max height

SMALL OUTLINE TRANSISTOR



LAND PATTERN EXAMPLE  
EXPOSED METAL SHOWN  
SCALE:15X



SOLDER MASK DETAILS

4214839/G 03/2023

NOTES: (continued)

- 6. Publication IPC-7351 may have alternate designs.
- 7. Solder mask tolerances between and around signal pads can vary based on board fabrication site.

# EXAMPLE STENCIL DESIGN

DBV0005A

SOT-23 - 1.45 mm max height

SMALL OUTLINE TRANSISTOR



SOLDER PASTE EXAMPLE  
BASED ON 0.125 mm THICK STENCIL  
SCALE:15X

4214839/G 03/2023

NOTES: (continued)

8. Laser cutting apertures with trapezoidal walls and rounded corners may offer better paste release. IPC-7525 may have alternate design recommendations.
9. Board assembly site may have different recommendations for stencil design.





D (R-PDSO-G14)

PLASTIC SMALL OUTLINE



4211283-3/E 08/12

- NOTES:
- All linear dimensions are in millimeters.
  - This drawing is subject to change without notice.
  - Publication IPC-7351 is recommended for alternate designs.
  - Laser cutting apertures with trapezoidal walls and also rounding corners will offer better paste release. Customers should contact their board assembly site for stencil design recommendations. Refer to IPC-7525 for other stencil recommendations.
  - Customers should contact their board fabrication site for solder mask tolerances between and around signal pads.



PW (R-PDSO-G14)

PLASTIC SMALL OUTLINE



- NOTES:
- All linear dimensions are in millimeters.
  - This drawing is subject to change without notice.
  - Publication IPC-7351 is recommended for alternate designs.
  - Laser cutting apertures with trapezoidal walls and also rounding corners will offer better paste release. Customers should contact their board assembly site for stencil design recommendations. Refer to IPC-7525 for other stencil recommendations.
  - Customers should contact their board fabrication site for solder mask tolerances between and around signal pads.

DGK (S-PDSO-G8)

PLASTIC SMALL-OUTLINE PACKAGE



4073329/E 05/06

- NOTES:
- A. All linear dimensions are in millimeters.
  - B. This drawing is subject to change without notice.
  - C. Body length does not include mold flash, protrusions, or gate burrs. Mold flash, protrusions, or gate burrs shall not exceed 0.15 per end.
  - D. Body width does not include interlead flash. Interlead flash shall not exceed 0.50 per side.
  - E. Falls within JEDEC MO-187 variation AA, except interlead flash.



- NOTES:
- A. All linear dimensions are in millimeters.
  - B. This drawing is subject to change without notice.
  - C. Publication IPC-7351 is recommended for alternate designs.
  - D. Laser cutting apertures with trapezoidal walls and also rounding corners will offer better paste release. Customers should contact their board assembly site for stencil design recommendations. Refer to IPC-7525 for other stencil recommendations.
  - E. Customers should contact their board fabrication site for solder mask tolerances between and around signal pads.

## 重要声明和免责声明

TI“按原样”提供技术和可靠性数据（包括数据表）、设计资源（包括参考设计）、应用或其他设计建议、网络工具、安全信息和其他资源，不保证没有瑕疵且不做任何明示或暗示的担保，包括但不限于对适销性、某特定用途方面的适用性或不侵犯任何第三方知识产权的暗示担保。

这些资源可供使用 TI 产品进行设计的熟练开发人员使用。您将自行承担以下全部责任：(1) 针对您的应用选择合适的 TI 产品，(2) 设计、验证并测试您的应用，(3) 确保您的应用满足相应标准以及任何其他功能安全、信息安全、监管或其他要求。

这些资源如有变更，恕不另行通知。TI 授权您仅可将这些资源用于研发本资源所述的 TI 产品的应用。严禁对这些资源进行其他复制或展示。您无权使用任何其他 TI 知识产权或任何第三方知识产权。您应全额赔偿因在这些资源的使用中对 TI 及其代表造成的任何索赔、损害、成本、损失和债务，TI 对此概不负责。

TI 提供的产品受 [TI 的销售条款](#) 或 [ti.com](#) 上其他适用条款/TI 产品随附的其他适用条款的约束。TI 提供这些资源并不会扩展或以其他方式更改 TI 针对 TI 产品发布的适用的担保或担保免责声明。

TI 反对并拒绝您可能提出的任何其他或不同的条款。

邮寄地址：Texas Instruments, Post Office Box 655303, Dallas, Texas 75265

Copyright © 2023，德州仪器 (TI) 公司