

TMS570LS 系列 16/32 位精简指令集计算机 (RISC) 闪存微控制器

 查询样品: [TMS570LS20206-EP](#), [TMS570LS20216-EP](#)

1 TMS570LS 系列 16/32 位 RISC 闪存微控制器

1.1 特性

- 虽然 **TMS570LS20206-EP** 和 **TMS570LS20216-EP** 使用与经 **IEC 61508 SIL3** 认证的 **TMS570LS** 微控制器系列产品一样的芯片, 但这两个器件是经认证符合 **GEIA-STD-00021-1** 标准的航空航天级别电子元件, 并且经测试可在军用温度范围内运行。
- 高性能微控制器
 - 运行在锁步中的双中央处理单元 (CPU)
 - 闪存和 **SRAM** 上的错误校正码 (ECC)
 - CPU 和内存 **BIST** (内置自检)
 - 带有错误引脚的错误信令模块 (ESM)
- **ARM® Cortex™-R4F 32 位 RISC CPU**
 - 具有 8 级管线的高效 1.6 每兆赫每秒百万次整数运算指令 (DMIPS/MHz)
 - 带有单精度/双精度的浮点单元
 - 内存保护单元 (MPU)
 - 带有第三方支持的开放式架构
- 运行特性
 - 高达 160MHz 系统时钟
 - 内核电源电压 (V_{CC}): 1.5V
 - I/O 电源电压 (V_{CCIO}): 3.3V
- 集成内存
 - 支持 ECC 的 2M 字节闪存
 - 支持 ECC 的 60K 字节 RAM
- 包括 **FlexRay**, 控制器局域网 (CAN), 和本地互连网络 (LIN) 在内的多种通信接口
- **NHET** 定时器和 2x 12 位模数转换器 (ADC)
- 外部存储器接口 (EMIF)
 - 16 位数据、22 位地址、4 芯片选择
- 公共 **TMS570** 平台架构
 - 系列产品上的一致内存映射
 - 实时中断 (RTI) 操作系统 (OS) 定时器
 - 矢量中断模块 (VIM)
 - 循环冗余校验器 (CRC, 2 通道)
- 直接内存访问 (DMA) 控制器
 - 32 DMA 请求和 16 通道/控制数据包
 - 控制数据包内存上的奇偶校验
 - 专用内存保护单元 (MPU)
- 基于调频零引脚锁相环 (FMzPLL) 的时钟模块
 - 振荡器和 PLL 时钟监视器
- 高达 115 个外设 IO 引脚
 - 16 个专用 GIO - 其中 8 个有外部中断
 - 可编程外部时钟 (ECLK)
- 通信接口
 - 三个多缓冲串行外设接口 (MibSPI), 每个接口具有:
 - 四个芯片选择和一个使能引脚
 - 128 个支持奇偶校验的缓冲器
 - 一个具有并行模式
 - 两个带有本地互连网络接口 (LIN 2.0) 的通用异步收发器 (SCI) 接口
 - 三个 CAN (DCAN) 控制器
 - 其中两个带有 64 个邮箱, 另外一个有 32 个邮箱
 - 邮箱 RAM 上的奇偶校验
 - 双通道 **FlexRay™** 控制器
 - 支持奇偶校验的 8K 字节消息 RAM
 - 带有 MPU 和奇偶校验的传输单元
- 高端定时器 (NHET)
 - 32 个可编程 I/O 通道
 - 支持奇偶校验的 128 字高端定时器 RAM
 - 带有 MPU 和奇偶校验的传输单元
- 两个 12 位多缓冲 ADC (MibADC)
 - 总共 24 个 ADC 输入通道
 - 每个通道有 64 个支持奇偶校验的缓冲器
- 跟踪和校准接口
 - 嵌入式跟踪模块 (ETMR4)
 - 数据修改模块 (DMM)
 - RAM 跟踪端口 (RTP)
 - 参数覆盖模块 (POM)
- 包括 **IEEE 1149.1 JTAG**, 边界扫描和 **ARM Coresight** 组件的片载仿真逻辑
- 提供完整的开发工具包
 - 开发板
 - **Code Composer Studio** 集成开发环境 (IDE)
 - **HaLCoGen** 代码生成工具
 - 高端定时器 (HET) 汇编程序和模拟器
 - **nowFlash** 闪存编辑工具



Please be aware that an important notice concerning availability, standard warranty, and use in critical applications of Texas Instruments semiconductor products and disclaimers thereto appears at the end of this data sheet.

- 支持的封装
 - 337 引脚球状栅格阵列封装 (GWT)
 - 144 引脚有盖四方扁平 (PGE) 封装
- 社区资源
 - [TI E2E 社区](#)

1.2 支持国防和航空航天应用

- 受控基线
- 一个组装/测试场所
- 一个制造场所
- 额定温度为 **-55°C 至 125°C**
- 延长的产品生命周期
- 延长的产品变更通知
- 产品可追溯性

1.3 说明

TMS570LS 是一款高性能微控制器系列产品。此架构包括锁步中的双 CPU，CPU 和内存内置自检 (BIST) 逻辑，闪存和数据 RAM 上的 ECC，外设内存上的奇偶校验，和外设 IO 上的回路功能。

TMS570LS 系列集成了 ARM® Cortex™-R4F 浮点 CPU，该 CPU 提供了高效的 1.6 DMIPS/MHz，并且具有可运行至高达 160MHz 的配置，从而提供大于 250 DMIPS 的指令执行速度。TMS570LS 系列还提供具有单一位错误校正和双位错误检测的闪存 (2MB) 和数据 SRAM (160KB) 选项。

TMS570LS 特有用于基于实时控制应用的外设，其中包括高达 32 nHET 的定时器通道和两个支持高达 24 个输入的 12 位模数转换器。有多个通信接口，其中包括一个 2 通道 FlexRay，3 个 CAN 控制器，每个控制器支持 64 个邮箱，和 2 个 LIN/UART 控制器。

借助于多个可选的通信和控制外设，TMS570LS 系列是一个针对高性能实时控制应用的理想解决方案。

包括在 TMS570LS 系列并在本文档中进行说明的器件有：

- TMS570LS20206
- TMS570LS20216

TMS570LS 系列微控制器包含下列组件：

- 锁步中的双 TMS570 16/32 位 RISC (ARM Cortex™-R4F)
- 支持 ECC 的高达 2M 字节的程序闪存
- 支持 ECC 的高达 160K 字节的静态 RAM (SRAM)
- 实时中断 (RTI) 操作系统定时器
- 矢量中断模块 (VIM)
- 循环冗余校验器 (CRC) 支持并行特征值分析 (PSA)
- 直接内存访问 (DMA) 控制器
- 带前置分频器的基于调频锁相环 (FMzPLL) 的时钟模块
- 三个多缓冲串行外设接口 (MibSPI)
- 两个具有本地互连网络接口 (LIN) 的 UART (SCI)
- 三个 CAN 控制器 (DCAN)
- 带有专用传输单元 (HTU) 的高端定时器 (NHET)
- 提供带有专用 PLL 和传输单元 (FTU) 的 FlexRay 控制器
- 外部时钟前置分频 (ECP) 模块
- 两个 16 通道 12 位多缓冲 ADC (MibADC) - 其中 8 个通道由两个 ADC 共用
- 支持故障检测的地址总线奇偶校验
- 带有外部错误引脚的错误信令模块 (ESM)
- 支持超范围复位置位的电压监控器 (VMON)
- 嵌入式跟踪模块 (ETMR4)
- 数据修正模块 (DMM)
- RAM 跟踪端口 (RTP)
- 参数覆盖模块 (POM)
- 对于 GWT 封装，有 16 个专用通用 I/O (GIO) 引脚；对于 PGE 封装，有 8 个专用 GIO 引脚
- 对于 GWT 封装，总共 115 个外设 I/O；对于 PGE 封装，总共 68 个外设 I/O
- 16 位外部存储器接口 (EMIF)

此器件运用大端序 (big-endian) 格式，在该格式中，一个字的最高有效字节被存储于编号最小的字节中，而最低有效字节则存储在编号最大的字节中。

器件内存包括通用 SRAM，此 SRAM 支持字节模式、半字模式及字模式的单周期读/写访问。这个器件上的闪存存储器是一个由 64 位宽数据总线接口实现的非易失性、电可擦除并且可编程的存储器。为了实现所有读取、编程和擦除操作，此闪存运行在一个 3.3V 电源输入上（与 I/O 电源一样的电平）。当处于管线模式中时，闪存可在高达 160MHz 的系统时钟频率下运行。

此器件有 9 个通信接口：3 个 MibSPI，2 个 LIN/SCI，3 个 DCAN 和 1 个 FlexRay™ 控制器（可选。）SPI 为相似的移位寄存器类型器件之间的高速通信提供了一种便捷的串行交互方法。LIN 支持本地互联标准 2.0 并可被用作一个使用标准不归零码 (NRZ) 格式的全双工模式 UART。DCAN 支持 CAN 2.0B 协议标准并使用一个串行、多主机通信协议，此协议有效支持对速率高达 1 兆位每秒 (Mbps) 的稳健通信的分布式实时控制，DCAN 是要求可靠串行通信或者多路复用布线并在嘈杂和恶劣环境中运行的应用的理想选择。FlexRay 使用一个双通道串行、固定时基多主机通信协议，在此协议下，每通道的通信速率为 10 兆位每秒 (Mbps)。一个 FlexRay 传输单元 (FTU) 可实现 FlexRay 数据到主 CPU 内存的匿名传输和读取。数据传输受到一个专用、内置内存保护单元 (MPU) 的保护。

NHET 是一款先进的智能定时器，此定时器可为实时应用提供精密的定时功能。该定时器为软件控制型，采用一个精简指令集，并具有一个专用的定时器微级机和一个连接的 I/O 端口。NHET 可被用于脉宽调制输出、捕捉或者比较输入，或者通用 I/O。它特别适合于那些需要多种传感器信息和驱动传动器并具有复杂和准确的时间脉冲的应用。一个高端定时器传输单元 (HET-TU) 提供了将 NHET 数据存入主内存或者从主内存读出 NHET 数据的特性。为了防止错误传输，在 HET-TU 内部有一个内存保护单元 (MPU)。

此器件具有 2 个 12 位分辨率 MibADC，每个 MibADC 具有总共 24 个通道和受 64 字奇偶校验保护的缓冲器 RAM。MibADC 通道可被独立转换或者可针对顺序转换序列由软件成组。2 个 ADC 共用 8 个通道。有 3 个独立分组，其中的 2 个分组由一个外部事件触发。每个序列可在被触发时执行一次转换，或者被配置成连续转换模式。

调频锁相环 (FMzPLL) 时钟模块包含一个锁相环、一个时钟监视器电路、一个时钟启用电路，和一个前置分频器。FMzPLL 的功能是将外部频率基准倍频至一个供内部使用的较高频率。FMzPLL 为全局时钟模块 (GCM) 提供 6 个可能时钟源输入中的一个。GCM 模块向所有其它的外设模块提供系统时钟 (HCLK)，实时中断时钟 (RTICLK1)，CPU 时钟 (GCLK)，NHET 时钟 (VCLK2)，DCAN 时钟 (AVCLK1)，以及外设接口时钟 (VCLK)。

此器件还有一个外部时钟前置分频器 (ECP) 模块，当被启用时，此模块在 ECLK 引脚上输出一个连续外部时钟。ECLK 频率是一个外设接口时钟 (VCLK) 频率的用户可编程比例。

直接内存访问控制器 (DMA) 有 32 个 DMA 请求，16 个通道/控制数据包和对其内存的奇偶校验保护。无需 CPU 配合，DMA 即可提供内存到内存传输功能。为了防止内存发生错误传输，DMA 内置了一个内存保护单元 (MPU)。

错误信令模块 (ESM) 监控所有器件错误并在检测到一个故障时确定是触发一个中断还是触发一个外部错误引脚。

外部内存接口 (EMIF) 提供到异步内存或者其它从器件的内存扩展。

提供几个接口来提高应用代码的调试能力。除了内置了 ARM Cortex™-R4F CoreSight™ 调试接口，一个外部跟踪宏单元 (ETM) 提供程序执行的指令和数据跟踪。为了实现仪器测量的目的，执行了一个 RAM 跟踪端口模块 (RTP) 来支持 CPU 或者任何其它主机执行的 RAM 访问的高速输出。一个直接内存模块 (DMM) 提供向器件内存写入外部数据的功能。RTP 和 DMM 对于应用代码的程序执行时间没有影响或者只有很小的影响。一个参数覆盖模块 (POM) 可将闪存访问重新路由至 EMIF，从而避免了闪存内参数更新所需的重编程步骤。

1.4 订购信息⁽¹⁾

T _A	封装	可订购 部件号	正面 标记	VID 号
-55°C 至 125°C	NFBGA (GWT)	S5LS20206ASGWTMEP	S20206ASGWTMEP	V62/12622-01YE
		S5LS20216ASGWTMEP	S20216ASGWTMEP	V62/12622-02YE
	薄型四方扁平 (LQFP) (PGE) 封装	S5LS20206ASPGEMEP	S20206ASPGEMEP	V62/12622-01XE
		S5LS20216ASPGEMEP	S20216ASPGEMEP	V62/12622-02XE

(1) 要获得最新的封装和订购信息，请参见本文档末尾的封装选项附录，或者浏览 TI 网站 www.ti.com。

1.5 功能方框图

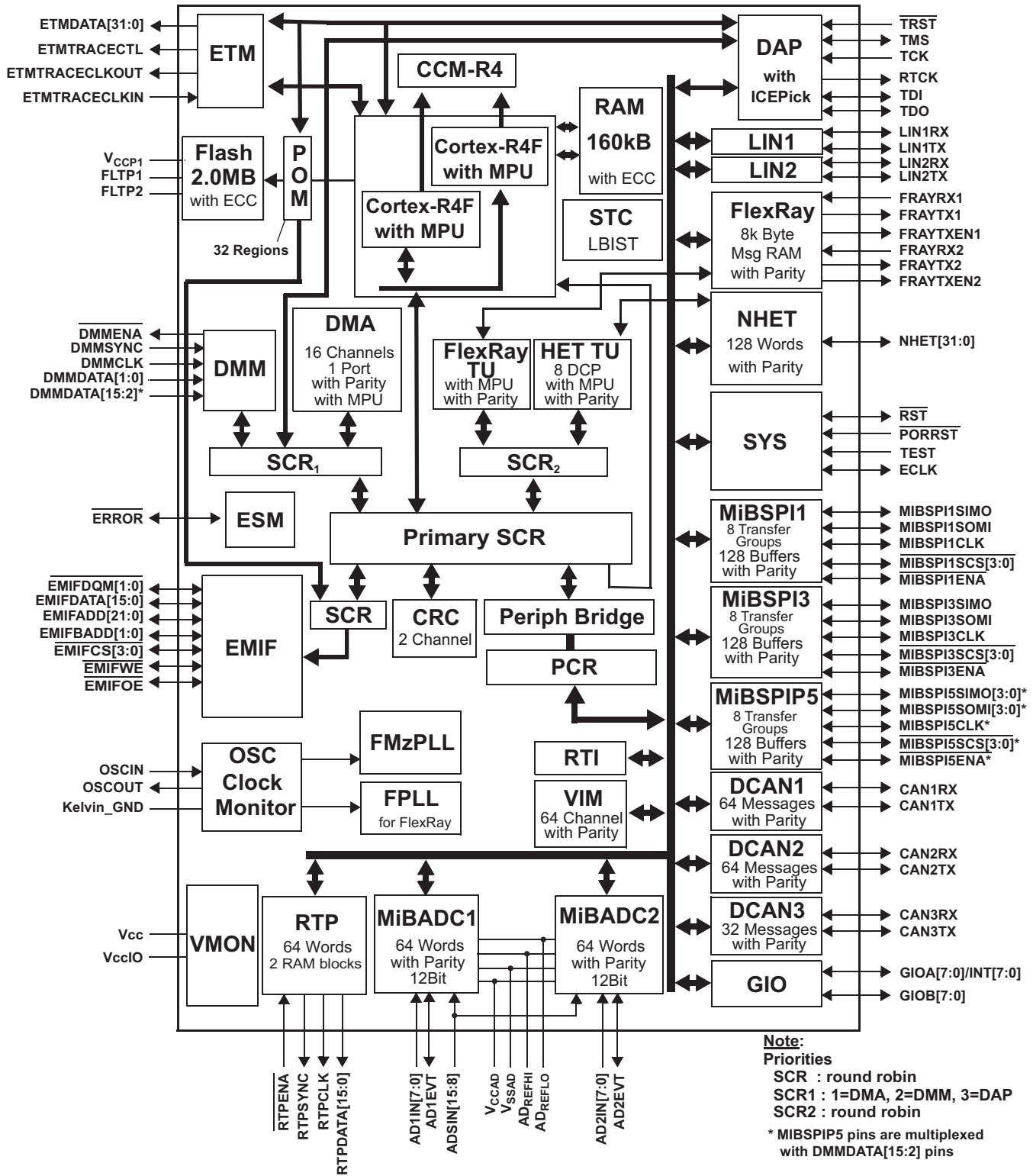

1	TMS570LS 系列 16/32 位 RISC 闪存微控制器	1	5.1	Device Identification Code Register	57
1.1	特性	1	5.2	Die-ID Registers	59
1.2	支持国防和航空航天应用	2	5.3	PLL Registers	60
1.3	说明	3	6	Device Electrical Specifications	61
1.4	订购信息	4	6.1	Operating Conditions	61
1.5	功能方框图	5	6.2	Absolute Maximum Ratings Over Operating Free-Air Temperature Range (unless otherwise noted)	61
2	Device Overview	7	6.3	Device Recommended Operating Conditions	61
2.1	Terms and Acronyms	7	6.4	Thermal Information	62
2.2	Device Characteristics	8	6.5	Electrical Characteristics Over Operating Free-Air Temperature Range	63
2.3	Memory	9	7	Peripheral and Electrical Specifications	67
2.4	Pin Assignments	17	7.1	Clocks	67
2.5	Terminal Functions	22	7.2	ECLK Specification	71
2.6	Device Support	35	7.3	RST And PORRST Timings	72
3	Reset / Abort Sources	37	7.4	TEST Pin Timing	74
3.1	Reset / Abort Sources	37	7.5	DAP - JTAG Scan Interface Timing	75
4	Peripherals	40	7.6	Output Timings	76
4.1	Error Signaling Module (ESM)	40	7.7	Input Timings	77
4.2	Direct Memory Access (DMA)	43	7.8	Flash Timings	78
4.3	High End Timer Transfer Unit (HET-TU)	44	7.9	SPI Master Mode Timing Parameters	79
4.4	Vectored Interrupt Manager (VIM)	45	7.10	SPI Slave Mode Timing Parameters	83
4.5	MIBADC Event Trigger Sources	47	7.11	CAN Controller Mode Timings	87
4.6	MIBSPI	48	7.12	SCI/LIN Mode Timings	87
4.7	ETM	50	7.13	FlexRay Controller Mode Timings	87
4.8	Debug Scan Chains	51	7.14	EMIF Timings	88
4.9	CCM	52	7.15	ETM Timings	90
4.10	LPM	53	7.16	RTP Timings	92
4.11	Voltage Monitor	53	7.17	DMM Timings	94
4.12	CRC	53	7.18	MibADC	95
4.13	System Module Access	53	8	Mechanical Packaging and Orderable Information	101
4.14	Debug ROM	54	8.1	Packaging Information	101
4.15	CPU Self Test Controller: STC / LBIST	55			
5	Device Registers	57			

2 Device Overview

2.1 Terms and Acronyms

Table 2-1. Terms and Acronyms

Terms and Acronyms	Description	Comments
ADC	Analog To Digital Converter	
AHB	Advanced High-performance Bus	Part of the R4 core
CCM-R4	CPU Compare Module for Cortex™-R4F	
CRC	Cyclic Redundancy Check Controller	
DAP	Debug Access Port	DAP is an implementation of an ARM Debug Interface.
DCAN	Controller Area Network	
DMA	Direct Memory Access	
DMM	Data Modification Module	
ECC	Error Correction Code	
EMIF	External Memory Interface	
ESM	Error Signaling Module	
ETM	Embedded Trace Module	
FMzPLL	Frequency-Modulated Zero-Pin Phase-Locked Loop	
FPLL	FlexRay Phase-Locked Loop	
GIO	General-Purpose Input/Output	
HET	High-End Timer	
ICEPICK	In Circuit Emulation TAP (Test Access Port) Selection Module	ICEPick can connect or isolate a module level TAP to or from a higher level chip TAP. ICEPick was designed with both emulation and test requirements in mind.
JTAG	Joint Test Access Group	IEEE Committee responsible for Test Access Ports
LBIST	Logic Built-In Self Test	Test the integrity of R4 CPU
LIN	Local Interconnect Network	
VIM	Vectored Interrupt Manager	
MibSPI	Multi-Buffered Serial Peripheral Interface	
MPU	Memory Protection Unit	
OSC	Oscillator	
PBIST	Programmable Built-In Self Test	Test the integrity of SRAM
PCR	Peripheral Central Resource	
POM	Parameter Overlay Module	The POM provides a mechanism to redirect accesses to non-volatile memory into a volatile memory external to the device.
PSA	Parallel Signature Analysis	
RTI	Real-Time Interrupt	
RTP	RAM Trace Port	
SCR	Switch Central Resource	
SCI	Serial Communication Interface	
SECCED	Single Error Correction and Double Error Detection	
STC	Self Test Controller	
SYS	System Module	
TU	Transfer Unit	
VBUS	Virtual Bus	One of the protocols that comprises CBA (Common Bus Architecture)
VBUSP	Virtual Bus-Pipelined	One of the protocols that comprises CBA (Common Bus Architecture)
VMON	Voltage Monitor	

2.2 Device Characteristics

The table below shows the different configurations options offered in the TMS570LS series of devices:

Table 2-2. Characteristics of the TMS570LS Series Devices

Feature	TMS570LS20216		TMS570LS20206	
	337 BGA (GWT)	144 QFP (PGE)	337 BGA (GWT)	144 QFP (PGE)
Package Type	337 BGA (GWT)	144 QFP (PGE)	337 BGA (GWT)	144 QFP (PGE)
Speed	160MHz	140MHz	160MHz	140MHz
Flash Size	2MB	2MB	2MB	2MB
RAM Size	160KB	160kB	160KB	160kB
FlexRay	2ch	2ch	-	-
CAN	3	2	3	2
MibSPI	3	3	3	3
UART / LIN	2	2	2	2
NHET Channels	32	25	32	25
12-Bit ADC Channels	24	20	24	20
EMIF	16-bit	-	16-bit	-
GIO	16	8	16	8
ETM	32-bit	-	32-bit	-
RTP	16-bit	-	16-bit	-
DMM	16-bit	-	16-bit	-

2.3 Memory

2.3.1 Memory Map

The memory map, including all available Flash and RAM memory configurations for the device family, is shown below.

0xFFFFFFFF	SYSTEM Modules		
0xFFFF80000			
0xFFFF7FFFF	Peripherals		
0xFF000000			
0xFEFFFFFFF	CRC		
0xFE000000			
	RESERVED		
0x6FFFFFFF	CS3	EMIF (256MB)	0x603FFFFFF
	CS2		
	CS1		
	CS0		POM (4MB)
0x60000000	RESERVED		
0x204FFFFFF			
	Flash - ECC (2MB Mirrored Image)		0x204FFFFFF
0x20400000			
	RESERVED		
0x201FFFFFF			
	Flash (2MB) (Mirrored Image)		0x201FFFFFF
0x20000000			
	RESERVED		
0x08427FFF			
	RAM - ECC (160kB)		0x08427FFF
0x08400000			
	RESERVED		
0x08027FFF			
	RAM (160kB)		0x08027FFF
0x08000000			
	RESERVED		
0x004FFFFFF			
	Flash - ECC (2MB)		0x004FFFFFF
0x00400000			
	RESERVED		0x00400000
0x001FFFFFF			
	Flash (2MB)		0x001FFFFFF
0x00000000			

Figure 2-1. Memory Map of TMS570LS20216 and TMS570LS20206

The Parameter Overlay memory space maps to the lower 4MB of the EMIF CS0 memory space. ECC must be disabled by software via the CPU CP15 register if POM is used to overlay the program memory to the EMIF space; otherwise ECC errors will be generated. The contents of memory connected to the EMIF are not guaranteed after a power on reset. The addressable EMIF memory range is limited to the lower 32MB of each EMIF chip select for 16bit memories, and to the lower 16MB of each EMIF chip select for 8bit memories. The default EMIF data width is 16bit. The EMIF pins do not have GIO functionality.

2.3.2 Flash Memory

The F035 (130nm Flash Process) Flash memory is a nonvolatile electrically erasable and programmable memory. The Flash has a state machine for simplifying the program and erase functions.

This device's 2M-Byte flash memory contains four 512K-Byte memory arrays (or banks) consisting of 22 total sectors. 1M-Byte versions of the device contain only the first two 512K-Byte banks (Bank 0 and Bank 1) and have a total of 14 sectors. The bank and sector configurations are shown in Flash Memory Banks and Sectors . When in pipeline mode, the Flash operates with a system clock frequency of up to 160MHz (versus a system clock in non-pipeline mode of up to 36MHz). The flash in pipeline mode is capable of accessing 128 bits at a time and provides two 64-bit pipelined words to the CPU. The minimum size for an erase operation is one sector. A single program operation can program either one 32-bit word or one 16-bit half word at a time.

Table 2-3. Flash Memory Banks and Sectors

Sector NO.	Segment	Low Address	High address	MEMORY ARRAYS (OR BANKS)
Bank 0: 512K Bytes				
0	32K Bytes	0x0000_0000	0x0000_7FFF	BANK0 (512K Bytes)
1	32K Bytes	0x0000_8000	0x0000_FFFF	
2	32K Bytes	0x0001_0000	0x0001_7FFF	
3	8K Bytes	0x0001_8000	0x0001_9FFF	
4	8K Bytes	0x0001_A000	0x0001_BFFF	
5	16K Bytes	0x0001_C000	0x0001_FFFF	
6	64K Bytes	0x0002_0000	0x0002_FFFF	
7	64K Bytes	0x0003_0000	0x0003_FFFF	
8	128K Bytes	0x0004_0000	0x0005_FFFF	
9	128K Bytes	0x0006_0000	0x0007_FFFF	
Bank 1: 512K Bytes				
0	128K Bytes	0x0008_0000	0x0009_FFFF	BANK1 (512K Bytes)
1	128K Bytes	0x000A_0000	0x000B_FFFF	
2	128K Bytes	0x000C_0000	0x000D_FFFF	
3	128K Bytes	0x000E_0000	0x000F_FFFF	
Bank 2: 512K Bytes				
0	128K Bytes	0x0010_0000	0x0011_FFFF	BANK2 (512K Bytes)
1	128K Bytes	0x0012_0000	0x0013_FFFF	
2	128K Bytes	0x0014_0000	0x0015_FFFF	
3	128K Bytes	0x0016_0000	0x0017_FFFF	
Bank 3: 512K Bytes				
0	128K Bytes	0x0018_0000	0x0019_FFFF	BANK3 (512k Bytes)
1	128K Bytes	0x001A_0000	0x001B_FFFF	
2	128K Bytes	0x001C_0000	0x001D_FFFF	
3	128K Bytes	0x001E_0000	0x001F_FFFF	

NOTE

- The external flash pump voltage (VccP) is required for all flash operations (program, erase, and read). After a system reset, pipeline mode is disabled (FRDCNTL[2:0] is a "000"). In other words, the device powers up and comes out of reset in non-pipeline mode.
 - The user must program proper ECC bits throughout the entire flash memory to avoid ECC errors due to Cortex R4 speculative fetches if flash ECC is enabled.
 - The flash on this device does not support EEPROM emulation.
-

2.3.3 System Modules Assignment

This table shows the memory map for the Cyclic Redundancy Check (CRC) module, the Cortex™-R4F CoreSight™ debug module, and the System modules.

Table 2-4. System Modules Assignment

Frame Name	Address Range	
	Frame Start Address	Frame Ending Address
CRC	0xFE00_0000	0xFEFF_FFFF
CoreSight Debug ROM Register	0xFFA0_0000	0xFFA0_0FFF
Cortex-R4F Debug Register	0xFFA0_1000	0xFFA0_1FFF
ETM-R4 Register	0xFFA0_2000	0xFFA0_2FFF
CoreSight TPIU Register	0xFFA0_3000	0xFFA0_3FFF
POM Register	0xFFA0_4000	0xFFA0_4FFF
DMA RAM	0xFFF8_0000	0xFFF8_0FFF
VIM RAM	0xFFF8_2000	0xFFF8_2FFF
RTP RAM	0xFFF8_3000	0xFFF8_3FFF
Flash Wrapper Register	0xFFF8_7000	0xFFF8_7FFF
PCR Register	0xFFFF_E000	0xFFFF_E0FF
FlexRay PLL/STC CLK Register	0xFFFF_E100	0xFFFF_E1FF
PBIST Register	0xFFFF_E400	0xFFFF_E5FF
STC Register	0xFFFF_E600	0xFFFF_E6FF
EMIF Register	0xFFFF_E800	0xFFFF_E8FF
DMA Register	0xFFFF_F000	0xFFFF_F3FF
ESM Register	0xFFFF_F500	0xFFFF_F5FF
CCMR4 Register	0xFFFF_F600	0xFFFF_F6FF
DMM Register	0xFFFF_F700	0xFFFF_F7FF
RAM ECC even Register	0xFFFF_F800	0xFFFF_F8FF
RAM ECC odd Register	0xFFFF_F900	0xFFFF_F9FF
RTP Register	0xFFFF_FA00	0xFFFF_FAFF
RTI Register	0xFFFF_FC00	0xFFFF_FCFF
VIM Parity Register	0xFFFF_FD00	0xFFFF_FDFF
VIM Register	0xFFFF_FE00	0xFFFF_FEFF
System Register	0xFFFF_FF00	0xFFFF_FFFF

2.3.4 Peripheral Selects

The peripheral frame contains the memory map for the peripheral registers as well as the peripheral memories. The first table shows the memory map for the peripheral module registers and following table shows the memory map for the peripheral module memories.

Table 2-5. Peripheral Select Assignment

Peripheral Module	Address Range		Peripheral Selects
	Base Address	Ending Address	
MIBSPI5	0xFFFF7_FC00	0xFFFF7_FDFE	PS[0]
MIBSPI3	0xFFFF7_F800	0xFFFF7_F9FF	PS[1]
MIBSPI1	0xFFFF7_F400	0xFFFF7_F5FF	PS[2]
LIN2	0xFFFF7_E500	0xFFFF7_E5FF	PS[6]
LIN1	0xFFFF7_E400	0xFFFF7_E4FF	
DCAN3	0xFFFF7_E000	0xFFFF7_E1FF	PS[7]
DCAN2	0xFFFF7_DE00	0xFFFF7_DFFF	PS[8]
DCAN1	0xFFFF7_DC00	0xFFFF7_DDFF	
FlexRay	0xFFFF7_C800	0xFFFF7_CFFF	PS[12]+PS[13]
MIBADC2	0xFFFF7_C200	0xFFFF7_C3FF	PS[15]
MIBADC1	0xFFFF7_C000	0xFFFF7_C1FF	
GIO	0xFFFF7_BC00	0xFFFF7_BCFF	PS[16]
NHET	0xFFFF7_B800	0xFFFF7_B8FF	PS[17]
HET TU	0xFFFF7_A400	0xFFFF7_A4FF	PS[22]
FlexRay TU	0xFFFF7_A000	0xFFFF7_A1FF	PS[23]

Table 2-6. Peripheral Memory Selects

Peripheral Module Memory	Address Range		Peripheral Selects
	Base Address	Ending Address	
MIBSPI5 RAM	0xFF0A0000	0xFF0BFFFF	PCS[5]
MIBSPI3 RAM	0xFF0C0000	0xFF0DFFFF	PCS[6]
MIBSPI1 RAM	0xFF0E0000	0xFF0FFFFFFF	PCS[7]
DCAN3 RAM	0xFF1A0000	0xFF1BFFFF	PCS[13]
DCAN2 RAM	0xFF1C0000	0xFF1DFFFF	PCS[14]
DCAN1 RAM	0xFF1E0000	0xFF1FFFFFFF	PCS[15]
MIBADC2 RAM	0xFF3A0000	0xFF3BFFFF	PCS[29]
MIBADC1 RAM	0xFF3E0000	0xFF3FFFFFFF	PCS[31]
NHET RAM	0xFF460000	0xFF47FFFF	PCS[35]
HET TU RAM	0xFF4E0000	0xFF4FFFFFFF	PCS[39]
FlexRay TU RAM	0xFF500000	0xFF51FFFF	PCS[40]

2.3.5 Memory Auto-Initialization

This device allows some of the on-chip memories to be initialized via the memory hardware initialization control registers in the System module. The purpose of having the hardware initialization is to program the memory arrays with error detection capability to a known state based on their error detection scheme (odd/even parity or ECC). The MINITGCR register enables the memory initialization sequence, and the MSINENA register selects the memories that are to be initialized. Please refer to the Architecture chapter of the Technical Reference Manual (TRM) for more information.

The mapping of the different memories to the specific bits in the MSINENA register is shown in the following table.

Table 2-7. Memory Initialization

Connecting Module	Address Range		RAM Select
	Base Address	Ending Address	
RAM	0x08000000	0x0801FFFF	0
MIBSPI5 RAM	0xFF0A0000	0xFF0BFFFF	12
MIBSPI3 RAM	0xFF0C0000	0xFF0DFFFF	11
MIBSPI1 RAM	0xFF0E0000	0xFF0FFFFFFF	7
DCAN3 RAM	0xFF1A0000	0xFF1BFFFF	10
DCAN2 RAM	0xFF1C0000	0xFF1DFFFF	6
DCAN1 RAM	0xFF1E0000	0xFF1FFFFFFF	5
FlexRay RAM	RAM is not visible		9 ⁽¹⁾
MIBADC2 RAM	0xFF3A0000	0xFF3BFFFF	14
MIBADC1 RAM	0xFF3E0000	0xFF3FFFFFFF	8
NHET RAM	0xFF460000	0xFF47FFFF	3
HET TU RAM	0xFF4E0000	0xFF4FFFFFFF	4
DMA RAM	0xFFF80000	0xFFF80FFF	1
VIM RAM	0xFFF82000	0xFFF82FFF	2
FlexRay TU RAM	0xFF500000	0xFF51FFFF	13

(1) reserved only; the FlexRay RAM has its own Initialization mechanism.

The associated ECC RAM will get initialized as well, if the ECC functionality is enabled.

The associated Parity RAM will get initialized as well, if the Parity functionality is enabled.

NOTE

The user must initialize entire SRAM with ECC bits to avoid ECC errors due to Cortex R4 speculative fetches if SRAM ECC is enabled.

2.3.6 PBIST RAM Self Test

The PBIST (Programmable Built-In Self Test) architecture provides a run-time-programmable memory BIST engine for varying levels of test coverage across the device's embedded RAM memory. The PBIST architecture consists of a small CPU with an instruction set targeted specifically towards testing RAM memories. This CPU includes both control and instruction registers necessary to execute the individual memory algorithms. In order to minimize test load overhead, once an algorithm is loaded into the instruction registers, it can be run on multiple memories of different sizes or types. The memory configuration information and test algorithm code is stored in an on-chip ROM. The PBIST RAM groups implemented on this device are shown in the following table. More information about memory self test can be found in the PBIST chapter of the device TRM.

Table 2-8. PBIST RAM Grouping

RAM Group	Module	Memory Type	RGS /RDS ⁽¹⁾	Test Pattern (Algorithm)							
				Triple slow read [ROM clock cycles]	Triple fast read [ROM clock cycles]	March 13N [HCLK/VCLK ⁽²⁾ cycles]	Down 1A [HCLK/VCLK ⁽²⁾ cycles]	Pre-charge [HCLK/VCLK ⁽²⁾ cycles]	Map column [HCLK/VCLK ⁽²⁾ cycles]	DTXN 2A [HCLK/VCLK ⁽²⁾ cycles]	PMOS open [HCLK/VCLK ⁽²⁾ cycles]
1	PBIST ROM	ROM	0/1	12290	4098						
2	STC ROM	ROM	13/1	24578	8194						
3	DCAN1	SP	1/0..2			12600	2637	2064	1914	5490	11544
4	DCAN2	SP	2/0..2			12600	2637	2064	1914	5490	11544
5	DCAN3	SP	3/0..2			6360	1341	1104	1146	2754	5016
6	ESRAM	SP, multi-strobe w/page mode	4/21..22			266320	52254	41120	33212	181260	409616
7	MibSPI	SP	5/0..5			50160	10458	7968	6900	21924	52272
8	VIM	SP	6/0			4200	879	688	638	1830	3848
9	MibADC	2P, sync write async read	7/0..1			8400	1758	1376	1276	3660	7696
10	DMA	2P, sync write async read	8/0..5			18960	4410	3072	2772	6084	Not Available
11	NHET	2P, sync write async read	9/0..11			25440	5940	4224	4008	8136	20064
12	HET TU	2P, sync write async read	10/0..5			6480	1530	1152	1236	2052	4272
13	RTP	2P, sync write async read	11/0..8			37800	8775	6048	5310	12150	34632
14	FlexRay	SP	12/0..7			175040	34872	27296	22608	108912	246336
15	ESRAM	SP, multi-strobe w/ page mode	4/20			133160	26127	20560	16606	90630	204808

SP = Single Port RAM; 2P = Two Port RAM

(1) RGS (RAM group select) and RDS (return data select) stand for a unique RAM select id. More information about the RGS and the RDS can be found in the technical reference manual (TRM)

(2) The test clock for ESRAM, DMA and RTP is HCLK; the test clock for other modules is VCLK.

NOTE

- The March13N test algorithm is recommended for application testing.
- The maximum PBIST test execution speed is limited to 100MHz.
- The supply current while performing PBIST self test is different than the device operating mode current. These values can be found in the I_{cc} section of the device electrical specifications.

2.4 Pin Assignments

2.4.1 GWT BGA Package Pinout (337 ball)

	A	B	C	D	E	F	G	H	J	K	L	
19	VSS	VSS	TMS	NHET [10]	MIBSPI5 CS[0]	MIBSPI1 SIMO	MIBSPI1 ENA	MIBSPI5 CLK	MIBSPI5 SIMO[0]	NHET [28]	DMM DATA[0]	19
18	VSS	TCK	TDO	$\overline{\text{TRST}}$	NHET [08]	MIBSPI1 CLK	MIBSPI1 SOMI	MIBSPI5 ENA	MIBSPI5 SOMI[0]	NHET [0]	DMM DATA[1]	18
17	TDI	$\overline{\text{RST}}$	EMIF_ADDR[21]	EMIF_WE	MIBSPI5 SOM[1]	DMM CLK	MIBSPI5 SIMO[3]	MIBSPI5 SIMO[2]	NHET [31]	EMIF_CS[1]	EMIF_CS[0]	17
16	RTCK	FRAY_TXEN1	EMIF_ADDR[20]	EMIF_BA[1]	MIBSPI5 SIMO[1]	DMM ENA	MIBSPI5 SOMI[3]	MIBSPI5 SOMI[2]	DMM SYNC	EMIF_DATA[0]	EMIF_DATA[1]	16
15	FRAY_RX1	FRAY_TX1	EMIF_ADDR[19]	EMIF_ADDR[18]	ETM DATA[06]	ETM DATA[05]	ETM DATA[04]	ETM DATA[03]	ETM DATA[02]	ETM DATA[16]	ETM DATA[17]	15
14	NHET [26]	$\overline{\text{ERROR}}$	EMIF_ADDR[17]	EMIF_ADDR[16]	ETM DATA[07]	VCCIO	VCCIO	VCCIO	VCC	VCC	VCCIO	14
13	NHET [17]	NHET [19]	EMIF_ADDR[15]	EMIF_BA[0]	ETM DATA[12]	VCCIO						13
12	ECLK	NHET [04]	EMIF_ADDR[14]	EMIF_OE	ETM DATA[13]	VCCIO		VSS	VSS	VCC	VSS	12
11	NHET [14]	NHET [30]	EMIF_ADDR[13]	EMIF_DQM[1]	ETM DATA[14]	VCCIO		VSS	VSS	VSS	VSS	11
10	CAN1_TX	CAN1_RX	EMIF_ADDR[12]	EMIF_DQM[0]	ETM DATA[15]	VCC		VCC	VSS	VSS	VSS	10
	A	B	C	D	E	F	G	H	J	K	L	

Figure 2-2. GWT Package Pinout Top Left Quadrant (337 ball) [Top View]

	K	L	M	N	P	R	T	U	V	W	
19	NHET [28]	DMM DATA[0]	CAN3 RX	AD1 EVT	ADS IN[15]	AD2 IN[6]	AD1 IN[6]	ADS IN[11]	VSSAD	VSSAD	19
18	NHET [0]	DMM DATA[1]	CAN3 TX	NC	ADS IN[8]	ADS IN[14]	ADS IN[13]	AD1 IN[4]	AD1 IN[2]	VSSAD	18
17	EMIF_CS[1]	EMIF_CS[0]	EMIF_CS[2]	EMIF_CS[3]	NC	AD1 IN[5]	AD1 IN[3]	ADS IN[10]	AD1 IN[1]	ADS IN[9]	17
16	EMIF_DATA[0]	EMIF_DATA[1]	EMIF_DATA[2]	EMIF_DATA[3]	NC	AD2 IN[7]	ADS IN[12]	AD2 IN[3]	ADREF LO	VSSAD	16
15	ETM DATA[16]	ETM DATA [17]	ETM DATA[18]	ETM DATA[19]	NC	NC	AD2 IN[5]	AD2 IN[4]	ADREF HI	VCCAD	15
14	VCC	VCCIO	VCCIO	VCCIO	VCCIO	NC	NC	AD2 IN[2]	AD1 IN[7]	AD1 IN[0]	14
13					VCCIO	ETM DATA[1]	NC	AD2 IN[1]	AD2 IN[0]	AD2 EVT	13
12	VCC	VSS	VSS		VCCIO	ETM DATA[0]	MIBSPI5 CS[3]	RTP ENA	LIN1 TX	LIN1 RX	12
11	VSS	VSS	VSS		VCC	ETM TRACE CTL	RTP SYNC	RTP DATA[1]	RTP DATA[0]	RTP CLK	11
10	VSS	VSS	VCC		VCC	ETM TRACE CLKOUT	RTP DATA[2]	RTP DATA[3]	MIBSPI3 CS[0]	GIOB[3]	10
	K	L	M	N	P	R	T	U	V	W	

Figure 2-3. GWT Package Pinout Top Right Quadrant (337 ball) [Top View]

	A	B	C	D	E	F	G	H	J	K	L	
10	CAN1TX	CAN1RX	EMIF_ADDR[12]	EMIF_DQM[0]	ETM_DATA[15]	VCC		VCC	VSS	VSS	VSS	10
9	NHET [27]	FRAY_TXEN2	EMIF_ADDR[11]	EMIF_ADDR[5]	ETM_DATA[8]	VCC		VSS	VSS	VSS	VSS	9
8	FRAY_RX2	FRAY_TX2	EMIF_ADDR[10]	EMIF_ADDR[4]	ETM_DATA[9]	VCCP		VSS	VSS	VCC	VSS	8
7	LIN2_RX	LIN2_TX	EMIF_ADDR[9]	EMIF_ADDR[3]	ETM_DATA[10]	VCCIO						7
6	GIOA [4]	MIBSPI5_CS[1]	EMIF_ADDR[8]	EMIF_ADDR[2]	ETM_DATA[11]	VCCIO	VCCIO	VCCIO	VCCIO	VCC	VCC	6
5	GIOA [0]	GIOA [5]	EMIF_ADDR[7]	EMIF_ADDR[1]	ETM_DATA[20]	ETM_DATA[21]	ETM_DATA[22]	FLTP2	FLTP1	ETM_DATA[23]	ETM_DATA[24]	5
4	NHET [16]	NHET [12]	EMIF_ADDR[6]	EMIF_ADDR[0]	EMIF_DATA[4]	EMIF_DATA[5]	EMIF_DATA[6]	NHET [21]	NHET [23]	EMIF_DATA[7]	EMIF_DATA[8]	4
3	NHET [29]	NHET [22]	MIBSPI3_CS[3]	NC	NHET [11]	MIBSPI1_CS[1]	MIBSPI1_CS[2]	GIOA [6]	MIBSPI1_CS[3]	NC	NC	3
2	VSS	MIBSPI3_CS[2]	GIOA [1]	NC	NC	GIOB [2]	GIOB [5]	CAN2_TX	GIOB [6]	GIOB [1]	KELVIN_GND	2
1	VSS	VSS	GIOA [2]	NC	GIOA [3]	GIOB [7]	GIOB [4]	CAN2_RX	NHET [18]	OSCIN	OSCOUT	1
	A	B	C	D	E	F	G	H	J	K	L	

Figure 2-4. GWT Package Pinout Bottom Left Quadrant (337 ball) [Top View]

	K	L	M	N	P	R	T	U	V	W	
10	VSS	VSS	VCC		VCC	ETM TRACE CLKOUT	RTP DATA[2]	RTP DATA[3]	MIBSPI3 CS[0]	GIOB[3]	10
9	VSS	VSS	VSS		VCCIO	ETM TRACE CLKIN	RTP DATA[4]	RTP DATA[5]	MIBSPI3 CLK	MIBSPI3 ENA	9
8	VCC	VSS	VSS		VCCIO	ETM DATA[31]	EMIF_DATA[15]	RTP DATA[6]	MIBSPI3 SOMI	MIBSPI3 SIMO	8
7					VCCIO	ETM DATA[30]	EMIF_DATA[14]	RTP DATA[7]	NHET [9]	$\overline{\text{PORRST}}$	7
6	VCC	VCC	VCCIO	VCCIO	VCCIO	ETM DATA[29]	EMIF_DATA[13]	RTP DATA[8]	NHET [5]	MIBSPI5 CS[2]	6
5	ETM DATA[23]	ETM DATA[24]	ETM DATA[25]	ETM DATA[26]	ETM DATA[27]	ETM DATA[28]	EMIF_DATA[12]	RTP DATA[9]	MIBSPI3 CS[1]	NHET [2]	5
4	EMIF_DATA[7]	EMIF_DATA[8]	EMIF_DATA[9]	EMIF_DATA[10]	EMIF_DATA[11]	NC	RTP DATA[11]	RTP DATA[10]	VSS	NC	4
3	NC	NC	NHET [25]	NC	NC	NC	RTP DATA[14]	RTP DATA[13]	RTP DATA[12]	NHET [6]	3
2	GIOB [1]	KELVIN GND	GIOB [0]	NHET [13]	NHET [20]	MIBSPI1 CS[0]	RTP DATA[15]	TEST	NHET [1]	VSS	2
1	OSCIN	OSCOUT	GIOA [7]	NHET [15]	NHET [24]	NC	NHET [7]	NHET [3]	VSS	VSS	1
	K	L	M	N	P	R	T	U	V	W	

Figure 2-5. GWT Package Pinout Bottom Right Quadrant (337 ball) [Top View]

2.4.2 PGE QFP Package Pinout (144 pin)

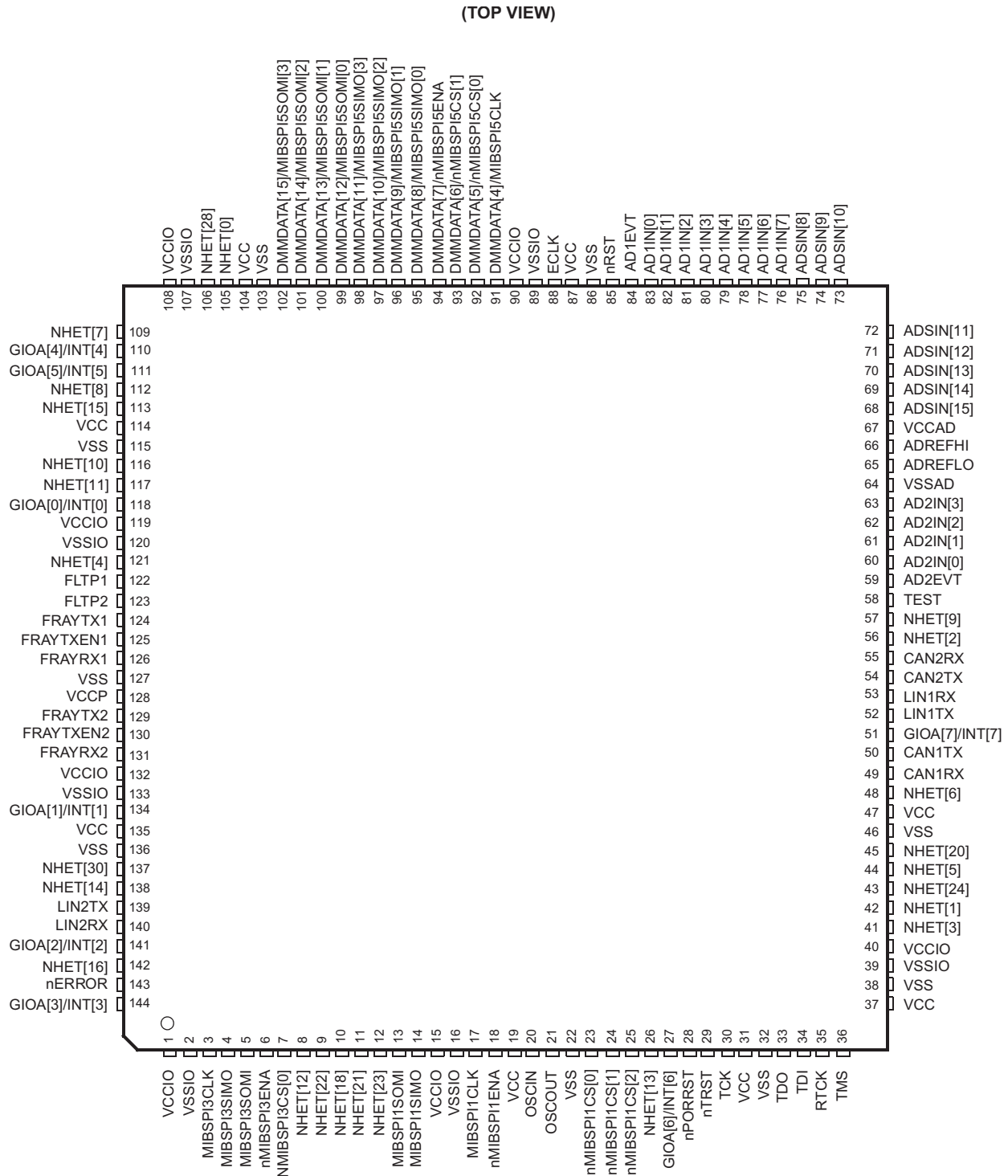

Figure 2-6. PGE Pinout (144 pin) [Top View]

2.5 Terminal Functions

This following table describes the pins on the device.

NOTE

Table Abbreviations: PWR = power, GND = ground, REF = reference voltage, NC = no connect, IPD = Internal Pull Down, IPU = Internal Pull Up, I/O = Input/Output, I = Input, O = Output

Table 2-9. Terminal Functions

Name	Terminal				Type	Internal pullup/pulldown	Description
	TMS570LS20216		TMS570LS20206				
	337	144	337	144			
HIGH-END TIMER (NHET)							
NHET[0]	K18	105	K18	105	3.3V I/O	2mA - z	Timer input capture or output compare. The applicable NHET pins can be programmed as general-purpose input/output (GIO) pins. NHET pins are high-resolution. The high-resolution (HR) SHARE feature allows even HR pins to share the next higher odd HR pin structures. The next higher odd HR pin structure is always implemented, even if the next higher odd HR pad and/or pin itself is not. The HR sharing is independent of whether or not the odd pin is available externally. If an odd pin is available externally and shared, then the odd pin can only be used as a general-purpose I/O. NHET[0] provides SPI clock when used for SPI emulation. Each NHET pin is equipped with an input suppression filter that can be used to eliminate the sampling of pulses that are smaller than a programmable duration GIOA[0]/INT[0] is also connected to the NHET Pin Disable input of the NHET module. NHET pins can be programmed as a GIO pins when not used as NHET functional pins.
NHET[1]	V2	42	V2	42			
NHET[2]	W5	56	W5	56			
NHET[3]	U1	41	U1	41			
NHET[4]	B12	121	B12	121			
NHET[5]	V6	44	V6	44			
NHET[6]	W3	48	W3	48			
NHET[7]	T1	109	T1	109			
NHET[8]	E18	112	E18	112			
NHET[9]	V7	57	V7	57			
NHET[10]	D19	116	D19	116			
NHET[11]	E3	117	E3	117			
NHET[12]	B4	8	B4	8			
NHET[13]	N2	26	N2	26			
NHET[14]	A11	138	A11	138			
NHET[15]	N1	113	N1	113			
NHET[16]	A4	142	A4	142			
NHET[17]	A13		A13				
NHET[18]	J1	10	J1	10			
NHET[19]	B13		B13				
NHET[20]	P2	45	P2	45			
NHET[21]	H4	11	H4	11			
NHET[22]	B3	9	B3	9			
NHET[23]	J4	12	J4	12			
NHET[24]	P1	43	P1	43			
NHET[25]	M3		M3				
NHET[26]	A14		A14				
NHET[27]	A9		A9				
NHET[28]	K19	106	K19	106			
NHET[29]	A3		A3				
NHET[30]	B11	137	B11	137			
NHET[31]	J17		J17				

Table 2-9. Terminal Functions (continued)

Name	Terminal				Type	Internal pullup/pulldown	Description		
	TMS570LS20216		TMS570LS20206						
	337	144	337	144					
GENERAL-PURPOSE I/O (GIO)									
GIOA[0]/INT0	A5	118	A5	118	3.3V I/O	2mA - z	Program mable IPD (20uA)	General-purpose input/output pin. GIOA[0]/INT[0] is an interrupt-capable pin. GIOA[0]/INT[0] is also connected to the NHET Pin Disable input of the NHET module.	
GIOA[1]/INT1	C2	134	C2	134				General-purpose input/output pins. GIOA[7:1]/INT[7:1] are interrupt-capable pins.	
GIOA[2]/INT2	C1	141	C1	141					
GIOA[3]/INT3	E1	144	E1	144					
GIOA[4]/INT4	A6	110	A6	110					
GIOA[5]/INT5	B5	111	B5	111					
GIOA[6]/INT6	H3	27	H3	27					
GIOA[7]/INT7	M1	51	M1	51					
GIOB[0]	M2		M2						General-purpose input/output pins.
GIOB[1]	K2		K2						
GIOB[2]	F2		F2						
GIOB[3]	W10		W10						
GIOB[4]	G1		G1						
GIOB[5]	G2		G2						
GIOB[6]	J2		J2						
GIOB[7]	F1		F1						
FlexRay Controller (FLEXRAY)									
NOTE: Devices with out the FlexRay option should leave all FlexRay pins unconnected (NC)									
FRAYRX1	A15	126			3.3V I		Program mable IPD (20uA)	FlexRay data receive (channel 1) pin	
FRAYTX1	B15	124			3.3V O	8mA		FlexRay data transmit (channel 1) pin	
FRAYTXEN1	B16	125				8mA		FlexRay transmit enable (channel 1) pin	
FRAYRX2	A8	131			3.3V I		Program mable IPD(20uA)	FlexRay data receive (channel 2) pin	
FRAYTX2	B8	129			3.3V O	8mA		FlexRay data transmit (channel 2) pin	
FRAYTXEN2	B9	130				8mA		FlexRay transmit enable (channel 2) pin	
CAN Controller (DCAN1)									
CAN1TX	A10	50	A10	50	3.3V I/O	2mA - z	Program mable IPU (20uA)	CAN1 transmit pin or GIO pin	
CAN1RX	B10	49	B10	49				CAN1 receive pin or GIO pin	
CAN Controller (DCAN2)									
CAN2TX	H2	54	H2	54	3.3V I/O	2mA - z	Program mable IPU (20uA)	CAN2 transmit pin or GIO pin	
CAN2RX	H1	55	H1	55				CAN2 receive pin or GIO pin	
CAN Controller (DCAN3)									
CAN3TX	M18		M18		3.3V I/O	2mA - z	program mable IPU (20uA)	CAN3 transmit pin or GIO pin	
CAN3RX	M19		M19					CAN3 receive pin or GIO pin	

Table 2-9. Terminal Functions (continued)

Name	Terminal				Type	Internal pullup/pulldown	Description	
	TMS570LS20216		TMS570LS20206					
	337	144	337	144				
Serial Communications Interface (SCI)/Local Interconnect Network (LIN1)								
LIN1RX	W12	53	W12	53	3.3V I/O	2mA - z	Program mable IPU (20uA)	LIN1 data receive pin or GIO pin
LIN1TX	V12	52	V12	52				LIN1 data transmit pin or GIO pin
Serial Communications Interface (SCI)/Local Interconnect Network (LIN2)								
LIN2RX	A7	140	A7	140	3.3V I/O	2mA - z	Program mable IPU (20uA)	LIN2 data receive pin or GIO pin
LIN2TX	B7	139	B7	139				LIN2 data transmit pin or GIO pin
Multibuffered Serial Peripheral Interface (MIBSPI1)								
MIBSPI1CLK	F18	17	F18	17	3.3V I/O	4mA	Program mable IPU (20uA)	MIBSPI1 clock pin or GIO pin
MIBSPI1CS[0]	R2	23	R2	23		2mA - z		MIBSPI1 slave chip select pins or GIO pins
MIBSPI1CS[1]	F3	24	F3	24				
MIBSPI1CS[2]	G3	25	G3	25				
MIBSPI1CS[3]	J3		J3			2mA - z		MIBSPI1 enable pin or GIO pin
MIBSPI1EN \bar{A}	G19	18	G19	18				
MIBSPI1SIMO	F19	14	F19	14		4mA		MIBSPI1 data stream - Slave in/master out pin or GIO pin
MIBSPI1SOMI	G18	13	G18	13				MIBSPI1 data stream - Slave out/master in pin or GIO pin
Multibuffered Serial Peripheral Interface (MIBSPI3)								
MIBSPI3CLK	V9	3	V9	3	3.3V I/O	4mA	Program mable IPU (20uA)	MIBSPI3 clock pin or GIO pin
MIBSPI3CS[0]	V10	7	V10	7		2mA - z		MIBSPI3 slave chip select pins or GIO pins
MIBSPI3CS[1]	V5		V5					
MIBSPI3CS[2]	B2		B2					
MIBSPI3CS[3]	C3		C3			2mA - z		MIBSPI3 enable pin or GIO pin
MIBSPI3EN \bar{A}	W9	6	W9	6				
MIBSPI3SIMO	W8	4	W8	4		4mA		MIBSPI3 data stream - Slave in/master out pin or GIO pin
MIBSPI3SOMI	V8	5	V8	5				MIBSPI3 data stream - Slave out/master in pin or GIO pin

Table 2-9. Terminal Functions (continued)

Name	Terminal				Type	Internal pullup/pulldown	Description	
	TMS570LS20216		TMS570LS20206					
	337	144	337	144				
Multibuffered Serial Peripheral Interface - Parallel (MIBSPI5)								
MIBSPI5CLK/DMMDATA[4]	H19	91	H19	91	3.3V I/O	4mA	MIBSPI5 clock pin or GIO pin; multiplexed with DMMDATA[4] pin	
MIBSPI5CS[0]/DMMDATA[5]	E19	92	E19	92		2mA - z	Program mable IPU (20uA)	MIBSPI5 slave chip select pins or GIO pins; multiplexed with DMMDATA pins
MIBSPI5CS[1]/DMMDATA[6]	B6	93	B6	93				
MIBSPI5CS[2]/DMMDATA[2]	W6		W6					
MIBSPI5CS[3]/DMMDATA[3]	T12		T12					
MIBSPI5ENA/DMMDATA[7]	H18	94	H18	94				
MIBSPI5SIMO[0]/DMMDATA[8]	J19	95	J19	95	4mA		MIBSPI5 data stream - Slave in/master out pins or GIO pins; multiplexed with DMMDATA pins	
DMMDATA[9]/MIBSPI5SIMO[1]	E16	96	E16	96				
MIBSPI5SIMO[2]/DMMDATA[10]	H17	97	H17	97				
MIBSPI5SIMO[3]/DMMDATA[11]	G17	98	G17	98				
MIBSPI5SOMI[0]/DMMDATA[12]	J18	99	J18	99				
MIBSPI5SOMI[1]/DMMDATA[13]	E17	100	E17	100				
MIBSPI5SOMI[2]/DMMDATA[14]	H16	101	H16	101			MIBSPI5 data stream - Slave out/master in pins or GIO pins; multiplexed with DMMDATA pins	
MIBSPI5SOMI[3]/DMMDATA[15]	G16	102	G16	102				
Multibuffered Analog-To-Digital Converter (MIBADC1)								
AD1EVT	N19	84	N19	84	3.3V I/O	2 mA - z	Program mable IPD (20uA)	MibADC1 event input pin or GIO pin
AD1IN[0]	W14	83	W14	83	3.3V I			MibADC1 analog input pins
AD1IN[1]	V17	82	V17	82				
AD1IN[2]	V18	81	V18	81				
AD1IN[3]	T17	80	T17	80				
AD1IN[4]	U18	79	U18	79				
AD1IN[5]	R17	78	R17	78				
AD1IN[6]	T19	77	T19	77				
AD1IN[7]	V14	76	V14	76				

Table 2-9. Terminal Functions (continued)

Name	Terminal				Type	Internal pullup/pulldown	Description	
	TMS570LS20216		TMS570LS20206					
	337	144	337	144				
Multibuffered Analog-To-Digital Converter (MIBADC2)								
AD2EVT	W13	59	W13	59	3.3V I/O	2 mA - z	Program mable I _{PD} (20uA)	MibADC2 event input pin or GIO pin
AD2IN[0]	V13	60	V13	60	3.3 V I			MibADC2 analog input pins
AD2IN[1]	U13	61	U13	61				
AD2IN[2]	U14	62	U14	62				
AD2IN[3]	U16	63	U16	63				
AD2IN[4]	U15		U15					
AD2IN[5]	T15		T15					
AD2IN[6]	R19		R19					
AD2IN[7]	R16		R16					
Multibuffered Analog-To-Digital Converter - shared signals (MIBADC1, MIBADC2)								
ADSIN[8]	P18	75	P18	75	3.3 V I			MibADC1, MibADC2 shared analog input pins
ADSIN[9]	W17	74	W17	74				
ADSIN[10]	U17	73	U17	73				
ADSIN[11]	U19	72	U19	72				
ADSIN[12]	T16	71	T16	71				
ADSIN[13]	T18	70	T18	70				
ADSIN[14]	R18	69	R18	69				
ADSIN[15]	P19	68	P19	68				
ADREFHI	V15	66	V15	66	3.3-V REF			MibADC1, MibADC2 module high-voltage reference input
ADREFLO	V16	65	V16	65	GND REF			MibADC1, MibADC2 module low-voltage reference input
VCCAD	W15	67	W15	67	3.3-V PWR			MibADC1, MibADC2 analog supply voltage
VSSAD	V19	64	V19	64	GND			MibADC1, MibADC2 analog ground reference
VSSAD	W16		W16					
VSSAD	W18		W18					
VSSAD	W19		W19					
Oscillator (OSC)								
OSCIN	K1	20	K1	20	1.5V I			Oscillator input connection pin or external clock input pin
OSCOUT	L1	21	L1	21	1.5V O			Oscillator output connection pin
Kelvin_GND	L2		L2		GND			Kelvin_GND for oscillator

Table 2-9. Terminal Functions (continued)

Name	Terminal				Type	Internal pullup/pulldown	Description	
	TMS570LS20216		TMS570LS20206					
	337	144	337	144				
System Module (SYS)								
$\overline{\text{PORRST}}$	W7	28	W7	28	3.3V I		IPD (100 μ A) Power on Reset Pin. External power supply monitor circuitry must assert a power-on reset on this pin.	
$\overline{\text{RST}}$	B17	85	B17	85	3.3V I/O	4mA	IPU (100 μ A) Active Low Bidirectional Reset pin. An external device can assert a device reset on this pin. The output buffer on this pin is implemented as an open drain (drives low only). To ensure an external reset is not arbitrarily generated, TI recommends that an external pullup resistor is connected to this pin.	
ECLK	A12	88	A12	88		8mA	IPD (20 μ A) External Clock Prescaler module output pin or GIO pin	
Tset/Debug (T/D)								
TCK	B18	30	B18	30	3.3V I		IPD (100 μ A) JTAG test clock pin. Clocks the JTAG debug logic.	
RTCK	A16	35	A16	35	3.3V O		IPD (100 μ A) JTAG return test clock pin. (JTAG)	
TDI	A17	34	A17	34	3.3V I/O	8 mA	IPU (100 μ A) JTAG test data in pin.	
TDO	C18	33	C18	33			IPD (100 μ A) JTAG test data out pin.	
TMS	C19	36	C19	36			IPU (100 μ A) JTAG serial input pin for controlling the state of the CPU test access port (TAP) controller.	
$\overline{\text{TRST}}$	D18	29	D18	29			IPD (100 μ A) JTAG test hardware reset to TAP. IEEE Standard 1149-1 (JTAG) Boundary-Scan Logic	
TEST	U2	58	U2	58	3.3V I		IPD (100 μ A) Test enable pin. Reserved for internal TI use only. For proper operation, this pin must be connected to ground, e.g. using an external resistor.	
Error Signaling Module (ESM)								
$\overline{\text{ERROR}}$	B14	143	B14	143	3.3V I/O	8mA	IPD (20 μ A) Error Signaling pin	
Flash								
FLTP1	J5	122	J5	122				Flash Test Pad 1 pin. For proper operation this pin must connect only to a test pad or not be connected at all [no connect (NC)]. The test pad must not be exposed in the final product where it might be subjected to an ESD event.
FLTP2	H5	123	H5	123				Flash Test Pad 2 pin. For proper operation this pin must connect only to a test pad or not be connected at all [no connect (NC)]. The test pad must not be exposed in the final product where it might be subjected to an ESD event.
V _{CCP}	F8	128	F8	128	3.3V PWR			Flash pump voltage supply (3.3 V). This pin is required for Flash read, program and erase operations.

Table 2-9. Terminal Functions (continued)

Terminal		TMS570LS20216		TMS570LS20206		Type	Internal pullup/pulldown	Description
RAM Trace Port Module (RTP)								
RTPDATA[0]	V11		V11		3.3V I/O	8mA	Program mable IPU (20uA)	RAM Trace Port Output Data Signal pins or GIO pins
RTPDATA[1]	U11		U11					
RTPDATA[2]	T10		T10					
RTPDATA[3]	U10		U10					
RTPDATA[4]	T9		T9					
RTPDATA[5]	U9		U9					
RTPDATA[6]	U8		U8					
RTPDATA[7]	U7		U7					
RTPDATA[8]	U6		U6					
RTPDATA[9]	U5		U5					
RTPDATA[10]	U4		U4					
RTPDATA[11]	T4		T4					
RTPDATA[12]	V3		V3					
RTPDATA[13]	U3		U3					
RTPDATA[14]	T3		T3					
RTPDATA[15]	T2		T2					
$\overline{\text{RTPEN}}_A$	U12		U12			2mA - z		Packet Handshake Signal pin or GIO pin
RTPSYNC	T11		T11			8mA		Packet Synchronization Signal pin or GIO pin
RTPCLK	W11		W11					Packet Clock Signal pin or GIO pin

Table 2-9. Terminal Functions (continued)

Terminal				Type	Internal pullup/pulldown	Description	
Name	TMS570LS20216		TMS570LS20206				
	337	144	337				144
Data Modification Module (DMM)							
DMMDATA[0]	L19		L19		3.3V I/O	DMM Data pins or GIO pins	
DMMDATA[1]	L18		L18				
DMMDATA[2]/MIBSPI5CS[2]	W6		W6	2mA - z			
DMMDATA[3]/MIBSPI5CS[3]	T12		T12				
DMMDATA[4]/MIBSPI5CLK	H19		H19	4mA			
DMMDATA[5]/MIBSPI5CS[0]	E19		E19				
DMMDATA[6]/MIBSPI5CS[1]	B6		B6	2mA - z			
DMMDATA[7]/MIBSPI5ENA	H18		H18				
DMMDATA[8]/MIBSPI5SIMO[0]	J19		J19				
DMMDATA[9]/MIBSPI5SIMO[1]	E16		E16				
DMMDATA[10]/MIBSPI5SIMO[2]	H17		H17				
DMMDATA[11]/MIBSPI5SIMO[3]	G17		G17	4mA			
DMMDATA[12]/MIBSPI5SOMI[0]	J18		J18				
DMMDATA[13]/MIBSPI5SOMI[1]	E17		E17				
DMMDATA[14]/MIBSPI5SOMI[2]	H16		H16				
DMMDATA[15]/MIBSPI5SOMI[3]	G16		G16				
DMMENA	F16		F16	8mA	DMM Handshake pin or GIO pin		
DMMSYNC	J16		J16		DMM Synchronization pin or GIO pin		
DMMCLK	F17		F17	2mA - z	DMM Clock input pin or GIO pin		

Table 2-9. Terminal Functions (continued)

Name	Terminal				Type	Internal pullup/pulldown	Description
	TMS570LS20216		TMS570LS20206				
	337	144	337	144			
External Memory Interface Module (EMIF)							
EMIFBADD[0]	D13		D13		3.3V I/O	8mA	EMIF Byte Address pins
EMIFBADD[1]	D16		D16				
EMIFDATA[0]	K16		K16				
EMIFDATA[1]	L16		L16		3.3V I/O	8mA	Program mable IPU (20uA) EMIF Data pins
EMIFDATA[2]	M16		M16				
EMIFDATA[3]	N16		N16				
EMIFDATA[4]	E4		E4				
EMIFDATA[5]	F4		F4				
EMIFDATA[6]	G4		G4				
EMIFDATA[7]	K4		K4				
EMIFDATA[8]	L4		L4				
EMIFDATA[9]	M4		M4				
EMIFDATA[10]	N4		N4				
EMIFDATA[11]	P4		P4				
EMIFDATA[12]	T5		T5				
EMIFDATA[13]	T6		T6				
EMIFDATA[14]	T7		T7				
EMIFDATA[15]	T8		T8				
EMIFADD[0]	D4		D4		3.3V I/O	8mA	EMIF Address pins
EMIFADD[1]	D5		D5				
EMIFADD[2]	D6		D6				
EMIFADD[3]	D7		D7				
EMIFADD[4]	D8		D8				
EMIFADD[5]	D9		D9				
EMIFADD[6]	C4		C4				
EMIFADD[7]	C5		C5				
EMIFADD[8]	C6		C6				
EMIFADD[9]	C7		C7				
EMIFADD[10]	C8		C8				
EMIFADD[11]	C9		C9				
EMIFADD[12]	C10		C10				
EMIFADD[13]	C11		C11				
EMIFADD[14]	C12		C12				
EMIFADD[15]	C13		C13				
EMIFADD[16]	D14		D14				
EMIFADD[17]	C14		C14				
EMIFADD[18]	D15		D15				
EMIFADD[19]	C15		C15				
EMIFADD[20]	C16		C16				
EMIFADD[21]	C17		C17				
EMIFCS[0]	L17		L17		3.3V I/O	8mA	EMIF Chip Select pins
EMIFCS[1]	K17		K17				
EMIFCS[2]	M17		M17				
EMIFCS[3]	N17		N17				

Table 2-9. Terminal Functions (continued)

Name	Terminal				Type		Internal pullup/pulldown	Description
	TMS570LS20216		TMS570LS20206					
	337	144	337	144				
EMIFWE	D17		D17		3.3V I/O	8mA		EMIF Write Enable pin
EMIFOE	D12		D12		3.3V I/O	8mA		EMIF Output Enable pin
EMIFDQM[0]	D10		D10		3.3V I/O	8mA		EMIF Byte Enable pins
EMIFDQM[1]	D11		D11					

Table 2-9. Terminal Functions (continued)

Name	Terminal				Type	Internal pullup/pulldown	Description
	TMS570LS20216		TMS570LS20206				
	337	144	337	144			
Embedded Trace Module (ETM)							
ETMDATA[0]	R12		R12		3.3V O	8mA	ETM Trace Data output pins
ETMDATA[1]	R13		R13				
ETMDATA[2]	J15		J15				
ETMDATA[3]	H15		H15				
ETMDATA[4]	G15		G15				
ETMDATA[5]	F15		F15				
ETMDATA[6]	E15		E15				
ETMDATA[7]	E14		E14				
ETMDATA[8]	E9		E9				
ETMDATA[9]	E8		E8				
ETMDATA[10]	E7		E7				
ETMDATA[11]	E6		E6				
ETMDATA[12]	E13		E13				
ETMDATA[13]	E12		E12				
ETMDATA[14]	E11		E11				
ETMDATA[15]	E10		E10				
ETMDATA[16]	K15		K15				
ETMDATA[17]	L15		L15				
ETMDATA[18]	M15		M15				
ETMDATA[19]	N15		N15				
ETMDATA[20]	E5		E5				
ETMDATA[21]	F5		F5				
ETMDATA[22]	G5		G5				
ETMDATA[23]	K5		K5				
ETMDATA[24]	L5		L5				
ETMDATA[25]	M5		M5				
ETMDATA[26]	N5		N5				
ETMDATA[27]	P5		P5				
ETMDATA[28]	R5		R5				
ETMDATA[29]	R6		R6				
ETMDATA[30]	R7		R7				
ETMDATA[31]	R8		R8				
ETMTRACECTL	R11		R11				ETM Control pin
ETMTRACECLKOUT	R10		R10		3.3V O	8mA	ETM Clock output pin
ETMTRACECLKIN	R9		R9		3.3V I		IPU (20uA) ETM Clock input pin

Table 2-9. Terminal Functions (continued)

Name	Terminal				Type	Internal pullup/pulldown	Description
	TMS570LS20216		TMS570LS20206				
	337	144	337	144			
Supply Voltage Digital I/O (3.3V) and Core (1.5V)							
V _{CCIO}	F6	1	F6	1	3.3V PWR		Digital I/O supply pins Note: All V _{CCIO} pads are connected to the BGA packages through the package substrate. There is not a direct ball to bond pad connection for this supply.
V _{CCIO}	F7	15	F7	15			
V _{CCIO}	F11	40	F11	40			
V _{CCIO}	F12	90	F12	90			
V _{CCIO}	F13	108	F13	108			
V _{CCIO}	F14	119	F14	119			
V _{CCIO}	G6	132	G6	132			
V _{CCIO}	G14		G14				
V _{CCIO}	H6		H6				
V _{CCIO}	H14		H14				
V _{CCIO}	J6		J6				
V _{CCIO}	L14		L14				
V _{CCIO}	M6		M6				
V _{CCIO}	M14		M14				
V _{CCIO}	N6		N6				
V _{CCIO}	N14		N14				
V _{CCIO}	P6		P6				
V _{CCIO}	P7		P7				
V _{CCIO}	P8		P8				
V _{CCIO}	P9		P9				
V _{CCIO}	P12		P12				
V _{CCIO}	P13		P13				
V _{CCIO}	P14		P14				
V _{CCIO}							
V _{CC}	F9	19	F9	19	1.5V PWR		Digital Core supply pins Note: All V _{CC} pads are connected to the BGA packages through the package substrate. There is not a direct ball to bond pad connection for this supply.
V _{CC}	F10	31	F10	31			
V _{CC}	H10	37	H10	37			
V _{CC}	J14	47	J14	47			
V _{CC}	K6	87	K6	87			
V _{CC}	K8	104	K8	104			
V _{CC}	K12	114	K12	114			
V _{CC}	K14	135	K14	135			
V _{CC}	L6		L6				
V _{CC}	M10		M10				
V _{CC}	P10		P10				
V _{CC}	P11		P11				
V _{CC}							

Table 2-9. Terminal Functions (continued)

Name	Terminal				Type	Internal pullup/pulldown	Description
	TMS570LS20216		TMS570LS20206				
	337	144	337	144			
Supply Ground							
V _{SS}	A1	2	A1	2	GND		Digital supply ground reference pins Note: All V _{SS} pads are connected to the BGA packages through the package substrate.
V _{SS}	A2	16	A2	16			
V _{SS}	A18	22	A18	22			
V _{SS}	A19	32	A19	32			
V _{SS}	B1	38	B1	38			
V _{SS}	B19	39	B19	39			
V _{SS}	H8	46	H8	46			
V _{SS}	H9	86	H9	86			
V _{SS}	H11	89	H11	89			
V _{SS}	H12	103	H12	103			
V _{SS}	J8	107	J8	107			
V _{SS}	J9	115	J9	115			
V _{SS}	J10	120	J10	120			
V _{SS}	J11	127	J11	127			
V _{SS}	J12	133	J12	133			
V _{SS}	K9	136	K9	136			
V _{SS}	K10		K10				
V _{SS}	K11		K11				
V _{SS}	L8		L8				
V _{SS}	L9		L9				
V _{SS}	L10		L10				
V _{SS}	L11		L11				
V _{SS}	L12		L12				
V _{SS}	M8		M8				
V _{SS}	M9		M9				
V _{SS}	M11		M11				
V _{SS}	M12		M12				
V _{SS}	V1		V1				
V _{SS}	W1		W1				
V _{SS}	W2		W2				
V _{SS}	V4		V4				
V _{SS}							
V _{SS}							
V _{SS}							
V _{SS}							
V _{SS}							

2.6 Device Support

2.6.1 Device and Development-Support Tool Nomenclature

To designate the stages in the product development cycle, TI assigns prefixes to the part numbers of all devices and support tools. Each commercial family member has one of three prefixes: TMX, TMP, or TMS (e.g., TMS570LS20216ASGWTMEP). Texas Instruments recommends two of three possible prefix designators for its support tools: TMDX and TMDS. These prefixes represent evolutionary stages of product development from engineering prototypes (TMX/TMDX) through fully qualified production devices/tools (TMS/TMDS).

Device development evolutionary flow:

- TMX** Experimental device that is not necessarily representative of the final device's electrical specifications.
- TMP** Final silicon die that conforms to the device's electrical specifications but has not completed quality and reliability verification.
- TMS** Fully-qualified production device.

Support tool development evolutionary flow:

- TMDX** Development-support product that has not yet completed Texas Instruments internal qualification testing.
- TMDS** Fully qualified development-support product.

TMX and TMP devices and TMDX development-support tools are shipped against the following disclaimer:

"Developmental product is intended for internal evaluation purposes."

TMS devices and TMDS development-support tools have been characterized fully, and the quality and reliability of the device have been demonstrated fully. TI's standard warranty applies.

Predictions show that prototype devices (TMX or TMP) have a greater failure rate than the standard production devices. Texas Instruments recommends that these devices not be used in any production system because their expected end-use failure rate still is undefined. Only qualified production devices are to be used.

TI device nomenclature also includes a suffix with the device family name. This suffix indicates the package type (for example, GWT), the temperature range (for example, "Blank" is the commercial temperature range), and the device speed range in Mega Hertz.

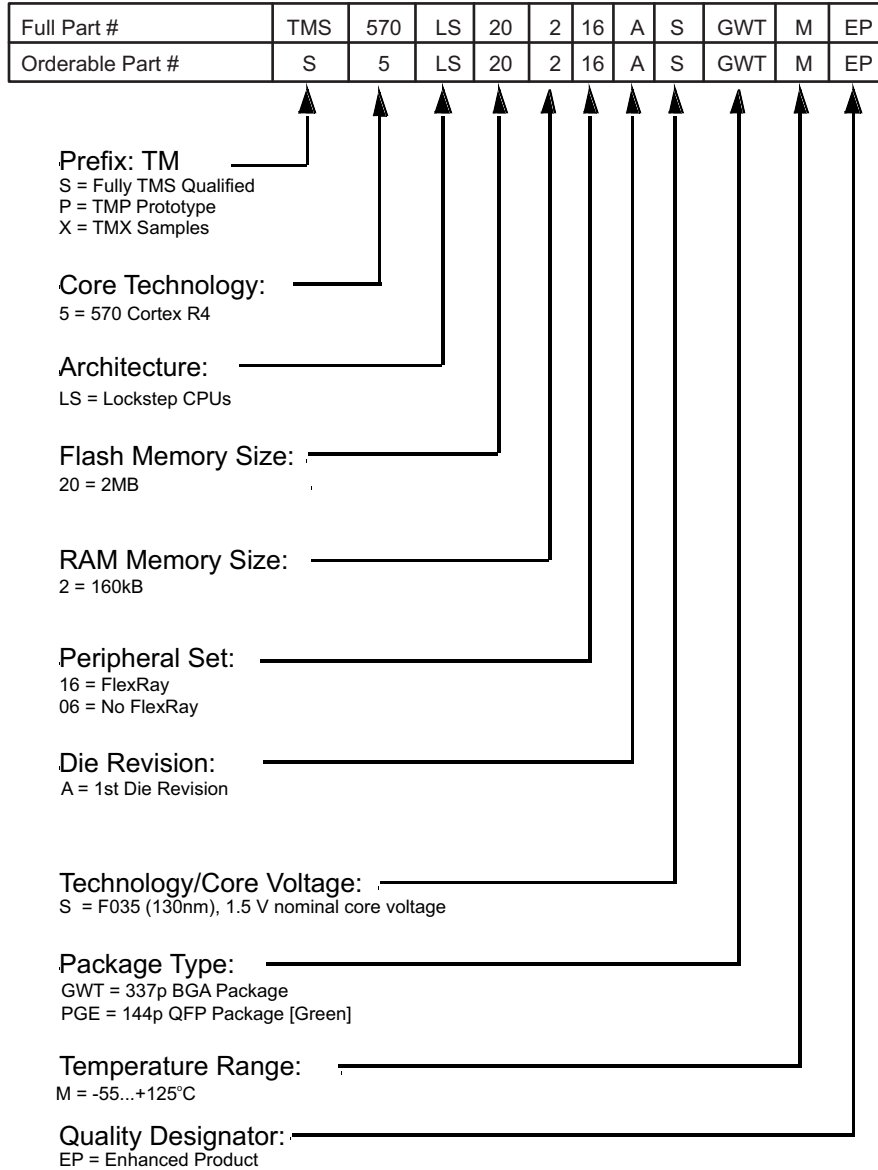

A. For actual device part numbers (P/Ns) and ordering information, see the TI website (<http://www.ti.com>).

Figure 2-7. Device Numbering Conventions^(A)

3 Reset / Abort Sources

3.1 Reset / Abort Sources

The device Resets and Aborts are handled as shown in the following table. The table shows the source of the error, the system mode, the type of error response and the corresponding Error Signaling Module (ESM) channel. Only standard ARM exception handlers and ESM errors are used.

Table 3-1. Reset / Abort Sources

Error Source	System Mode	Error Response	ESM Hookup group channel
1) CPU transactions			
Precise write error (Strongly Ordered)	User/Privilege	Precise Abort (CPU)	n/a
Precise read error (Device or Normal)	User/Privilege	Precise Abort (CPU)	n/a
Imprecise write error (Device or Normal)	User/Privilege	Imprecise Abort (CPU)	n/a
Illegal instruction	User/Privilege	Undefined Instruction Trap (CPU) ⁽¹⁾	n/a
MPU access violation	User/Privilege	Abort (CPU)	n/a
2) SRAM			
B0 Tightly Coupled Memory (TCM) (even) ECC single error (correctable)	User/Privilege	ESM	1.26
B0 TCM (even) ECC double error (non-correctable)	User/Privilege	Abort (CPU), ESM => nERROR	3.3
B0 TCM (even) uncorrectable error (i.e. redundant address decode)	User/Privilege	ESM => NMI	2.6
B0 TCM (even) address bus parity error	User/Privilege	ESM => NMI	2.10
B1 TCM (odd) ECC single error (correctable)	User/Privilege	ESM	1.28
B1 TCM (odd) ECC double error (non-correctable)	User/Privilege	Abort (CPU), ESM => nERROR	3.5
B1 TCM (odd) uncorrectable error (i.e. redundant address decode)	User/Privilege	ESM => NMI	2.8
B1 TCM (odd) address bus parity error	User/Privilege	ESM => NMI	2.12
3) Flash with ECC INTEGRATED INTO CPU			
ECC single error (correctable)	User/Privilege	ESM	1.6
ECC double error (non-correctable)	User/Privilege	Abort (CPU), ESM => nERROR	3.7
Uncorrectable error (i.e. redundant address tag, redundant syndrome compare, address bus parity, etc.)	User/Privilege	ESM => NMI	2.4
4) DMA transactions			
External imprecise error on read (Illegal transaction with ok response)	User/Privilege	ESM	1.5
External imprecise error on write (Illegal transaction with ok response)	User/Privilege	ESM	1.13

(1) The Undefined Instruction TRAP is NOT detectable outside the CPU. The trap is taken only if the Code reaches the execute stage of the CPU.

Table 3-1. Reset / Abort Sources (continued)

Error Source	System Mode	Error Response	ESM Hookup group channel
Memory access permission violation	User/Privilege	ESM	1.2
Memory parity error	User/Privilege	ESM	1.3
5) DMM transactions			
External imprecise error on read (Illegal transaction with ok response)	User/Privilege	ESM	1.5
External imprecise error on write (Illegal transaction with ok response)	User/Privilege	ESM	1.13
6) AHB-AP transactions			
External imprecise error on read (Illegal transaction with ok response)	User/Privilege	ESM	1.5
External imprecise error on write (Illegal transaction with ok response)	User/Privilege	ESM	1.13
7) HET TU			
NCNB (Strongly Ordered) transaction with slave error response	User/Privilege	Interrupt => VIM	n/a
External imprecise error (Illegal transaction with ok response)	User/Privilege	Interrupt => VIM	n/a
Memory access permission violation	User/Privilege	ESM	1.9
Memory parity error	User/Privilege	ESM	1.8
8) NHET			
Memory parity error	User/Privilege	ESM	1.7
9) MibSPI			
MibSPI1 memory parity error	User/Privilege	ESM	1.17
MibSPI3 memory parity error	User/Privilege	ESM	1.18
MibSPI5 memory parity error	User/Privilege	ESM	1.24
10) MibADC			
MibADC1 memory parity error	User/Privilege	ESM	1.19
MibADC2 memory parity error	User/Privilege	ESM	1.1
11) DCAN			
DCAN1 memory parity error	User/Privilege	ESM	1.21
DCAN2 memory parity error	User/Privilege	ESM	1.23
DCAN3 memory parity error	User/Privilege	ESM	1.22
12) PLL			
PLL slip error	User/Privilege	ESM	1.10
13) Clock monitor			
Clock monitor interrupt	User/Privilege	ESM	1.11
14) CCM			
Self test failure	User/Privilege	ESM	1.31
Compare failure	User/Privilege	ESM => NMI	2.2
15) FlexRay			
Memory parity error	User/Privilege	ESM	1.12
16) FlexRay TU			
NCNB (Strongly Ordered) transaction with slave error response	User/Privilege	Interrupt => VIM	n/a

Table 3-1. Reset / Abort Sources (continued)

Error Source	System Mode	Error Response	ESM Hookup group channel
External imprecise error (Illegal transaction with ok response)	User/Privilege	Interrupt => VIM	n/a
Memory access permission violation	User/Privilege	ESM	1.16
Memory parity error	User/Privilege	ESM	1.14
17) VIM			
Memory parity error	User/Privilege	ESM	1.15
18) voltage monitor			
VMON out of voltage range	n/a	Reset	n/a
19) CPU Selftest (LBIST)			
CPU Selftest (LBIST) error	User/Privilege	ESM	1.27
20) errors reflected in the SYSESR register			
Power-Up Reset; VCC out of voltage range	n/a	Reset	n/a
Oscillator fail / PLL slip ⁽²⁾	n/a	Reset	n/a
Watchdog time limit exceeded	n/a	Reset	n/a
CPU Reset	n/a	Reset	n/a
Software Reset	n/a	Reset	n/a
External Reset	n/a	Reset	n/a

(2) Oscillator fail/PLL slip can be configured in the system register PLLCTL1 to generate a reset.

4 Peripherals

4.1 Error Signaling Module (ESM)

The Error Signaling Module (ESM) is used to indicate a severe device failure via interrupts and the external `ERROR` pin. The error pin is normally used by an external device to either reset the controller and/or keep the system in a fail safe state.

The ESM module consists of three error groups with 32 inputs each. The generation of the interrupts and the activation of the `ERROR` Pin is shown in the following table. The next table shows the ESM error sources and their corresponding group and channel numbers.

Table 4-1. ESM Groups

Error Group	Interrupt, Level	Influence on <code>ERROR</code> pin
Group1	maskable, low/high	configurable
Group2	non-maskable, high	fixed
Group3	none, none	fixed

Table 4-2. ESM Assignments

ERROR Sources	Group	Channels
Reserved	Group1	0
MibADC2 - parity	Group1	1
DMA - MPU	Group1	2
DMA - parity	Group1	3
Reserved	Group1	4
DMA/DMM/AHB-AP - imprecise read error	Group1	5
Flash (ATCM) - correctable error	Group1	6
NHET - parity	Group1	7
HET TU - parity	Group1	8
HET TU - MPU	Group1	9
PLL - slip	Group1	10
Clock Monitor - interrupt	Group1	11
FlexRay - parity	Group1	12
DMA/DMM/AHB-AP - imprecise write error	Group1	13
FlexRay TU - parity	Group1	14
VIM RAM - parity	Group1	15
FlexRay TU - MPU	Group1	16
MibSPI1 - parity	Group1	17
MibSPI3 - parity	Group1	18
MibADC1 - parity	Group1	19
Reserved	Group1	20
DCAN1 - parity	Group1	21
DCAN3 - parity	Group1	22
DCAN2 - parity	Group1	23
MibSPI5 - parity	Group1	24
Reserved	Group1	25
RAM even bank (B0TCM) - correctable error	Group1	26
CPU - selftest	Group1	27
RAM odd bank (B1TCM) - correctable error	Group1	28
Reserved	Group1	29
Reserved	Group1	30

Table 4-2. ESM Assignments (continued)

ERROR Sources	Group	Channels
CCM-R4 - selftest	Group1	31
Reserved	Group2	0
Reserved	Group2	1
CCM-R4 - compare	Group2	2
Reserved	Group2	3
Flash (ATCM) - uncorrectable error	Group2	4
Reserved	Group2	5
RAM even bank (B0TCM) - uncorrectable error	Group2	6
Reserved	Group2	7
RAM odd bank (B1TCM) - uncorrectable error	Group2	8
Reserved	Group2	9
RAM even bank (B0TCM) - address bus parity error	Group2	10
Reserved	Group2	11
RAM odd bank (B1TCM) - address bus parity error	Group2	12
Reserved	Group2	13
Reserved	Group2	14
Reserved	Group2	15
Flash (ATCM) - ECC live lock detect	Group2	16
Reserved	Group2	17
Reserved	Group2	18
Reserved	Group2	19
Reserved	Group2	20
Reserved	Group2	21
Reserved	Group2	22
Reserved	Group2	23
Reserved	Group2	24
Reserved	Group2	25
Reserved	Group2	26
Reserved	Group2	27
Reserved	Group2	28
Reserved	Group2	29
Reserved	Group2	30
Reserved	Group2	31
Reserved	Group3	0
Reserved	Group3	1
Reserved	Group3	2
RAM even bank (B0TCM) - ECC uncorrectable error	Group3	3
Reserved	Group3	4
RAM odd bank (B1TCM) - ECC uncorrectable error	Group3	5
Reserved	Group3	6
Flash (ATCM) - ECC uncorrectable error	Group3	7
Reserved	Group3	8
Reserved	Group3	9
Reserved	Group3	10
Reserved	Group3	11
Reserved	Group3	12
Reserved	Group3	13

Table 4-2. ESM Assignments (continued)

ERROR Sources	Group	Channels
Reserved	Group3	14
Reserved	Group3	15
Reserved	Group3	16
Reserved	Group3	17
Reserved	Group3	18
Reserved	Group3	19
Reserved	Group3	20
Reserved	Group3	21
Reserved	Group3	22
Reserved	Group3	23
Reserved	Group3	24
Reserved	Group3	25
Reserved	Group3	26
Reserved	Group3	27
Reserved	Group3	28
Reserved	Group3	29
Reserved	Group3	30
Reserved	Group3	31

4.2 Direct Memory Access (DMA)

The direct-memory access (DMA) controller transfers data to and from any specified location in the device memory map. The DMA supports data transfer for both on-chip memories and peripherals.

The DMA controller on this device supports 16 channels and 32 request lines. Each of the 32 DMA requests are assigned by default to one of the 16 available channels. For DMA requests multiplexed between multiple sources, the DMA controller cannot differentiate between the multiple sources and the user has to ensure that multiple sources are not enabled at the same time. Please refer to the DMA Specification in the TRM for more details.

The DMA request configuration is shown in the following table.

Table 4-3. DMA Request Line Connection

Modules	DMA Request Sources	DMA Request
MIBSPI1	MIBSPI1[1] ⁽¹⁾	DMAREQ[0]
MIBSPI1	MIBSPI1[0] ⁽²⁾	DMAREQ[1]
Reserved	Reserved	DMAREQ[2]
Reserved	Reserved	DMAREQ[3]
MIBSPI1 / MIBSPI3 / DCAN2	MIBSPI1[2] / MIBSPI3[2] / DCAN2 IF3	DMAREQ[4]
MIBSPI1 / MIBSPI3 / DCAN2	MIBSPI1[3] / MIBSPI3[3] / DCAN2 IF2	DMAREQ[5]
MIBSPIP5 / DCAN1	MIBSPIP5[2] / DCAN1 IF2	DMAREQ[6]
MIBADC1 / MIBSPIP5	MIBADC1 event / MIBSPIP5[3]	DMAREQ[7]
MIBSPI1 / MIBSPI3 / DCAN1	MIBSPI1[4] / MIBSPI3[4] / DCAN1 IF1	DMAREQ[8]
MIBSPI1 / MIBSPI3 / DCAN2	MIBSPI1[5] / MIBSPI3[5] / DCAN2 IF1	DMAREQ[9]
MIBADC1 / MIBSPIP5	MIBADC1 G1 / MIBSPIP5[4]	DMAREQ[10]
MIBADC1 / MIBSPIP5	MIBADC1 G2 / MIBSPIP5[5]	DMAREQ[11]
RTI / MIBSPI1 / MIBSPI3	RTI DMAREQ0 / MIBSPI1[6] / MIBSPI3[6]	DMAREQ[12]
RTI / MIBSPI1 / MIBSPI3	RTI DMAREQ1 / MIBSPI1[7] / MIBSPI3[7]	DMAREQ[13]
MIBADC2 / MIBSPI3 / MIBSPIP5	MIBADC2 event / MIBSPI3[1] ⁽¹⁾ / MIBSPIP5[6]	DMAREQ[14]
MIBSPI3 / MIBSPIP5	MIBSPI3[0]† / MIBSPIP5[7]	DMAREQ[15]
MIBADC2 / MIBSPI1 / MIBSPI3 / DCAN1	MIBADC2 G1 / MIBSPI1[8] / MIBSPI3[8] / DCAN1 IF3	DMAREQ[16]
MIBADC2 / MIBSPI1 / MIBSPI3 / DCAN3	MIBADC2 G2 / MIBSPI1[9] / MIBSPI3[9] / DCAN3 IF1	DMAREQ[17]
RTI / MIBSPIP5	RTI DMAREQ2 / MIBSPIP5[8]	DMAREQ[18]
RTI / MIBSPIP5	RTI DMAREQ3 / MIBSPIP5[9]	DMAREQ[19]
LIN2 / NHET / DCAN3	LIN2 receive / NHET DMAREQ[4] / DCAN3 IF2	DMAREQ[20]
LIN2 / NHET / DCAN3	LIN2 transmit / NHET DMAREQ[5] / DCAN3 IF3	DMAREQ[21]
MIBSPI1 / MIBSPI3 / MIBSPIP5	MIBSPI1[10] / MIBSPI3[10] / MIBSPIP5[10]	DMAREQ[22]
MIBSPI1 / MIBSPI3 / MIBSPIP5	MIBSPI1[11] / MIBSPI3[11] / MIBSPIP5[11]	DMAREQ[23]
NHET / MIBSPIP5	NHET DMAREQ[6] / MIBSPIP5[12]	DMAREQ[24]
NHET / MIBSPIP5	NHET DMAREQ[7] / MIBSPIP5[13]	DMAREQ[25]
CRC / MIBSPI1 / MIBSPI3	CRC DMAREQ[0] / MIBSPI1[12] / MIBSPI3[12]	DMAREQ[26]
CRC / MIBSPI1 / MIBSPI3	CRC DMAREQ[1] / MIBSPI1[13] / MIBSPI3[13]	DMAREQ[27]
LIN1 / MIBSPIP5	LIN1 receive / MIBSPIP5[14]	DMAREQ[28]
LIN1 / MIBSPIP5	LIN1 transmit / MIBSPIP5[15]	DMAREQ[29]
MIBSPI1 / MIBSPI3 / MIBSPIP5	MIBSPI1[14] / MIBSPI3[14] / MIBSPIP5[1] ⁽¹⁾	DMAREQ[30]
MIBSPI1 / MIBSPI3 / MIBSPIP5	MIBSPI1[15] / MIBSPI3[15] / MIBSPIP5[0] ⁽²⁾	DMAREQ[31]

(1) SPI1, SPI3, SPI5 receive in standard SPI/compatibility mode

(2) SPI1, SPI3, SPI5 transmit in standard SPI/compatibility mode

4.3 High End Timer Transfer Unit (HET-TU)

The High End Timer Transfer Unit (HET-TU) is a local Direct Memory Access (DMA) module. It is specifically designed to transfer High End Timer (NHET) data to (or from) the CPU data SRAM . The HET software controls which HET instructions generate transfer requests to the transfer unit. More information about the NHET and the HET-TU can be found in the technical reference manual (TRM). The HET-TU supports 8 channels.

The HET-TU request assignment is shown in the following table.

Table 4-4. NHET Request Line Connection

Modules	Request Source	HET TRANSFER UNIT Request
NHET	HTUREQ[0]	HET TU DCP[0]
NHET	HTUREQ[1]	HET TU DCP[1]
NHET	HTUREQ[2]	HET TU DCP[2]
NHET	HTUREQ[3]	HET TU DCP[3]
NHET	HTUREQ[4]	HET TU DCP[4]
NHET	HTUREQ[5]	HET TU DCP[5]
NHET	HTUREQ[6]	HET TU DCP[6]
NHET	HTUREQ[7]	HET TU DCP[7]

4.4 Vectored Interrupt Manager (VIM)

The Vectored Interrupt Manager (VIM) provides hardware assistance for prioritizing and controlling the many interrupt sources present on the device. Interrupt requests originating from the device modules (i.e., SPI, LIN, SCI, etc.) are assigned to channels within the 64-channel VIM. Programming multiple interrupt sources to the same VIM channel effectively shares the VIM channel between sources. The VIM request channels are maskable so that individual channels can be selectively disabled. All interrupt requests can be programmed in the VIM to be of either type:

- Fast interrupt request (FIQ)- The FIQ implemented in Cortex-R4F is Non-Maskable Fast Interrupts (NMFI).
- Normal interrupt request (IRQ)

The VIM prioritizes interrupts, whose precedence of request channels decrease with ascending channel order in the VIM (0 [highest] and 64[lowest] priority). For VIM default mapping, channel priorities, and their associated modules see the table below. More information on the VIM can be found in the technical reference manual (TRM).

Table 4-5. Interrupt Request Assignments

Modules	Interrupt Sources	Default VIM Interrupt Request
ESM	ESM High level interrupt (NMI)	0
Reserved	(NMI)	1
RTI	RTI compare interrupt 0	2
RTI	RTI compare interrupt 1	3
RTI	RTI compare interrupt 2	4
RTI	RTI compare interrupt 3	5
RTI	RTI overflow interrupt 0	6
RTI	RTI overflow interrupt 1	7
RTI	RTI timebase	8
GIO	GIO interrupt A	9
NHET	NHET level 1 interrupt	10
HET TU	HET TU level 1 interrupt	11
MIBSPI1	MIBSPI1 level 0 interrupt	12
LIN1 (incl. SCI)	LIN1 level 0 interrupt	13
MIBADC1	MIBADC1 event group interrupt	14
MIBADC1	MIBADC1 sw group 1 interrupt	15
DCAN1	DCAN1 level 0 interrupt	16
Reserved	Reserved	17
FlexRay	FlexRay level 0 interrupt	18
CRC	CRC Interrupt	19
ESM	ESM Low level interrupt	20
SYSTEM	Software interrupt (SSI)	21
CPU	PMU Interrupt	22
GIO	GIO interrupt B	23
NHET	NHET level 2 interrupt	24
HET TU	HET TU level 2 interrupt	25
MIBSPI1	MIBSPI1 level 1 interrupt	26
LIN1 (incl. SCI)	LIN1 level 1 interrupt	27
MIBADC1	MIBADC1 sw group 2 interrupt	28
DCAN1	DCAN1 level 1 interrupt	29
Reserved	Reserved	30
MIBADC1	MIBADC1 magnitude interrupt	31

Table 4-5. Interrupt Request Assignments (continued)

Modules	Interrupt Sources	Default VIM Interrupt Request
FlexRay	FlexRay level 1 interrupt	32
DMA	FTCA interrupt	33
DMA	LFSA interrupt	34
DCAN2	DCAN2 level 0 interrupt	35
DMM	DMM level 0 interrupt	36
MIBSPI3	MIBSPI3 level 0 interrupt	37
MIBSPI3	MIBSPI3 level 1 interrupt	38
DMA	HBCA interrupt	39
DMA	BTCA interrupt	40
Reserved	Reserved	41
DCAN2	DCAN2 level 1 interrupt	42
DMM	DMM level 1 interrupt	43
DCAN1	DCAN1 IF3 interrupt	44
DCAN3	DCAN3 level 0 interrupt	45
DCAN2	DCAN2 IF3 interrupt	46
FPU	FPU interrupt	47
FlexRay TU	FlexRay TU Transfer Status interrupt	48
LIN2 (incl. SCI)	LIN2 level 0 interrupt	49
MIBADC2	MIBADC2 event group interrupt	50
MIBADC2	MIBADC2 sw group 1 interrupt	51
FlexRay	FlexRay T0C interrupt	52
MIBSPIP5	MIBSPIP5 level 0 interrupt	53
LIN2 (incl. SCI)	LIN2 level 1 interrupt	54
DCAN3	DCAN3 level 1 interrupt	55
MIBSPIP5	MIBSPIP5 level 1 interrupt	56
MIBADC2	MIBADC2 sw group 2 interrupt	57
FlexRay TU	FlexRay TU Error interrupt	58
MIBADC2	MIBADC2 magnitude interrupt	59
DCAN3	DCAN3 IF3 interrupt	60
Reserved	Reserved	61
FlexRay	FlexRay T1C interrupt	62
Reserved	Reserved	63

Note: Address location 0x00000000 in the VIM RAM is reserved for the phantom interrupt ISR entry.

4.5 MIBADC Event Trigger Sources

All three conversion groups can be configured for event-triggered operation, providing up to three event triggered groups.

The trigger source and polarity can be selected individually for group 1, group 2 and the event group from the options identified in the first table following for MibADC1 and in the second table following for MibADC2.

Table 4-6. MIBADC1 Event Trigger Sources

Event #	SOURCE SELECT BITS for G1, G2 or EVENT (G1SRC[2:0], G2SRC[2:0] or EVSRC[2:0])	Hookup
1	000	AD1EVT
2	001	NHET[8]
3	010	NHET[10]
4	011	RTI compare 0
5	100	NHET[17]
6	101	NHET[19]
7	110	GIOB[0]
8	111	GIOB[1]

NOTE

The Trigger is present, even if the pin is not available.

Table 4-7. MIBADC2 Event Trigger Sources

Event #	SOURCE SELECT BITS for G1, G2 or EVENT (G1SRC[2:0], G2SRC[2:0] or EVSRC[2:0])	Hookup
1	000	AD2EVT
2	001	NHET[8]
3	010	NHET[10]
4	011	RTI compare 0
5	100	NHET[17]
6	101	NHET[19]
7	110	GIOB[0]
8	111	GIOB[1]

NOTE

The Trigger is present, even if the pin is not available.

The application can generate the trigger condition using these signals by configuring the corresponding device pins as input pins and driving them from an external source, or by configuring them as output pins and driving them by software. The pin doesn't have to be present on the package to be able to be used as a trigger.

The interrupt request signals (RTI compare 0) are driven HIGH when the interrupt condition occurs. So if the ADC is required to be triggered on the interrupt being asserted, select the rising edge for this trigger source. The ADC can be still triggered using the falling edge on the interrupt line. In this case, the falling edge occurs when the interrupt line is deasserted.

4.6 MIBSPI

4.6.1 MIBSPI Event Trigger Sources

The Multi-buffered Serial Peripheral Interfaces (MIBSPIs) have a programmable buffer memory that enables data transmission to be completed without CPU intervention. The buffers are combined in different Transfer Groups (TGs) that can be triggered by external events such as I/O activity, timers or by the internal tick counter. The internal tick counter supports the periodic trigger of events. Each buffer of the MibSPI can be associated with different DMA channels in different TGs, allowing the user to move data between internal memory and an external slave with minimal CPU interaction.

Table 4-8. MIBSPI1 Event Trigger Sources

Event	TGxCTRL TRIGSRC[3:0]	Hookup
Disabled	0000	No trigger source
EVENT0	0001	GIOA[0]
EVENT1	0010	GIOA[1]
EVENT2	0011	GIOA[2]
EVENT3	0100	GIOA[3]
EVENT4	0101	GIOA[4]
EVENT5	0110	GIOA[5]
EVENT6	0111	GIOA[6]
EVENT7	1000	GIOA[7]
EVENT8	1001	NHET[8]
EVENT9	1010	NHET[10]
EVENT10	1011	NHET[12]
EVENT11	1100	NHET[14]
EVENT12	1101	NHET[16]
EVENT13	1110	NHET[18]
EVENT14	1111	Internal Tick counter

Table 4-9. MIBSPI3 Event Trigger Sources

Event	TGxCTRL TRIGSRC[3:0]	Hookup
Disabled	0000	No trigger source
EVENT0	0001	GIOA[0]
EVENT1	0010	GIOA[1]
EVENT2	0011	GIOA[2]
EVENT3	0100	GIOA[3]
EVENT4	0101	GIOA[4]
EVENT5	0110	GIOA[5]
EVENT6	0111	GIOA[6]
EVENT7	1000	GIOA[7]
EVENT8	1001	NHET[8]
EVENT9	1010	NHET[10]
EVENT10	1011	NHET[12]
EVENT11	1100	NHET[14]
EVENT12	1101	NHET[16]
EVENT13	1110	NHET[18]
EVENT14	1111	Internal Tick counter

Table 4-10. MIBSPI5 Event Trigger Sources

Event	TGxCTRL TRIGSRC[3:0]	Hookup
Disabled	0000	No trigger source
EVENT0	0001	GIOA[0]
EVENT1	0010	GIOA[1]
EVENT2	0011	GIOA[2]
EVENT3	0100	GIOA[3]
EVENT4	0101	GIOA[4]
EVENT5	0110	GIOA[5]
EVENT6	0111	GIOA[6]
EVENT7	1000	GIOA[7]
EVENT8	1001	NHET[8]
EVENT9	1010	NHET[10]
EVENT10	1011	NHET[12]
EVENT11	1100	NHET[14]
EVENT12	1101	NHET[16]
EVENT13	1110	NHET[18]
EVENT14	1111	Internal Tick counter

4.6.2 MIBSPI5/DMM Pin Multiplexing

The multiplexing of MIBSPI5 and DMM pins are controlled by the status of the MIBSPI5 module and the DMM module. The pins will have DMM functionality if the DMM module is enabled and the MIBSPI5 module is disabled; if the MIBSPI5 is enabled the pins will have MIBSPI functionality, regardless of the DMM module status. DMMCLK, DMMSYNC, DMMENA and DMMDATA[1:0] are always functional independent of the MIBSPI5 configuration because they are not multiplexed. The related pin numbers can be found in the MIBSPI5 and the DMM section of the Terminal Functions chapter. The following table shows the MIBSPI5 and DMM Data pin multiplexing.

Table 4-11. MIBSPI5 Pin Multiplexing

MIBSPI5 enabled	DMM enabled & MIBSPI5 disabled
MIBSPI5CLK	DMMDATA[4]
$\overline{\text{MIBSPI5CS}}[0]$	DMMDATA[5]
$\overline{\text{MIBSPI5CS}}[1]$	DMMDATA[6]
$\overline{\text{MIBSPI5CS}}[2]$	DMMDATA[2]
$\overline{\text{MIBSPI5CS}}[3]$	DMMDATA[3]
MIBSPI5ENA	DMMDATA[7]
MIBSPI5SIMO[0]	DMMDATA[8]
MIBSPI5SIMO[1]	DMMDATA[9]
MIBSPI5SIMO[2]	DMMDATA[10]
MIBSPI5SIMO[3]	DMMDATA[11]
MIBSPI5SOMI[0]	DMMDATA[12]
MIBSPI5SOMI[1]	DMMDATA[13]
MIBSPI5SOMI[2]	DMMDATA[14]
MIBSPI5SOMI[3]	DMMDATA[15]

4.7 ETM

The device contains an ARM Cortex™-R4F External Trace Macrocell (ETM-R4) with a 32bit data port. The ETM-R4 module is connected to a Test Port Interface Unit (TPIU) with a 32bit data bus. The ETM-R4 is CoreSight compliant and follows the ARM ETM v3 specification; for more details see ARM CoreSight™ ETM-R4 TRM specification Revr0p0. The ETM-R4 supports "half rate clocking" only.

The ETM clock source can be selected as either VCLK or the external ETMTRACECLKIN pin. The selection is done by the EXTCTRLOUT[1:0] control bits of the TPIU; the default is '00'.

Table 4-12. ETMTRACECLKIN Selection

EXTCTRLOUT[1:0]	TPIU/TRACECLKIN
00	tied-zero
01	VCLK
10	ETMTRACECLKIN
11	tied-zero

4.8 Debug Scan Chains

The device contains an ICEPICK module to access the debug scan chains. Debug scan chain #0 handles the access to the CPU, to the ETM-R4 (External Trace Macrocell), to the POM (Parameter Overlay Module) and to the TPIU (Test Port Interface Unit). Debug scan chain #1 handles the access to the Ram Trace Port (RTP) and the Data Modification Module (DMM) which each incorporate a dedicated TAP (Test Access Port) controller. Each module is selected via its scan chain number. The IcePick scan ID is 0x80206D05, which is the same number as the device ID.

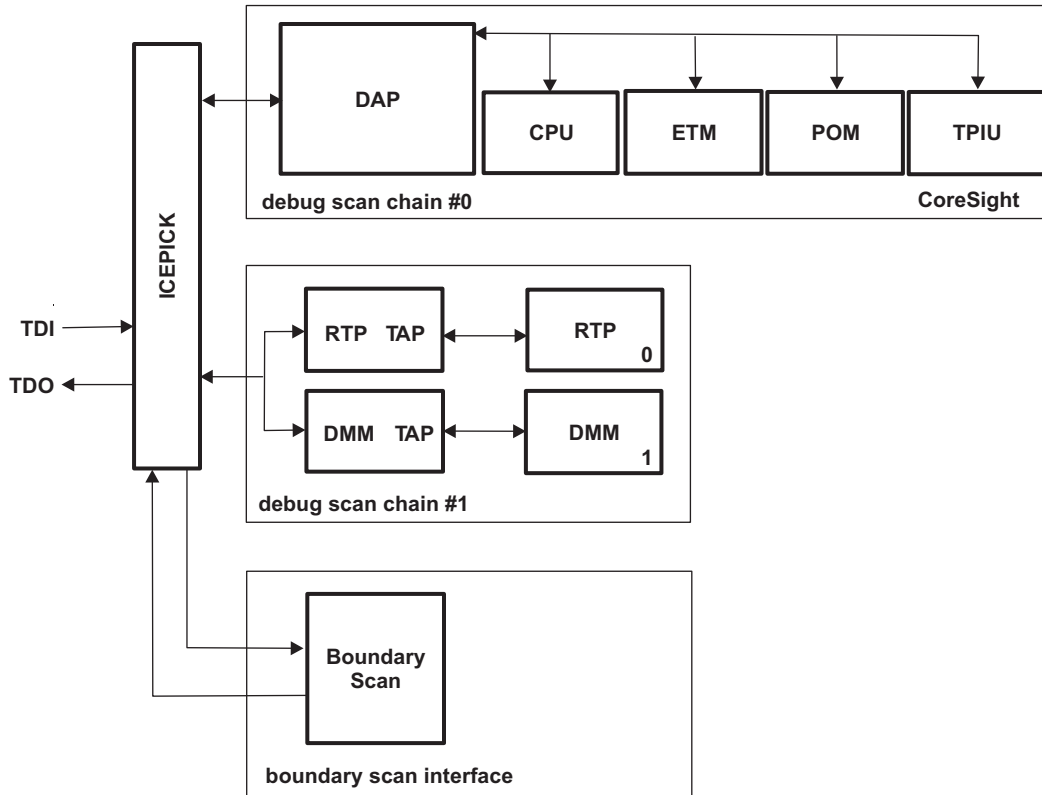

Figure 4-1. Debug Scan Chains

4.8.1 JTAG

The 32bit JTAG ID code for this device is 0x0B7B302F.

4.9 CCM

4.9.1 Dual Core Implementation

The microcontroller has two Cortex-R4 cores, where the output signals of both CPUs are compared in the CCM-R4 (Core Compare Module). To avoid common mode impacts the signals of the CPUs to be compared are delayed in a different way as shown in the following figure.

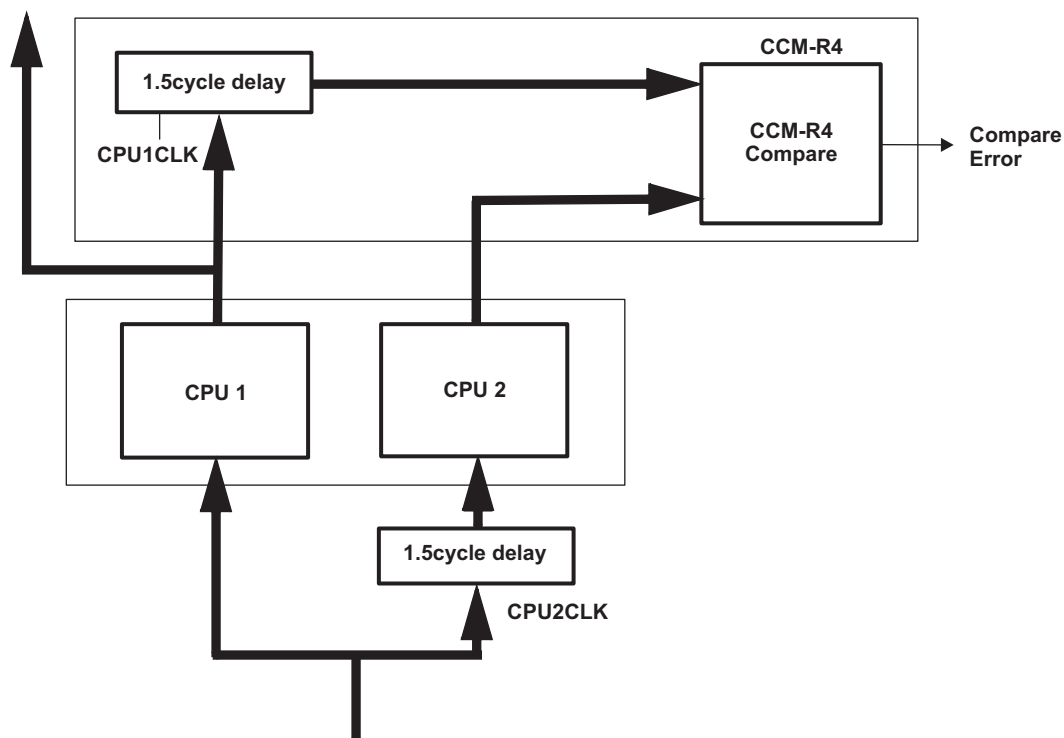

Figure 4-2. Dual Core Implementation

4.9.2 CCM-R4

To avoid an erroneous CCM-R4 compare error, the application software must ensure that the CPU registers of both CPUs are initialized with the same values before the 1st function call or other operation that pushes the CPU registers onto the stack. All CCM-R4 error forcing test modes are limited to 100MHz HCLK speed.

4.10 LPM

TMS570 Platform devices support multiple low power modes. These different modes allow the user to trade-off the amount of current consumption during low power mode versus functionality and wake-up time.

Supported Low Power modes on this devices are Doze, Snooze and Sleep; for detailed description please refer to the Architecture section of the Technical Reference Manual.

4.11 Voltage Monitor

A voltage monitor has been implemented on this device. The purpose of this voltage monitor is to eliminate the requirement for a specific sequence when powering up the core and I/O voltage supplies. It also reduces the risk of corrupting memory or glitches on I/O pins during power-up, power-down or brown outs. The voltage monitor does not eliminate the need of a voltage supervisor circuit to guarantee that the device is held in reset when the voltage supplies are out of range. The voltage monitor thresholds can be found in the Vmon section of the device electrical specifications.

When the voltage monitor detects a low voltage on the I/O supply, it will assert a reset. When the voltage monitor detects a low voltage on the core supply, it asynchronously makes all output pins high impedance, and asserts a reset. The voltage monitor is disabled when the device is in halt mode.

The voltage monitor has three filter functions:

- It rejects short low-going glitches on the $\overline{\text{PORRST}}$ pin
- It rejects noise on the VCCIO supply
- It rejects noise on the VCC supply

Please note that such glitches on VCC and VCCIO could still corrupt the system depending on many factors. The width of noise that can be filtered by the voltage monitor on the VCC and VCCIO supplies is shown in the table below. Glitches less than MIN will be filtered out, glitches greater than MAX are guaranteed to generate a reset. The duration of glitches that will be filtered on the $\overline{\text{PORRST}}$ pin can be found in [Table 7-6, Timing Requirements for \$\overline{\text{PORRST}}\$](#) .

Table 4-13. VMON Supply Glitch Filter Capability

Parameter	Min	Max
Width of glitch on VCC that can be filtered out	300ns	1us
Width of glitch on VCCIO that can be filtered out	300ns	1us

4.12 CRC

MCRC Controller is a module which is used to perform CRC (Cyclic Redundancy Check) to verify the integrity of memory system. A signature representing the contents of the memory is obtained when the contents of the memory are read into MCRC Controller. The responsibility of MCRC controller is to calculate the signature for a set of data and then compare the calculated signature value against a pre-determined good signature value. MCRC controller provides up to four channels to perform CRC calculation on multiple memories in parallel and can be used on any memory system. Channel 1 can also be put into data trace mode. In data trace mode, MCRC controller compresses each data being read through the CPU read data bus.

When using the MCRC module in PSA mode while ECC is enabled, bus masters (e.g. FTU, HTU, DMA or CPU) should not write to the data RAM (TCRAM) to avoid corrupting the PSA value.

4.13 System Module Access

The system module access modes and access rights are shown in the following table.

Table 4-14. System Module Access

Domain	Module	Access Mode Used by Module	Access Rights Required to Access the Module RAMS
System	VIM	n/a	privilege mode (RWP)
System	RTP	n/a	privilege mode (RWP)
System	DMA	user mode	privilege mode (RWP)
Peripheral	HTU	privilege mode	privilege mode (RWP)
Peripheral	FTU	user & privilege mode	user & privilege mode (RW)

4.14 Debug ROM

The Debug ROM stores the location of the components on the Debug APB bus.

Table 4-15. Debug ROM Table

Address	Description	Value
Components Table		
0x000	pointer to Cortex-R4	0x00001003
0x000	ETM	0x00002003
0x000	TPIU	0x00003003
0x000	POM	0x00004003
0x001	end of table	0x00000000

4.15 CPU Self Test Controller: STC / LBIST

The CPU Self Test Controller (STC) is used to test the ARM CPU core using a Deterministic Logic BIST (LBIST) Controller as the test engine. The STC has the capability of dividing the complete test run into smaller independent test sets (intervals). The test coverage and number of test execution cycles for each test interval is shown in the table below.

The maximum clock rate for the STC / LBIST is:

- 53.333MHz when HCLK = 160MHz / VCLK = 80MHz on BGA package
- 50MHz when HCLK = 100MHz / VCLK = 100MHz on QFP and BGA packages
- 46.666MHz when HCLK = 140MHz / VCLK = 70MHz on QFP and BGA packages

In order to achieve the proper clock rate during CPU self test a STC clock divider has been implemented. The clock divider is set by the CLKDIV bits in STCCCLKDIV register in the secondary system module frame at location 0xFFFF E108. The default value of the CPU Self Test LBIST clock divider is set to 'divide-by-1'.

NOTE

The supply current while performing CPU self test is different than the device operating mode current. These values can be found in the I_{cc} section of [Section 6.5](#).

Table 4-16. STC/LBIST Test Coverage and Duration

Intervals	Test Coverage	Test Cycles (STC Clock Cycles)
0	0%	0
1	57.14%	1,555
2	65.82%	3,108
3	70.56%	4,661
4	73.56%	6,214
5	76.06%	7,767
6	78.07%	9,320
7	79.62%	10,873
8	80.92%	12,426
9	82.1%	13,979
10	82.94%	15,532
11	83.76%	17,085
12	84.51%	18,638
13	85.12%	20,191
14	85.62%	21,744
15	86.19%	23,297
16	86.56%	24,850
17	86.97%	26,403
18	87.33%	27,956
19	87.67%	29,509
20	88.01%	31,062
21	88.31%	32,615
22	88.58%	34,168
23	88.87%	35,721
24	89.11%	37,274
25	89.34%	38,827
26	89.59%	40,380
27	89.82%	41,933
28	90.05%	43,486

Table 4-16. STC/LBIST Test Coverage and Duration (continued)

Intervals	Test Coverage	Test Cycles (STC Clock Cycles)
29	90.26%	45,039
30	90.46%	46,592
31	90.64%	48,145
32	90.84%	49,698

5 Device Registers

5.1 Device Identification Code Register

The device identification code register identifies several aspects of the device including the silicon version. The details of the device identification code register are shown in [Figure 5-1](#). The device identification code register value for this device is:

- Rev 0 = 0x80206D05
- Rev A = 0x80206D0D

Figure 5-1. Device ID Bit Allocation Register

31	30	29	28	27	26	25	24	23	22	21	20	19	18	17	16
CP-15	UNIQUE ID														16
R-1	R-00000 0000 10000														R-0
15	14	13	12	11	10	9	8	7	6	5	4	3	2	1	0
TECH		I/O VOLT AGE	PERIP HERA L PARIT Y	FLASH ECC		RAM ECC		VERSION					1	0	1
R-011		R-0	R-1	R-10		R-1		R-1					R-1	R-0	R-1

LEGEND: R/W = Read/Write; R = Read only; -n = value after reset; D= device dependent

Table 5-1. Device ID Bit Allocation Register Field Descriptions

Bit	Field	Value	Description
31	CP15	0 1	Indicates the presence of coprocessor 15 CP15 not present CP15 present
30-17	UNIQUE ID	1	Silicon version (revision) bits This bitfield holds a unique number for a dedicated device configuration (die).
16-13	TECH	0000 0001 0010 0011 Others	Process technology on which the device is manufactured. C05 F05 C035 F035 Reserved
12	I/O VOLTAGE	0 1	I/O voltage of the device. I/O are 3.3v I/O are 5v
11	PERIPHERAL PARITY	0 1	Peripheral Parity No parity on peripherals Parity on peripherals
10-9	FLASH ECC	00 01 10 11	Flash ECC No error detection/correction Program memory with parity Program memory with ECC Reserved
8	RAM ECC	0 1	Indicates if RAM memory ECC is present. No ECC implemented ECC implemented
7-3	REVISION		Revision of the Device.

Table 5-1. Device ID Bit Allocation Register Field Descriptions (continued)

Bit	Field	Value	Description
2-0	101		The platform family ID is always 0b101

5.2 Die-ID Registers

The two registers (DIEIDL and DIEIDH) form a 64-bit number that contains information about the device's die lot number, wafer number and X, Y wafer coordinates. The die identification information will vary from unit to unit. This information is programmed by TI as part of the initial device test procedure. The data format of the Die-ID registers is shown here.

Figure 5-2. DIEIDL Register (Location: 0xFFFF FF7C)

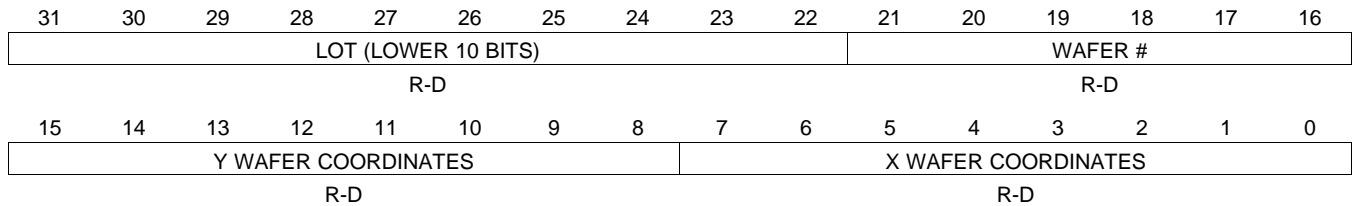

LEGEND: R/W = Read/Write; R = Read only; -n = value after reset; D= *device dependent*

Figure 5-3. DIEIDH Register (Location: 0xFFFF FF80)

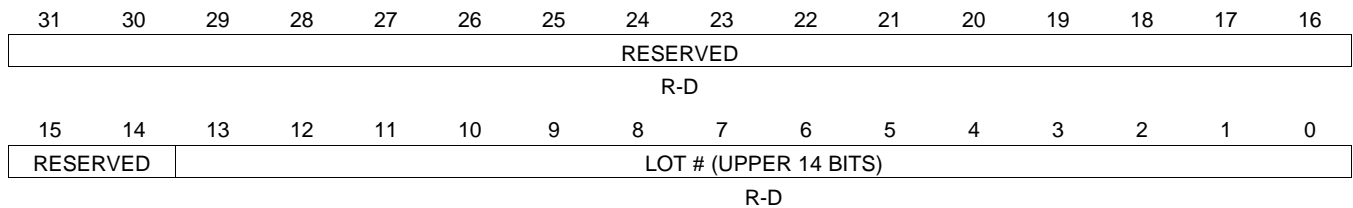

LEGEND: R/W = Read/Write; R = Read only; -n = value after reset; D= *device dependent*

5.3 PLL Registers

The default values for the PLL (Phase Locked Loop) control registers are shown in this section. PLLCTL1 and PLLCTL2 are used to configure PLL1 (F035 FMzPLL) and PLLCTL3 is used to configure PLL2 (F035 FPLL).

Figure 5-4. PLLCTL1 Register (Location: 0xFFFF FF70)

31	30	29	28	27	26	25	24	23	22	21	20	19	18	17	16
ROS	BPOS[1:0]		PLLDIV[4:0]				ROF	RESV	REFCLKDIV[5:0]						
R/WP-0	R/WP-01		R/WP-01111				R/WP-0	R-0	R/WP-000010						
15	14	13	12	11	10	9	8	7	6	5	4	3	2	1	0
PLLMUL[15:0]															
R/WP-0101111100000000															

LEGEND: R/W = Read/Write; R = Read only; -n = value after reset; D= device specific
 PLLCTL1 Default = 0x2F025F00

Figure 5-5. PLLCTL2 Register (Location: 0xFFFF FF74)

31	30	29	28	27	26	25	24	23	22	21	20	19	18	17	16	
FMENA	SPREADINGRATE[8:0]								RESV	EWADJ[8:4]						
R/WP-0	R/WP-111111111								R-0	R/WP-00000						
15	14	13	12	11	10	9	8	7	6	5	4	3	2	1	0	
BWADJ[3:0]			ODPLL			SPR_AMOUNT[8:0]										
R/WP-0111			R/WP-001			R/WP-000000000										

LEGEND: R/W = Read/Write; R = Read only; -n = value after reset; D = device specific
 PLLCTL2 Default = 0x7FC07200

NOTE

There are several combinations of the modulation depth and modulation frequency that are not allowed. Valid settings for this device include the list in [Table 7-2](#).

Figure 5-6. PLLCTL3 Register (Location: 0xFFFF E100)

31	30	29	28	27	26	25	24	23	22	21	20	19	18	17	16	
RESERVED									OSC DIV	RESERVED						
R/W-000000000									R/WP-0	R/W-000000						
15	14	13	12	11	10	9	8	7	6	5	4	3	2	1	0	
RESERVED			PLL_MUL[3:0]			RESERVED			PLL_DIV [2:0]							
R/W-000000			R/WP-011			R/W-00000			R/WP 111							

LEGEND: R/W = Read/Write; R = Read only; -n = value after reset; D= device specific
 PLLCTL3 Default = 0x00000307

6 Device Electrical Specifications

6.1 Operating Conditions

6.2 Absolute Maximum Ratings Over Operating Free-Air Temperature Range (unless otherwise noted)⁽¹⁾

Supply voltage ranges	V_{CC} ⁽²⁾	- 0.3 V to 2.1V
	V_{CCIO} , V_{CCAD} , V_{CCP} (Flash pump) ⁽²⁾	- 0.3 V to 4.1V
Input voltage range	All input pins	- 0.3 V to 4.1 V
Input clamp current	$I_{IK}(V_I < 0 \text{ or } V_I > V_{CCIO})$	±20 mA
	All pins except AD1IN[7:0], AD2IN[7:0], ADSIN[15:8]	
	$I_{IK}(V_I < 0 \text{ or } V_I > V_{CCAD})$	
	AD1IN[7:0], AD2IN[7:0], ADSIN[15:8]	±10 mA
	total	±40 mA
Operating free-air temperature ranges, T_A		-55°C to 125°C
Storage temperature range, T_{stg}		-65°C to 150°C

- (1) Stresses beyond those listed under “absolute maximum ratings” may cause permanent damage to the device. These are stress ratings only, and functional operation of the device at these or any other conditions beyond those indicated under “recommended operating conditions” is not implied. Exposure to absolute-maximum-rated conditions for extended periods may affect device reliability
- (2) All voltage values are with respect to their associated grounds.

6.3 Device Recommended Operating Conditions⁽¹⁾

		MIN	NOM	MAX	Unit
V_{CC}	Digital logic supply voltage (Core)	1.35	1.5	1.65	V
V_{CCIO}	Digital logic supply voltage (I/O)	3	3.3	3.6	V
V_{CCAD}	MibADC supply voltage	3	3.3	3.6	V
V_{CCP}	Flash pump supply voltage	3	3.3	3.6	V
V_{SS}	Digital logic supply ground		0		V
V_{SSAD}	MibADC supply ground	-0.1		0.1	V
T_A	Operating free-air temperature	-55		125	°C

- (1) All voltages are with respect to V_{SS} except V_{CCAD} is with respect to V_{SSAD} .

6.4 Thermal Information

THERMAL METRIC		TMS570LS20206 TMS570LS20216		UNITS
		GWT	PGE	
		337 BALL	144 PINS	
θ_{JA}	Junction-to-ambient thermal resistance ⁽¹⁾	30.7	32.1	°C/W
θ_{JCTop}	Junction-to-case (top) thermal resistance ⁽²⁾	4.7	3.3	
θ_{JB}	Junction-to-board thermal resistance ⁽³⁾	15	13.7	
ψ_{JT}	Junction-to-top characterization parameter ⁽⁴⁾	0.1	0.1	
ψ_{JB}	Junction-to-board characterization parameter ⁽⁵⁾	15	13.3	
θ_{JCbott}	Junction-to-case (bottom) thermal resistance ⁽⁶⁾	N/A	N/A	

- (1) 在 JESD51-2a 描述的环境中，按照 JESD51-7 的规定，在一个 JEDEC 标准高 K 电路板上进行仿真，从而获得自然对流条件下的结至环境热阻抗。
- (2) 通过在封装顶部模拟一个冷板测试来获得结至芯片外壳（顶部）的热阻。不存在特定的 JEDEC 标准测试，但可在 ANSI SEMI 标准 G30-88 中找到内容接近的说明。
- (3) 按照 JESD51-8 中的说明，通过在配有用于控制 PCB 温度的环形冷板夹具的环境中进行仿真，以获得结至电路板的热阻。
- (4) 结至顶部的特征参数，(ψ_{JT})，估算真实系统中器件的结温，并使用 JESD51-2a（第 6 章和第 7 章）中描述的程序从仿真数据中提取出该参数以便获得 θ_{JA} 。
- (5) 结至电路板的特征参数，(ψ_{JB})，估算真实系统中器件的结温，并使用 JESD51-2a（第 6 章和第 7 章）中描述的程序从仿真数据中提取出该参数以便获得 θ_{JA} 。
- (6) 通过在外露（电源）焊盘上进行冷板测试仿真来获得结至芯片外壳（底部）热阻。不存在特定的 JEDEC 标准测试，但可在 ANSI SEMI 标准 G30-88 中找到了内容接近的说明。

6.5 Electrical Characteristics Over Operating Free-Air Temperature Range⁽¹⁾

Parameter			Test Conditions	MIN	TYP	MAX	Unit	
V _{hys}	Input hysteresis			0.15			V	
V _{IL}	Low-level input voltage	All inputs ⁽²⁾		-0.3		0.8	V	
V _{IH}	High-level input voltage	All inputs		2		V _{CCIO} + 0.3	V	
V _{OL}	Low-level output voltage		I _{OL} = I _{OL} MAX			0.2 V _{CCIO}	V	
			I _{OL} = 50 μA			0.2		
V _{OH}	High-level output voltage		I _{OH} = I _{OH} MAX	0.8 V _{CCIO}			V	
			I _{OH} = 50 μA	V _{CCIO} - 0.2				
V _{ILoscIn}	Low-level input voltage	OSCIN		-0.3		0.2 V _{CC}	V	
V _{IHoscIn}	High-level input voltage	OSCIN		0.8 V _{CC}		V _{CC} + 0.3	V	
V _{MON}	Voltage monitoring threshold		VCC low	1.0	1.2	1.35	V	
			VCC high	1.7	2	2.38		
			VCCIO low	2.0	2.4	3.0		
I _{IC}	Input clamp current		V _I < V _{SSIO} - 0.3 or V _I > V _{CCIO} + 0.3	-2		2	mA	
I _I	Input current (I/O pins)		I _{IL} Pulldown	V _I = V _{SS}	-1		1	μA
			I _{IH} Pulldown 20 uA	V _I = V _{CCIO}	5		40	
			I _{IH} Pulldown 100 uA	V _I = V _{CCIO}	40		195	
			I _{IL} Pullup 20 uA	V _I = V _{SS}	-40		-3.6	
			I _{IL} Pullup 100 uA	V _I = V _{SS}	-195		-40	
			I _{IH} Pullup	V _I = V _{CCIO}	-1		1	
			All other pins	No pullup or pulldown	-1		1	
I _{OL}	Low-level output current		TDO	V _{OL} = V _{OL} MAX			8	mA
			TDI					
			TMS					
			RTCK					
			ECLK					
			FRAYTX1					
			FRAYTXEN1					
			FRAYTX2					
			FRAYTXEN2					
			$\overline{\text{DMMENA}}$					
			ETMTRACECTL					
			ETMTRACECLKOUT					
			ETMDATA[31:0]					
			RTPSYNC					
			RTPCLK					
			RTPDATA[15:0]					
			$\overline{\text{EMIFWE}}$					
			$\overline{\text{EMIFOE}}$					
			$\overline{\text{EMIFCS}}[3:0]$					
			EMIFDATA[15:0]					
EMIFADD[21:0]								
EMIFBADD[1:0]								
$\overline{\text{EMIFDQM}}[1:0]$								
$\overline{\text{ERROR}}$								

(1) Source currents (out of the device) are negative while sink currents (into the device) are positive.

(2) This does not apply to PORRST pin.

Electrical Characteristics Over Operating Free-Air Temperature Range⁽¹⁾ (continued)

Parameter		Test Conditions	MIN	TYP	MAX	Unit
I _{OL}	Low-level output current	\overline{RST} MIBSPI1CLK MIBSPI1SIMO MIBSPI1SOMI MIBSPI3CLK MIBSPI3SIMO MIBSPI3SOMI MIBSPI5CLK MIBSPI5SIMO[3:0] MIBSPI5SOMI[3:0] DMMDATA[15:8] DMMDATA[4]	V _{OL} = V _{OL} MAX		4	mA
		All other output pins			2	
I _{OH}	High-level output current	TDO TDI TMS RTCK ECLK FRAYRX1 FRAYTX1 FRAYTXEN1 FRAYRX2 FRAYTX2 FRAYTXEN2 ETMTRACECTL ETMTRACECLKOUT ETMDATA[31:0] RTPSYNC RTPCLK RTPDATA[15:0] \overline{DMMENA} \overline{EMIFWE} \overline{EMIFOE} \overline{EMIFCS} [3:0] EMIFDATA[15:0] EMIFADD[21:0] EMIFBADD[1:0] $\overline{EMIFDQM}$ [1:0] \overline{ERROR}	V _{OH} = V _{OH} MIN		-8	mA

Electrical Characteristics Over Operating Free-Air Temperature Range⁽¹⁾ (continued)

Parameter		Test Conditions	MIN	TYP	MAX	Unit
I _{OH}	High-level output current	RST MIBSPI1CLK MIBSPI1SIMO MIBSPI1SOMI MIBSPI3CLK MIBSPI3SIMO MIBSPI3SOMI MIBSPI5CLK MIBSPI5SIMO[3:0] MIBSPI5SOMI[3:0] DMMDATA[15:8] DMMDATA[4]	V _{OH} = V _{OH} MIN		-4	mA
		All other output pins			-2	
I _{CC} ⁽¹⁾	V _{CC} Digital supply current (Operating mode)	All packages	HCLK = 100MHz, VCLK = 100MHz		350	mA
			HCLK = 140MHz, VCLK = 70MHz		390	
		BGA packages	HCLK = 160MHz, VCLK = 80MHz		430	
	V _{CC} Digital supply current (CPU selftest mode: LBIST) ⁽²⁾⁽³⁾	All packages	STCCLK = 46.666MHz	Peak	510	mA
			STCCLK = 50.0MHz	Peak	540	
		BGA packages	STCCLK = 53.333MHz	Peak	580	mA
	V _{CC} Digital supply current (Mem selftest mode: PBIST) ⁽²⁾⁽⁴⁾	All packages	HCLK=80MHz, VCLK=40MHz	Peak	340	
			HCLK=100MHz, VLCK=100MHz	Peak	430	
	V _{CC} Digital supply current (doze mode)		OSCIN = 6 MHz, V _{CC} = 1.65 V ⁽⁵⁾		35	mA
	V _{CC} Digital supply current (snooze mode)		All frequencies, V _{CC} = 1.65 V ⁽⁵⁾		30	
V _{CC} Digital supply current (sleep mode)		All frequencies, V _{CC} = 1.65 V ⁽⁵⁾		25		
I _{CCIO}	V _{CCIO} Digital supply current (operating mode)		No DC load, V _{CCIO} = 3.6 V ⁽⁶⁾		15	mA
	V _{CCIO} Digital supply current (doze mode)		No DC load, V _{CCIO} = 3.6 V ⁽⁶⁾		700	
	V _{CCIO} Digital supply current (snooze mode)		No DC load, V _{CCIO} = 3.6 V ⁽⁶⁾		100	
	V _{CCIO} Digital supply current (sleep mode)		No DC load, V _{CCIO} = 3.6 V ⁽⁶⁾		100	
I _{CCAD}	V _{CCAD} supply current (operating mode)		All frequencies, V _{CCAD} = 3.6 V		30	mA
	V _{CCAD} supply current (doze mode)		All frequencies, V _{CCAD} = 3.6 V ⁽⁵⁾		200	
	V _{CCAD} supply current (snooze mode)		All frequencies, V _{CCAD} = 3.6 V ⁽⁵⁾		200	
	V _{CCAD} supply current (sleep mode)		All frequencies, V _{CCAD} = 3.6 V ⁽⁵⁾		200	
I _{CCP}	V _{CCP} pump supply current		V _{CCP} = 3.6 V read operation		25	mA
			V _{CCP} = 3.6 V program ⁽⁷⁾		90	
			V _{CCP} = 3.6 V erase		90	
			V _{CCP} = 3.6 V doze mode ⁽⁵⁾		5	
			V _{CCP} = 3.6 V snooze mode ⁽⁵⁾		5	
			V _{CCP} = 3.6 V sleep mode ⁽⁵⁾		5	
C _I	Input capacitance ⁽⁸⁾				2	pF
C _O	Output capacitance				3	pF

(1) Typical values are at V_{CC}=1.5V and maximum values are at V_{CC}=1.65V

(2) The peak current is measured on the TI EVM board with two 10μF and thirteen 100nF capacitors on VCC domain. Running at a lower frequency consumes less current.

(3) LBIST currents specified are for execution of LBIST with a certain STC clock. Lower current consumption can be achieved by configuring a slower STC Clock frequency. The current peak duration can last for the duration of 1 LBIST test interval.

(4) PBIST currents specified are for execution of PBIST on all RAMs(Group 1- 14) and all the algorithms. Lower current consumption can be achieved by configuring a slower HCLK frequency. Different algorithms consume different current. For more information, please refer to *Basic PBIST Configuration and influence on current consumption (SPNA128)*.

(5) For Flash banks/pumps in sleep mode.

(6) I/O pins configured as inputs or outputs with no load. All pulldown inputs ≤ 0.2 V. All pullup inputs ≥ V_{CCIO} - 0.2 V.

(7) This assumes reading from one bank while programming a different bank.

(8) The maximum input capacitance C_I of the FlexRay RX pin(s) is 10pF.

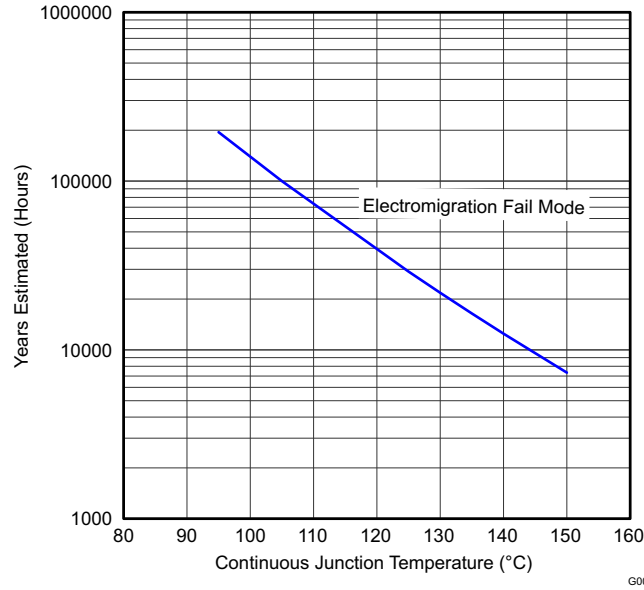

- (1) See the absolute maximum ratings and the recommended operating conditions.
- (2) Silicon operating life design goal is 10 years at 105°C junction temperature (does not include package interconnect life).
- (3) The predicted operating lifetime vs junction temperature is based on reliability modeling using electromigration as the dominant failure mechanism affecting device wearout for the specific device process and design characteristics.

Figure 6-1. TMS570LS20206-EP and TMS570LS20216-EP Operating Life Derating Chart

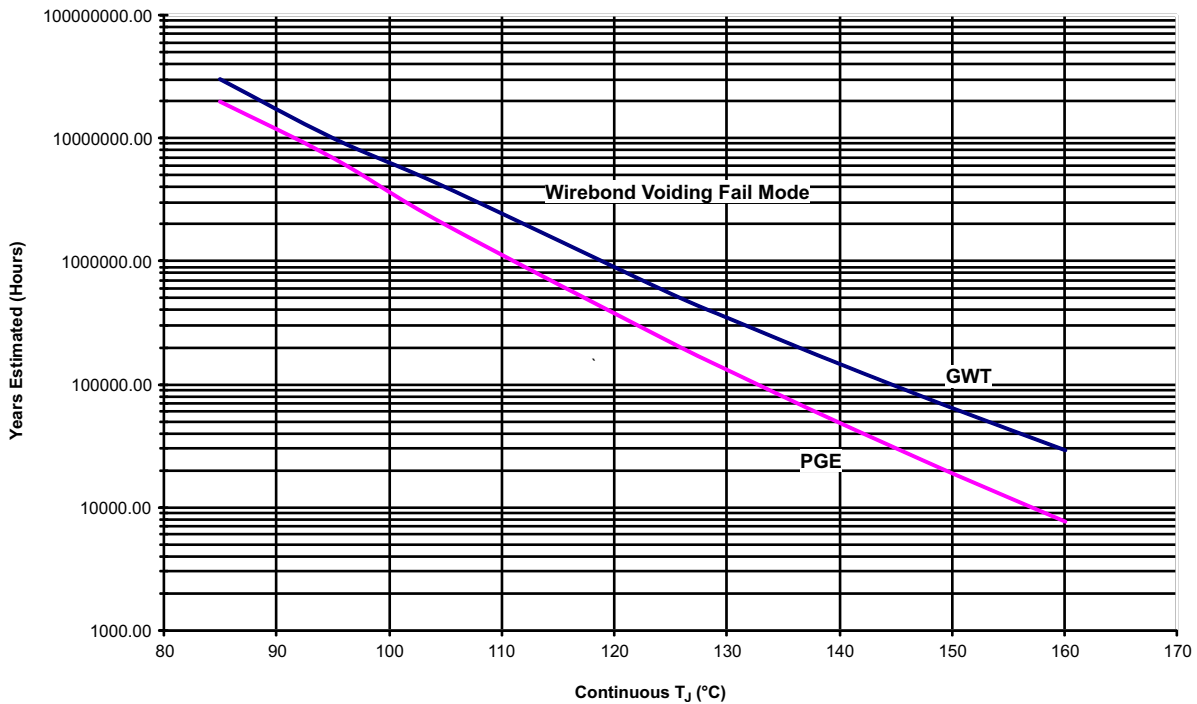

Figure 6-2. TMS570LS20206-EP and TMS570LS20216-EP Wirebond Voiding Fail Mode

7 Peripheral and Electrical Specifications

7.1 Clocks

7.1.1 PLL And Clock Specifications

Table 7-1. Timing Requirements For PLL Circuits Enabled Or Disabled

		MIN	MAX	Unit
$f_{(OSC)}^{(1)}$	Input clock frequency	5		MHz
$f_{(OSC)}$	Input clock frequency		20	MHz
$t_{c(OSC)}$	Cycle time, OSCIN	50		ns
$t_{w(OSCIL)}$	Pulse duration, OSCIN low	15		ns
$t_{w(OSCIH)}$	Pulse duration, OSCIN high	15		ns
$f_{(OSCRST)}^{(1)}$	OSC FAIL frequency - upper level	20	50	MHz
$f_{(OSCRST)}^{(1)}$	OSC FAIL frequency - lower level	1.5	5	MHz

(1) This parameter is characterized from -40°C to 125°C only.

7.1.2 External Reference Resonator/Crystal Oscillator Clock Option

The oscillator is enabled by connecting the appropriate fundamental 5–20 MHz resonator/crystal and load capacitors across the external OSCIN and OSCOUT pins as shown in section (a) of the figure below. The oscillator is a single stage inverter held in bias by an integrated bias resistor. This resistor is disabled during leakage test measurement and HALT mode.

NOTE

TI strongly encourages each customer to submit samples of the device to the resonator/crystal vendors for validation. The vendors are equipped to determine what load capacitors will best tune their resonator/crystal to the microcontroller device for optimum start-up and operation over temperature/voltage extremes.

An external oscillator source can be used by connecting a 1.5V clock signal to the OSCIN pin and leaving the OSCOUT pin unconnected (open) as shown in section (b) of the figure below.

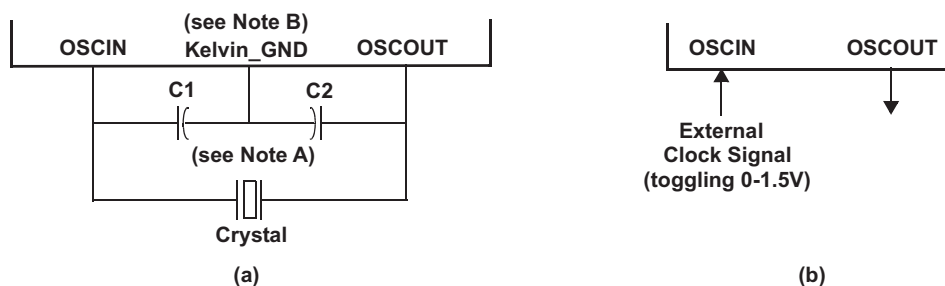
Figure 7-1. Recommended Crystal/Clock Connection

NOTE

In figure (a), The values of C1 and C2 should be provided by the resonator/crystal vendor.

In figure (b), Kelvin_GND should not be connected to any other GND.

7.1.3 Validated FMPLL Setting

The following table includes the validated FMPLL settings.

Table 7-2. Validated FMPLL Settings

OSC_IN Frequency (MHz)	PLLCTL1	PLLCTL2	FMPLL Output Frequency(MHz)	Modulation Bandwidth (KHz)	Modulation Depth
10	0x20049500	0x82409253	150	100	0.5%
10	0x20049500	0x8300B240	150	77	0.5%
10	0x20048600	0x8240925C	135	100	0.5%
10	0x20048600	0x8300B247	135	77	0.5%
10	0x20048600	0x824092B9	135	100	1.0%
10	0x20048D80	0x8300B443	95	77	0.5%
10	0x20048D80	0x824094AF	95	100	1.0%
16	0x20079500	0x82409253	150	100	0.5%
16	0x20079500	0x8300B240	150	77	0.5%
16	0x20078600	0x8240925C	135	100	0.5%
16	0x20078600	0x8300B247	135	77	0.5%
16	0x20078600	0x824092B9	135	100	1.0%
16	0x20078D80	0x8300B443	95	77	0.5%
16	0x20078D80	0x824094AF	95	100	1.0%
20	0x20099500	0x82409253	150	100	0.5%
20	0x20099500	0x8300B240	150	77	0.5%
20	0x20098600	0x8240925C	135	100	0.5%
20	0x20098600	0x8300B247	135	77	0.5%
20	0x20098600	0x824092B9	135	100	1.0%
20	0x20098D80	0x8300B443	95	77	0.5%
20	0x20098D80	0x824094AF	95	100	1.0%

7.1.4 LPO And Clock Detection

The LPOCLKDET module consists of a clock monitor (CLKDET) and 2 low power oscillators (LPO) - a low frequency (LF) and a high frequency (HF) oscillator. The CLKDET is a supervisor circuit for an externally supplied clock signal. In case the externally supplied clock frequency falls out of a frequency window, the clock detector flags this condition and switches to the HF LPO clock (limp mode). The OSCFAIL flag and clock switch-over remain, regardless of the behavior of the oscillator clock signal. The only way OSCFAIL can be cleared (and re-enable OSCIN as the clock source) is a power-on-reset.

Table 7-3. LPO And Clock Detection

Parameter		MIN	Type	MAX	Unit
Invalid frequency	lower threshold	1.5		5	MHz
	upper threshold	20		50	MHz
Limp mode frequency (HFosc)		7.9	10	14.4	MHz
HFosc frequency		7.9	10	14.4	MHz
LFosc frequency		62	80	113	kHz

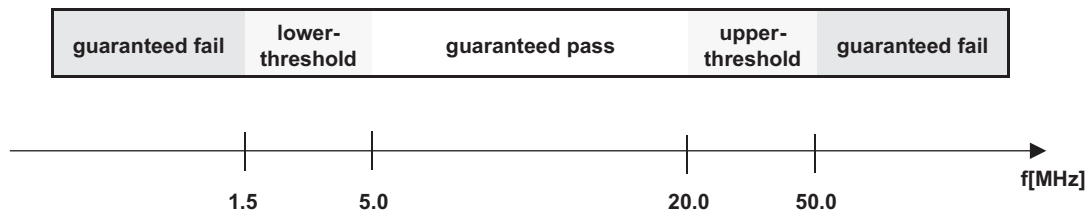

Figure 7-2. LPO And Clock Detection

7.1.5 Switching Characteristics Over Recommended Operating Conditions For Clocks

Table 7-4. Switching Characteristics Over Recommended Operating Conditions For Clocks

Parameter	Test Conditions	MIN	MAX	Unit
f _(HCLK)	HCLK - System clock frequency (337 BGA packages)	Pipeline mode enabled	160	MHz
		Pipeline mode disabled	36	MHz
f _(HCLK)	HCLK - System clock frequency (144pin QFP package)	Pipeline mode enabled	140	MHz
		Pipeline mode disabled	36	MHz
f _(GCLK)	GCLK - CPU clock frequency (ratio GCLK : HCLK = 1:1)		f _(HCLK)	MHz
f _(RCLK)	RCLK - Frequency out of PLL macro into R-divider		160	MHz
f _(RTICK) ⁽¹⁾	RTICK - clock frequency		f _(VCLK)	MHz
f _(VCLK)	VCLK - Primary peripheral clock frequency		f _(VCLK2)	MHz
f _(VCLK2)	VCLK2 - Secondary peripheral clock frequency		100	MHz
f _(AVCLK1)	AVCLK1 - Primary asynchronous peripheral clock frequency		f _(VCLK)	MHz
f _(AVCLK2)	AVCLK2 - Secondary asynchronous peripheral clock frequency		f _(VCLK)	MHz
f _(ECLK) ⁽²⁾	ECLK - External clock output frequency for ECP Module		80	MHz
f _(PROG/ERASE)	System clock frequency - Flash programming/erase		f _(HCLK)	MHz

- (1) If the RTIx clock source is chosen to be anything other than the default VCLK, then the RTI clock needs to be at least three times slower than the VCLK.
- (2) (ECLK) = f(VCLK) / N, where N = {1 to 65536}. N is the ECP prescale value defined by the ECPCNTL.[15:0] register bits in the System module. Pipeline mode enabled or disabled is determined by the FRDCNTL[2:0].

7.1.5.1 Timing - Wait States

RAM

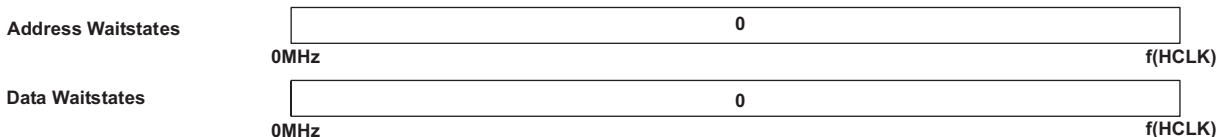

Flash



Figure 7-3. Wait States

NOTE

If FMzPLL frequency modulation is enabled, special care must be taken to ensure that the maximum system clock frequency f(HCLK) and peripheral clock frequency f(VCLK) are not exceeded. The speed of the device clocks may need to be derated to accommodate the modulation depth when FMzPLL frequency modulation is enabled.

7.2 ECLK Specification

7.2.1 Switching Characteristics Over Recommended Operating Conditions For External Clocks

Table 7-5. Switching Characteristics Over Recommended Operating Conditions For External Clocks⁽¹⁾⁽²⁾

NO.	Parameter		Test Conditions	MIN	MAX	Unit
3	$t_{w(EOL)}$	Pulse duration, ECLK low	under all prescale factor combinations (X and N)	$0.5t_{c(ECLK)} - t_f$		ns
4	$t_{w(EOH)}$	Pulse duration, ECLK high	under all prescale factor combinations (X and N)	$0.5t_{c(ECLK)} - t_r$		ns

(1) X = {1,2,3,4,5,6,7,8,9,10,11,12,13,14,15,16}. X is the VBUS interface clock divider ratio determined by the CLKCNTL.[19:16] bits in the SYS module.

(2) N = {1 to 65536}. N is the ECP prescale value defined by the ECPCNTL.[15:0] register bits in the System module.

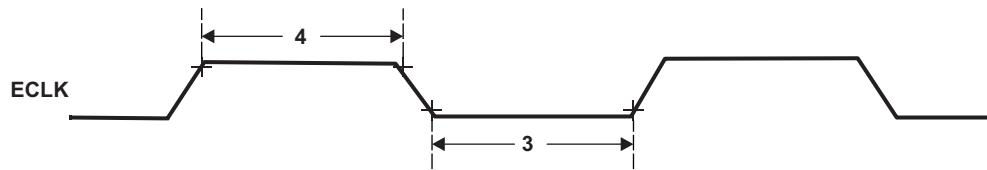

Figure 7-4. ECLK Timing Diagram

7.3 RST And PORRST Timings

7.3.1 Timing Requirements For PORRST

Table 7-6. Timing Requirements For PORRST

NO.			MIN	MAX	Unit
	$V_{CCPORL}^{(1)}$	V_{CC} low supply level when \overline{PORRST} must be active during power up		0.5	V
	$V_{CCPORH}^{(1)}$	V_{CC} high supply level when \overline{PORRST} must remain active during power up and become active during power down	1.35		V
	$V_{CCIOPORL}^{(1)}$	V_{CCIO} / V_{CCP} low supply level when \overline{PORRST} must be active during power up		1.1	V
	$V_{CCIOPORH}^{(1)}$	V_{CCIO} / V_{CCP} high supply level when \overline{PORRST} must remain active during power up and become active during power down	3		V
	$V_{IL(PORRST)}^{(1)}$	Low-level input voltage of \overline{PORRST} $V_{CCIO} > 2.5V$		$0.2 V_{CCIO}$	V
		Low-level input voltage of \overline{PORRST} $V_{CCIO} < 2.5V$		0.5	V
3	$t_{su(PORRST)}^{(1)}$	Setup time, \overline{PORRST} active before V_{CCIO} and $V_{CCP} > V_{CCIOPORL}$ during power up	0		ms
6	$t_h(PORRST)^{(1)}$	Hold time, \overline{PORRST} active after $V_{CC} > V_{CCPORH}$	1		ms
7	$t_{su(PORRST)}^{(1)}$	Setup time, \overline{PORRST} active before $V_{CC} \leq V_{CCPORH}$ during power down	8		μs
8	$t_h(PORRST)^{(1)}$	Hold time, \overline{PORRST} active after V_{CCIO} and $V_{CCP} > V_{CCIOPORH}$	1		ms
9	$t_h(PORRST)^{(1)}$	Hold time, \overline{PORRST} active after $V_{CC} < V_{CCPORL}$	0		ms
	$t_f(PORRST)^{(1)}$	Filter time \overline{PORRST} , pulses less than MIN will be filtered out, pulses greater than MAX are guaranteed to generate a reset ⁽²⁾	20	150	ns
	$t_f(RST)$	Filter time \overline{RST} , pulses less than MIN will be filtered out, pulses greater than MAX are guaranteed to generate a reset	20	150	ns

(1) This parameter is characterized from -40°C to 125°C only.

(2) A low pulse on the nPORRST pin which is just barely longer than the glitch filter implemented on this pin will result in a very short internal reset. This may result in unpredictable behavior as some parts of the device may be reset while other parts of the device are not.

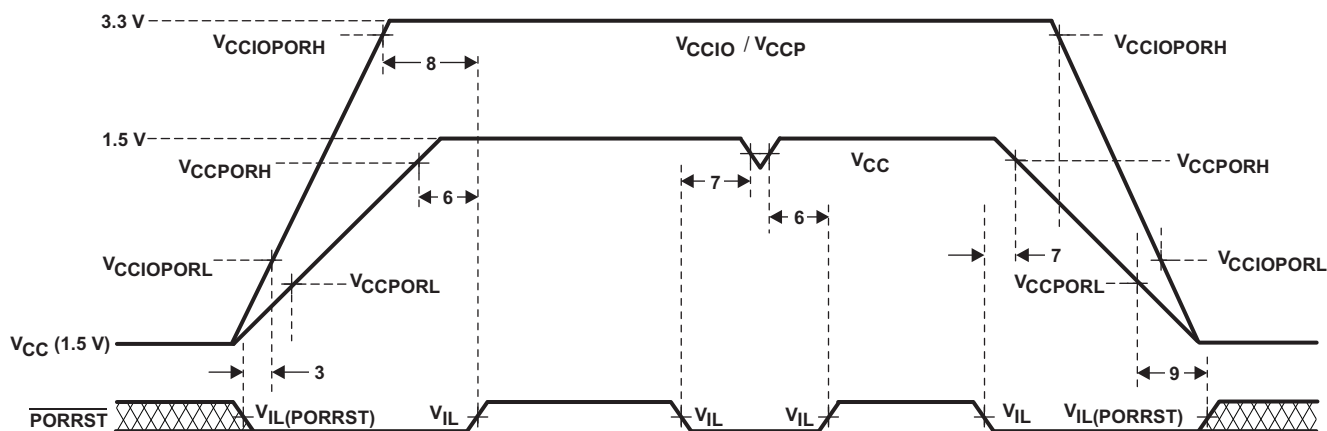

Figure 7-5. PORRST Timing Diagram

NOTE

There is no timing dependency between the ramp of the VCCIO and the VCC supply voltage; this is just an exemplary drawing. All requirements are to ensure \overline{PORRST} is active when VCCIO or VCC is out of the normal operating range.

7.3.2 Switching Characteristics Over Recommended Operating Conditions For \overline{RST}

Table 7-7. Switching Characteristics Over Recommended Operating Conditions For \overline{RST} ⁽¹⁾⁽²⁾

	Parameter	MIN	MAX	Unit
$t_{v(RST)}$	Valid time, \overline{RST} active after \overline{PORRST} inactive	1048 _{c(OSC)}		ns
	Valid time, \overline{RST} active (all others)	8 _{t_c(VCLK)}		

- (1) Specified values do NOT include rise/fall times. For rise and fall timings, see the switching characteristics for output timings versus load capacitance table.
- (2) This parameter is characterized from -40°C to 125°C only.

7.3.3 IO Status During \overline{PORRST}

IO buffer condition during power-on-reset (nPORRST is low): All I/O pins, except nRST, are configured as High-impedance while nPORRST is low and immediately after nPORRST goes high. The FlexRay FRAYTX1 and FRAYTX2 pins are high impedance (high-Z) while nPORRST is low, and are output high at latest 1024 oscillator cycles after nPORRST goes high; the FlexRay FRAYTXEN1 and FRAYTXEN2 pins are high impedance (high-Z) while nPORRST is low, and output high immediately after nPORRST goes high.

IO pullup/pulldown condition during power-on-reset: all internal pullups and pulldowns on input pins are disabled when nPORRST is low, and become active immediately after nPORRST goes high. Pins that are listed with "programmable" have programmable pullups or pulldowns. The default value after reset is listed underneath "programmable" in the following table. The exceptions are nPORRST, nRST, nTRST and TEST pins. The pulls on these pins will be active during power-on-reset.

7.4 TEST Pin Timing

Table 7-8. TEST Pin Timing⁽¹⁾

NO.		Description	MIN	MAX	Unit
	$t_{f(\text{TEST})}$	Filter time TEST, pulses less than MIN will be filtered out, pulses greater than MAX are guaranteed to enter TEST mode	10	80	ns

(1) This parameter is characterized from -40°C to 125°C only.

7.5 DAP - JTAG Scan Interface Timing

7.5.1 JTAG clock specification 12-MHz and 50-pF load on TDO output

Table 7-9. JTAG Scan Interface Timing

NO.			MIN	MAX	Unit
	$f_{(TCK)}$	TCK frequency (at HCLKmax)		12	MHz
	$f_{(RTCK)}$	RTCK frequency (at TCKmax and HCLKmax)	10		MHz
1	$t_{d(TCK-RTCK)}$	Delay time, TCK to RTCK		20	ns
2	$t_{su(TDI/TMS-RTCKr)}$	Setup time, TDI, TMS before RTCK rise (RTCKr)	15		ns
3	$t_{h(RTCKr-TDI/TMS)}$	Hold time, TDI, TMS after RTCKr	0		ns
4	$t_{h(RTCKf-TDO)}$	Hold time, TDO after RTCKf	0		ns
5	$t_{d(RTCKf-TDO)}$	Delay time, TDO valid after RTCK fall (RTCKf)		10	ns

Note: The timings in this table are measured with a 50pF and 50μA load. And they are measured at the 50% point, not 20% or 80% point.

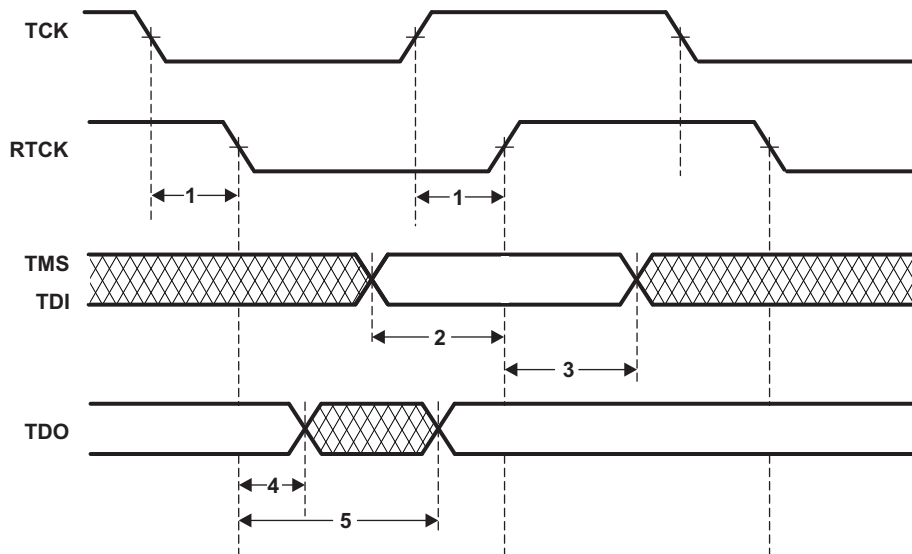
Figure 7-6. JTAG timing

7.6 Output Timings

7.6.1 Switching Characteristics For Output Timings Versus Load Capacitance (C_L)

Table 7-10. Switching Characteristics For Output Timings Versus Load Capacitance (C_L)

Parameter		MIN	TYP	MAX	Unit
t_r	8mA pins	$C_L = 15 \text{ pF}$	2.5		ns
		$C_L = 50 \text{ pF}$	5		
		$C_L = 100 \text{ pF}$	9		
		$C_L = 150 \text{ pF}$	12		
t_f	8mA pins	$C_L = 15 \text{ pF}$	2.5		ns
		$C_L = 50 \text{ pF}$	5		
		$C_L = 100 \text{ pF}$	9		
		$C_L = 150 \text{ pF}$	12		
t_r	4mA pins	$C_L = 15 \text{ pF}$	7		ns
		$C_L = 50 \text{ pF}$	13		
		$C_L = 100 \text{ pF}$	21		
		$C_L = 150 \text{ pF}$	29		
t_f	4mA pins	$C_L = 15 \text{ pF}$	7		ns
		$C_L = 50 \text{ pF}$	13		
		$C_L = 100 \text{ pF}$	21		
		$C_L = 150 \text{ pF}$	29		
t_r	2mA-z pins	$C_L = 15 \text{ pF}$	10		ns
		$C_L = 50 \text{ pF}$	17		
		$C_L = 100 \text{ pF}$	25		
		$C_L = 150 \text{ pF}$	35		
t_f	2mA-z pins	$C_L = 15 \text{ pF}$	10		ns
		$C_L = 50 \text{ pF}$	17		
		$C_L = 100 \text{ pF}$	25		
		$C_L = 150 \text{ pF}$	35		

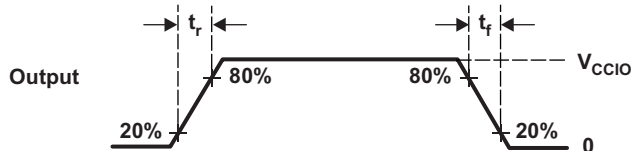

Figure 7-7. CMOS-Level Outputs

7.7 Input Timings

7.7.1 Timing Requirements For Input Timings

Table 7-11. Timing Requirements For Input Timings⁽¹⁾

		MIN	MAX	Unit
t_{pw}	Input minimum pulse width	$t_{c(VCLK)} + 10^{(2)}$		ns

- (1) $t_{c(VCLK)}$ = peripheral VBUS clock cycle time = $1 / f_{(VCLK)}$
 (2) The timing shown above is only valid for pin used in GIO mode

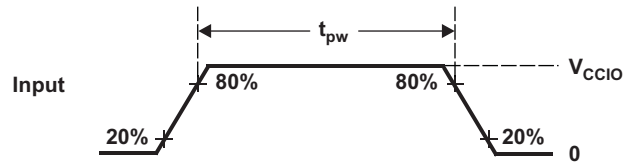

Figure 7-8. CMOS-Level Inputs

7.8 Flash Timings

Table 7-12. Timing Requirements For Program Flash

		MIN	NOM	MAX	Unit
$t_{\text{prog}(32\text{-bit})}$	Full word (32-bit) programming time		33	300	μs
$t_{\text{prog}(\text{Total})}$	2M-byte programming time ⁽¹⁾	-40°C to 125°C	17	74	s
		0°C to 60°C, for first 25 cycles	17	25	s
$t_{\text{prog ECC}(16\text{-bit})}$	ECC programming time		33	300	μs
$t_{\text{prog ECC}(\text{total})}$	Total ECC bit programming time (256k-byte)	-40°C to 125°C	4.3	15	s
		0°C to 60°C, for first 25 cycles	4.3	7	s
$t_{\text{erase}(\text{sector})}$	Sector erase time (including compaction)	-40°C to 125°C	2	15	s
		0°C to 60°C, for first 25 cycles	1.5	10	s
$t_{\text{erase}(\text{bank})}$	Bank erase time (including compaction), 0°C to 60°C, for first 25 cycles	Bank 0	7.5	20	s
		Bank 1	5.5	12	s
		Bank 2	5.5	12	s
		Bank 3	5.5	12	s
t_{wec}	Write/erase cycles at $T_A = -40$ to 125°C ⁽²⁾			1000	cycles
t_{ret}	Data Retention with continuous 150°C ⁽²⁾	1000			hours

- (1) This programming time includes overhead of state machine, but does not include data transfer time.
- (2) Flash write/erase cycles and data retention specifications are based on a validated implementation of the TI flash API. Non-TI flash API implementation is not supported. For detailed description see the *F035 Flash Validation Procedure (SPNA127)*. The flash memory cells are qualified for data retention greater than 1000 hours at 150°C . Data retention at reduced temperatures can be estimated based on an Arrhenius model with activation energy of 1 eV.

7.9 SPI Master Mode Timing Parameters

7.9.1 SPI Master Mode External Timing Parameters (CLOCK PHASE = 0, SPICLK = output, SPISIMO = output, and SPISOMI = input)

Table 7-13. SPI Master Mode External Timing Parameters⁽¹⁾⁽²⁾⁽³⁾

NO.			MIN	MAX	Unit
1	$t_{c(SPC)M}$	Cycle time, SPICLK ⁽⁴⁾	50	$256t_{c(VCLK)}$	ns
2 ⁽⁵⁾	$t_{w(SPCH)M}$	Pulse duration, SPICLK high (clock polarity = 0)	$0.5t_{c(SPC)M} - 3 - t_r$	$0.5t_{c(SPC)M} + 5$	ns
	$t_{w(SPCL)M}$	Pulse duration, SPICLK low (clock polarity = 1)	$0.5t_{c(SPC)M} - 3 - t_f$	$0.5t_{c(SPC)M} + 5$	
3 ⁽⁵⁾	$t_{w(SPCL)M}$	Pulse duration, SPICLK low (clock polarity = 0)	$0.5t_{c(SPC)M} - 3 - t_f$	$0.5t_{c(SPC)M} + 5$	ns
	$t_{w(SPCH)M}$	Pulse duration, SPICLK high (clock polarity = 1)	$0.5t_{c(SPC)M} - 3 - t_r$	$0.5t_{c(SPC)M} + 5$	
4 ⁽⁵⁾	$t_{d(SIMO-SPCL)M}$	Delay time, SPISIMO valid before SPICLK low (clock polarity = 0)	$0.5t_{c(SPC)M} - 10$		ns
	$t_{d(SIMO-SPCH)M}$	Delay time, SPISIMO valid before SPICLK high (clock polarity = 1)	$0.5t_{c(SPC)M} - 10$		
5 ⁽⁵⁾	$t_{v(SPCL-SIMO)M}$	Valid time, SPISIMO data valid after SPICLK low (clock polarity = 0)	$0.5t_{c(SPC)M} - t_{f(SPC)} - 7$		ns
	$t_{v(SPCH-SIMO)M}$	Valid time, SPISIMO data valid after SPICLK high (clock polarity = 1)	$0.5t_{c(SPC)M} - t_{r(SPC)} - 7$		
6 ⁽⁵⁾	$t_{su(SOMI-SPCL)M}$	Setup time, SPISOMI before SPICLK low (clock polarity = 0)	$t_{f(SPC)}$		ns
	$t_{su(SOMI-SPCH)M}$	Setup time, SPISOMI before SPICLK high (clock polarity = 1)	$t_{r(SPC)} + 4$		
7 ⁽⁵⁾	$t_{h(SPCL-SOMI)M}$	Hold time, SPISOMI data valid after SPICLK low (clock polarity = 0)	10		ns
	$t_{h(SPCH-SOMI)M}$	Hold time, SPISOMI data valid after SPICLK high (clock polarity = 1)	10		
8 ⁽⁶⁾	$t_{C2TDELAY}$	Setup time CS active until SPICLK high, assumes that SPInENA is low at t_{SPIENA} (clock polarity = 0)	$(C2TDELAY + CSHOLD + 2) * t_{c(VCLK)} - t_{f(SPICS)} + t_{r(SPC)} - 9$	$(C2TDELAY + CSHOLD + 2) * t_{c(VCLK)} - t_{f(SPICS)} + t_{r(SPC)} + 5$	ns
		Setup time CS active until SPICLK low, assumes that SPInENA is low at t_{SPIENA} (clock polarity = 1)	$(C2TDELAY + CSHOLD + 2) * t_{c(VCLK)} - t_{f(SPICS)} + t_{f(SPC)} - 9$	$(C2TDELAY + CSHOLD + 2) * t_{c(VCLK)} - t_{f(SPICS)} + t_{f(SPC)} + 5$	ns
9 ⁽⁶⁾	$t_{T2CDELAY}$	Hold time SPICLK low until CS inactive (clock polarity = 0)	$0.5 * t_{c(SPC)M} + T2CDELAY * t_{c(VCLK)} + t_{c(VCLK)} - t_{f(SPC)} + t_{r(SPICS)} - 5$	$0.5 * t_{c(SPC)M} + T2CDELAY * t_{c(VCLK)} + t_{c(VCLK)} - t_{f(SPC)} + t_{r(SPICS)} + 10$	ns
		Hold time SPICLK high until CS inactive (clock polarity = 1)	$0.5 * t_{c(SPC)M} + T2CDELAY * t_{c(VCLK)} + t_{c(VCLK)} - t_{r(SPC)} + t_{r(SPICS)} - 5$	$0.5 * t_{c(SPC)M} + T2CDELAY * t_{c(VCLK)} + t_{c(VCLK)} - t_{r(SPC)} + t_{r(SPICS)} + 10$	ns
10	t_{SPIENA}	SPIENAn Sample point	$C2TDELAY * t_{c(VCLK)} - t_{f(SPICS)} - 20$	$C2TDELAY * t_{c(VCLK)}$	ns
11	$t_{SPIENAW}^{(7)}$	SPIENAn Sample point from write to buffer		$(C2TDELAY + 2) * t_{c(VCLK)}$	ns

(1) The MASTER bit (SPIGCR1.0) is set and the CLOCK PHASE bit (SPIFMTx.16) is set.

(2) $t_{c(VCLK)}$ = interface clock cycle time = $1 / f(VCLK)$

(3) For rise and fall timings, see the "switching characteristics for output timings versus load capacitance" table.

(4) When the SPI is in Master mode, the following must be true:

For PS values from 1 to 255: $t_{c(SPC)M} \geq (PS + 1)t_{c(VCLK)} \geq 50$ ns, where PS is the prescale value set in the SPIFMTx.[15:8] register bits.

For PS values of 0: $t_{c(SPC)M} = 2t_{c(VCLK)} \geq 50$ ns. The external load on the SPICLK pin must be less than 60pF.

(5) The active edge of the SPICLK signal referenced is controlled by the CLOCK POLARITY bit (SPIFMTx.17).

(6) C2TDELAY and T2CDELAY are programmed in the SPIDELAY register

(7) Parameters characterized from -40°C to 125°C only.

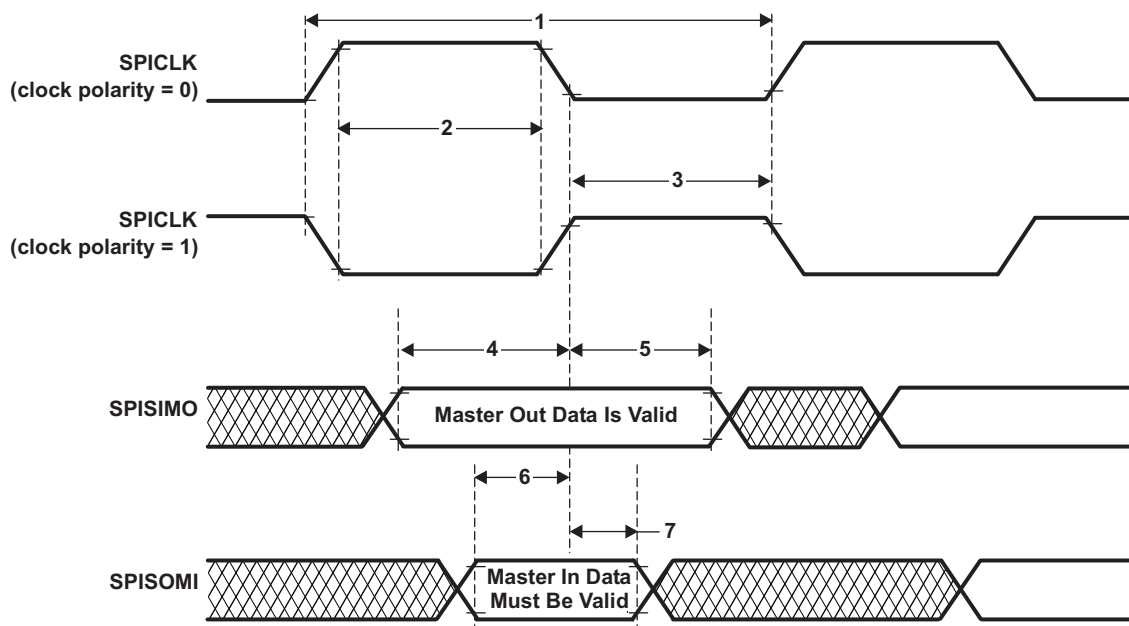

Figure 7-9. SPI Master Mode External Timing (CLOCK PHASE = 0)

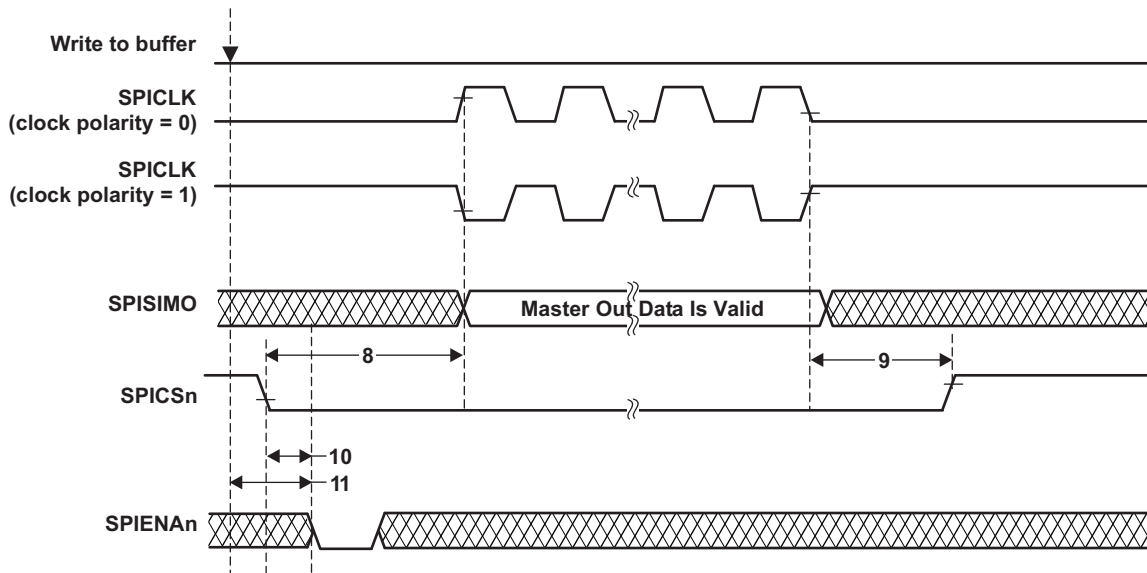

Figure 7-10. SPI Master Mode Chip Select timing (CLOCK PHASE = 0)

7.9.2 SPI Master Mode External Timing Parameters (CLOCK PHASE = 1, SPICLK = output, SPISIMO = output, and SPISOMI = input)
Table 7-14. SPI Master Mode External Timing Parameters⁽¹⁾⁽²⁾⁽³⁾

NO.			MIN	MAX	Unit
1	$t_{c(SPC)M}$	Cycle time, SPICLK ⁽⁴⁾	50	$256t_{c(VCLK)}$	ns
2 ⁽⁵⁾	$t_{w(SPCH)M}$	Pulse duration, SPICLK high (clock polarity = 0)	$0.5t_{c(SPC)M} - 3 - t_r$	$0.5t_{c(SPC)M} + 5$	ns
	$t_{w(SPCL)M}$	Pulse duration, SPICLK low (clock polarity = 1)	$0.5t_{c(SPC)M} - 3 - t_f$	$0.5t_{c(SPC)M} + 5$	
3 ⁽⁵⁾	$t_{w(SPCL)M}$	Pulse duration, SPICLK low (clock polarity = 0)	$0.5t_{c(SPC)M} - 3 - t_r$	$0.5t_{c(SPC)M} + 5$	ns
	$t_{w(SPCH)M}$	Pulse duration, SPICLK high (clock polarity = 1)	$0.5t_{c(SPC)M} - 3 - t_f$	$0.5t_{c(SPC)M} + 5$	
4 ⁽⁵⁾	$t_{d(SIMO-SPCH)M}$	Delay time, SPICLK high after SPISIMO data valid (clock polarity = 0)	$0.5t_{c(SPC)M} - 10$		ns
	$t_{d(SIMO-SPCL)M}$	Delay time, SPICLK low after SPISIMO data valid (clock polarity = 1)	$0.5t_{c(SPC)M} - 10$		
5 ⁽⁵⁾	$t_{v(SPCH-SIMO)M}$	Valid time, SPISIMO data valid after SPICLK high (clock polarity = 0)	$0.5t_{c(SPC)M} - t_r(SPC) - 7$		ns
	$t_{v(SPCL-SIMO)M}$	Valid time, SPISIMO data valid after SPICLK low (clock polarity = 1)	$0.5t_{c(SPC)M} - t_f(SPC) - 7$		
6 ⁽⁵⁾	$t_{su(SOMI-SPCH)M}$	Setup time, SPISOMI before SPICLK high (clock polarity = 0)	$t_r(SPC) + 4$		ns
	$t_{su(SOMI-SPCL)M}$	Setup time, SPISOMI before SPICLK low (clock polarity = 1)	$t_f(SPC)$		
7 ⁽⁵⁾	$t_{v(SPCH-SOMI)M}$	Valid time, SPISOMI data valid after SPICLK high (clock polarity = 0)	10		ns
	$t_{v(SPCL-SOMI)M}$	Valid time, SPISOMI data valid after SPICLK low (clock polarity = 1)	10		
8 ⁽⁶⁾	$t_{C2TDELAY}$	Setup time CS active until SPICLK high, assumes that SPInENA is low at t_{SPIENA} (clock polarity = 0)	$(C2TDELAY + CSHOLD + 2) * t_{c(VCLK)} + 0.5 * t_{c(SPC)M} - t_f(SPICS) + t_r(SPC) - 9$	$(C2TDELAY + CSHOLD + 2) * t_{c(VCLK)} + 0.5 * t_{c(SPC)M} - t_f(SPICS) + t_r(SPC) + 5$	ns
		Setup time CS active until SPICLK low, assumes that SPInENA is low at t_{SPIENA} (clock polarity = 1)	$(C2TDELAY + CSHOLD + 2) * t_{c(VCLK)} + 0.5 * t_{c(SPC)M} - t_f(SPICS) + t_r(SPC) - 9$	$(C2TDELAY + CSHOLD + 2) * t_{c(VCLK)} + 0.5 * t_{c(SPC)M} - t_f(SPICS) + t_r(SPC) + 5$	ns
9 ⁽⁶⁾	$t_{T2CDELAY}$	Hold time SPICLK low until CS inactive (clock polarity = 0)	$T2CDELAY * t_{c(VCLK)} + t_{c(VCLK)} - t_r(SPC) + t_r(SPICS) - 5$	$T2CDELAY * t_{c(VCLK)} + t_{c(VCLK)} - t_r(SPC) + t_r(SPICS) + 10$	ns
		Hold time SPICLK high until CS inactive (clock polarity = 1)	$T2CDELAY * t_{c(VCLK)} + t_{c(VCLK)} - t_r(SPC) + t_r(SPICS) - 5$	$T2CDELAY * t_{c(VCLK)} + t_{c(VCLK)} - t_r(SPC) + t_r(SPICS) + 10$	ns
10	t_{SPIENA}	SPIENAn Sample Point	$C2TDELAY * t_{c(VCLK)} - t_f(SPICS) - 20$	$C2TDELAY * t_{c(VCLK)}$	ns
11	$t_{SPIENAW}$	SPIENAn Sample point from write to buffer		$(C2TDELAY + 2) * t_{c(VCLK)}$	ns

(1) The MASTER bit (SPIGCR1.0) is set and the CLOCK PHASE bit (SPIFMTx.16) is set.

(2) $t_{c(VCLK)}$ = interface clock cycle time = $1 / f(VCLK)$

(3) For rise and fall timings, see the "switching characteristics for output timings versus load capacitance" table.

(4) When the SPI is in Master mode, the following must be true:

For PS values from 1 to 255: $t_{c(SPC)M} \geq (PS + 1)t_{c(VCLK)} \geq 50$ ns, where PS is the prescale value set in the SPIFMTx.[15:8] register bits.

For PS values of 0: $t_{c(SPC)M} = 2t_{c(VCLK)} \geq 50$ ns. The external load on the SPICLK pin must be less than 60pF.

(5) The active edge of the SPICLK signal referenced is controlled by the CLOCK POLARITY bit (SPIFMTx.17).

(6) C2TDELAY and T2CDELAY are programmed in the SPIDELAY register

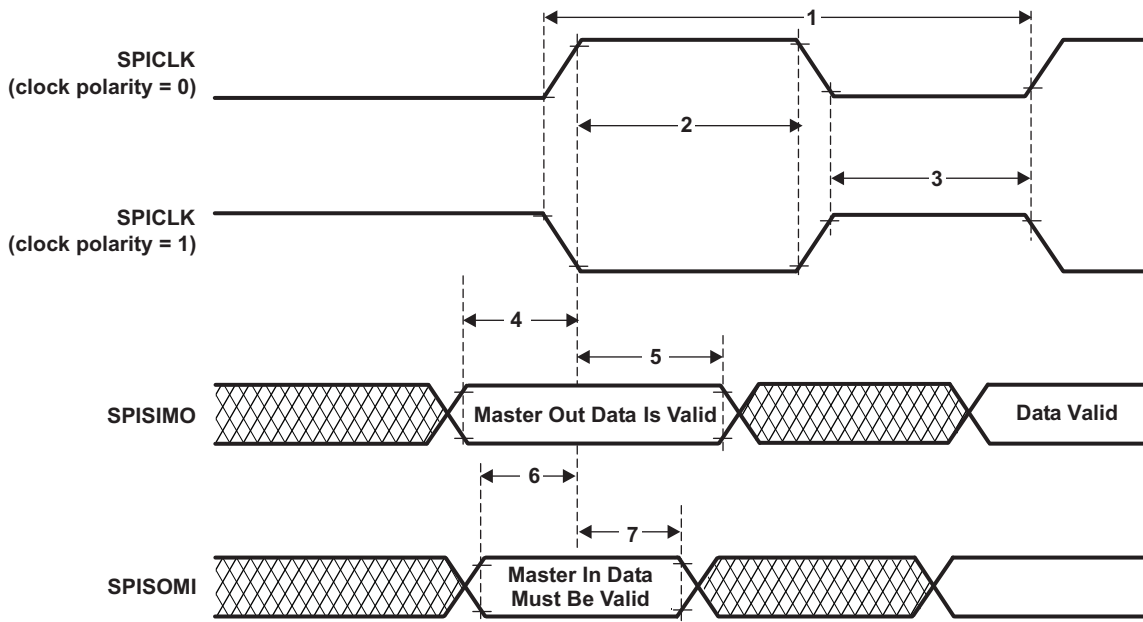

Figure 7-11. SPI Master Mode External Timing (CLOCK PHASE = 1)

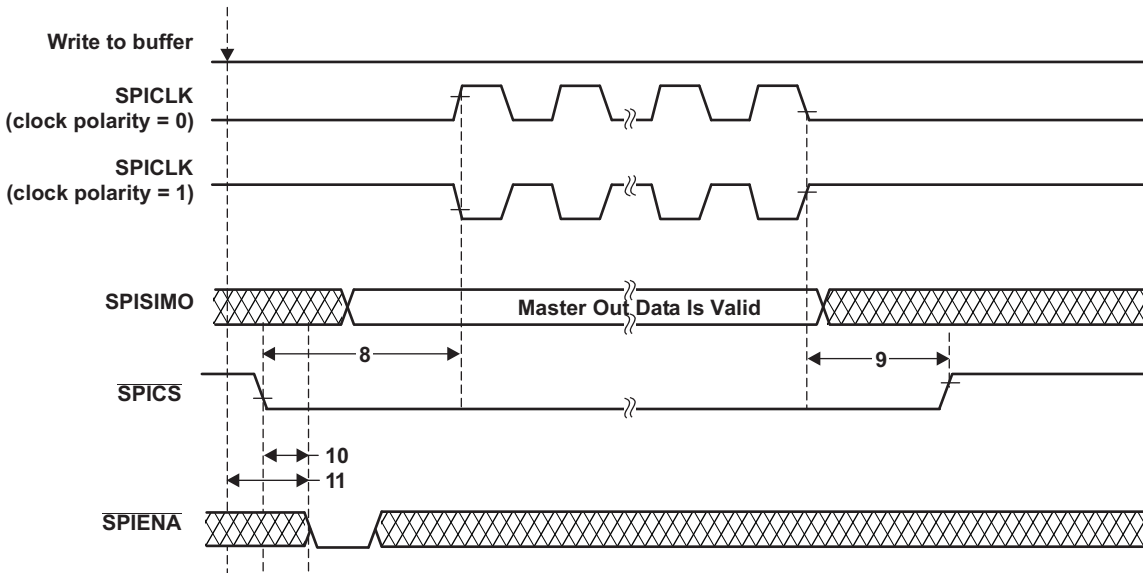

Figure 7-12. SPI Master Mode Chip Select timing (CLOCK PHASE = 1)

7.10 SPI Slave Mode Timing Parameters

7.10.1 SPI Slave Mode External Timing Parameters (CLOCK PHASE = 0, SPICLK = input, SPISIMO = input, and SPISOMI = output)

Table 7-15. SPI Slave Mode External Timing Parameters ⁽¹⁾⁽²⁾⁽³⁾

NO.			MIN	MAX	Unit
1	$t_{c(SPC)S}$	Cycle time, SPICLK ⁽⁴⁾	90		ns
2 ⁽⁵⁾	$t_{w(SPCH)S}$	Pulse duration, SPICLK high(clock polarity = 0)	30		ns
	$t_{w(SPCL)S}$	Pulse duration, SPICLK low(clock polarity = 1)	30		
3 ⁽⁵⁾	$t_{w(SPCL)S}$	Pulse duration, SPICLK low(clock polarity = 0)	30		ns
	$t_{w(SPCH)S}$	Pulse duration, SPICLK high(clock polarity = 1)	30		
4 ⁽⁵⁾	$t_{d(SPCH-SOMI)S}$	Delay time, SPISOMI valid after SPICLK high (clock polarity = 0)		$t_{f(SOMI)} + 15$	ns
	$t_{d(SPCL-SOMI)S}$	Delay time, SPISOMI valid after SPICLK low (clock polarity = 1)		$t_{f(SOMI)} + 15$	
5 ⁽⁵⁾	$t_{v(SPCH-SOMI)S}$	Valid time, SPISOMI data valid after SPICLK high (clock polarity = 0)	0		ns
	$t_{v(SPCL-SOMI)S}$	Valid time, SPISOMI data valid after SPICLK low (clock polarity = 1)	0		
6 ⁽⁵⁾	$t_{su(SIMO-SPCL)S}$	Setup time, SPISIMO before SPICLK low(clock polarity = 0)	4		ns
	$t_{su(SIMO-SPCH)S}$	Setup time, SPISIMO before SPICLK high(clock polarity = 1)	4		
7 ⁽⁵⁾	$t_{h(SPCL-SIMO)S}$	Hold time, SPISIMO data valid after SPICLK low (clock polarity = 0)	6		ns
	$t_{h(SPCH-SIMO)S}$	Hold time, SPISIMO data valid after SPICLK high (clock polarity = 1)	6		
8	$t_{d(SPCL-SENAH)S}$	Delay time, SPIENAn high after last SPICLK low (clock polarity = 0)	$1.5t_{c(VCLK)}$	$2.5t_{c(VCLK)} + t_{f(ENAn)} + 26$	ns
	$t_{d(SPCH-SENAH)S}$	Delay time, SPIENAn high after last SPICLK high (clock polarity = 1)	$1.5t_{c(VCLK)}$	$2.5t_{c(VCLK)} + t_{f(ENAn)} + 26$	
9	$t_{d(SCSL-SENAL)S}$	Delay time, SPIENAn low after SPICLK low (if new data has been written to the SPI buffer)	$t_{f(ENAn)}$	$t_{c(VCLK)} + t_{f(ENAn)} + 18$	ns

- (1) The MASTER bit (SPIGCR1.0) is set and the CLOCK PHASE bit (SPIFMTx.16) is set.
(2) $t_{c(VCLK)}$ = interface clock cycle time = $1 / f_{(VCLK)}$
(3) For rise and fall timings, see the "switching characteristics for output timings versus load capacitance" table.
(4) When the SPI is in Slave mode, the following must be true:
 $t_{c(SPC)S} > 2t_{c(VCLK)}$ and $t_{c(SPC)S} \geq 90$ ns.
 $t_{w(SPCH)S} > t_{c(VCLK)}$ and $t_{w(SPCL)S} > t_{c(VCLK)}$.
(5) The active edge of the SPICLK signal referenced is controlled by the CLOCK POLARITY bit (SPIFMTx.17).

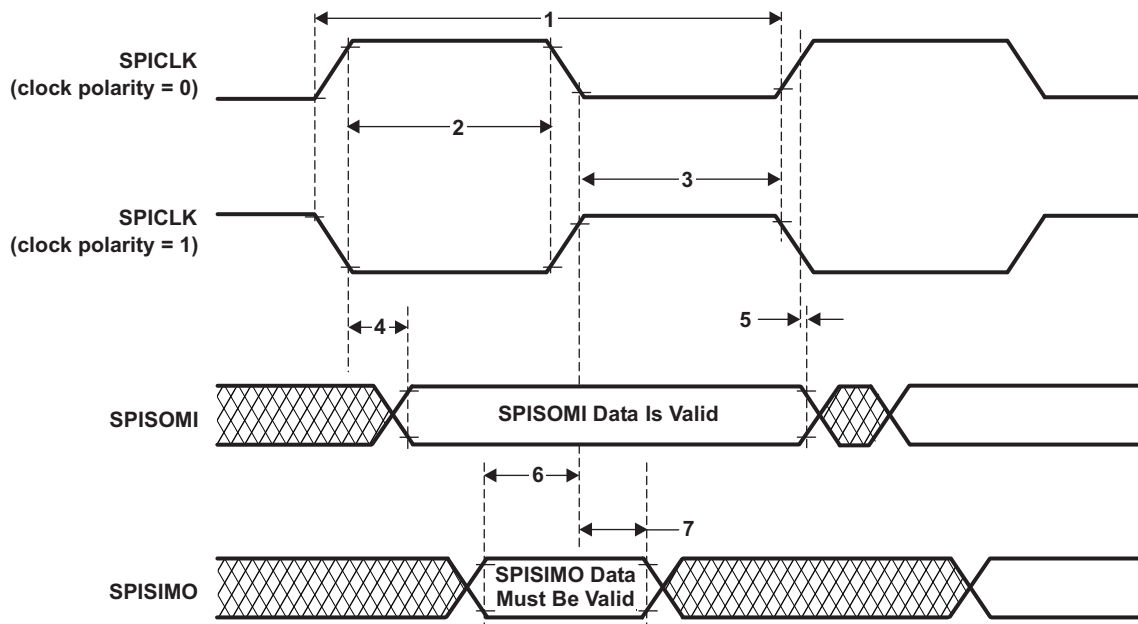

Figure 7-13. SPI Slave Mode External Timing (CLOCK PHASE = 0)

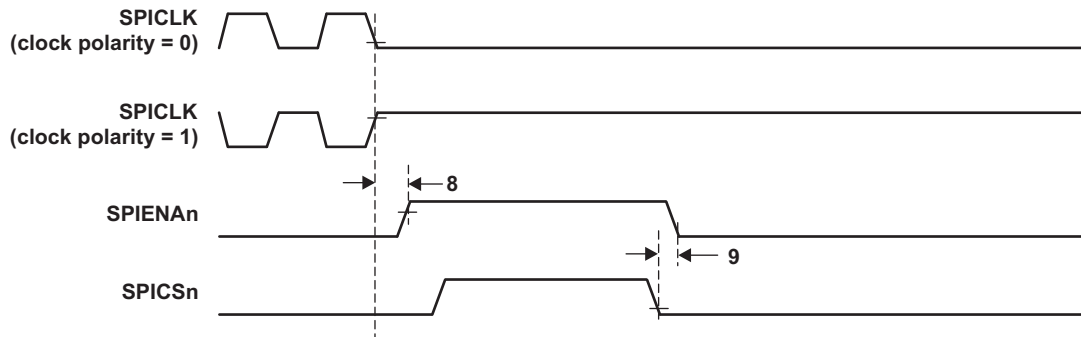

Figure 7-14. SPI Slave Mode Enable Timing (CLOCK PHASE = 0)

7.10.2 SPI Slave Mode External Timing Parameters (CLOCK PHASE = 1, SPICLK = input, SPISIMO = input, and SPISOMI = output)
Table 7-16. SPI Slave Mode External Timing Parameters⁽¹⁾⁽²⁾⁽³⁾

NO.			MIN	MAX	Unit
1	$t_{c(SPC)S}$	Cycle time, SPICLK ⁽⁴⁾	90		ns
2 ⁽⁵⁾	$t_{w(SPCH)S}$	Pulse duration, SPICLK high (clock polarity = 0)	30		ns
	$t_{w(SPCL)S}$	Pulse duration, SPICLK low (clock polarity = 1)	30		
3 ⁽⁵⁾	$t_{w(SPCL)S}$	Pulse duration, SPICLK low (clock polarity = 0)	30		ns
	$t_{w(SPCH)S}$	Pulse duration, SPICLK high (clock polarity = 1)	30		
4 ⁽⁵⁾	$t_{d(SOMI-SPCL)S}$	Delay time, SPISOMI data valid after SPICLK low (clock polarity = 0)		$t_{r(SOMI)}+15$	ns
	$t_{d(SOMI-SPCH)S}$	Delay time, SPISOMI data valid after SPICLK high (clock polarity = 1)		$t_{r(SOMI)}+15$	
5 ⁽⁵⁾	$t_{v(SPCL-SOMI)S}$	Valid time, SPISOMI data valid after SPICLK high (clock polarity = 0)	0		ns
	$t_{v(SPCH-SOMI)S}$	Valid time, SPISOMI data valid after SPICLK low (clock polarity = 1)	0		
6 ⁽⁵⁾	$t_{su(SIMO-SPCH)S}$	Setup time, SPISIMO before SPICLK high (clock polarity = 0)	4		ns
	$t_{su(SIMO-SPCL)S}$	Setup time, SPISIMO before SPICLK low (clock polarity = 1)	4		
7 ⁽⁵⁾	$t_{h(SPCH-SIMO)S}$	Hold time, SPISIMO data valid after SPICLK high (clock polarity = 0)	6		ns
	$t_{h(SPCL-SIMO)S}$	Hold time, SPISIMO data valid after SPICLK low (clock polarity = 1)	6		
8	$t_{d(SPCH-SENAH)S}$	Delay time, SPIENAn high after last SPICLK high (clock polarity = 0)	$1.5t_{c(VCLK)}$	$2.5t_{c(VCLK)}+t_{r(ENAn)}+ 26$	ns
	$t_{d(SPCL-SENAH)S}$	Delay time, SPIENAn high after last SPICLK low (clock polarity = 1)	$1.5t_{c(VCLK)}$	$2.5t_{c(VCLK)}+t_{r(ENAn)}+ 26$	
9	$t_{d(SCSL-SENAL)S}$	Delay time, SPIENAn low after SPICSn low (if new data has been written to the SPI buffer)	$t_{r(ENAn)}$	$t_{c(VCLK)} + t_{r(ENAn)}+ 18$	ns
10	$t_{d(SCSL-SOMI)S}$	Delay time, SOMI valid after SPICSn low (if new data has been written to the SPI buffer)	$t_{c(VCLK)}$	$2t_{c(VCLK)} + t_{r(SOMI)}+ 20$	ns

- (1) The MASTER bit (SPIGCR1.0) is set and the CLOCK PHASE bit (SPIFMTx.16) is set.
- (2) $t_{c(VCLK)}$ = interface clock cycle time = $1 / f_{(VCLK)}$
- (3) For rise and fall timings, see the "switching characteristics for output timings versus load capacitance" table.
- (4) When the SPI is in Slave mode, the following must be true:
 $t_{c(SPC)S} > 2t_{c(VCLK)}$ and $t_{c(SPC)S} \geq 90$ ns.
 $t_{w(SPCH)S} > t_{c(VCLK)}$ and $t_{w(SPCL)S} > t_{c(VCLK)}$.
- (5) The active edge of the SPICLK signal referenced is controlled by the CLOCK POLARITY bit (SPIFMTx.17).

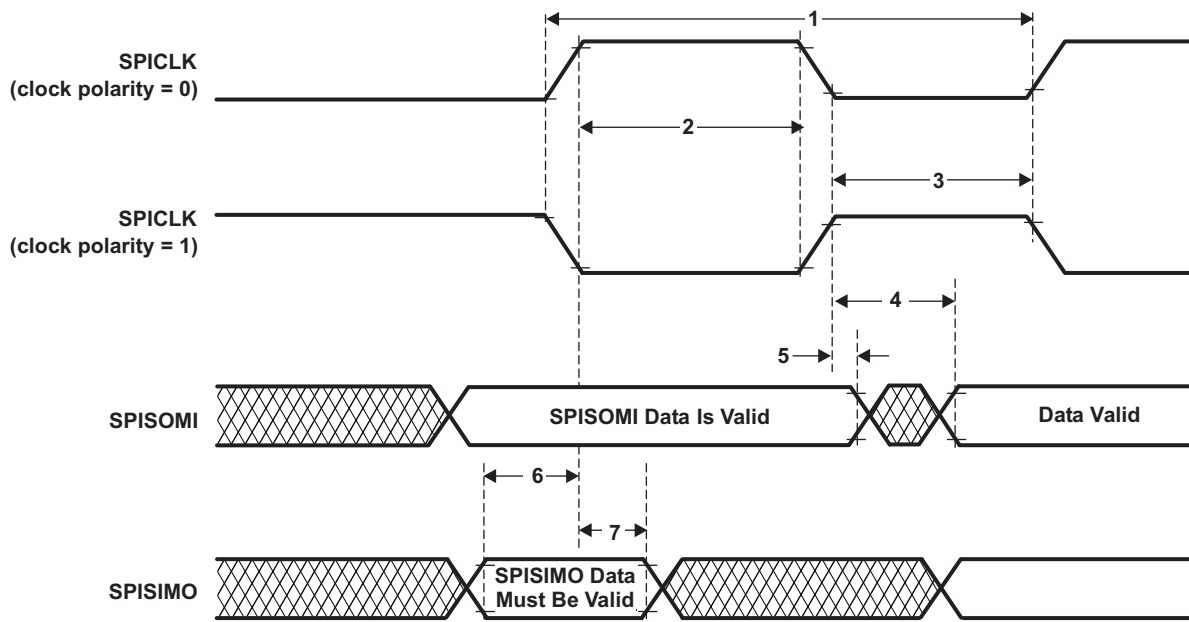

Figure 7-15. SPI Slave Mode External Timing (CLOCK PHASE = 1)

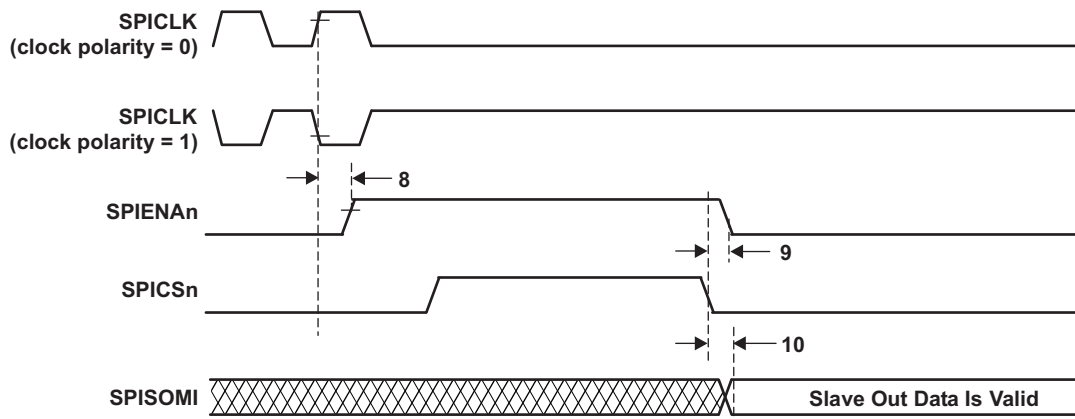

Figure 7-16. SPI Slave Mode Enable Timing (CLOCK PHASE = 1)

7.11 CAN Controller Mode Timings

7.11.1 Dynamic Characteristics For The CANnTX And CANnRX Pins

Table 7-17. Dynamic Characteristics For The CANnTX And CANnRX Pins⁽¹⁾

Parameter		MIN	MAX	Unit
$t_d(\text{CANnTX})$	Delay time, transmit shift register to CANnTX pin ⁽²⁾		15	ns
$t_d(\text{CANnRX})$	Delay time, CANnRX pin to receive shift register		5	ns

(1) These parameters are characterized from -40°C to 125°C only.

(2) These values do not include rise/fall times of the output buffer.

7.12 SCI/LIN Mode Timings

At 100MHz Peripheral Clock, 3.125 Mb/s is the Max SCI Baud Rate achievable.

7.13 FlexRay Controller Mode Timings

7.13.1 Jitter Timing

Table 7-18. Jitter Timing⁽¹⁾

Parameter		MIN	MAX	Unit
t_{Tx1bit}	clock jitter and signal symmetry	98	102	ns
$t_{Tx10bit}$	FlexRay BSS (byte start sequence) to BSS	999	1001	ns
$t_{Tx10bitAvg}$	average over 10000 samples	999.5	1000.5	ns
$t_{RxAsymDelay}$	delay difference between rise and fall from Rx pin to sample point in FlexRay core	-	2.5	ns

(1) Parameters characterized from -40°C to 125°C only.

7.14 EMIF Timings

Table 7-19. EMIF Read/Write Mode Switching Characteristics⁽¹⁾⁽²⁾

NO	Parameter	Description	MIN	MAX	Unit
Reads and Writes					
1	$t_3(\text{TURNAROUND})^{(3)}$	Turn around time	$(TA + 1) * E - t_{r(\text{CS})} - 2$	$(TA + 1) * E - t_{r(\text{CS})} + 3$	ns
Reads					
2	$t_c(\text{EMRCYCLE})$	EMIF read cycle time	$(RS + RST + RH + TA + 4) * E - t_{r(\text{CS})} - 3$	$(RS + RST + RH + TA + 4) * E - t_{r(\text{CS})} + 3$	ns
3	$t_{su}(\text{EMCSL-EMOEL})$	Output setup time, $\overline{\text{EMIFCS}}[3:0]$ low to $\overline{\text{EMIFOE}}$ low (SS=0)	$(RS + 1) * E - t_{r(\text{CS})} + t_{r(\text{OE})} - 5$	$(RS + 1) * E - t_{r(\text{CS})} + t_{r(\text{OE})} + 5$	ns
		Output setup time, $\overline{\text{EMIFCS}}[3:0]$ low to $\overline{\text{EMIFOE}}$ low (SS=1)	$- t_{r(\text{CS})} + t_{r(\text{OE})} - 5$	$- t_{r(\text{CS})} + t_{r(\text{OE})} + 5$	ns
4	$t_h(\text{EMOEEH-EMCSH})$	Output hold time, $\overline{\text{EMIFOE}}$ high to $\overline{\text{EMIFCS}}[3:0]$ high (SS=0)	$(RH + 1) * E - t_{r(\text{OE})} + t_{r(\text{CS})} - 4$	$(RH + 1) * E - t_{r(\text{OE})} + t_{r(\text{CS})} + 6$	ns
		Output hold time, $\overline{\text{EMIFOE}}$ high to $\overline{\text{EMIFCS}}[3:0]$ high (SS=1)	$- t_{r(\text{OE})} + t_{r(\text{CS})} - 4$	$- t_{r(\text{OE})} + t_{r(\text{CS})} + 6$	ns
5	$t_{su}(\text{EMBAV-EMOEL})$	Output setup time, EMIFBADD[1:0] valid to $\overline{\text{EMIFOE}}$ low	$(RS + 1) * E - t_{r(\text{AD})} + t_{r(\text{OE})} - 5$	$(RS + 1) * E - t_{r(\text{AD})} + t_{r(\text{OE})} + 5$	ns
6	$t_h(\text{EMOEEH-EMBAIV})$	Output hold time, $\overline{\text{EMIFOE}}$ high to EMIFBADD[1:0] invalid	$(RH + 1) * E - t_{r(\text{OE})} - 5$	$(RH + 1) * E - t_{r(\text{OE})} + 5$	ns
7	$t_{su}(\text{EMAV-EMOEL})$	Output setup time, EMIFADD[21:0] valid to $\overline{\text{EMIFOE}}$ low	$(RS + 1) * E - t_{r(\text{AD})} + t_{r(\text{OE})} - 6$	$(RS + 1) * E - t_{r(\text{AD})} + t_{r(\text{OE})} + 6$	ns
8	$t_h(\text{EMOEEH-EMAIV})$	Output hold time, $\overline{\text{EMIFOE}}$ high to EMIFADD[21:0] invalid	$(RH + 1) * E - t_{r(\text{OE})} - 5$	$(RH + 1) * E - t_{r(\text{OE})} + 6$	ns
9	$t_w(\text{EMOEL})^{(3)}$	$\overline{\text{EMIFOE}}$ active low width	$(RST + 1) * E - t_{r(\text{OE})} - 1$	$(RST + 1) * E - t_{r(\text{OE})} + 0$	ns
10	$t_{su}(\text{EMDV-EMOEH})$	Setup time, EMIFD[15:0] valid before $\overline{\text{EMIFOE}}$ high	$t_{r(\text{OE})} + 9$		ns
11	$t_h(\text{EMOEEH-EMDV})$	Hold time, EMIFD[15:0] valid after $\overline{\text{EMIFOE}}$ high	$- t_{r(\text{OE})} - 3$		
Writes					
12	$t_c(\text{EMWCYCLE})$	EMIF write cycle time	$(WS + WST + WH + TA + 4) * E - t_{r(\text{CS})} - 3$	$(WS + WST + WH + TA + 4) * E - t_{r(\text{CS})} + 2$	ns
13	$t_{su}(\text{EMCSL-EMWEL})$	Output setup time, $\overline{\text{EMIFCS}}[3:0]$ low to $\overline{\text{EMIFWE}}$ low (SS=0)	$(WS + 1) * E - t_{r(\text{CS})} + t_{r(\text{WE})} - 5$	$(WS + 1) * E - t_{r(\text{CS})} + t_{r(\text{WE})} + 5$	ns
		Output setup time, $\overline{\text{EMIFCS}}[3:0]$ low to $\overline{\text{EMIFWE}}$ low (SS=1)	$- t_{r(\text{CS})} + t_{r(\text{WE})} - 5$	$- t_{r(\text{CS})} + t_{r(\text{WE})} + 5$	ns
14	$t_h(\text{EMWEH-EMCSH})$	Output hold time, $\overline{\text{EMIFWE}}$ high to $\overline{\text{EMIFCS}}[3:0]$ high (SS=0)	$(WH + 1) * E - t_{r(\text{WE})} + t_{r(\text{CS})} - 4$	$(WH + 1) * E - t_{r(\text{WE})} + t_{r(\text{CS})} + 5$	ns
		Output hold time, $\overline{\text{EMIFWE}}$ high to $\overline{\text{EMIFCS}}[3:0]$ high (SS=1)	$- t_{r(\text{WE})} + t_{r(\text{CS})} - 4$	$- t_{r(\text{WE})} + t_{r(\text{CS})} + 5$	ns
15	$t_{su}(\text{EMBAV-EMWEL})$	Output setup time, EMIFBADD[1:0] valid to $\overline{\text{EMIFWE}}$ low	$(WS + 1) * E - t_{r(\text{AD})} + t_{r(\text{WE})} - 5$	$(WS + 1) * E - t_{r(\text{AD})} + t_{r(\text{WE})} + 5$	ns
16	$t_h(\text{EMWEH-EMBAIV})$	Output hold time, $\overline{\text{EMIFWE}}$ high to EMIBADD[1:0] invalid	$(WH + 1) * E - t_{r(\text{WE})} - 5$	$(WH + 1) * E - t_{r(\text{WE})} + 5$	ns
17	$t_{su}(\text{EMAV-EMWEL})$	Output setup time, EMIFADD[21:0] valid to $\overline{\text{EMIFWE}}$ low	$(WS + 1) * E - t_{r(\text{AD})} + t_{r(\text{WE})} - 6$	$(WS + 1) * E - t_{r(\text{AD})} + t_{r(\text{WE})} + 6$	ns

(1) RS = Read setup, RST = Read Strobe, RH = Read Hold, WS = Write Setup, WST = Write Strobe, WH = Write Hold, TA = Turn Around, SS = Strobe Select Mode

(2) E = VCLK period in ns.

(3) Parameters characterized from -40°C to 125°C only.

Table 7-19. EMIF Read/Write Mode Switching Characteristics⁽¹⁾⁽²⁾ (continued)

NO	Parameter	Description	MIN	MAX	Unit
18	$t_{h(EMWEH-EMAIV)}$	Output hold time, \overline{EMIFWE} high to EMIFADD[21:0] invalid	$(WH + 1) * E - t_{r(WE)} - 5$	$(WH + 1) * E - t_{r(WE)} + 6$	ns
19	$t_{w(EMWEL)}^{(1)}$	\overline{EMIFWE} active low width	$(WST + 1) * E - t_{r(WE)} - 1$	$(WST + 1) * E - t_{r(WE)} + 1$	
20	$t_{su(EMDV-ENWEL)}$	Output setup time, EMIFD[15:0] valid to \overline{EMIFWE} low	$(WS + 1) * E - t_{rf(DA)} + t_{r(WE)} - 6$	$(WS + 1) * E - t_{rf(DA)} + t_{r(WE)} + 5$	ns
21	$t_{h(EMWEH-EMDIV)}$	Output hold time, EMIFD[15:0] valid after \overline{EMIFWE} high	$(WH + 1) * E - t_{r(WE)} - 5$	$(WH + 1) * E - t_{r(WE)} + 5$	ns

(1) Parameters characterized from -40°C to 125°C only.

7.14.1 Read Timing (Asynchronous RAM)

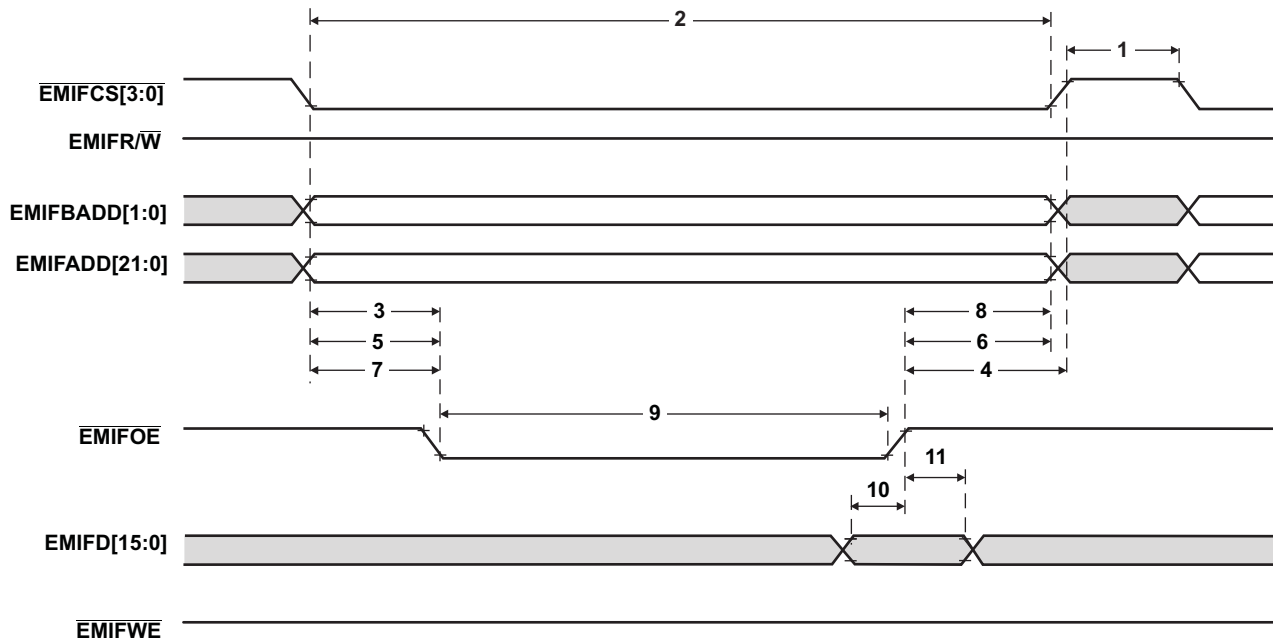

Figure 7-17. Asynchronous Memory Read Timing for EMIF

7.14.2 Write Timing (Asynchronous RAM)

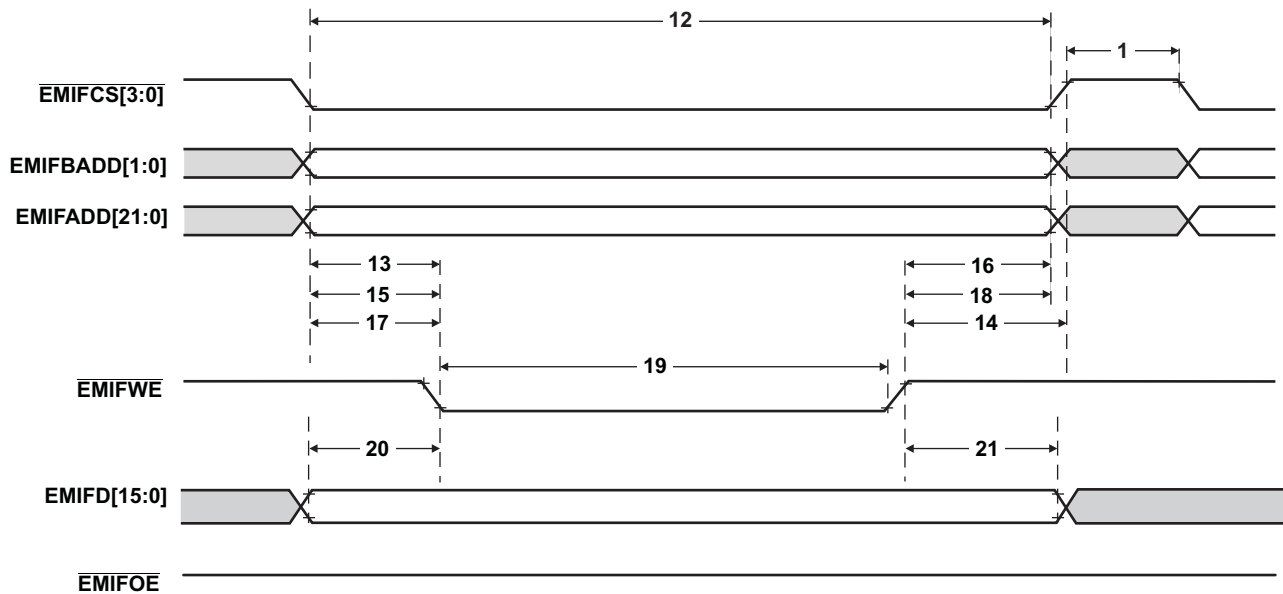

Figure 7-18. Asynchronous Memory Write Timing for EMIF

7.15 ETM Timings

7.15.1 ETMTRACECLK Timing

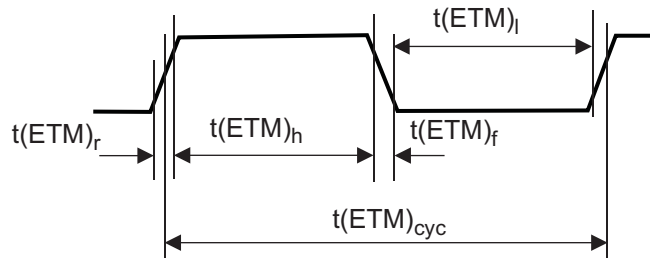

Figure 7-19. ETMTRACECLK Timing

Table 7-20. ETMTRACECLK Timing

Parameter	Minimum	Maximum	Description
f(ETM) _{cyc}		40MHz	Clock frequency
t(ETM) _{cyc}	25ns		Clock period
t(ETM) _l	2ns		Low pulse width
t(ETM) _h	2ns		High pulse width
t(ETM) _r	3ns		Clock and data rise time
t(ETM) _f	3ns		Clock and data fall time

7.15.2 ETMDATA Timing

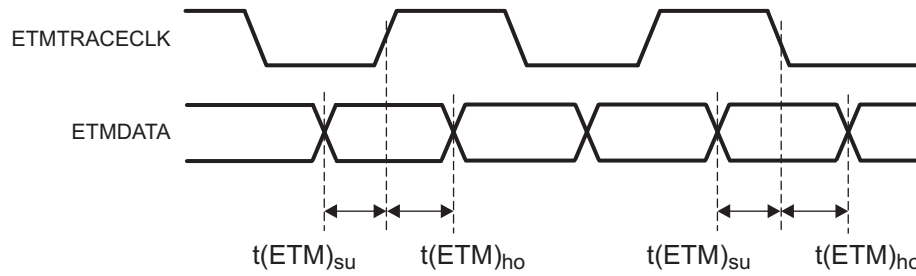

Figure 7-20. ETMDATA Timing

Table 7-21. ETMDATA Timing

Parameter	Typical	Description
$t(\text{ETM})_{\text{su}}$	2.5ns	Data setup time
$t(\text{ETM})_{\text{ho}}$	1.5ns	Data hold time

Note: The timings in this table are measured with a 50pF and 50μA load. And they are measured at the 50% point, not 20% or 80% point. 'Typical' means 25°C and nominal voltage.

7.16 RTP Timings

7.16.1 RTPCLK Timing

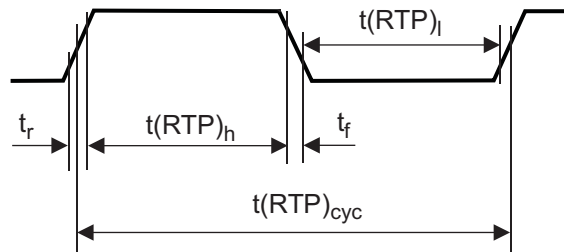

Figure 7-21. RTPCLK Timing

Table 7-22. RTPCLK Timing

Parameter	Minimum	Description
$t(RTP)_{cyc}$	10 ns	Clock period (depending on HCLK divide ratio)
$t(RTP)_h$	$(t(RTP)_{cyc}/2) - ((t_r+t_f)/2) - 1.5$	High pulse width (depending on HCLK divide ratio and load on pin)
$t(RTP)_l$	$(t(RTP)_{cyc}/2) - ((t_r+t_f)/2) - 1.5$	Low pulse width (depending on HCLK divide ratio and load on pin)

7.16.2 RTPDATA Timing

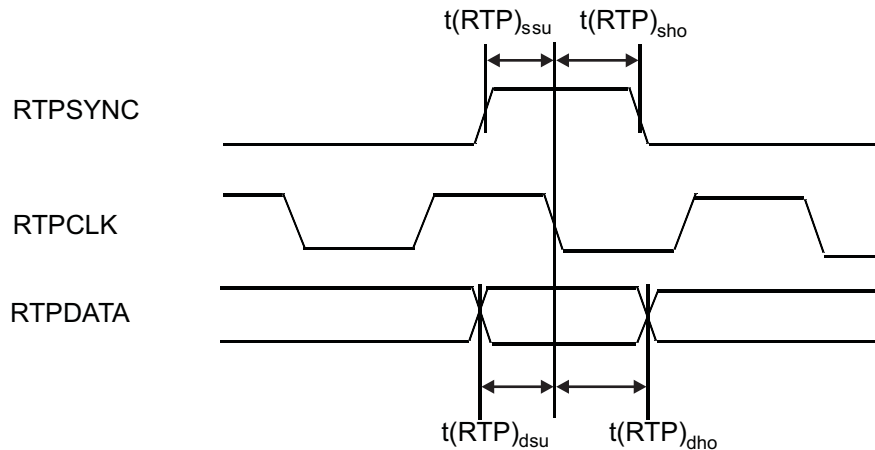

Figure 7-22. RTPDATA Timing

Table 7-23. RTPDATA Timing

Parameter	Minimum	Description
$t(RTP)_{dsu}$	$0.5 t(RTP)_{cyc} - 3ns$	Data setup time
$t(RTP)_{dho}$	$0.5 t(RTP)_{cyc} - 2ns$	Data hold time
$t(RTP)_{ssu}$	$0.5 t(RTP)_{cyc} - 3ns$	SYNC setup time
$t(RTP)_{sho}$	$0.5 t(RTP)_{cyc} - 2ns$	SYNC hold time

Note: The timings in this table are measured with a 50pF and 50μA load. And they are measured at the 50% point, not 20% or 80% point.

7.16.3 RTPENABLE Timing

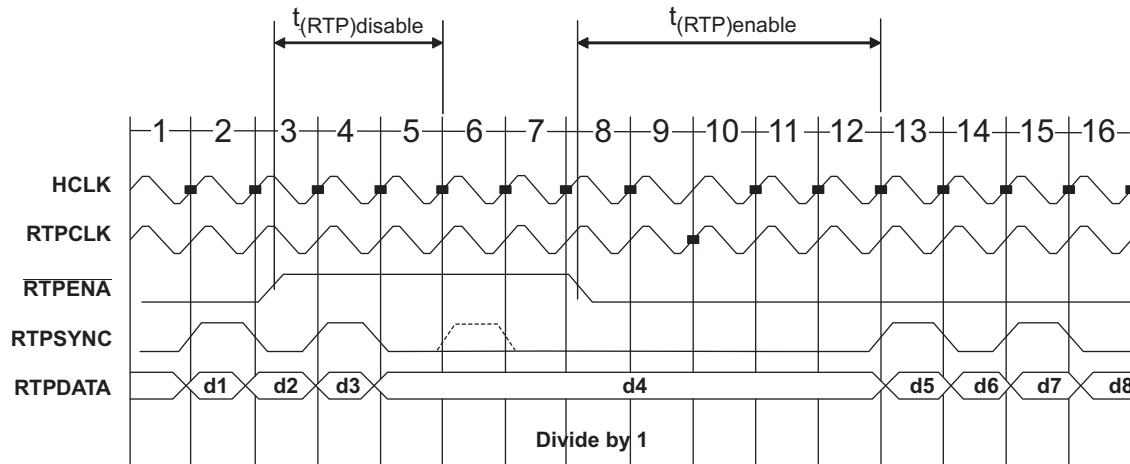

Figure 7-23. RTPENABLE Timing

Table 7-24. RTPENABLE Timing

Parameter	Minimum	Maximum	Description
$t_{(RTP)disable}$	$1.5t_{c(HCLK)} + t_{r(RTPSYNC)} + 12ns$		Time that \overline{RTPENA} must go high before the next scheduled RTPSYNC in order to suspend transmission for the packet following the scheduled RTPSYNC.
$t_{(RTP)enable}$	$4.5t_{c(HCLK)} + t_{r(RTPSYNC)}$	$5.5t_{c(HCLK)} + t_{r(RTPSYNC)} + 12ns$	Time after \overline{RTPENA} goes low before a packet that has been halted, resumes.

7.17 DMM Timings

7.17.1 DMMCLK Timing

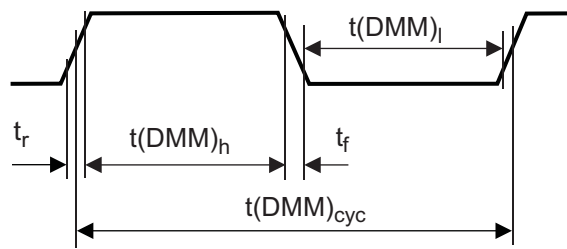

Figure 7-24. DMMCLK Timing

Table 7-25. DMMCLK Timing

Parameter	Minimum	Description
$t(\text{DMM})_{\text{cyc}}$	$t_{\text{c(HCLK)}} * 2$	Clock period
$t(\text{DMM})_{\text{h}}$	$t(\text{DMM})_{\text{cyc}}/2 - (t_{\text{r}} + t_{\text{f}})/2$	High pulse width
$t(\text{DMM})_{\text{l}}$	$t(\text{DMM})_{\text{cyc}}/2 - (t_{\text{r}} + t_{\text{f}})/2$	Low pulse width

7.17.2 DMMDATA Timing

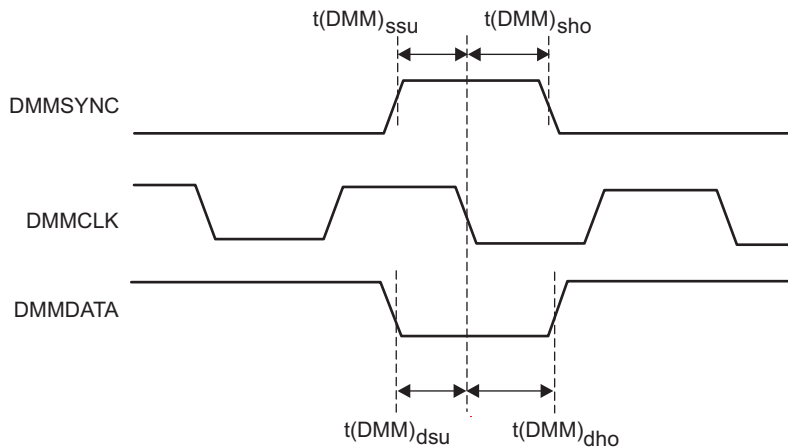

Figure 7-25. DMMDATA Timing

Table 7-26. DMMDATA Timing

Parameter	Minimum	Description
$t(\text{DMM})_{\text{ssu}}$	2ns	SYNC active to clk falling edge setup time
$t(\text{DMM})_{\text{sho}}$	3ns	clk falling edge to SYNC deactive hold time
$t(\text{DMM})_{\text{dsu}}$	2ns	DATA to clk falling edge setup time
$t(\text{DMM})_{\text{dho}}$	3ns	clk falling edge to DATA hold time

7.17.3 DMMENA Timing

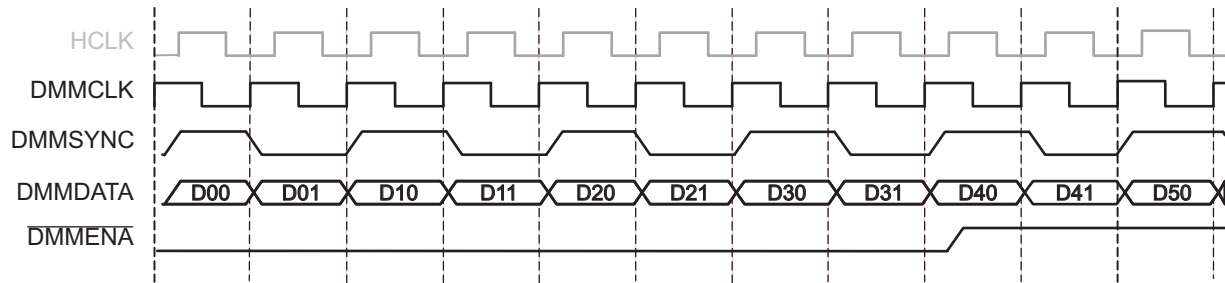

Figure 7-26. DMMENA Timing

The above figure shows a case with 1 DMM packet per 2 DMMCLK cycles (Mode = Direct Data Mode, data width = 8, portwidth = 4) where none of the packets received by the DMM are sent out, leading to filling up of the internal buffers. The DMMENA signal is shown asserted, after the first two packets have been received and synchronized to the HCLK domain. Here, the DMM has the capacity to accept packets D4, D5, D6, D7. Packet D8 would result in an overflow. Once DMMENA is asserted, the DMM expects to stop receiving packets after 4 HCLK cycles; once DMMENA is de-asserted, the DMM can handle packets immediately (after 0 HCLK cycles).

7.18 MibADC

7.18.1 MibADC

The multibuffered A-to-D converter (MibADC) has a separate power bus for its analog circuitry that enhances the A-to-D performance by preventing digital switching noise on the logic circuitry which could be present on VSS and VCC from coupling into the A-to-D analog stage. All A-to-D specifications are given with respect to ADREFLO unless otherwise noted.

Table 7-27. MibADC

Resolution	12 bits (4096 values)
Monotonic	Assured
Output conversion ϕ code	00h to FFFh [00 for $V_{AI} \leq AD_{REFLO}$; FFF for $V_{AI} \geq AD_{REFHI}$]

7.18.2 MibADC Recommended Operating Conditions

Table 7-28. MibADC Recommended Operating Conditions⁽¹⁾

		MIN	MAX	UNIT
AD _{REFHI}	A-to-D high-voltage reference source	3	3.6	V
AD _{REFLO}	A-to-D low-voltage reference source	0	0.3	V
V _{AI}	Analog input voltage	AD _{REFLO}	AD _{REFHI}	V
I _{AIC}	Analog input clamp current ⁽²⁾ ($V_{AI} < V_{SSAD} - 0.3$ or $V_{AI} > V_{CCAD} + 0.3$)	-2	2	mA

- (1) For V_{CCAD} and V_{SSAD} recommended operating conditions, see the "device recommended operating conditions" table.
 (2) Input currents into any ADC input channel outside the specified limits could affect conversion results of other channels.

7.18.3 Operating Characteristics Over Full Ranges Of Recommended Operating Conditions

Table 7-29. Operating Characteristics Over Full Ranges Of Recommended Operating Conditions⁽¹⁾

Parameter		Description/Conditions	Min	TYP	Max	Unit
$R_{mux}^{(2)}$	Analog input mux on-resistance				250	Ω
$R_{samp}^{(2)}$	ADC sample switch on-resistance			150	250	Ω
C_{mux}	Input mux capacitance				16	pF
C_{samp}	ADC sample capacitance		11	12	13	pF
I_{AIL}	Analog input leakage current	Input leakage per ADC input pin	-200		200	nA
$I_{ADREFHI}^{(2)}$	ADREFHI input current	$AD_{REFHI} = 3.6\text{ V}$, $AD_{REFLO} = V_{SSAD}$			5	mA
CR	Conversion range over which specified accuracy is maintained	$AD_{REFHI} - AD_{REFLO}$	3		3.6	V
E_{DNL}	Differential nonlinearity error	Difference between the actual step width and the ideal value.			± 3.8	LSB
E_{INL}	Integral nonlinearity error	Maximum deviation from the best straight line through the MibADC. MibADC transfer characteristics, excluding the quantization error.			± 3.7	LSB
E_{TOT}	Total error/Absolute accuracy	Maximum value of the difference between an analog value and the ideal midstep value.	Executing periodic internal calibration		$\pm 8^{(3)}$	LSB
			No calibration		± 15	LSB

(1) $1\text{ LSB} = (AD_{REFHI} - AD_{REFLO}) / 2^{12}$ for the MibADC

(2) This parameter is characterized from -40°C to 125°C only.

(3) An periodic internal offset calibration is required to achieve the absolute accuracy. Please refer to the *Analog To Digital Converter (ADC) Module* chapter of the *TMS570LS Series Microcontroller Technical Reference Manual (SPNU489)* and *Interfacing the Embedded 12-bit ADC (SPNA129)* for more information.

7.18.4 MibADC Input Model

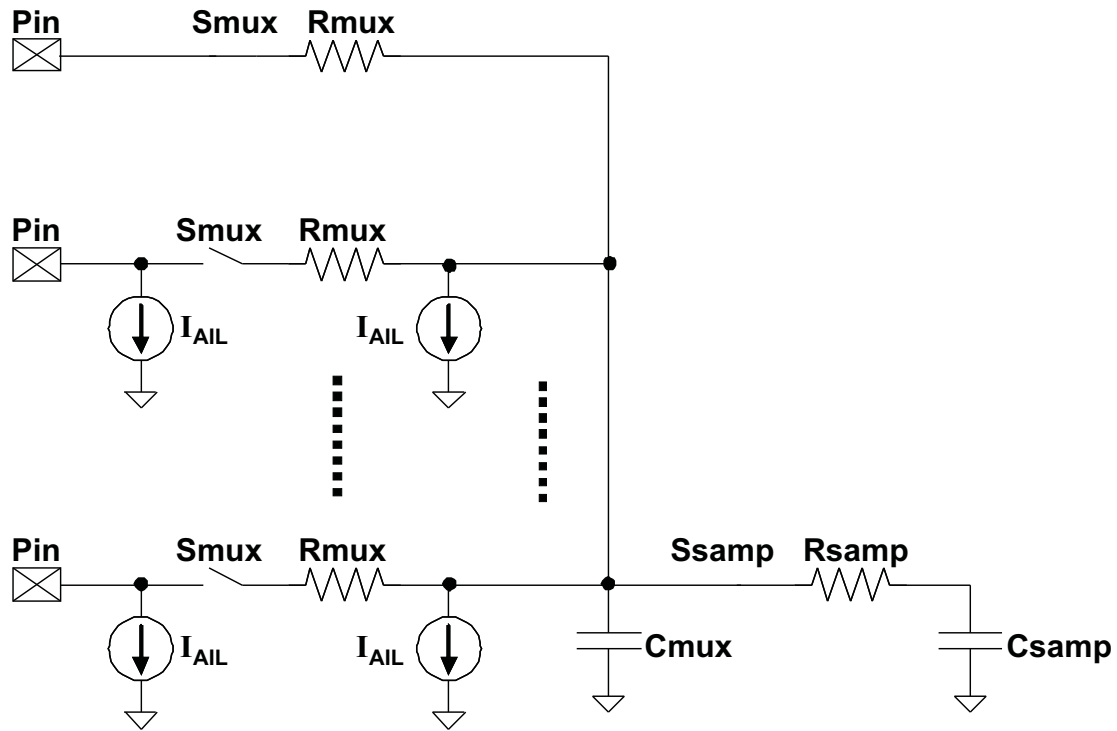

Figure 7-27. MibADC Input Equivalent Circuit

7.18.5 MibADC Timings

Table 7-30. MibADC Timings⁽¹⁾

		Min	NOM	MAX	Unit
$t_{c(ADCLK)}$	Cycle time, MibADC clock	33			ns
$t_{d(SH)}$	Delay time, sample and hold time	200			ns
$t_{d(C)}$	Delay time, conversion time	400			ns
$t_{d(SHC)}^{(2)}$	Delay time, total sample/hold and conversion time	600			ns

(1) These parameters are characterized from -40°C to 125°C only.

(2) This is the minimum sample/hold and conversion time that can be achieved. These parameters are dependent on many factors, e.g the prescale settings.

7.18.6 MibADC Nonlinearity Error

The differential nonlinearity error shown in the figure below (sometimes referred to as differential linearity) is the difference between an actual step width and the ideal value of 1 LSB.

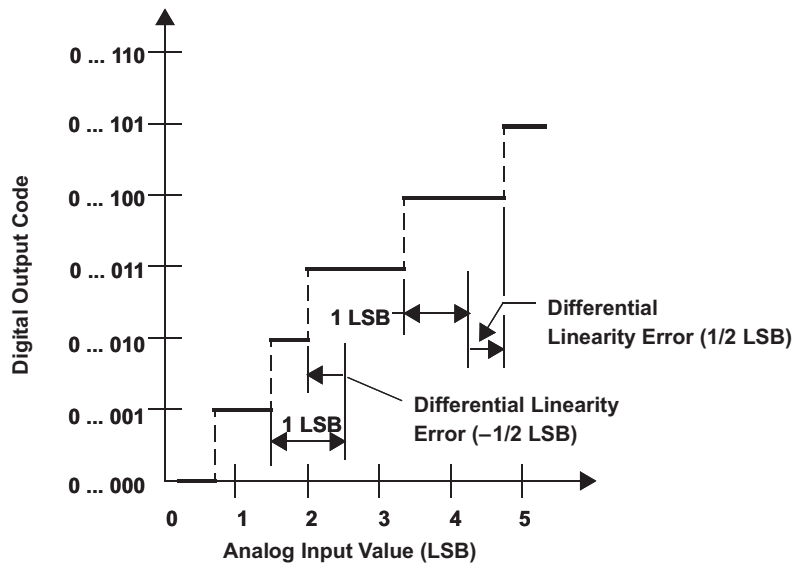

Figure 7-28. Differential Nonlinearity (DNL) Error

The integral nonlinearity error shown in the figure below (sometimes referred to as linearity error) is the deviation of the values on the actual transfer function from a straight line.

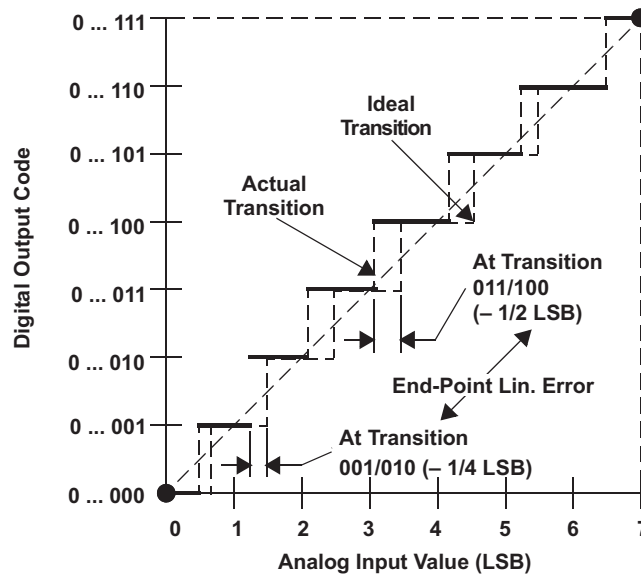

Figure 7-29. Integral Nonlinearity (INL) Error

7.18.7 MibADC Total Error

The absolute accuracy or total error of an MibADC as shown in the figure below is the maximum value of the difference between an analog value and the ideal midstep value.

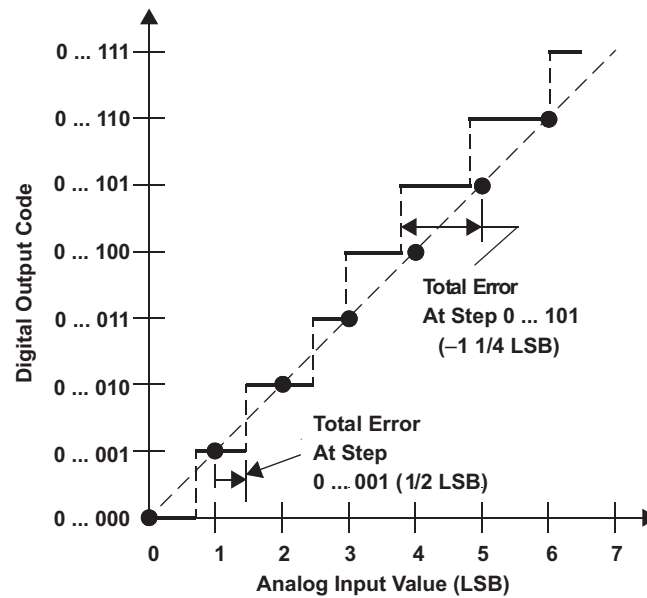

Figure 7-30. Absolute Accuracy (Total) Error

8 Mechanical Packaging and Orderable Information

8.1 Packaging Information

The following packaging information and addendum reflect the most current data available for the designated device(s). The data is subject to change without notice and without revision of this document.

PACKAGING INFORMATION

Orderable Device	Status (1)	Package Type	Package Drawing	Pins	Package Qty	Eco Plan (2)	Lead finish/ Ball material (6)	MSL Peak Temp (3)	Op Temp (°C)	Device Marking (4/5)	Samples
S5LS20206ASGWTMEP	ACTIVE	NFBGA	GWT	337	90	Non-RoHS & Green	SNPB	Level-3-220C-168 HR	-55 to 125	TMS570 S20206ASGWTMEP	Samples
S5LS20206ASPGEMEP	ACTIVE	LQFP	PGE	144	60	RoHS & Green	NIPDAU	Level-3-260C-168 HR	-55 to 125	S20206ASPGEMEP TMS570LS	Samples
S5LS20216ASGWTMEP	ACTIVE	NFBGA	GWT	337	90	Non-RoHS & Green	SNPB	Level-3-220C-168 HR	-55 to 125	TMS570 S20216ASGWTMEP	Samples
S5LS20216ASPGEMEP	ACTIVE	LQFP	PGE	144	60	RoHS & Green	NIPDAU	Level-3-260C-168 HR	-55 to 125	S20216ASPGEMEP TMS570LS	Samples
V62/12622-01XE	ACTIVE	LQFP	PGE	144	60	RoHS & Green	NIPDAU	Level-3-260C-168 HR	-55 to 125	S20206ASPGEMEP TMS570LS	Samples
V62/12622-01YE	ACTIVE	NFBGA	GWT	337	90	Non-RoHS & Green	SNPB	Level-3-220C-168 HR	-55 to 125	TMS570 S20206ASGWTMEP	Samples
V62/12622-02XE	ACTIVE	LQFP	PGE	144	60	RoHS & Green	NIPDAU	Level-3-260C-168 HR	-55 to 125	S20216ASPGEMEP TMS570LS	Samples
V62/12622-02YE	ACTIVE	NFBGA	GWT	337	90	Non-RoHS & Green	SNPB	Level-3-220C-168 HR	-55 to 125	TMS570 S20216ASGWTMEP	Samples

(1) The marketing status values are defined as follows:

ACTIVE: Product device recommended for new designs.

LIFEBUY: TI has announced that the device will be discontinued, and a lifetime-buy period is in effect.

NRND: Not recommended for new designs. Device is in production to support existing customers, but TI does not recommend using this part in a new design.

PREVIEW: Device has been announced but is not in production. Samples may or may not be available.

OBSELETE: TI has discontinued the production of the device.

(2) **RoHS:** TI defines "RoHS" to mean semiconductor products that are compliant with the current EU RoHS requirements for all 10 RoHS substances, including the requirement that RoHS substance do not exceed 0.1% by weight in homogeneous materials. Where designed to be soldered at high temperatures, "RoHS" products are suitable for use in specified lead-free processes. TI may reference these types of products as "Pb-Free".

RoHS Exempt: TI defines "RoHS Exempt" to mean products that contain lead but are compliant with EU RoHS pursuant to a specific EU RoHS exemption.

Green: TI defines "Green" to mean the content of Chlorine (Cl) and Bromine (Br) based flame retardants meet JS709B low halogen requirements of <=1000ppm threshold. Antimony trioxide based flame retardants must also meet the <=1000ppm threshold requirement.

(3) MSL, Peak Temp. - The Moisture Sensitivity Level rating according to the JEDEC industry standard classifications, and peak solder temperature.

(4) There may be additional marking, which relates to the logo, the lot trace code information, or the environmental category on the device.

⁽⁵⁾ Multiple Device Markings will be inside parentheses. Only one Device Marking contained in parentheses and separated by a "~" will appear on a device. If a line is indented then it is a continuation of the previous line and the two combined represent the entire Device Marking for that device.

⁽⁶⁾ Lead finish/Ball material - Orderable Devices may have multiple material finish options. Finish options are separated by a vertical ruled line. Lead finish/Ball material values may wrap to two lines if the finish value exceeds the maximum column width.

Important Information and Disclaimer:The information provided on this page represents TI's knowledge and belief as of the date that it is provided. TI bases its knowledge and belief on information provided by third parties, and makes no representation or warranty as to the accuracy of such information. Efforts are underway to better integrate information from third parties. TI has taken and continues to take reasonable steps to provide representative and accurate information but may not have conducted destructive testing or chemical analysis on incoming materials and chemicals. TI and TI suppliers consider certain information to be proprietary, and thus CAS numbers and other limited information may not be available for release.

In no event shall TI's liability arising out of such information exceed the total purchase price of the TI part(s) at issue in this document sold by TI to Customer on an annual basis.

OTHER QUALIFIED VERSIONS OF TMS570LS20206-EP, TMS570LS20216-EP :

- Catalog : [TMS570LS20206](#), [TMS570LS20216](#)

NOTE: Qualified Version Definitions:

- Catalog - TI's standard catalog product

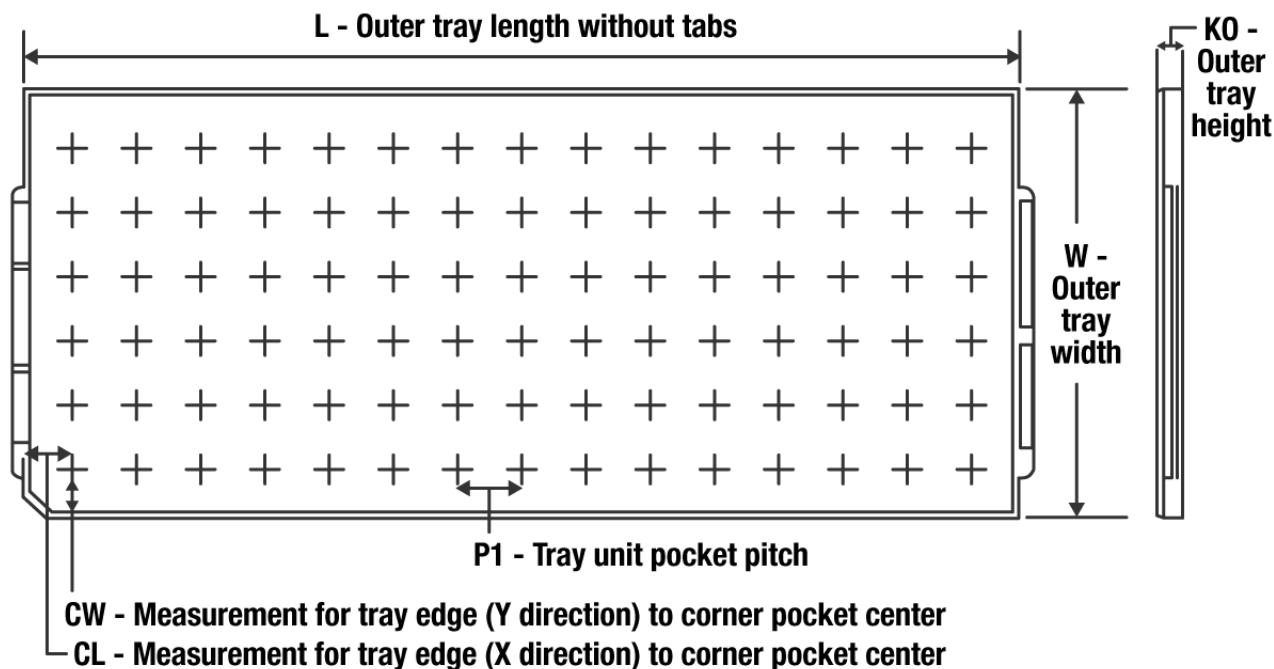
TRAY

Chamfer on Tray corner indicates Pin 1 orientation of packed units.

*All dimensions are nominal

Device	Package Name	Package Type	Pins	SPQ	Unit array matrix	Max temperature (°C)	L (mm)	W (mm)	K0 (µm)	P1 (mm)	CL (mm)	CW (mm)
S5LS20206ASPGEMEP	PGE	LQFP	144	60	5X12	150	315	135.9	7620	25.4	17.8	17.55
S5LS20216ASGWTMEP	GWT	NFBGA	337	90	6 X 15	150	315	135.9	7620	20	17.5	15.45
S5LS20216ASPGEMEP	PGE	LQFP	144	60	5X12	150	315	135.9	7620	25.4	17.8	17.55
V62/12622-01XE	PGE	LQFP	144	60	5X12	150	315	135.9	7620	25.4	17.8	17.55
V62/12622-02XE	PGE	LQFP	144	60	5X12	150	315	135.9	7620	25.4	17.8	17.55
V62/12622-02YE	GWT	NFBGA	337	90	6 X 15	150	315	135.9	7620	20	17.5	15.45

GWT0337A

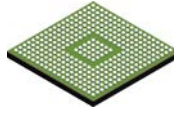

PACKAGE OUTLINE

NFBGA - 1.4 mm max height

PLASTIC BALL GRID ARRAY

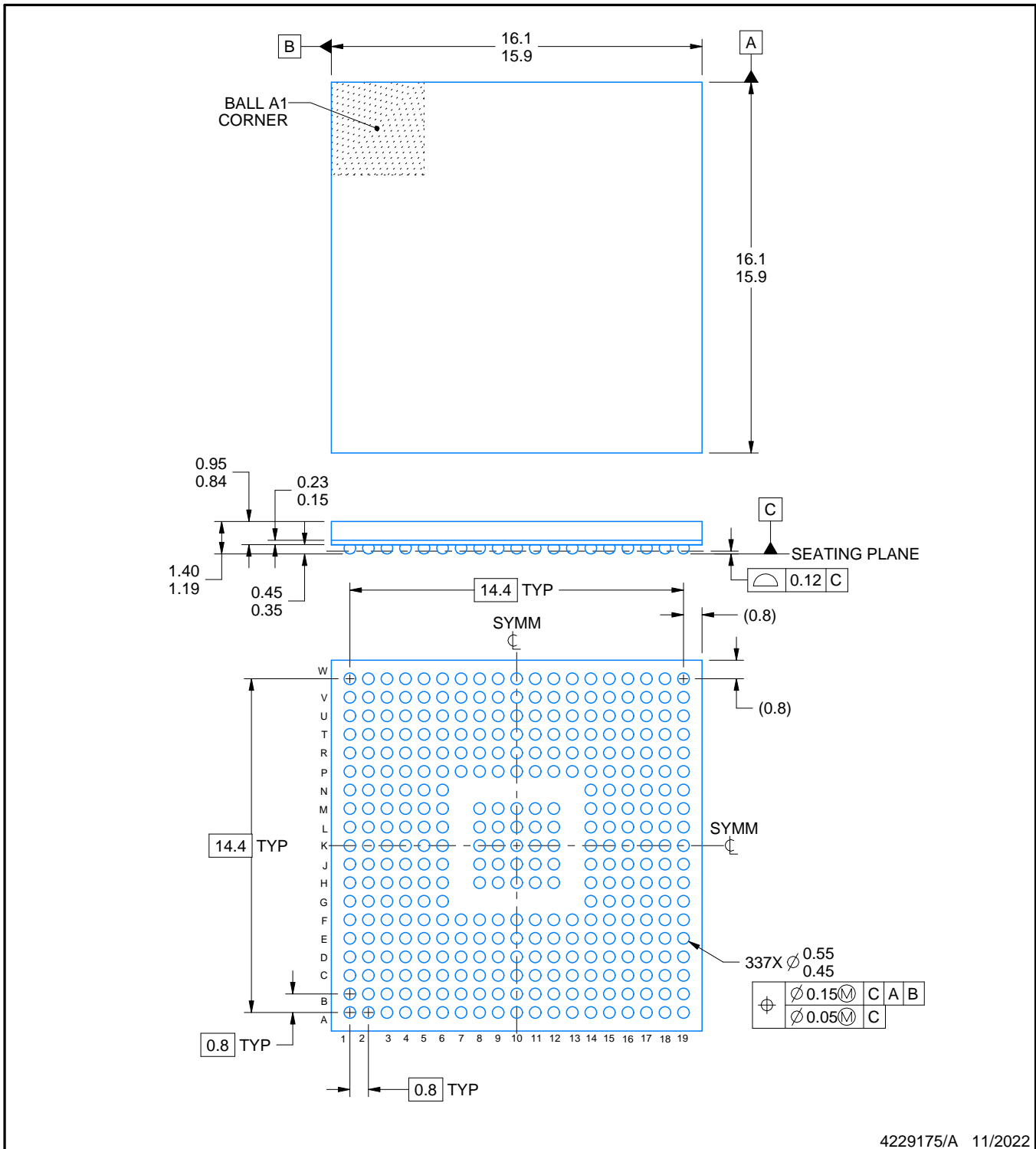

NOTES:

1. All linear dimensions are in millimeters. Any dimensions in parenthesis are for reference only. Dimensioning and tolerancing per ASME Y14.5M.
2. This drawing is subject to change without notice.

EXAMPLE BOARD LAYOUT

GWT0337A

NFBGA - 1.4 mm max height

PLASTIC BALL GRID ARRAY

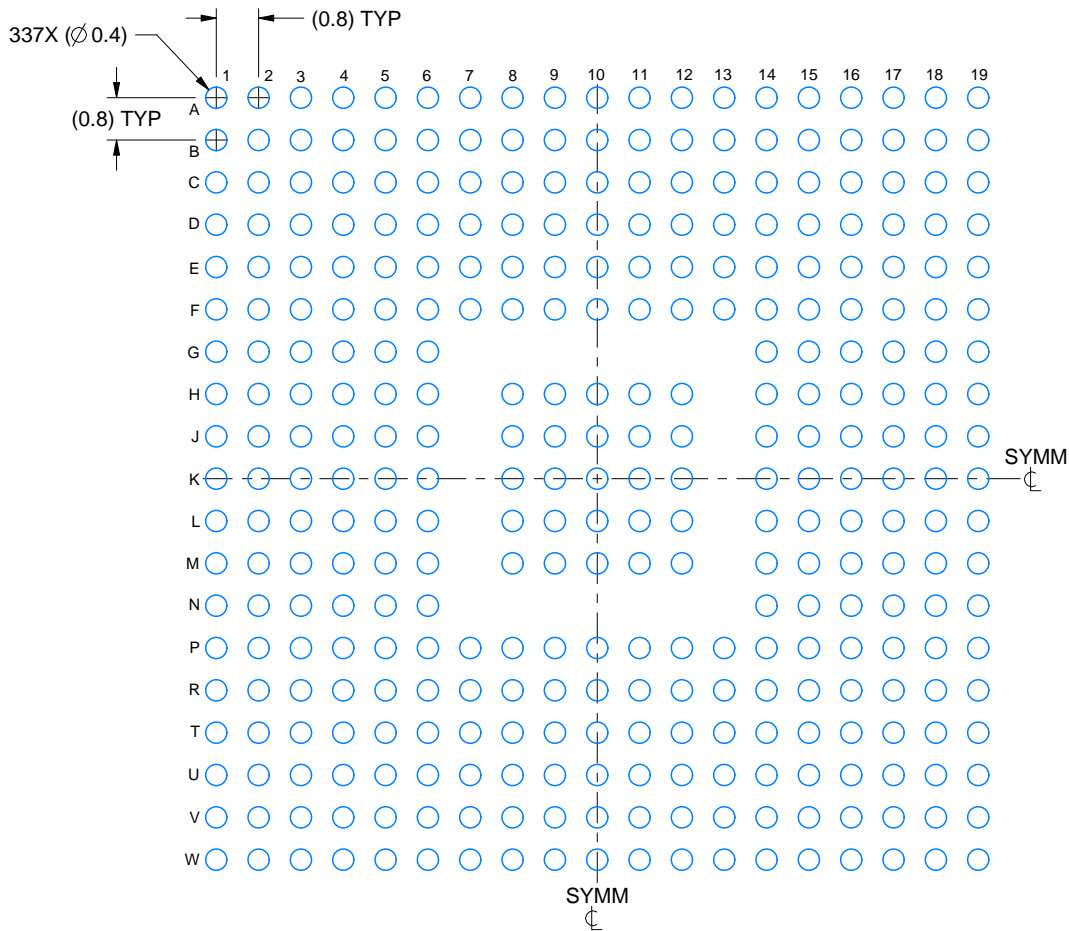

LAND PATTERN EXAMPLE
EXPOSED METAL SHOWN
SCALE: 7X

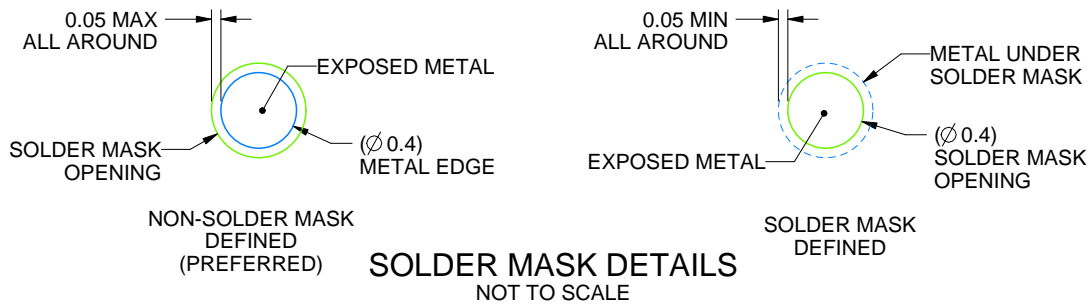

4229175/A 11/2022

NOTES: (continued)

- Final dimensions may vary due to manufacturing tolerance considerations and also routing constraints. For information, see Texas Instruments literature number SPRAA99 (www.ti.com/lit/spraa99).

EXAMPLE STENCIL DESIGN

GWT0337A

NFBGA - 1.4 mm max height

PLASTIC BALL GRID ARRAY

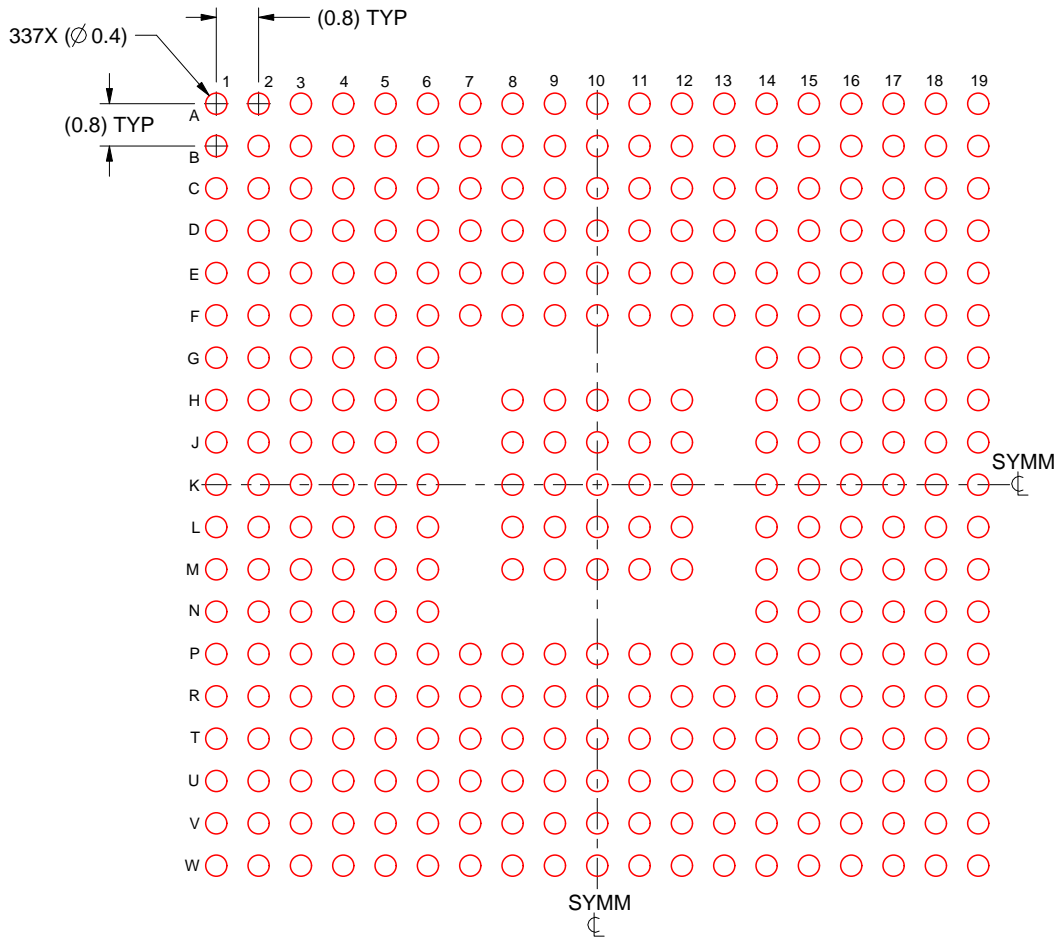

SOLDER PASTE EXAMPLE
BASED ON 0.150 mm THICK STENCIL
SCALE: 7X

4229175/A 11/2022

NOTES: (continued)

4. Laser cutting apertures with trapezoidal walls and rounded corners may offer better paste release.

PGE (S-PQFP-G144)

PLASTIC QUAD FLATPACK

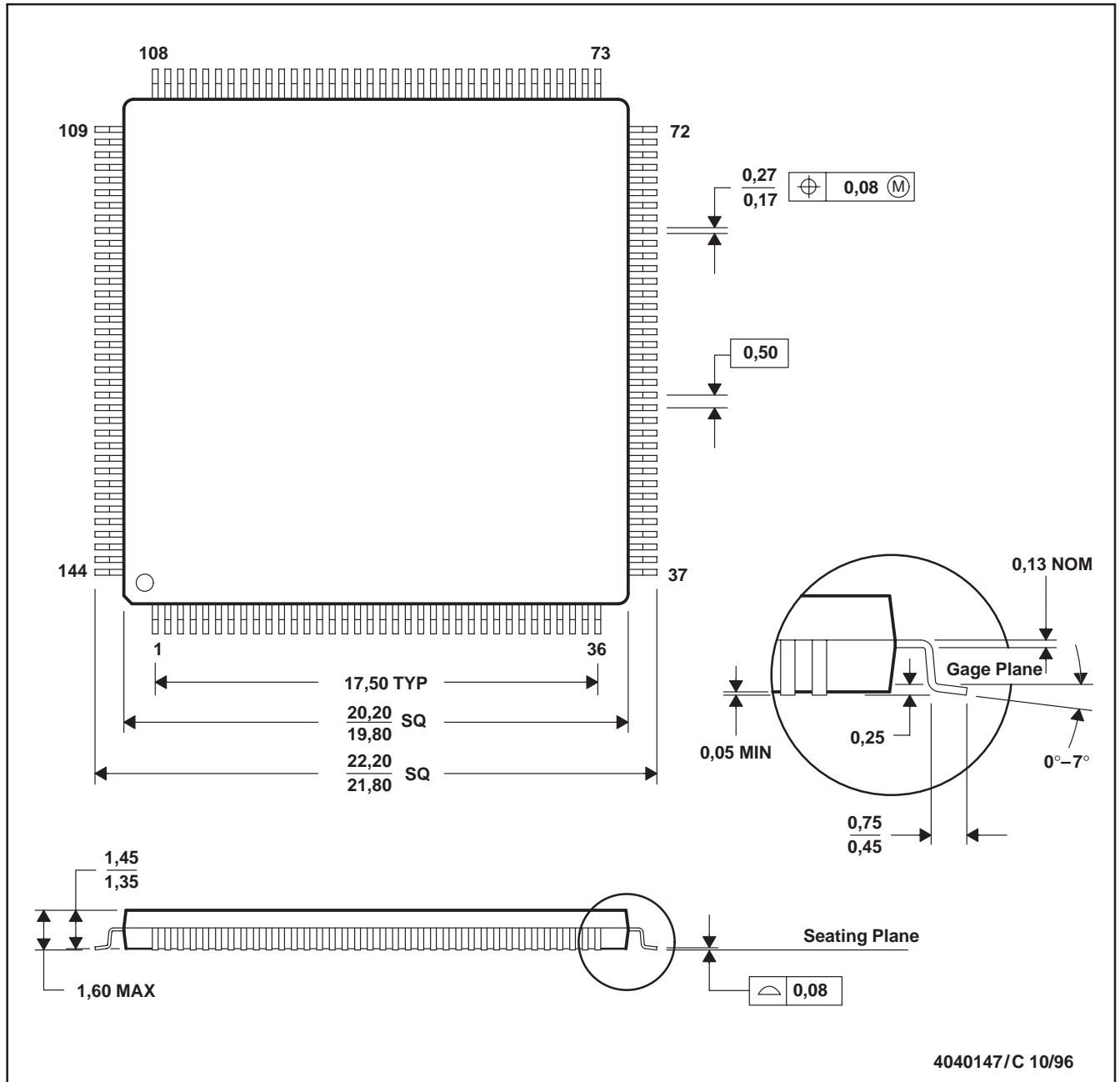

- NOTES: A. All linear dimensions are in millimeters.
 B. This drawing is subject to change without notice.
 C. Falls within JEDEC MS-026

重要声明和免责声明

TI“按原样”提供技术和可靠性数据（包括数据表）、设计资源（包括参考设计）、应用或其他设计建议、网络工具、安全信息和其他资源，不保证没有瑕疵且不做任何明示或暗示的担保，包括但不限于对适销性、某特定用途方面的适用性或不侵犯任何第三方知识产权的暗示担保。

这些资源可供使用 TI 产品进行设计的熟练开发人员使用。您将自行承担以下全部责任：(1) 针对您的应用选择合适的 TI 产品，(2) 设计、验证并测试您的应用，(3) 确保您的应用满足相应标准以及任何其他功能安全、信息安全、监管或其他要求。

这些资源如有变更，恕不另行通知。TI 授权您仅可将这些资源用于研发本资源所述的 TI 产品的应用。严禁对这些资源进行其他复制或展示。您无权使用任何其他 TI 知识产权或任何第三方知识产权。您应全额赔偿因在这些资源的使用中对 TI 及其代表造成的任何索赔、损害、成本、损失和债务，TI 对此概不负责。

TI 提供的产品受 [TI 的销售条款](#) 或 [ti.com](#) 上其他适用条款/TI 产品随附的其他适用条款的约束。TI 提供这些资源并不会扩展或以其他方式更改 TI 针对 TI 产品发布的适用的担保或担保免责声明。

TI 反对并拒绝您可能提出的任何其他或不同的条款。

邮寄地址：Texas Instruments, Post Office Box 655303, Dallas, Texas 75265

Copyright © 2022，德州仪器 (TI) 公司