

SN74AHC244Q 具有三态输出的八路缓冲器/驱动器

1 特性

- Q 器件满足汽车性能要求
- 可支持客户特殊配置控制与重大变更批准
- EPIC™ (增强性能植入式 CMOS) 工艺
- 工作电压范围为 2V 至 5.5V V_{CC}
- 闩锁性能超过 JESD 17 所规定的 250 mA

2 应用

- 启用或禁用数字信号
- 消除缓慢或嘈杂输入信号
- 在控制器复位期间保持信号
- 对开关进行去抖

3 说明

该八路缓冲器/驱动器专门设计用于提高三态存储器地址驱动器、时钟驱动器以及总线导向接收器和发送器的性能和密度。

封装信息

器件型号	封装 ⁽¹⁾	封装尺寸 (标称值)
SN74AHC14Q-Q1	D (SOIC, 14)	8.65 mm × 3.9 mm
	PW (TSSOP, 14)	5mm × 4.4mm

- (1) 封装图、标准包装数量、热数据、符号和 PCB 设计指南可从 www.ti.com/sc/package 获取。



Table of Contents

1 特性	1	8 Detailed Description	8
2 应用	1	8.1 Overview.....	8
3 说明	1	8.2 Functional Block Diagram.....	8
4 Revision History	2	8.3 Device Functional Modes.....	8
5 Function Table	3	9 Application and Implementation	9
6 Specifications	4	9.1 Power Supply Recommendations.....	9
6.1 Absolute Maximum Ratings.....	4	9.2 Layout.....	9
6.2 ESD Ratings.....	4	10 Device and Documentation Support	10
6.3 Recommended Operating Conditions.....	4	10.1 Documentation Support.....	10
6.4 Thermal Information.....	5	10.2 接收文档更新通知.....	10
6.5 Electrical Characteristics.....	5	10.3 支持资源.....	10
6.6 Switching Characteristics, $V_{CC} = 3.3\text{ V} \pm 0.3\text{ V}$	5	10.4 Trademarks.....	10
6.7 Switching Characteristics, $V_{CC} = 5\text{ V} \pm 0.5\text{ V}$	6	10.5 静电放电警告.....	10
6.8 Noise Characteristics.....	6	10.6 术语表.....	10
6.9 Operating Characteristics.....	6	11 Mechanical, Packaging, and Orderable Information	11
7 Parameter Measurement Information	7		

4 Revision History

注：以前版本的页码可能与当前版本的页码不同

Changes from Revision * (February 2002) to Revision A (April 2023)

Page

- 添加了应用、封装信息表、引脚功能表、ESD 等级表、热性能信息表、器件功能模式、应用和实施部分、电源相关建议部分、布局部分、器件和文档支持部分以及机械、封装和可订购信息部分..... **1**

5 Function Table



图 5-1. DW or PW Package (Top View)

表 5-1. Pin Functions

PIN		I/O	DESCRIPTION
NO.	NAME		
1	1 \overline{OE}	I	Output Enable 1
2	1A1	I	1A1 Input
3	2Y4	O	2Y4 Output
4	1A2	I	1A2 Input
5	2Y3	O	2Y3 Output
6	1A3	I	1A3 Input
7	2Y2	O	2Y2 Output
8	1A4	I	1A4 Input
9	2Y1	O	2Y1 Output
10	GND	—	Ground pin
11	2A1	I	2A1 Input
12	1Y4	O	1Y4 Output
13	2A2	I	2A2 Input
14	1Y3	O	1Y3 Output
15	2A3	I	2A3 Input
16	1Y2	O	1Y2 Output
17	2A4	I	2A4 Input
18	1Y1	O	1Y1 Output
19	2 \overline{OE}	I	Output Enable 2
20	VCC	—	Power Pin

6 Specifications

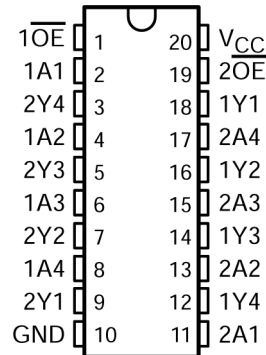
6.1 Absolute Maximum Ratings

over operating free-air temperature range (unless otherwise noted)¹

		MIN	MAX	UNIT
V_{CC}	Supply voltage range	- 0.5	7	V
V_I ²	Input voltage range	- 0.5	7	V
V_O ²	Output voltage range	- 0.5	$V_{CC} + 0.5$	V
I_{IK} ($V_I < 0$)	Input clamp current		- 20	mA
I_{OK} ($V_O < 0$ or $V_O > V_{CC}$)	Output clamp current		± 20	mA
I_O ($V_O = 0$ to V_{CC})	Continuous output current		± 25	mA
V_{CC} or GND	Continuous current		± 50	mA
T_{stg}	Storage temperature range	- 65	150	°C

1. Stresses beyond those listed under “absolute maximum ratings” may cause permanent damage to the device. These are stress ratings only, and functional operation of the device at these or any other conditions beyond those indicated under “recommended operating conditions” is not implied. Exposure to absolute-maximum-rated conditions for extended periods may affect device reliability.
2. The input and output voltage ratings may be exceeded if the input and output current ratings are observed.

6.2 ESD Ratings

		VALUE	UNIT
$V_{(ESD)}$	Electrostatic discharge	Human-Body Model (A114-A) ⁽¹⁾	± 1500
		Charged device model (CDM), per JEDEC specification JESD22-C101, all pins ⁽²⁾	± 1000
		Machine Model (A115-A)	± 200

(1) JEDEC document JEP155 states that 500-V HBM allows safe manufacturing with a standard ESD control process.

(2) JEDEC document JEP157 states that 250-V CDM allows safe manufacturing with a standard ESD control process.

6.3 Recommended Operating Conditions

(see Note⁽¹⁾)

		MIN	MAX	UNIT
V_{CC}	Supply voltage	2	5.5	V
V_{IH}	High-level input voltage	$V_{CC} = 2$ V	1.5	V
		$V_{CC} = 3$ V	2.1	
		$V_{CC} = 5.5$ V	3.85	
V_{IL}	Low-level input voltage	$V_{CC} = 2$ V	0.5	V
		$V_{CC} = 3$ V	0.9	
		$V_{CC} = 5.5$ V	1.65	
V_I	Input voltage	0	5.5	V
V_O	Output voltage	0	V_{CC}	V
I_{OH}	High-level output current	$V_{CC} = 2$ V	-50	μ A
		$V_{CC} = 3.3$ V ± 0.3 V	-4	mA
		$V_{CC} = 5$ V ± 0.5 V	-8	
I_{OL}	Low-level output current	$V_{CC} = 2$ V	50	μ A
		$V_{CC} = 3.3$ V ± 0.3 V	4	mA
		$V_{CC} = 5$ V ± 0.5 V	8	

(see Note⁽¹⁾)

		MIN	MAX	UNIT
$\Delta t / \Delta v$	Input transition rise or fall rate	$V_{CC} = 3.3 \text{ V} \pm 0.3 \text{ V}$	100	ns/V
		$V_{CC} = 5 \text{ V} \pm 0.5 \text{ V}$	20	
T_A	Operating free-air temperature	-40	125	°C

(1) All unused inputs of the device must be held at V_{CC} or GND to ensure proper device operation. Refer to the TI application report, *Implications of Slow or Floating CMOS Inputs*, literature number SCBA004.

6.4 Thermal Information

THERMAL METRIC ⁽¹⁾	SN74AHC244Q		UNIT
	DW	PW	
	20 PINS	20 PINS	
$R_{\theta JA}$	Junction-to-ambient thermal resistance		°C/W
	58	83	

(1) For more information about traditional and new thermal metrics, see the *IC Package Thermal Metrics* application report, [SPRA953](#).

6.5 Electrical Characteristics

over recommended operating free-air temperature range (unless otherwise noted)

PARAMETER	TEST CONDITIONS	V_{CC}	$T_A = 25^\circ\text{C}$			MIN	MAX	UNIT
			MIN	TYP	MAX			
V_{OH}	$I_{OH} = -50 \mu\text{A}$	2 V	1.9	2		1.9	V	
		3 V	2.9	3		2.9		
		4.5 V	4.4	4.5		4.4		
	$I_{OH} = -4 \text{ mA}$	3 V	2.58			2.48		
	$I_{OH} = -8 \text{ mA}$	4.5 V	3.94			3.8		
V_{OL}	$I_{OL} = 50 \mu\text{A}$	2 V			0.1		0.1	V
		3 V			0.1		0.1	
		4.5 V			0.1		0.1	
	$I_{OL} = 4 \text{ mA}$	3 V			0.36		0.5	
	$I_{OL} = 8 \text{ mA}$	4.5 V			0.36		0.5	
I_I	$V_I = 5.5 \text{ V}$ or GND	0 V to 5.5 V			± 0.1		± 1	μA
I_{OZ}	$V_O = V_{CC}$ or GND, $V_I (\text{OE}) = V_{IL}$ or V_{IH}	5.5 V			± 0.25		± 2.5	μA
I_{CC}	$V_I = V_{CC}$ or GND, $I_O = 0$	5.5 V			4		40	μA
C_i	$V_I = V_{CC}$ or GND	5 V		2	10			pF
C_o	$V_O = V_{CC}$ or GND	5 V		3.5				pF

6.6 Switching Characteristics, $V_{CC} = 3.3 \text{ V} \pm 0.3 \text{ V}$

over recommended operating free-air temperature range, $V_{CC} = 3.3 \text{ V} \pm 0.3 \text{ V}$ (unless otherwise noted) (see [Fig 7-1](#))

PARAMETER	FROM (INPUT)	TO (OUTPUT)	LOAD CAPACITANCE	$T_A = 25^\circ\text{C}$			MIN	MAX	UNIT
				MIN	TYP	MAX			
t_{PLH}	A	Y	$C_L = 15 \text{ pF}$		5.8	8.4	1	10	ns
t_{PHL}					5.8	8.4	1	10	
t_{PZH}	OE	Y	$C_L = 15 \text{ pF}$		6.6	10.6	1	12.5	ns
t_{PZL}					6.6	10.6	1	12.5	
t_{PHZ}	OE	Y	$C_L = 15 \text{ pF}$		5	9.7	1	11	ns
t_{PLZ}					5	9.7	1	11	
t_{PLH}	A	Y	$C_L = 50 \text{ pF}$		8.3	11.9	1	13.5	ns
t_{PHL}					8.3	11.9	1	13.5	

over recommended operating free-air temperature range, $V_{CC} = 3.3\text{ V} \pm 0.3\text{ V}$ (unless otherwise noted) (see [Figure 7-1](#))

PARAMETER	FROM (INPUT)	TO (OUTPUT)	LOAD CAPACITANCE	$T_A = 25^\circ\text{C}$			MIN	MAX	UNIT
				MIN	TYP	MAX			
t_{PZH}	\overline{OE}	Y	$C_L = 50\text{ pF}$		9.1	14.1	1	16	ns
t_{PZL}					9.1	14.1	1	16	
t_{PHZ}	\overline{OE}	Y	$C_L = 50\text{ pF}$		10.3	14	1	16	ns
t_{PLZ}					10.3	14	1	16	

6.7 Switching Characteristics, $V_{CC} = 5\text{ V} \pm 0.5\text{ V}$

over recommended operating free-air temperature range, $V_{CC} = 5\text{ V} \pm 0.5\text{ V}$ (unless otherwise noted) (see [Figure 7-1](#))

PARAMETER	FROM (INPUT)	TO (OUTPUT)	LOAD CAPACITANCE	$T_A = 25^\circ\text{C}$			MIN	MAX	UNIT
				MIN	TYP	MAX			
t_{PLH}	A	Y	$C_L = 15\text{ pF}$		3.9	5.5	1	6.5	ns
t_{PHL}					3.9	5.5	1	6.5	
t_{PZH}	\overline{OE}	Y	$C_L = 15\text{ pF}$		4.7	7.3	1	8.5	ns
t_{PZL}					4.7	7.3	1	8.5	
t_{PHZ}	\overline{OE}	Y	$C_L = 15\text{ pF}$		5	7.2	1	8.5	ns
t_{PLZ}					5	7.2	1	8.5	
t_{PLH}	A	Y	$C_L = 50\text{ pF}$		5.4	7.5	1	8.5	ns
t_{PHL}					5.4	7.5	1	8.5	
t_{PZH}	\overline{OE}	Y	$C_L = 50\text{ pF}$		6.2	9.3	1	10.5	ns
t_{PZL}					6.2	9.3	1	10.5	
t_{PHZ}	\overline{OE}	Y	$C_L = 50\text{ pF}$		6.7	9.2	1	10.5	ns
t_{PLZ}					6.7	9.2	1	10.5	

6.8 Noise Characteristics

$V_{CC} = 5\text{ V}$, $C_L = 50\text{ pF}$, $T_A = 25^\circ\text{C}$ ⁽¹⁾

PARAMETER	MIN	TYP	MAX	UNIT
$V_{OL(P)}$ Quiet output, maximum dynamic V_{OL}		0.5		V
$V_{OL(V)}$ Quiet output, minimum dynamic V_{OL}		-0.2		V
$V_{OH(V)}$ Quiet output, minimum dynamic V_{OH}		4.8		V
$V_{IH(D)}$ High-level dynamic input voltage	3.5			V
$V_{IL(D)}$ Low-level dynamic input voltage			1.5	V

(1) Characteristics are for surface-mount packages only.

6.9 Operating Characteristics

$V_{CC} = 5\text{ V}$, $T_A = 25^\circ\text{C}$

PARAMETER	TEST CONDITIONS	TYP	UNIT
C_{pd} Power dissipation capacitance	No load, $f = 1\text{ MHz}$	8.6	pF

7 Parameter Measurement Information

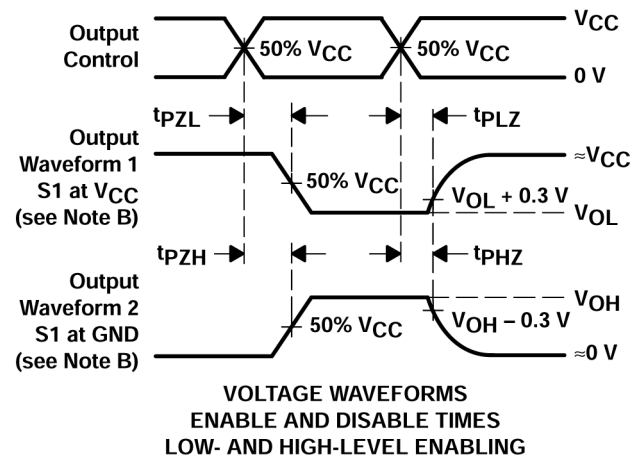
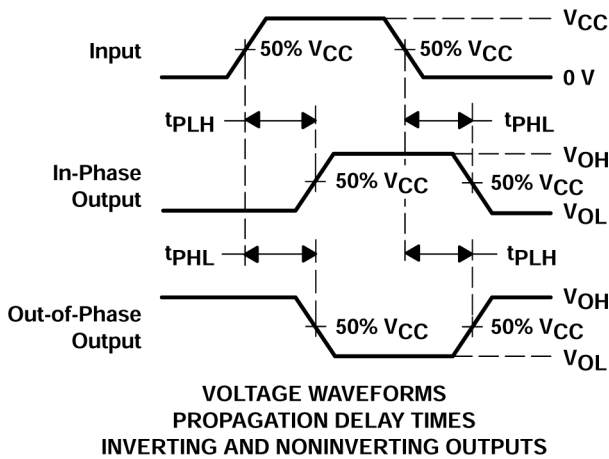
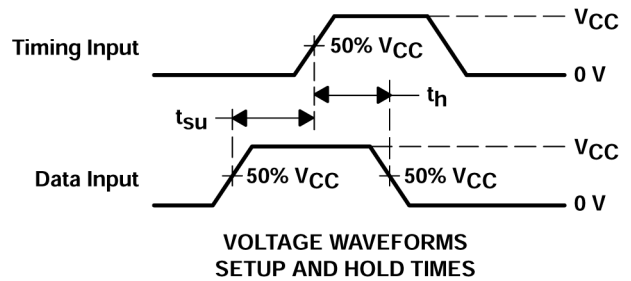
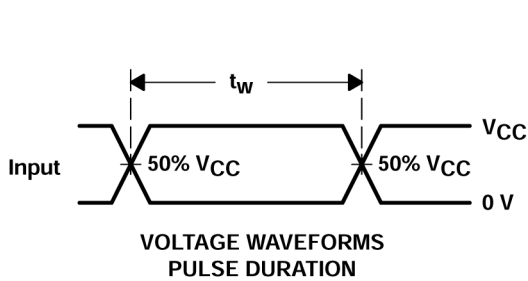
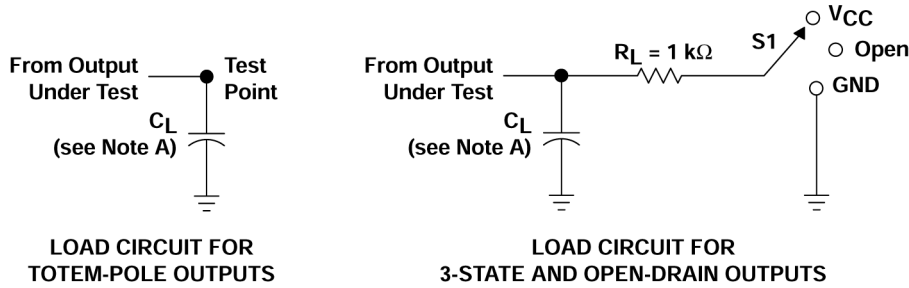

- A. C_L includes probe and jig capacitance.
- B. Waveform 1 is for an output with internal conditions such that the output is low except when disabled by the output control. Waveform 2 is for an output with internal conditions such that the output is high except when disabled by the output control.
- C. All input pulses are supplied by generators having the following characteristics: $PRR \leq 1\text{ MHz}$, $Z_O = 50\ \Omega$, $t_r \leq 3\text{ ns}$, $t_f \leq 3\text{ ns}$.
- D. The outputs are measured one at a time with one input transition per measurement.

图 7-1. Load Circuit and Voltage Waveforms

TEST	S1
t_{PLH}/t_{PHL}	Open
t_{PLZ}/t_{PZL}	V_{CC}
t_{PHZ}/t_{PZH}	GND
Open Drain	V_{CC}

8 Detailed Description

8.1 Overview

The SN74AHC244Q is organized as two 4-bit buffers/line drivers with separate output-enable (\overline{OE}) inputs. When \overline{OE} is low, the device passes data from the A inputs to the Y outputs. When \overline{OE} is high, the outputs are in the high-impedance state.

To ensure the high-impedance state during power up or power down, \overline{OE} should be tied to V_{CC} through a pullup resistor; the minimum value of the resistor is determined by the current-sinking capability of the driver.

8.2 Functional Block Diagram



图 8-1. Logic Diagram (Positive Logic)



图 8-2. Logic Symbol

8.3 Device Functional Modes

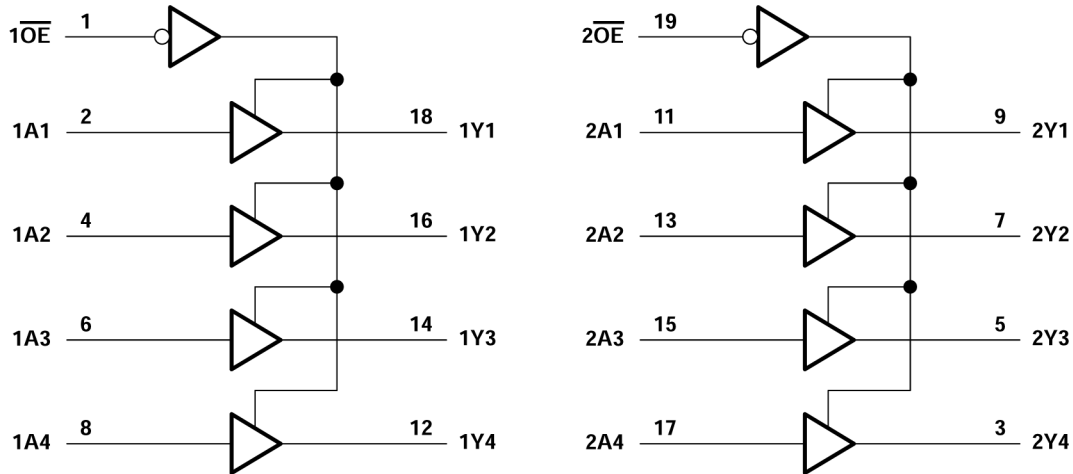
表 8-1. Function Table (Each 4-Bit Buffer/Driver)

INPUTS		OUTPUT
\overline{OE}	A	Y
L	H	H
L	L	L
H	X	Z

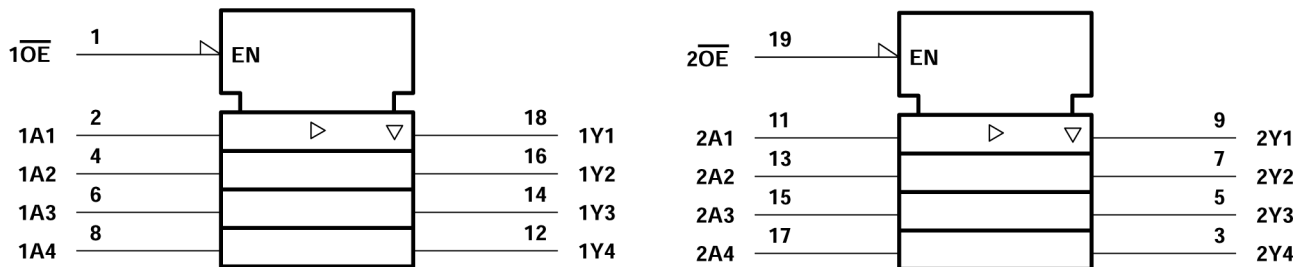
† This symbol is in accordance with ANSI/IEEE Std 91-1984 and IEC Publication 617-12.

9 Application and Implementation

备注

以下应用部分中的信息不属于 TI 器件规格的范围，TI 不担保其准确性和完整性。TI 的客户应负责确定器件是否适用于其应用。客户应验证并测试其设计，以确保系统功能。

9.1 Power Supply Recommendations

The power supply can be any voltage between the MIN and MAX supply voltage rating located in the [表 6.3](#) table.

Each VCC pin should have a good bypass capacitor to prevent power disturbance. For devices with a single supply, 0.1 μf is recommended; if there are multiple VCC pins, then 0.01 μf or 0.022 μf is recommended for each power pin. It is acceptable to parallel multiple bypass caps to reject different frequencies of noise. A 0.1 μf and a 1 μf are commonly used in parallel. The bypass capacitor should be installed as close to the power pin as possible for best results.

9.2 Layout

9.2.1 Layout Guidelines

When using multiple-bit logic devices, inputs should never float.

In many cases, functions or parts of functions of digital logic devices are unused, for example, when only two inputs of a triple-input AND gate are used or only 3 of the 4 buffer gates are used. Such input pins should not be left unconnected because the undefined voltages at the outside connections result in undefined operational states. [Layout Diagram](#) specifies the rules that must be observed under all circumstances. All unused inputs of digital logic devices must be connected to a high or low bias to prevent them from floating. The logic level that should be applied to any particular unused input depends on the function of the device. Generally they will be tied to GND or V_{CC}, whichever makes more sense or is more convenient. It is generally acceptable to float outputs, unless the part is a transceiver. If the transceiver has an output enable pin, it will disable the output section of the part when asserted. This will not disable the input section of the I/Os, so they cannot float when disabled.

9.2.1.1 Layout Example



图 9-1. Layout Diagram

10 Device and Documentation Support

10.1 Documentation Support

10.1.1 Related Documentation

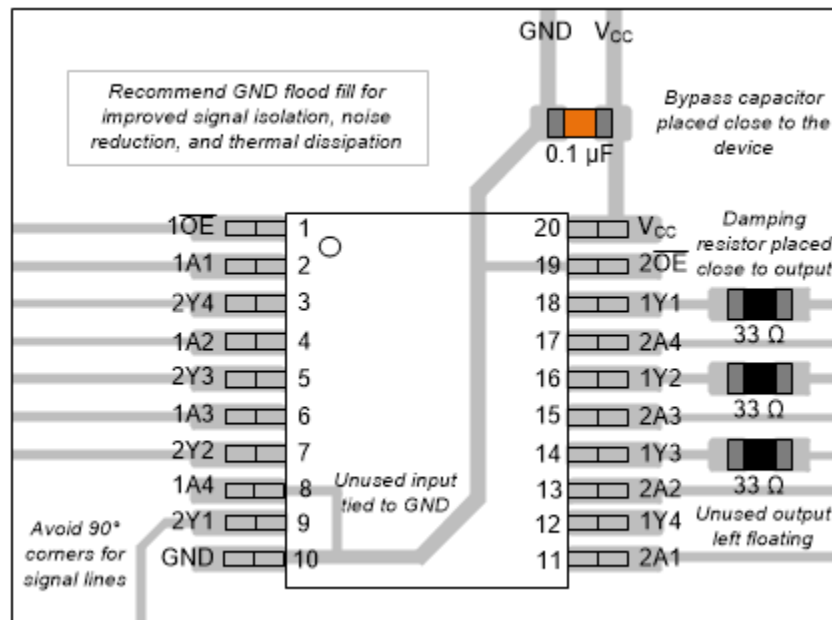
The table below lists quick access links. Categories include technical documents, support and community resources, tools and software, and quick access to sample or buy.

表 10-1. Related Links

PARTS	PRODUCT FOLDER	SAMPLE & BUY	TECHNICAL DOCUMENTS	TOOLS & SOFTWARE	SUPPORT & COMMUNITY
SN74AHC244Q	Click here	Click here	Click here	Click here	Click here

10.2 接收文档更新通知

要接收文档更新通知，请导航至 ti.com 上的器件产品文件夹。点击 [订阅更新](#) 进行注册，即可每周接收产品信息更改摘要。有关更改的详细信息，请查看任何已修订文档中包含的修订历史记录。

10.3 支持资源

TI E2E™ [支持论坛](#) 是工程师的重要参考资料，可直接从专家获得快速、经过验证的解答和设计帮助。搜索现有解答或提出自己的问题可获得所需的快速设计帮助。

链接的内容由各个贡献者“按原样”提供。这些内容并不构成 TI 技术规范，并且不一定反映 TI 的观点；请参阅 TI 的 [《使用条款》](#)。

10.4 Trademarks

TI E2E™ is a trademark of Texas Instruments.

所有商标均为其各自所有者的财产。

10.5 静电放电警告



静电放电 (ESD) 会损坏这个集成电路。德州仪器 (TI) 建议通过适当的预防措施处理所有集成电路。如果不遵守正确的处理和安装程序，可能会损坏集成电路。

ESD 的损坏小至导致微小的性能降级，大至整个器件故障。精密的集成电路可能更容易受到损坏，这是因为非常细微的参数更改都可能会导致器件与其发布的规格不相符。

10.6 术语表

[TI 术语表](#) 本术语表列出并解释了术语、首字母缩略词和定义。

11 Mechanical, Packaging, and Orderable Information

The following pages include mechanical, packaging, and orderable information. This information is the most current data available for the designated devices. This data is subject to change without notice and revision of this document. For browser-based versions of this data sheet, refer to the left-hand navigation.

PACKAGING INFORMATION

Orderable Device	Status (1)	Package Type	Package Drawing	Pins	Package Qty	Eco Plan (2)	Lead finish/ Ball material (6)	MSL Peak Temp (3)	Op Temp (°C)	Device Marking (4/5)	Samples
SN74AHC244QDWRG4	ACTIVE	SOIC	DW	20	2000	RoHS & Green	NIPDAU	Level-1-260C-UNLIM		AHC244Q	Samples
SN74AHC244QDWRG4Q1	ACTIVE	SOIC	DW	20	2000	RoHS & Green	NIPDAU	Level-1-260C-UNLIM		AHC244Q1	Samples
SN74AHC244QPWR	ACTIVE	TSSOP	PW	20	2000	RoHS & Green	NIPDAU	Level-1-260C-UNLIM	-40 to 125	HA244Q	Samples
SN74AHC244QPWRG4	ACTIVE	TSSOP	PW	20	2000	RoHS & Green	NIPDAU	Level-1-260C-UNLIM		HA244Q	Samples

(1) The marketing status values are defined as follows:

ACTIVE: Product device recommended for new designs.

LIFEBUY: TI has announced that the device will be discontinued, and a lifetime-buy period is in effect.

NRND: Not recommended for new designs. Device is in production to support existing customers, but TI does not recommend using this part in a new design.

PREVIEW: Device has been announced but is not in production. Samples may or may not be available.

OBSOLETE: TI has discontinued the production of the device.

(2) **RoHS:** TI defines "RoHS" to mean semiconductor products that are compliant with the current EU RoHS requirements for all 10 RoHS substances, including the requirement that RoHS substance do not exceed 0.1% by weight in homogeneous materials. Where designed to be soldered at high temperatures, "RoHS" products are suitable for use in specified lead-free processes. TI may reference these types of products as "Pb-Free".

RoHS Exempt: TI defines "RoHS Exempt" to mean products that contain lead but are compliant with EU RoHS pursuant to a specific EU RoHS exemption.

Green: TI defines "Green" to mean the content of Chlorine (Cl) and Bromine (Br) based flame retardants meet JS709B low halogen requirements of <=1000ppm threshold. Antimony trioxide based flame retardants must also meet the <=1000ppm threshold requirement.

(3) MSL, Peak Temp. - The Moisture Sensitivity Level rating according to the JEDEC industry standard classifications, and peak solder temperature.

(4) There may be additional marking, which relates to the logo, the lot trace code information, or the environmental category on the device.

(5) Multiple Device Markings will be inside parentheses. Only one Device Marking contained in parentheses and separated by a "-" will appear on a device. If a line is indented then it is a continuation of the previous line and the two combined represent the entire Device Marking for that device.

(6) Lead finish/Ball material - Orderable Devices may have multiple material finish options. Finish options are separated by a vertical ruled line. Lead finish/Ball material values may wrap to two lines if the finish value exceeds the maximum column width.

Important Information and Disclaimer:The information provided on this page represents TI's knowledge and belief as of the date that it is provided. TI bases its knowledge and belief on information provided by third parties, and makes no representation or warranty as to the accuracy of such information. Efforts are underway to better integrate information from third parties. TI has taken and

continues to take reasonable steps to provide representative and accurate information but may not have conducted destructive testing or chemical analysis on incoming materials and chemicals. TI and TI suppliers consider certain information to be proprietary, and thus CAS numbers and other limited information may not be available for release.

In no event shall TI's liability arising out of such information exceed the total purchase price of the TI part(s) at issue in this document sold by TI to Customer on an annual basis.

TAPE AND REEL INFORMATION

QUADRANT ASSIGNMENTS FOR PIN 1 ORIENTATION IN TAPE

*All dimensions are nominal

Device	Package Type	Package Drawing	Pins	SPQ	Reel Diameter (mm)	Reel Width W1 (mm)	A0 (mm)	B0 (mm)	K0 (mm)	P1 (mm)	W (mm)	Pin1 Quadrant
SN74AHC244QDWRG4	SOIC	DW	20	2000	330.0	24.4	10.8	13.3	2.7	12.0	24.0	Q1
SN74AHC244QDWRG4Q1	SOIC	DW	20	2000	330.0	24.4	10.8	13.3	2.7	12.0	24.0	Q1
SN74AHC244QPWR	TSSOP	PW	20	2000	330.0	16.4	6.95	7.0	1.4	8.0	16.0	Q1
SN74AHC244QPWRG4	TSSOP	PW	20	2000	330.0	16.4	6.95	7.0	1.4	8.0	16.0	Q1

TAPE AND REEL BOX DIMENSIONS

*All dimensions are nominal

Device	Package Type	Package Drawing	Pins	SPQ	Length (mm)	Width (mm)	Height (mm)
SN74AHC244QDWRG4	SOIC	DW	20	2000	367.0	367.0	45.0
SN74AHC244QDWRG4Q1	SOIC	DW	20	2000	367.0	367.0	45.0
SN74AHC244QPWR	TSSOP	PW	20	2000	356.0	356.0	35.0
SN74AHC244QPWRG4	TSSOP	PW	20	2000	356.0	356.0	35.0

PW0020A



PACKAGE OUTLINE

TSSOP - 1.2 mm max height

SMALL OUTLINE PACKAGE



4220206/A 02/2017

NOTES:

- All linear dimensions are in millimeters. Any dimensions in parenthesis are for reference only. Dimensioning and tolerancing per ASME Y14.5M.
- This drawing is subject to change without notice.
- This dimension does not include mold flash, protrusions, or gate burrs. Mold flash, protrusions, or gate burrs shall not exceed 0.15 mm per side.
- This dimension does not include interlead flash. Interlead flash shall not exceed 0.25 mm per side.
- Reference JEDEC registration MO-153.

EXAMPLE BOARD LAYOUT

PW0020A

TSSOP - 1.2 mm max height

SMALL OUTLINE PACKAGE



LAND PATTERN EXAMPLE
EXPOSED METAL SHOWN
SCALE: 10X



4220206/A 02/2017

NOTES: (continued)

- 6. Publication IPC-7351 may have alternate designs.
- 7. Solder mask tolerances between and around signal pads can vary based on board fabrication site.

EXAMPLE STENCIL DESIGN

PW0020A

TSSOP - 1.2 mm max height

SMALL OUTLINE PACKAGE



SOLDER PASTE EXAMPLE
BASED ON 0.125 mm THICK STENCIL
SCALE: 10X

4220206/A 02/2017

NOTES: (continued)

8. Laser cutting apertures with trapezoidal walls and rounded corners may offer better paste release. IPC-7525 may have alternate design recommendations.
9. Board assembly site may have different recommendations for stencil design.

PW (R-PDSO-G20)

PLASTIC SMALL OUTLINE



- NOTES:
- A. All linear dimensions are in millimeters.
 - B. This drawing is subject to change without notice.
 - C. Publication IPC-7351 is recommended for alternate design.
 - D. Laser cutting apertures with trapezoidal walls and also rounding corners will offer better paste release. Customers should contact their board assembly site for stencil design recommendations. Refer to IPC-7525 for other stencil recommendations.
 - E. Customers should contact their board fabrication site for solder mask tolerances between and around signal pads.

DW0020A



PACKAGE OUTLINE

SOIC - 2.65 mm max height

SOIC



4220724/A 05/2016

NOTES:

- All linear dimensions are in millimeters. Dimensions in parenthesis are for reference only. Dimensioning and tolerancing per ASME Y14.5M.
- This drawing is subject to change without notice.
- This dimension does not include mold flash, protrusions, or gate burrs. Mold flash, protrusions, or gate burrs shall not exceed 0.15 mm per side.
- This dimension does not include interlead flash. Interlead flash shall not exceed 0.43 mm per side.
- Reference JEDEC registration MS-013.

EXAMPLE BOARD LAYOUT

DW0020A

SOIC - 2.65 mm max height

SOIC



LAND PATTERN EXAMPLE
SCALE:6X



SOLDER MASK DETAILS

4220724/A 05/2016

NOTES: (continued)

- 6. Publication IPC-7351 may have alternate designs.
- 7. Solder mask tolerances between and around signal pads can vary based on board fabrication site.

EXAMPLE STENCIL DESIGN

DW0020A

SOIC - 2.65 mm max height

SOIC



SOLDER PASTE EXAMPLE
BASED ON 0.125 mm THICK STENCIL
SCALE:6X

4220724/A 05/2016

NOTES: (continued)

8. Laser cutting apertures with trapezoidal walls and rounded corners may offer better paste release. IPC-7525 may have alternate design recommendations.
9. Board assembly site may have different recommendations for stencil design.

重要声明和免责声明

TI“按原样”提供技术和可靠性数据（包括数据表）、设计资源（包括参考设计）、应用或其他设计建议、网络工具、安全信息和其他资源，不保证没有瑕疵且不做任何明示或暗示的担保，包括但不限于对适销性、某特定用途方面的适用性或不侵犯任何第三方知识产权的暗示担保。

这些资源可供使用 TI 产品进行设计的熟练开发人员使用。您将自行承担以下全部责任：(1) 针对您的应用选择合适的 TI 产品，(2) 设计、验证并测试您的应用，(3) 确保您的应用满足相应标准以及任何其他功能安全、信息安全、监管或其他要求。

这些资源如有变更，恕不另行通知。TI 授权您仅可将这些资源用于研发本资源所述的 TI 产品的应用。严禁对这些资源进行其他复制或展示。您无权使用任何其他 TI 知识产权或任何第三方知识产权。您应全额赔偿因在这些资源的使用中对 TI 及其代表造成的任何索赔、损害、成本、损失和债务，TI 对此概不负责。

TI 提供的产品受 [TI 的销售条款](#) 或 [ti.com](#) 上其他适用条款/TI 产品随附的其他适用条款的约束。TI 提供这些资源并不会扩展或以其他方式更改 TI 针对 TI 产品发布的适用的担保或担保免责声明。

TI 反对并拒绝您可能提出的任何其他或不同的条款。

邮寄地址：Texas Instruments, Post Office Box 655303, Dallas, Texas 75265

Copyright © 2023，德州仪器 (TI) 公司