

TPS2379 具有外部栅极驱动器的 IEEE 802.3at PoE 高功率 PD 接口

1 特性

- 带有状态标志的 IEEE 802.3at 2 类硬件分类
- 辅助栅极驱动器，用于高功率扩展
- 稳健耐用的 100V、0.5Ω 热插拔金属氧化物半导体场效应晶体管 (MOSFET)
- 1A (典型值) 工作电流限值
- 140mA (典型值) 浪涌电流限值
- DC-DC 转换器使能
- 15kV/8kV 系统级静电放电 (ESD) 功能
- PowerPAD™HSOP 封装

2 应用

- 符合 IEEE 802.3at 标准的器件
- 通用以太网供电 (UPOE) 兼容器件
- 视频和网络语音 (VoIP) 电话
- 多频带访问点
- 监控摄像机
- 微微基站

3 说明

TPS2379 器件是一款 8 引脚集成电路，包含实现 IEEE802.3at 2 类受电设备 (PD) 所需的全部功能，例如检测、分类、2 类硬件分类以及启动时的 140 mA 浪涌电流限制。该控制器的内部开关电阻低至 0.5Ω，并且采用耐热增强型 PowerPAD 封装，因此能够长时间在高达 0.85A 的电流下运行。TPS2379 集成的内部开关电阻低至 0.5Ω，这使得 PD 能够在正常运行时长时间承受高达 0.85A 的电流。TPS2379 器件支持高功率应用，但需要外接导通晶体管。TPS2379 包含多项保护功能，例如热关断、折返电流限制以及稳健耐用的 100V 内部开关。

器件信息(1)

器件型号	封装	封装尺寸 (标称值)
TPS2379	HSOP (8)	4.89mm × 3.90mm

(1) 要了解所有可用封装，请参见数据表末尾的可订购产品附录。

典型应用电路

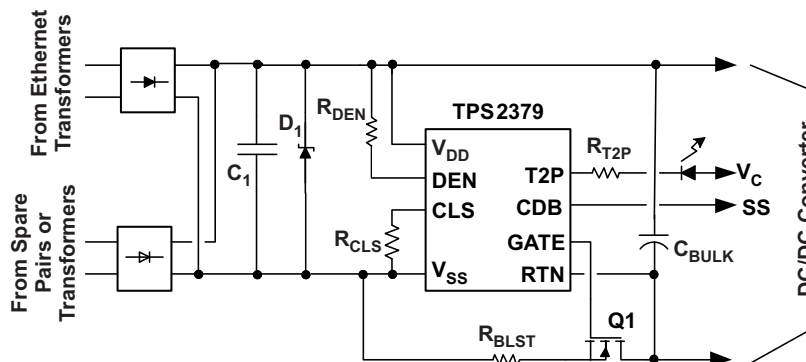

目录

<ul style="list-style-type: none"> 1 特性 1 2 应用 1 3 说明 1 4 修订历史记录 2 5 Pin Configuration and Functions 3 6 Specifications 4 <ul style="list-style-type: none"> 6.1 Absolute Maximum Ratings 4 6.2 ESD Ratings 4 6.3 Recommended Operating Conditions 4 6.4 Thermal Information 5 6.5 Electrical Characteristics 5 6.6 Typical Characteristics 7 7 Parameter Measurement Information 9 8 Detailed Description 10 <ul style="list-style-type: none"> 8.1 Overview 10 8.2 Functional Block Diagram 10 8.3 Feature Description 10 	<ul style="list-style-type: none"> 8.4 Device Functional Modes 14 9 Application and Implementation 22 <ul style="list-style-type: none"> 9.1 Application Information 22 9.2 Typical Application 22 10 Power Supply Recommendations 25 11 Layout 25 <ul style="list-style-type: none"> 11.1 Layout Guidelines 25 11.2 Layout Example 26 11.3 Thermal Considerations and OTSD 28 11.4 ESD 28 12 器件和文档支持 29 <ul style="list-style-type: none"> 12.1 文档支持 29 12.2 社区资源 29 12.3 商标 29 12.4 静电放电警告 29 12.5 Glossary 29 13 机械、封装和可订购信息 29
--	---

4 修订历史记录

注：之前版本的页码可能与当前版本有所不同。

Changes from Original (March 2012) to Revision A	Page
• 已添加 ESD 额定值表，特性描述部分，器件功能模式，应用和实施部分，电源相关建议部分，布局部分，器件和文档支持部分以及机械、封装和可订购信息部分	1
• Deleted <i>Classification Resistor, RCLS</i> section	13
• Deleted <i>CDB Pin Interface</i> section	13
• Deleted <i>GATE Pin Interface</i> section	13
• Deleted <i>External Boost Circuit (Q1, Q2, and R_{BLST}) Considerations</i> section	13
• Deleted T2P Pin Interface	13
• Deleted <i>Detailed Pin Descriptions</i> section	21

5 Pin Configuration and Functions

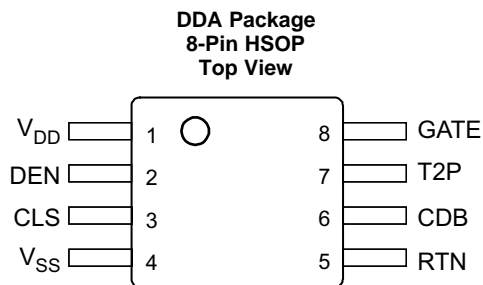

Pin Functions

PIN		I/O	DESCRIPTION
NAME	NO.		
V _{DD}	1	I	Connect to positive PoE input power rail. Bypass with 0.1 μF to V _{SS} .
DEN	2	I/O	Connect 24.9 kΩ to V _{DD} for detection. Pull to V _{SS} disable pass MOSFET.
CLS	3	O	Connect resistor from CLS to V _{SS} to program classification current.
V _{SS}	4	—	Connect to negative power rail derived from PoE source.
RTN	5	O	Drain of PoE pass MOSFET.
CDB	6	O	Opndrain converter disable output, active low, referenced to RTN.
T2P	7	O	Active low indicates type 2 PSE connected.
GATE	8	O	Auxiliary gate driver output.
PowerPAD	—	—	The PowerPAD must be connected to V _{SS} . A large fill area is required to assist in heat dissipation.

6 Specifications

6.1 Absolute Maximum Ratings

 over operating free-air temperature range (unless otherwise noted) ⁽¹⁾

		MIN	MAX	UNIT
Input voltage	V _{DD} , DEN	-0.3	100	V
	RTN ⁽²⁾	-0.6	100	
	CLS ⁽³⁾	-0.3	6.5	
	GATE ⁽³⁾	-0.3	18	
	[CDB, T2P] to RTN	-0.3	100	
Sinking current	RTN ⁽⁴⁾	Internally limited		mA
	CDB, T2P	5		
	DEN	1		
Sourcing current	CLS	65		mA
T _{JMAX}		Internally limited		°C
Storage temperature, T _{stg}		-65	150	°C

- (1) Stresses beyond those listed under *Absolute Maximum Ratings* may cause permanent damage to the device. These are stress ratings only, which do not imply functional operation of the device at these or any other conditions beyond those indicated under *Recommended Operating Conditions*. Exposure to absolute-maximum-rated conditions for extended periods may affect device reliability.
- (2) With I(RTN) = 0
- (3) Do not apply voltages to these pins
- (4) SOA limited to RTN = 80 V at 1.2 A.

6.2 ESD Ratings

		VALUE	UNIT
V _(ESD) Electrostatic discharge	Human body model (HBM), per ANSI/ESDA/JEDEC JS-001, all pins ⁽¹⁾	2000	V
	Charged device model (CDM), per JEDEC specification JESD22-C101, all pins ⁽²⁾	500	
	IEC 61000-4-2 contact discharge ⁽³⁾	8000	
	IEC 61000-4-2 air-gap discharge ⁽³⁾	15000	

- (1) JEDEC document JEP155 states that 500-V HBM allows safe manufacturing with a standard ESD control process.
- (2) JEDEC document JEP157 states that 250-V CDM allows safe manufacturing with a standard ESD control process.
- (3) Discharges applied to circuit of [Figure 26](#) between RJ-45, adapter, and output voltage rails.

6.3 Recommended Operating Conditions

 Voltages with respect to V_{SS} (unless otherwise noted)

		MIN	NOM	MAX	UNIT
Input voltage range	RTN, V _{DD}	0		57	V
	T2P or CDB to RTN	0		57	
Sinking current	RTN			0.85	A
	CDB, T2P			2	mA
Resistance	CLS ⁽¹⁾	60			Ω
Junction temperature		-40		125	°C

- (1) Voltage should not be externally applied to this pin.

6.4 Thermal Information

THERMAL METRIC ⁽¹⁾		TPS2379		UNIT
		DDA (HSOP)		
		8 PINS		
R _{θJA}	Junction-to-ambient thermal resistance	45.9		°C/W
R _{θJC(top)}	Junction-to-case (top) thermal resistance	51.9		°C/W
R _{θJB}	Junction-to-board thermal resistance	28.8		°C/W
ψ _{JT}	Junction-to-top characterization parameter	8.9		°C/W
ψ _{JB}	Junction-to-board characterization parameter	28.7		°C/W
R _{θJC(bot)}	Junction-to-case (bottom) thermal resistance	6.7		°C/W

(1) For more information about traditional and new thermal metrics, see the *Semiconductor and IC Package Thermal Metrics* application report, [SPRA953](#).

6.5 Electrical Characteristics

40 V ≤ V_{VDD} ≤ 57 V, R_{DEN} = 24.9 kΩ, CDB, CLS, GATE, T2P open; –40°C ≤ T_J ≤ 125°C. Positive currents are into pins. Typical values are at 25°C. All voltages are with respect to V_{VSS} (unless otherwise noted)

PARAMETER		TEST CONDITIONS	MIN	TYP	MAX	UNIT
DETECTION (DEN)						
Detection current		Measure I _{SUPPLY} (VDD, RTN, DEN)				μA
		V _{DD} = 1.4 V	53.8	56.5	58.3	
		V _{DD} = 10.1 V, Not in mark	395	410	417	
Bias current		DEN open, V _{VDD} = 10.1 V, Measure I _{SUPPLY} , Not in mark	3	4.8	12	μA
V _{PD_DIS}	Disable threshold	DEN falling	3	3.7	5	V
	Hysteresis		50	113	200	mV
CLASSIFICATION (CLS)						
I _{CLS} Classification current		13 V ≤ V _{DD} ≤ 21 V, Measure I _{VDD} + I _{DEN} + I _{RTN}				mA
		R _{CLS} = 1270 Ω	1.8	2.17	2.6	
		R _{CLS} = 243 Ω	9.9	10.6	11.2	
		R _{CLS} = 137 Ω	17.6	18.6	19.4	
		R _{CLS} = 90.9 Ω	26.5	27.9	29.3	
V _{CL_ON} Class lower threshold		V _{DD} rising, V _{CLS} ↑	11.9	12.5	13	V
		Hysteresis	1.4	1.6	1.7	
V _{CU_ON} Class upper threshold		V _{DD} rising, V _{CLS} ↓	21	22	23	V
		Hysteresis	0.5	0.78	0.9	
V _{MSR}	Mark reset threshold	V _{VDD} falling	3	3.9	5	
Mark state resistance		2-point measurement at 5 V and 10.1 V	6	10	12	kΩ
Leakage current		V _{DD} = 57 V, V _{CLS} = 0 V, measure I _{CLS}			1	μA
GATE (AUXILIARY GATE OUTPUT)						
Output high voltage			8	10	12	V
Sourcing current		V _{GATE} = 0 V	25	38	60	μA
Sinking current		V _{GATE} = 4 V, V _{DD} = 48 → 25 V	0.6	1.25	1.75	mA
		V _{DD} = 25 V, V _{GATE} = 0 → 4 V	5	23.2	30	
Current limit delay			150	365	600	μs
PASS DEVICE (RTN)						
r _{DS(ON)}	On resistance		0.2	0.42	0.75	Ω
Input bias current		V _{DD} = V _{RTN} = 30 V, measure I _{RTN}			30	μA
Current limit		V _{RTN} = 1.5 V	0.85	1	1.2	A
Inrush current limit		V _{RTN} = 2 V, V _{DD} : 20 V → 48 V	100	140	180	mA

Electrical Characteristics (continued)

$40\text{ V} \leq V_{\text{VDD}} \leq 57\text{ V}$, $R_{\text{DEN}} = 24.9\text{ k}\Omega$, CDB, CLS, GATE, T2P open; $-40^\circ\text{C} \leq T_{\text{J}} \leq 125^\circ\text{C}$. Positive currents are into pins.
 Typical values are at 25°C . All voltages are with respect to V_{VSS} (unless otherwise noted)

PARAMETER		TEST CONDITIONS	MIN	TYP	MAX	UNIT
	Inrush termination	Percentage of inrush current	80%	90%	99%	
	Foldback threshold	V_{RTN} rising	11	12.3	13.6	V
	Foldback deglitch time	V_{RTN} rising to when current limit changes to inrush current limit	500	800	1500	μs
CONVERTER DISABLE (CDB)						
	Output low voltage	$I_{\text{CDB}} = 2\text{ mA}$, $V_{\text{RTN}} = 2\text{ V}$, $V_{\text{DD}}: 20\text{ V} \rightarrow 48\text{ V}$		0.27	0.50	V
	Minimum voltage, $V_{(\text{VDD} - \text{RTN})}$, for CDB to be valid	$V_{\text{CDB}} = V_{\text{DD}}$, $I_{\text{CDB}} = 1\text{ mA}$, in inrush		3		V
	Leakage current	$V_{\text{CDB}} = 57\text{ V}$, $V_{\text{RTN}} = 0\text{ V}$			10	μA
TYPE 2 PSE INDICATION (T2P)						
V_{T2P}	Output low voltage	$I_{\text{T2P}} = 2\text{ mA}$, after 2-event classification and inrush is complete, $V_{\text{RTN}} = 0\text{ V}$		0.26	0.60	V
	Leakage current	$V_{\text{T2P}} = 57\text{ V}$, $V_{\text{RTN}} = 0\text{ V}$			10	μA
UVLO						
$V_{\text{UVLO_R}}$	UVLO rising threshold	V_{VDD} rising	36.3	38.1	40	V
	UVLO falling threshold	V_{VDD} falling	30.5	32	33.6	
$V_{\text{UVLO_H}}$	UVLO hysteresis			6.1		V
THERMAL SHUTDOWN						
	Shutdown	$T_{\text{J}} \uparrow$	135	145		$^\circ\text{C}$
	Hysteresis			20		
V_{DD} BIAS CURRENT						
	Operating current	$40\text{ V} \leq V_{\text{VDD}} \leq 57\text{ V}$		285	500	μA

6.6 Typical Characteristics

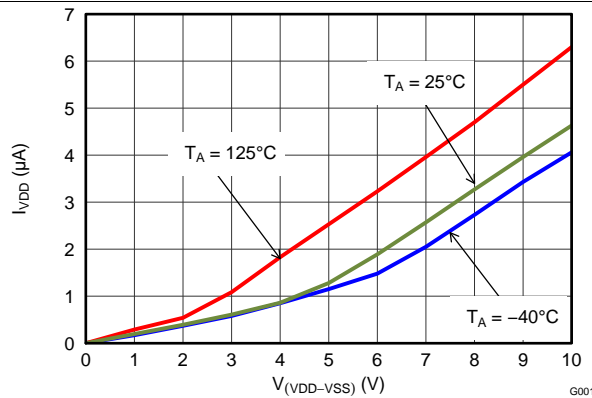

Figure 1. Detection Bias Current vs PoE Voltage

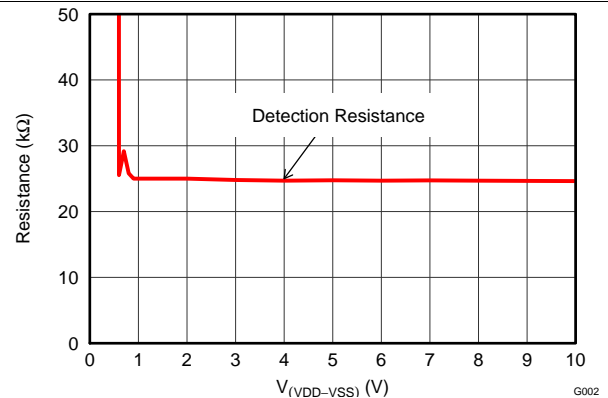

Figure 2. Detection Resistance vs PoE Voltage

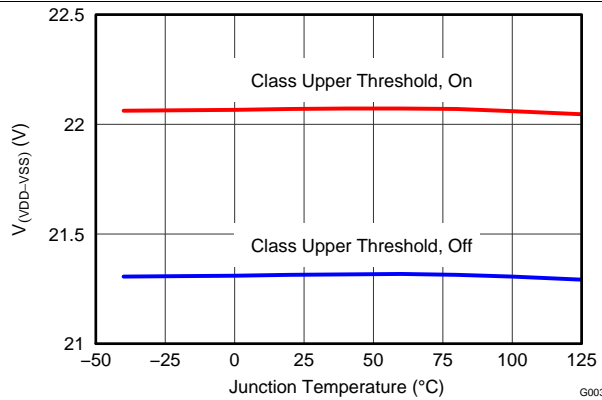

Figure 3. Classification Upper Threshold vs Temperature

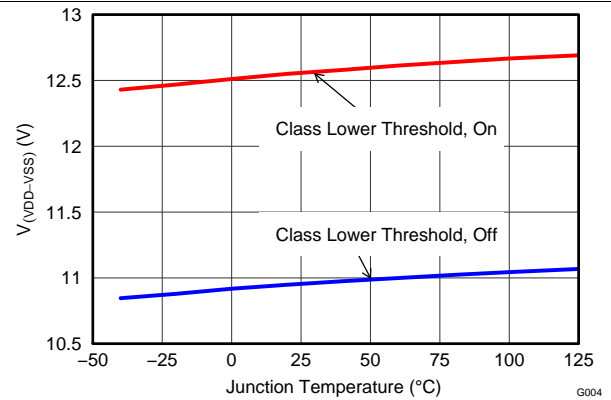

Figure 4. Classification Lower Threshold vs Temperature

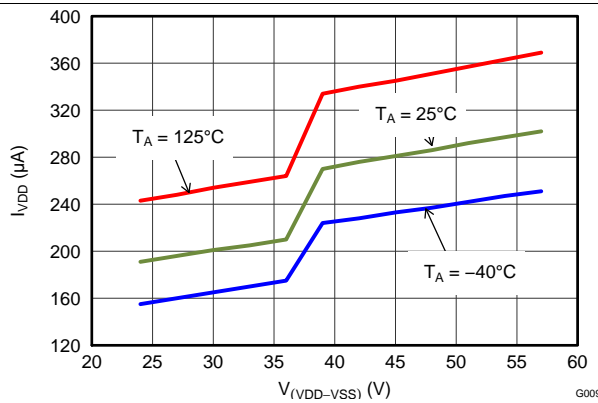

Figure 5. IVDD Bias Current vs Voltage

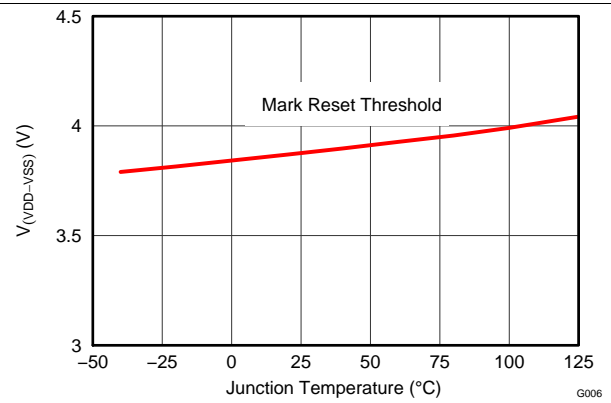

Figure 6. Mark Reset Threshold vs Temperature

Typical Characteristics (continued)

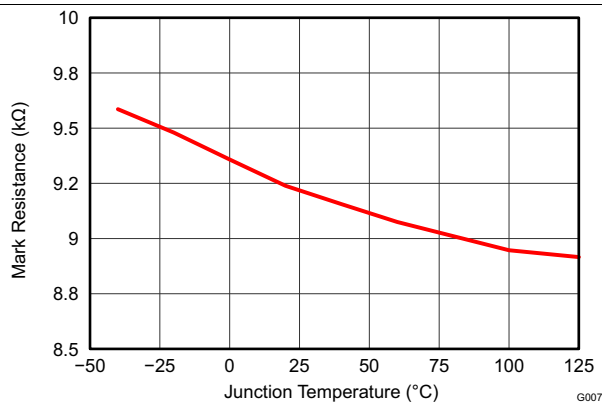

Figure 7. Mark Resistance vs Temperature

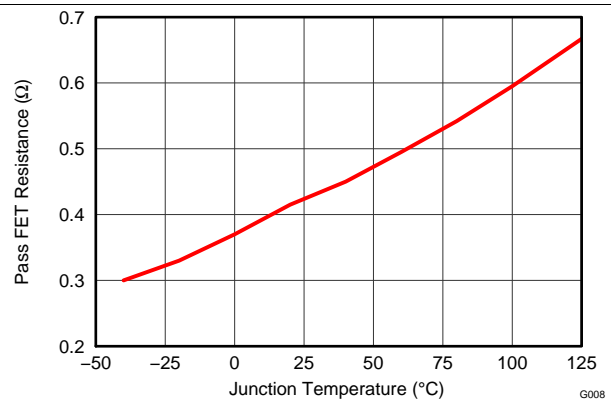

Figure 8. Pass FET Resistance vs Temperature

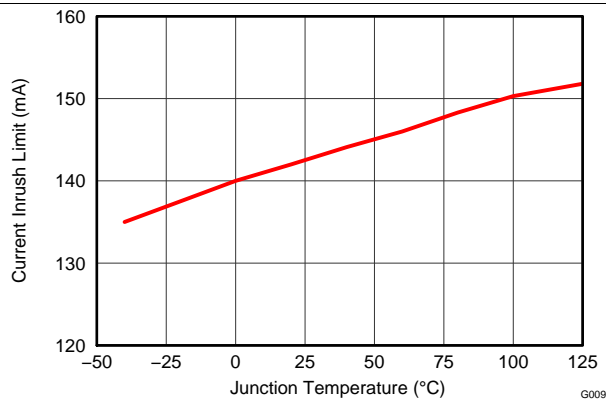

Figure 9. PoE Inrush Current Limit vs Temperature

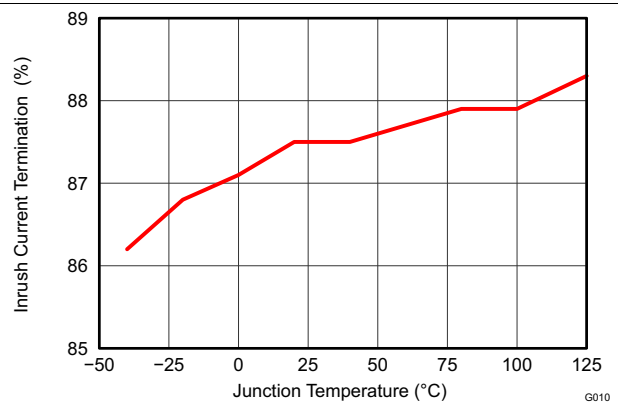

Figure 10. Inrush Termination Threshold vs Temperature

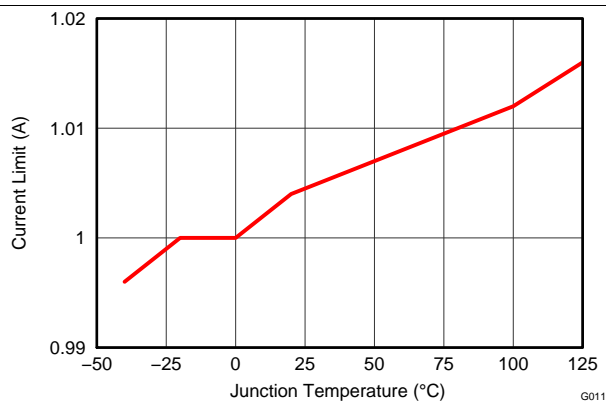

Figure 11. PoE Current Limit vs Temperature

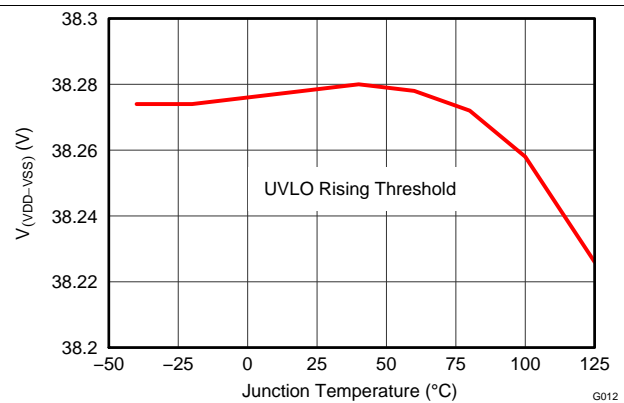
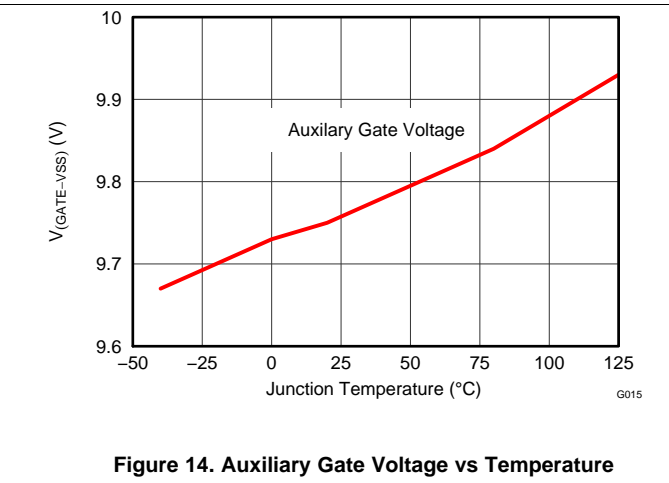
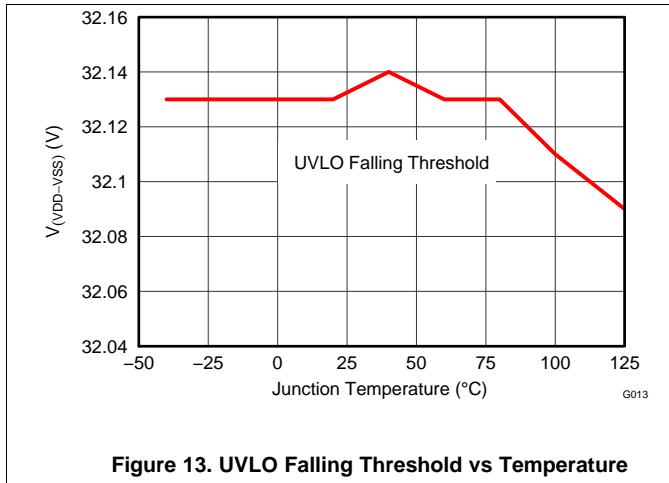
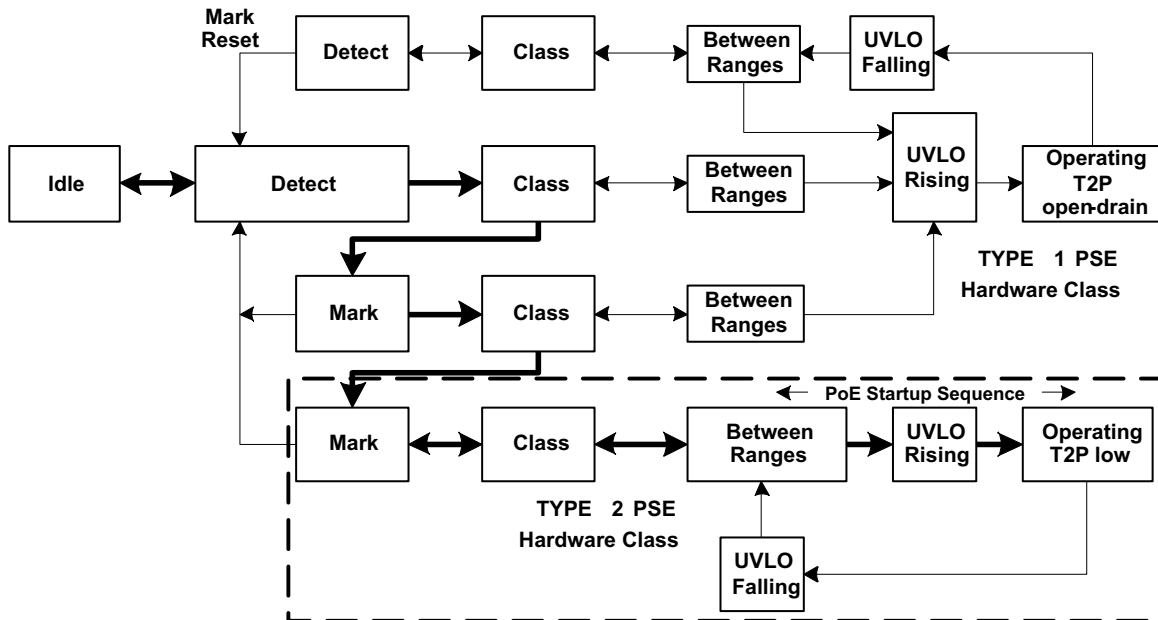

Figure 12. UVLO Rising Threshold vs Temperature

Typical Characteristics (continued)



7 Parameter Measurement Information



8 Detailed Description

8.1 Overview

The TPS2379 device is an 8-pin integrated circuit that contains all of the features needed to implement an IEEE802.3at type-2 powered device (PD) such as Detection, Classification, Type 2 Hardware Classification, and 140mA inrush current limit during start-up.

The TPS2379 integrates a low 0.5-Ω internal switch to allow for up to 0.85 A of continuous current through the PD during normal operation.

The TPS2379 supports higher power PoE applications through the use of an external pass transistor.

The TPS2379 contains several protection features such as thermal shutdown, current limit foldback, and a robust 100V internal switch.

8.2 Functional Block Diagram

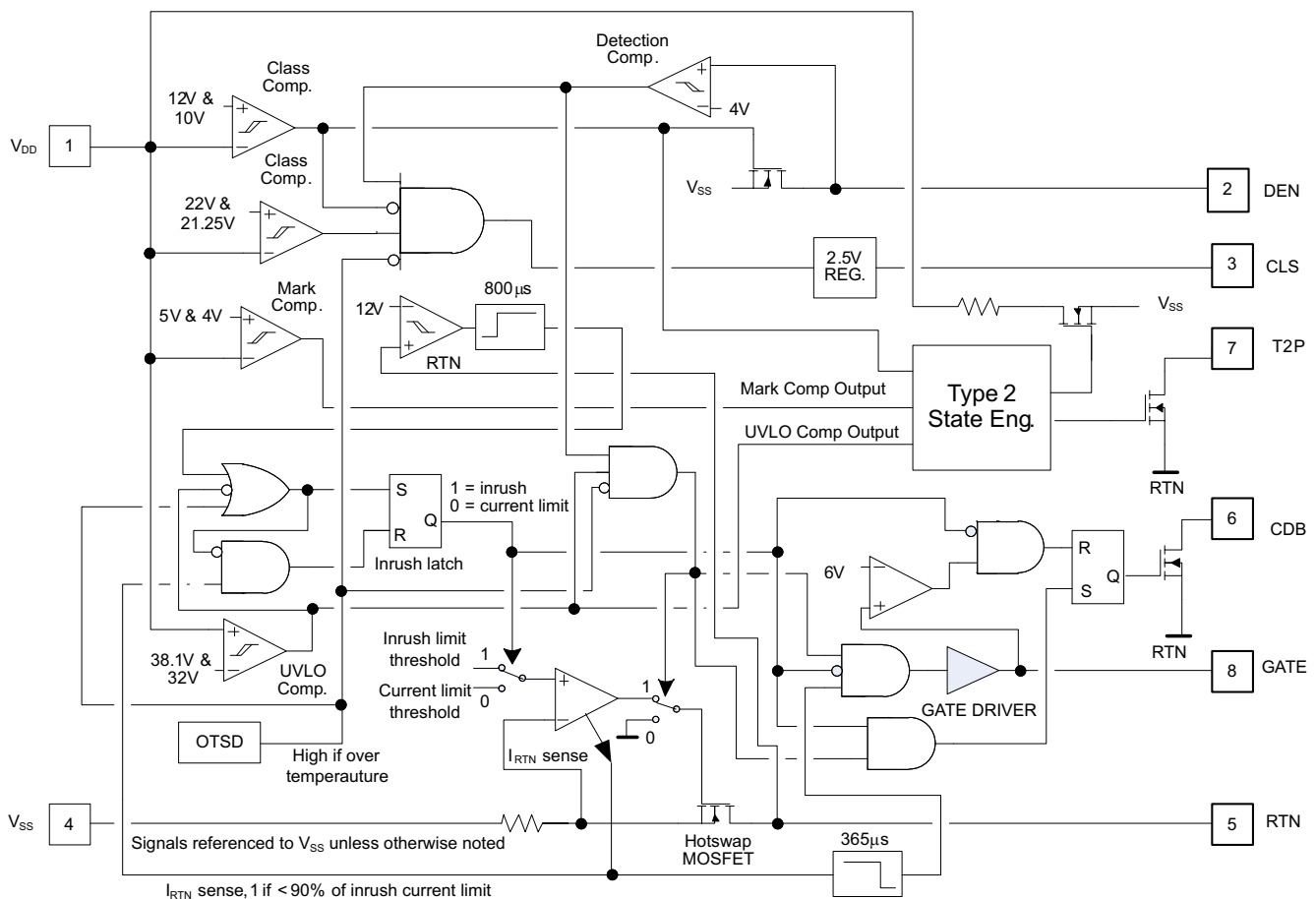

8.3 Feature Description

8.3.1 CDB Converter Disable Bar Pin Interface

CDB is an active low output that is pulled to RTN when the device is in inrush current limiting, going open when the inrush period has completed once the GATE output has become higher than 6 V. This ensures the external pass transistor is enhanced before the load is enabled. It remains in a high impedance state at all other times. This pin is an opendrain output and may require a pullup resistor or other interface to the downstream load. CDB may be left open if unused.

Feature Description (continued)

The CDB pin can inhibit downstream converter start up by keeping the soft start pin low. Figure 16 shows where the CDB connects to the SS pin of a UCC2897A DC-DC controller. Because CDB is an open drain output, it will not affect the soft start capacitor charge time when it deasserts. The CDB pin can also enable a converter with an active-high enable input. In this case, CDB may require a pullup resistor to either VDD, or to a bias supply, depending on the requirements of the controller enable pin.

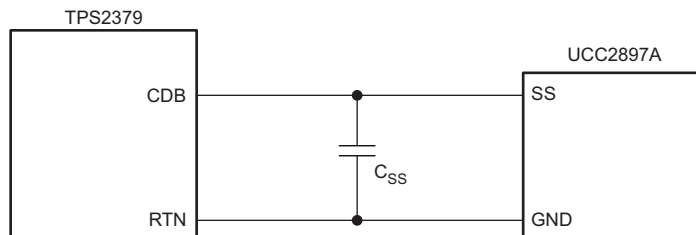

Figure 16. CDB Interface

8.3.2 CLS Classification

An external resistor (R_{CLS}) connected between the CLS pin and VSS provides a classification signature to the PSE. The controller places a voltage of approximately 2.5 V across the external resistor whenever the voltage differential between VDD and VSS is between about 10.9 V and 22 V. The current drawn by this resistor, combined with the internal current drain of the controller and any leakage through the internal pass MOSFET, creates the classification current. Table 1 lists the external resistor values required for each of the PD power ranges defined by IEEE802.3at. The maximum average power drawn by the PD combined with the power supplied to the downstream load should not exceed the maximum power indicated in Table 1.

Table 1. Class Resistor Selection

CLASS	MINIMUM POWER AT PD (W)	MAXIMUM POWER AT PD	RESISTOR R_{CLS} (Ω)
0	0.44	12.95	1270
1	0.44	3.84	243
2	3.84	6.49	137
3	6.49	12.95	90.9
4	12.95	25.5	63.4

8.3.3 DEN Detection and Enable

DEN pin implements two separate functions. A resistor (R_{DEN}) connected between V_{DD} and DEN generates a detection signature whenever the voltage differential between VDD and VSS is from 1.4 V and 10.9 V. Beyond this range, the controller disconnects this resistor to save power. The IEEE 802.3at standard specifies a detection signature resistance, R_{DEN} from 23.75 k Ω to 26.25 k Ω , or 25 k $\Omega \pm 5\%$. A resistor of 24.9 k $\Omega \pm 1\%$ is recommended for R_{DEN} .

If the resistance connected between V_{DD} and DEN is divided into two roughly equal portions, then the application circuit can disable the PD by grounding the tap point between the two resistances. This action simultaneously spoils the detection signature and thereby signals the PSE that the PD no longer requires power.

8.3.4 GATE Auxiliary Gate Driver

GATE pin allows the connection of an external pass MOSFET in parallel with the internal pass transistor. The GATE pin enables the external transistor after inrush has completed. The current is divided between the external MOSFET and the internal transistor as a function of their respective resistances. The addition of a balancing resistor (R_{BLST}) in series with RTN and the external MOSFET can ensure the desired distribution of the two currents. When the RTN current exceeds the current limit threshold, the GATE pin will pull low after a 365 μ s delay. The GATE pin is pulled low in thermal shutdown. After the controller cools down and the inrush cycle is complete, the GATE pin rises again.

A nonstandard PoE system can be designed to meet extended power requirements and retain the PoE benefits, such as protection of non-PoE devices and fault tolerance. This type of solution will not comply with IEEE802.3at and should be designed and operated as stand-alone system. The TPS2379 GATE pin controls an external pass MOSFET as shown in Figure 17. When the inrush is complete, GATE sources 38 μ A to enable Q1, the external pass MOSFET. When Q1 is fully enhanced, CDB deasserts and enables the load. Delaying the deassertion of CDB until Q1 becomes fully enhanced prevents nuisance overcurrent faults that could occur with heavy start-up loads. A resistor from GATE to VSS is not required to ensure that Q1 turns off. If a resistor from GATE to VSS is used, choose a value large enough so that the GATE sourcing current can fully enhance Q1.

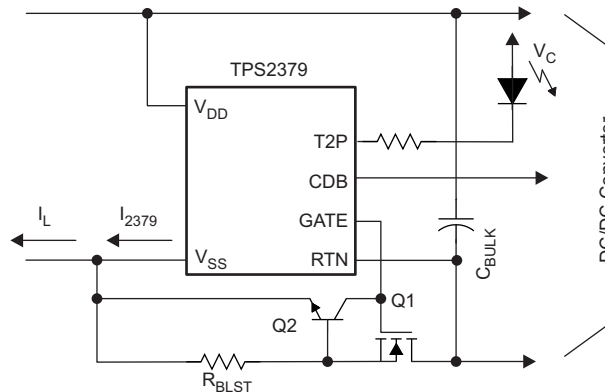

Figure 17. GATE Interface

8.3.4.1 External Boost Circuit (Q1, Q2, and R_{BLST}) Considerations

The IEEE802.3at template bounds the peak PSE output current from 50 A for 10 μ s and 1.75 A for 75 ms for a two-pair system. In a nonstandard, four-pair system, these current levels may double. During an overload event, the TPS2379 device will limit current to approximately 1 A and the rest of the current will flow through Q1 and R_{BLST} . Ignoring the ballast resistor and parasitic impedances, the current through Q1 could be as high as 99 A.

Actual system level behavior will be influenced by the circuit parasitic impedances, diode bridge impedance, contact resistances, external MOSFET resistance, and input voltage droop during the overload event. The impedances act to reduce the peak current as well as drop the voltage across Q1 during the overload event. Evaluate the overload performance of your system and ensure that the selected external MOSFET safe operating area (SOA) is not violated during the output overload. The duration of the overload can be terminated if the input voltage droop to the TPS2379 goes below the UVLO falling threshold (typically 32 V). When UVLO occurs, the internal MOSFET is disabled, GATE goes low and the external MOSFET is disabled. This shortened overload duration is beneficial when evaluating the external MOSFET SOA performance.

Additional limiting and control of the external output overload current can be achieved by using the ballast resistor, R_{BLST} . R_{BLST} helps balance the internal and external MOSFET load currents and implements external current limiting through Q2. The load current, I_L , divides between the external Q1 and the internal pass MOSFET of the TPS2379 as shown Equation 1.

$$I_{2379} = I_L \times \frac{R_{BLST} + R_{Q1}}{R_{BLST} + R_{Q1} + R_{2379}} \quad (1)$$

R_{Q1} is the ON resistance of Q1 and R_{2379} is the ON resistance of the TPS2379. Q2 can be used to force Q1 to limit its current when the voltage across R_{BLST} exceeds V_{BEON} of Q2. For further discussion of these details and additional considerations involving PD classification, see the application report titled *Implementing a 60-W End-to-End PoE System (SLVA498)*.

8.3.5 Internal Pass MOSFET

RTN pin provides the negative power return path for the load. When V_{DD} exceeds the UVLO threshold, the internal pass MOSFET pulls RTN to VSS. Inrush limiting prevents the RTN current from exceeding 140 mA until the bulk capacitance (C_{BULK} in Figure 26) is fully charged. Inrush ends when the RTN current drops below about 125 mA. The RTN current is subsequently limited to about 1 A. CDB pulls low to signal the downstream load that the bulk capacitance is fully charged. If RTN ever exceeds about 12 V for longer than 800 μ s, the TPS2379 returns to inrush limiting.

8.3.6 T2P Type-2 PSE Indicator

The TPS2379 pulls T2P to RTN when type-2 hardware classification has been observed. The T2P output will return to a high-impedance state if the part enters thermal shutdown, the pass MOSFET enters inrush limiting, or if a type-2 PSE was not detected. The circuitry that watches for type-2 hardware classification latches its result when the V_{DD} -to- V_{SS} voltage differential rises above the upper classification threshold. This circuit resets when the V_{DD} -to- V_{SS} voltage differential drops below the mark threshold. The T2P pin can be left unconnected if unused.

The T2P pin is an active-low, opendrain output which indicates that a high power source is available. An optocoupler can interface the T2P pin to circuitry on the secondary side of the converter. A high-gain optocoupler and a high-impedance (that is, CMOS) receiver are recommended. Figure 18 presents the design of the T2P optocoupler interface.

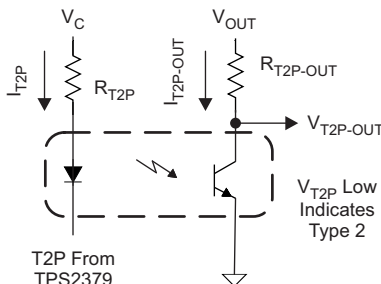

Figure 18. T2P Interface

To design the T2P octocoupler interface, do the following:

1. Let $V_C = 12\text{ V}$, $V_{OUT} = 5\text{ V}$, $R_{T2P-OUT} = 10\text{ k}\Omega$, $V_{T2P} = 260\text{ mV}$, $V_{T2P-OUT} = 400\text{ mV}$.

$$I_{T2P-OUT} = \frac{V_{OUT} - V_{T2P-OUT}}{R_{T2P-OUT}} = \frac{5 - 0.4}{10000} = 0.46\text{mA} \tag{2}$$

2. The optocoupler current transfer ratio, CTR, will be needed to determine R_{T2P} . A device with a minimum CTR of 100% at 1 mA LED bias current, I_{T2P} , is selected. CTR will vary with temperature, LED bias current, and aging. These variations may require some iteration using the CTR-versus- I_{DIODE} curve on the optocoupler data sheet.

- (a) The approximate forward voltage of the optocoupler diode, V_{FWLED} , is 1.1 V from the data sheet.
- (b) Select a 10.7-k Ω resistor.

$$I_{T2P-MIN} = \frac{I_{T2P-OUT}}{CTR} = \frac{0.46\text{mA}}{1.00} = 0.46\text{mA}, \text{ Select } I_{T2P} = 1\text{mA}$$

$$R_{T2P} = \frac{V_C - V_{T2P} - V_{FWLED}}{I_{T2P}} = \frac{12\text{ V} - 0.26\text{ V} - 1.1\text{ V}}{1\text{mA}} = 10.6\text{k}\Omega \tag{3}$$

- (c) Select a 10.7-k Ω resistor.

8.3.7 VDD Supply Voltage

VDD pin connects to the positive side of the input supply. It provides operating power to the PD controller and allows monitoring of the input line voltage.

8.3.8 VSS

VSS pin is the input supply negative rail that serves as a local ground. The PowerPAD must be connected to this pin to ensure proper operation.

8.3.9 PowerPAD

The PowerPAD is internally connected to V_{SS} . The PowerPAD should be tied to a large V_{SS} copper area on the PCB to provide a low resistance thermal path to the circuit board. TI recommends that a clearance of 0.025" be maintained between V_{SS} and high-voltage signals such as V_{DD} .

8.4 Device Functional Modes

8.4.1 PoE Overview

The following text is intended as an aid in understanding the operation of the TPS2379 but not as a substitute for the IEEE 802.3at standard. The IEEE 802.3at standard is an update to IEEE 802.3-2008 clause 33 (PoE), adding high-power options and enhanced classification. Generally speaking, a device compliant to IEEE 802.3-2008 is referred to as a type 1 device, and devices with high power and enhanced classification will be referred to as type 2 devices. Standards change and should always be referenced when making design decisions.

The IEEE 802.3at standard defines a method of safely powering a PD (powered device) over a cable by power sourcing equipment (PSE), and then removing power if a PD is disconnected. The process proceeds through an idle state and three operational states of detection, classification, and operation. The PSE leaves the cable unpowered (idle state) while it periodically looks to see if something has been plugged in; this is referred to as detection. The low power levels used during detection are unlikely to damage devices not designed for PoE. If a valid PD signature is present, the PSE may inquire how much power the PD requires; this is referred to as classification. The PSE may then power the PD if it has adequate capacity.

Type 2 PSEs are required to do type 1 hardware classification plus a (new) data-layer classification, or an enhanced type 2 hardware classification. Type 1 PSEs are not required to do hardware or data link layer (DLL) classification. A type 2 PD must do type 2 hardware classification as well as DLL classification. The PD may return the default, 13W current-encoded class, or one of four other choices. DLL classification occurs after power-on and the Ethernet data link has been established.

When started, the PD must present a maintain power signature (MPS) to assure the PSE that it is still present. The PSE monitors its output for a valid MPS, and turns the port off if it loses the MPS. Loss of the MPS returns the PSE to the idle state. [Figure 19](#) shows the operational states as a function of PD input voltage. The upper half is for IEEE 802.3-2008, and the lower half shows specific differences for IEEE 802.3at. The dashed lines in the lower half indicate these are the same (that is, Detect and Class) for both.

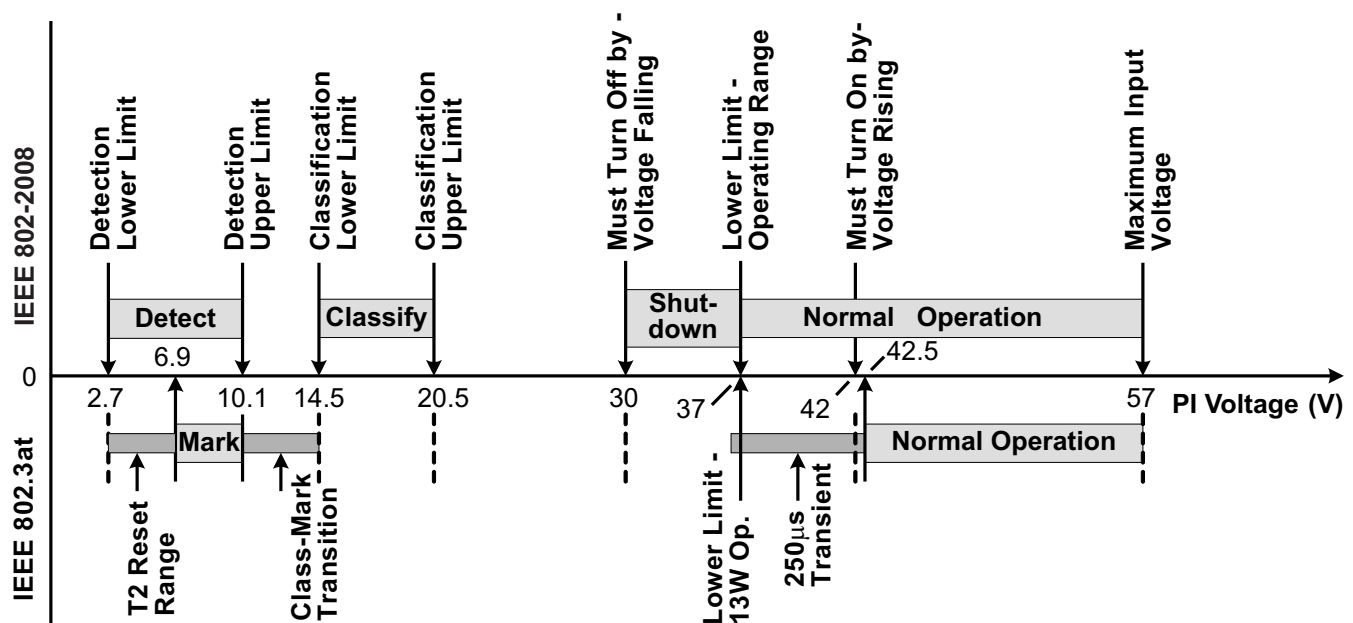

Figure 19. Threshold Voltages

The PD input, typically an RJ-45 eight-lead connector, is referred to as the power interface (PI). PD input requirements differ from PSE output requirements to account for voltage drops and operating margin. The standard allots the maximum loss to the cable regardless of the actual installation to simplify implementation. IEEE 802.3-2008 was designed to run over infrastructure including ISO/IEC 11801 class C (CAT3 per TIA/EIA-568) that may have had AWG 26 conductors. IEEE 802.3at type 2 cabling power loss allotments and voltage drops have been adjusted for 12.5 Ω power loops per ISO/IEC 11801 class D (CAT5 or higher per TIA/EIA-568, typically AWG #24 conductors). [Table 2](#) shows key operational limits broken out for the two revisions of the standard.

Device Functional Modes (continued)

Table 2. Comparison of Operational Limits

STANDARD	POWER LOOP RESISTANCE (max)	PSE OUTPUT POWER (min)	PSE STATIC OUTPUT VOLTAGE (min)	PD INPUT POWER (max)	STATIC PD INPUT VOLTAGE	
					Power ≤12.95W	Power >12.95W
IEEE802.3at-2008 802.3at (Type 1)	20Ω	15.4W	44V	12.95W	37V – 57V	N/A
802.3at (Type 2)	12.5Ω	30W	50V	25.5W	37V – 57V	42.5V – 57V

The PSE can apply voltage either between the RX and TX pairs (pins 1 - 2 and 3 - 6 for 10baseT or 100baseT), or between the two spare pairs (4 - 5 and 7 - 8). Power application to the same pin combinations in 1000baseT systems is recognized in IEEE 802.3at. 1000baseT systems can handle data on all pairs, eliminating the spare pair terminology. The PSE may only apply voltage to one set of pairs at a time. The PD uses input diode bridges to accept power from any of the possible PSE configurations. The voltage drops associated with the input bridges create a difference between the standard limits at the PI and the TPS2379 specifications.

A compliant type 2 PD has power management requirements not present with a type 1 PD. These requirements include the following:

1. Must interpret type 2 hardware classification,
2. Must present hardware class 4,
3. Must implement DLL negotiation,
4. Must behave like a type 1 PD during inrush and start-up,
5. Must not draw more than 13W for 80ms after the PSE applies operating voltage (power up),
6. Must not draw more than 13W if it has not received a type 2 hardware classification or received permission through DLL,
7. Must meet various operating and transient templates, and
8. Optionally monitor for the presence or absence of an adapter (assume high power).

As a result of these requirements, the PD must be able to dynamically control its loading, and monitor T2P for changes. In cases where the design needs to know specifically if an adapter is plugged in and operational, the adapter should be individually monitored, typically with an optocoupler.

8.4.1.1 Threshold Voltages

The TPS2379 has a number of internal comparators with hysteresis for stable switching between the various states. Figure 20 relates the parameters in the Electrical Characteristics section to the PoE states. The mode labeled Idle between Classification and Operation implies that the DEN, CLS, and RTN pins are all high impedance. The state labeled Mark, which is drawn in dashed lines, is part of the new type 2 hardware class state machine.

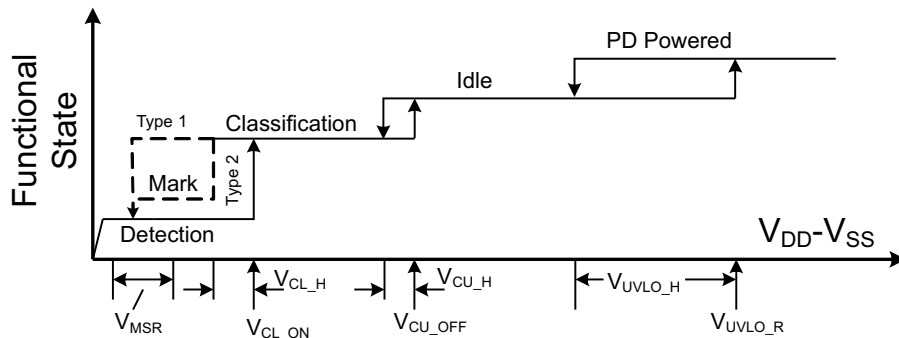

Note: Variable names refer to Electrical Characteristic Table parameters

Figure 20. Threshold Voltages

8.4.1.2 PoE Start-Up Sequence

The waveforms of [Figure 21](#) demonstrate detection, classification, and start-up from a PSE with type 2 hardware classification. The key waveforms shown are $V(V_{DD-VSS})$, $V(RTN-VSS)$, and IPI. IEEE 802.3at requires a minimum of two detection levels, two class and mark cycles, and start-up from the second mark event. V_{RTN} to V_{SS} falls as the TPS2379 charges C_{BULK} following application of full voltage. In [Figure 21](#), deassertion of the CDB signal is delayed and used to enable load current as seen in the I_{PI} waveform.

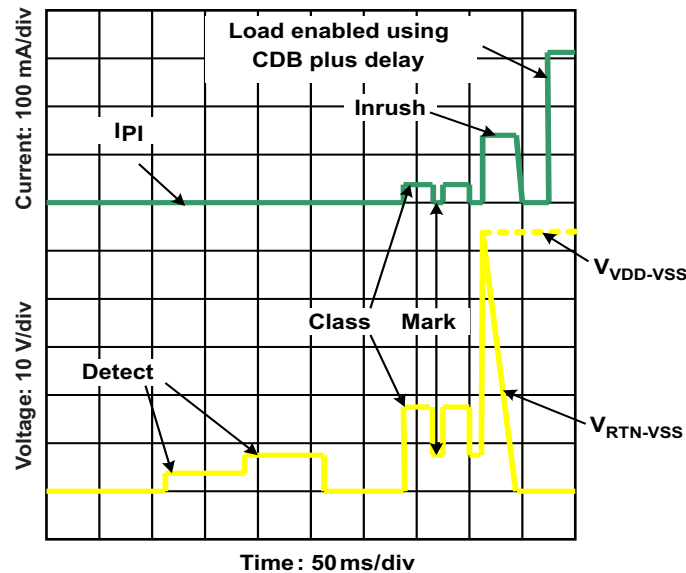

Figure 21. Start-up

8.4.1.3 Detection

The TPS2379 pulls DEN to V_{SS} whenever $V_{(V_{DD-VSS})}$ is below the lower classification threshold. When the input voltage rises above V_{CL-ON} , the DEN pin goes to an opendrain condition to conserve power. While in detection, RTN is high impedance, and almost all the internal circuits are disabled. An R_{DEN} of $24.9\text{ k}\Omega$ ($\pm 1\%$), presents the correct signature. It may be a small, low-power resistor because it only sees a stress of about 5 mW. A valid PD detection signature is an incremental resistance ($\Delta V/\Delta I$) between $23.75\text{ k}\Omega$ and $26.25\text{ k}\Omega$ at the PI.

The detection resistance seen by the PSE at the PI is the result of the input bridge resistance in series with the parallel combination of R_{DEN} and internal VDD loading. The input diode bridge's incremental resistance may be hundreds of ohms at the very low currents drawn when 2.7 V is applied to the PI. The input bridge resistance is partially compensated by the TPS2379's effective resistance during detection.

The type 2 hardware classification protocol of IEEE 802.3at specifies that a type 2 PSE drops its output voltage into the detection range during the classification sequence. The PD is required to have an incorrect detection signature in this condition, which is referred to as a mark event (see [Figure 21](#)). After the first mark event, the TPS2379 will present a signature less than $12\text{ k}\Omega$ until it has experienced a $V_{(V_{DD-VSS})}$ voltage below the mark reset threshold (V_{MSR}). This is explained more fully under Hardware Classification.

8.4.1.4 Hardware Classification

Hardware classification allows a PSE to determine a PD's power requirements before powering, and helps with power management once power is applied. Type 2 hardware classification permits high power PSEs and PDs to determine whether the connected device can support high-power operation. A type 2 PD presents class 4 in hardware to indicate that it is a high-power device. A type 1 PSE will treat a class 4 device like a class 0 device, allotting 13 W if it chooses to power the PD. A PD that receives a 2-event class understands that it is powered from a high-power PSE and it may draw up to 25.5 W immediately after the 80 ms start-up period completes. A type 2 PD that does not receive a 2-event hardware classification may choose to not start, or must start in a 13 W condition and request more power through the DLL after start-up. The standard requires a type 2 PD to indicate that it is underpowered if this occurs. Start-up of a high-power PD under 13 W implicitly requires some form of powering down sections of the application circuits.

The maximum power entries in Table 1 determine the class the PD must advertise. The PSE may disconnect a PD if it draws more than its stated Class power, which may be the hardware class or a lower DLL-derived power level. The standard permits the PD to draw limited current peaks that increase the instantaneous power above the Table 1 limit, however the average power requirement always applies.

The TPS2379 implements two-event classification. Selecting an RCLS of 63.4 Ω provides a valid type 2 signature. TPS2379 may be used as a compatible type 1 device simply by programming class 0–3 per Table 1. DLL communication is implemented by the Ethernet communication system in the PD and is not implemented by the TPS2379.

The TPS2379 disables classification above V_{CU_OFF} to avoid excessive power dissipation. CLS voltage is turned off during PD thermal limiting or when DEN is active. The CLS output is inherently current-limited, but should not be shorted to V_{SS} for long periods of time.

Figure 22 shows how classification works for the TPS2379. Transition from state-to-state occurs when comparator thresholds are crossed (see Figure 19 and Figure 20). These comparators have hysteresis, which adds inherent memory to the machine. Operation begins at idle (unpowered by PSE) and proceeds with increasing voltage from left to right. A 2-event classification follows the (heavy lined) path towards the bottom, ending up with a latched type 2 decode along the lower branch that is highlighted. This state results in a low T2P during normal operation. Once the valid path to type 2 PSE detection is broken, the input voltage must transition below the mark reset threshold to start anew.

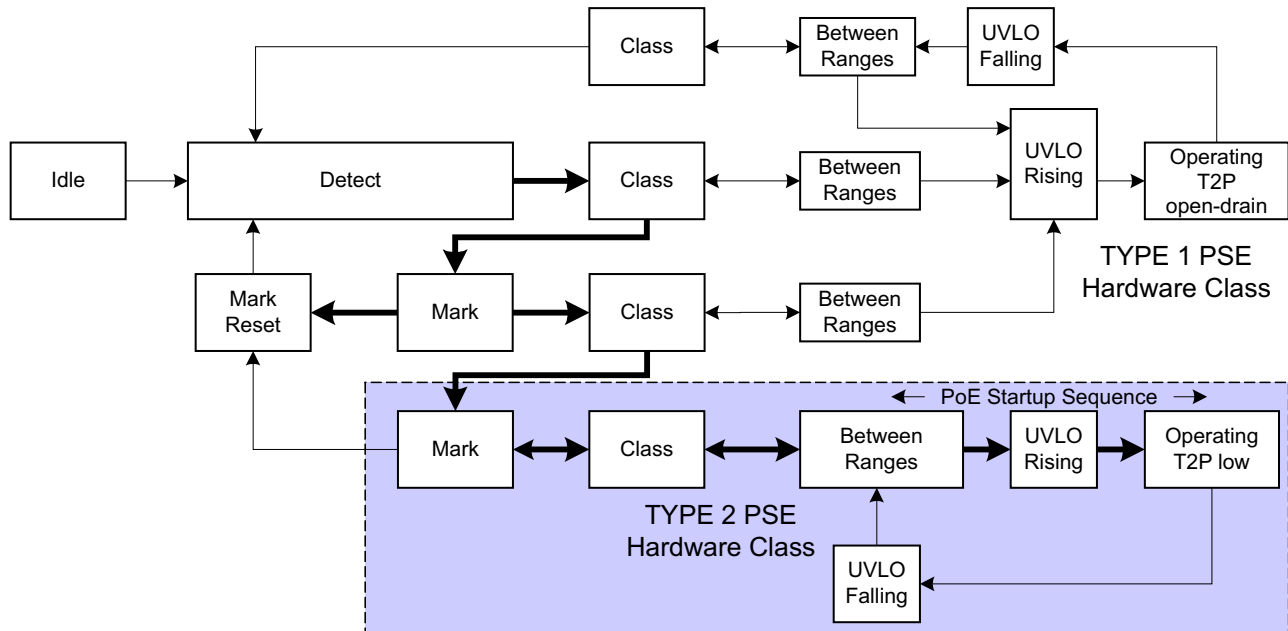

Figure 22. Two-Event Class Internal States

8.4.1.5 Inrush and Start-up

IEEE 802.3at has a start-up current and time limitation, providing type 2 PSE compatibility for type 1 PDs. A type 2 PSE limits output current to between 400 mA and 450 mA for up to 75 ms after power up (applying “48 V” to the PI) to mirror type 1 PSE functionality. The type 2 PSE will support higher output current after 75 ms. The TPS2379 implements a 140 mA inrush current, which is compatible with all PSE types. A high-power PD must limit its converter start-up peak current. The operational current cannot exceed 400 mA for a period of 80 ms or longer. This requirement implicitly requires some form of powering down sections of the application circuits.

8.4.1.6 Maintain Power Signature

The MPS is an electrical signature presented by the PD to assure the PSE that it is still present after operating voltage is applied. A valid MPS consists of a minimum DC current of 10 mA (or a 10 mA pulsed current for at least 75 ms every 325 ms) and an AC impedance lower than 26.3 k Ω in parallel with 0.05 μ F. The AC impedance is usually accomplished by the minimum operating C_{BULK} requirement of 5 μ F. When DEN is used to force the hotswap switch off, the DC MPS will not be met. A PSE that monitors the DC MPS will remove power from the PD when this occurs. A PSE that monitors only the ac MPS may remove power from the PD.

8.4.1.7 Start-up and Operation

The internal PoE UVLO (Under Voltage Lock Out) circuit holds the hotswap switch off before the PSE provides full voltage to the PD. This prevents the downstream converter circuits from loading the PoE input during detection and classification. The converter circuits will discharge C_{BULK} while the PD is unpowered. Thus $V_{(VDD-RTN)}$ will be a small voltage just after full voltage is applied to the PD, as seen in Figure 21. The PSE drives the PI voltage to the operating range once it has decided to power up the PD. When V_{VDD} rises above the UVLO turnon threshold (V_{UVLO-R} , approximately 38 V) with RTN high, the TPS2379 enables the hotswap MOSFET with an approximate 140 mA (inrush) current limit as seen in Figure 23. The CDB pin is active while C_{BULK} charges and V_{RTN} falls from V_{VDD} to nearly V_{VSS} . Once the inrush current falls about 10% below the inrush current limit, the PD current limit switches to the operational level (approximately 1000 mA) and CDB is deasserted to allow downstream converter circuitry to start. The TPS2379 asserts GATE after inrush is complete to enable an external pass MOSFET if used. In Figure 23, T2P is active because a type 2 PSE is plugged in.

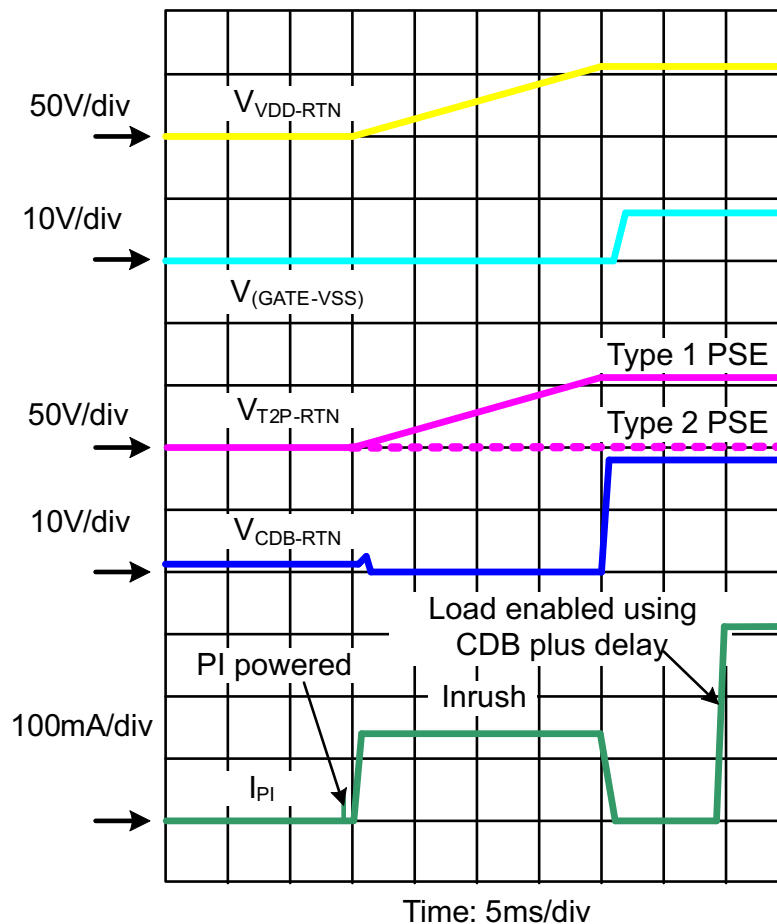

Figure 23. Power Up and Start

8.4.1.8 PD Hotswap Operation

IEEE 802.3at has taken a new approach to PSE output limiting. A type 2 PSE must meet an output current versus time template with specified minimum and maximum sourcing boundaries. The peak output current may be as high as 50 A for 10 μ s or 1.75 A for 75 ms. This makes robust protection of the PD device even more important than it was in IEEE 802.3-2008.

The internal hotswap MOSFET is protected against output faults and input voltage steps with a current limit and deglitched (time-delay filtered) foldback. An overload on the pass MOSFET engages the current limit, with V_{RTN} - V_{VSS} rising as a result. GATE is pulled down about 300 μ s after RTN current reaches the current limit level. If V_{RTN} rises above approximately 12 V for longer than about 800 μ s, the current limit reverts to the inrush value. The 800 μ s deglitch feature prevents momentary transients from causing a PD reset, provided that recovery lies within the bounds of the hotswap and PSE protection. Figure 24 shows an example of the RTN current profile during VDD to RTN short circuit when only the internal hotswap MOSFET is used. The hotswap MOSFET goes into current limit, causing the RTN voltage to increase. Once V_{RTN} exceeds 12V, I_{RTN} which was clamped to the current limit drops to the level of inrush current limit after 800 μ s.

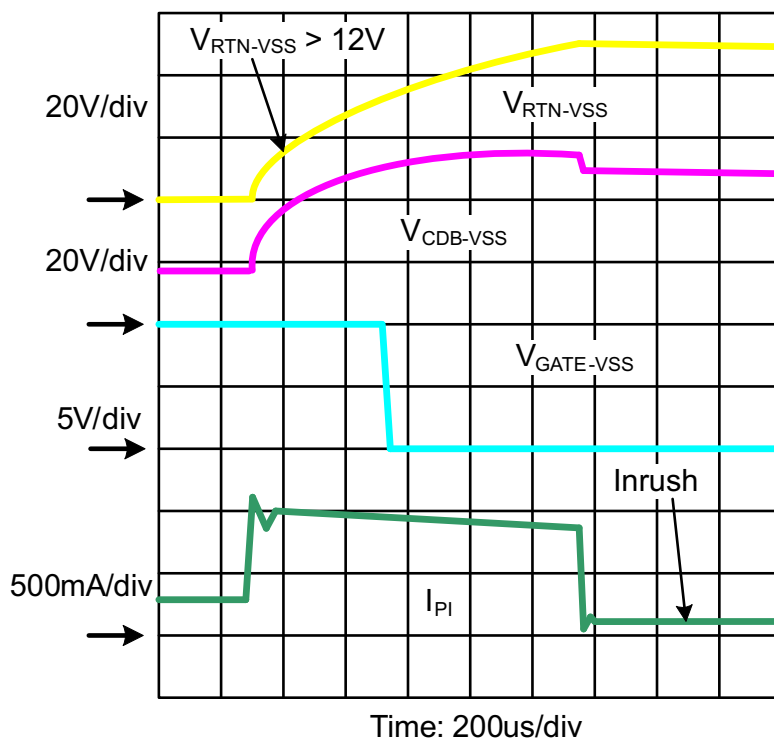

Figure 24. Response to PD Output Short Circuit Without AUX MOSFET

Figure 25 shows an example of the RTN current profile during VDD to RTN short circuit when the external MOSFET is used. The circuit is depicted in Figure 26. The current will divide between the internal and external MOSFETs. During the short circuit, the hotswap MOSFET goes into current limit, causing the RTN voltage to increase. When the internal MOSFET exceeds current limit for about 300 μ s, GATE will deassert and shut off the auxiliary MOSFET. V_{RTN} will rise quickly and the internal MOSFET will go into current limit for approximately 800 μ s (after V_{RTN} > about 12 V) and then I_{RTN} which was clamped to the current limit drops into the inrush current limit.

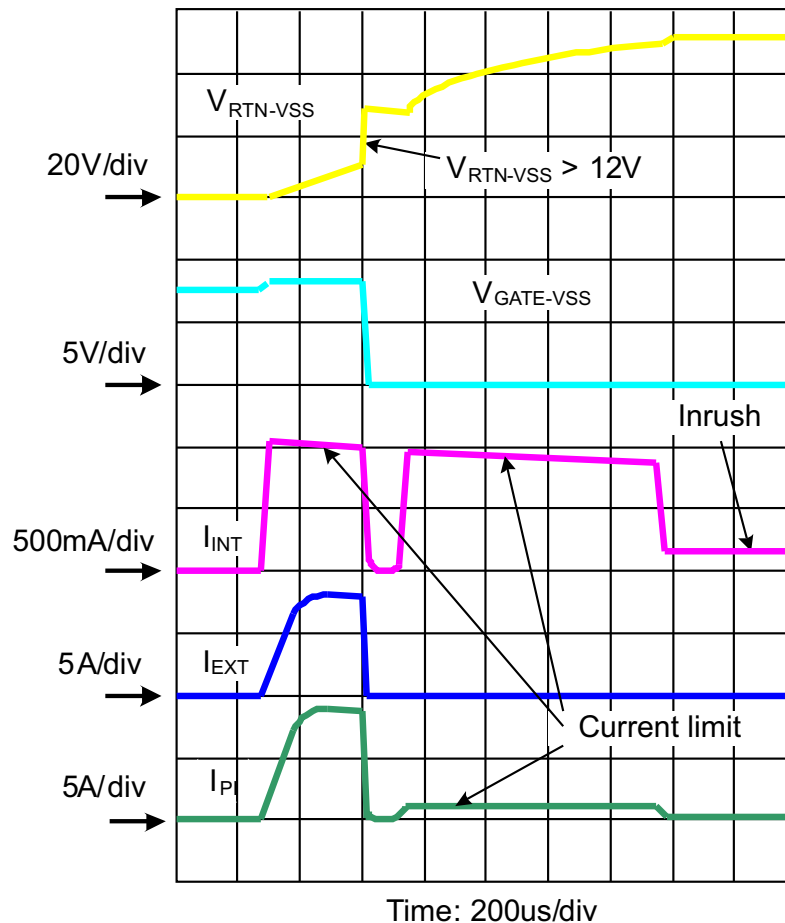

Figure 25. Response to PD Output Short Circuit With AUX MOSFET

The PD control has a thermal sensor that protects the internal hotswap MOSFET. Conditions like start-up or operation into a V_{DD} -to-RTN short cause high power dissipation in the MOSFET. An over-temperature shutdown (OTSD) turns off the hotswap MOSFET and class regulator, which are restarted after the device cools. The hotswap MOSFET will be re-enabled with the inrush current limit when exiting from an over-temperature event. Pulling DEN to V_{SS} during powered operation causes the internal hotswap MOSFET to turn off.

The hotswap switch will be forced off under the following conditions:

1. $V_{(DEN - VSS)} < V_{PD_DIS}$ when $V_{VDD} - V_{VSS}$ is in the operational range,
2. PD is over-temperature, or
3. $V_{(DEN - VSS)}$ PoE UVLO falling threshold (about 32 V).

8.4.1.9 CDB and T2P

CDB (converter disable) is an active-low pin that indicates when the internal hotswap MOSFET is inrush limiting. CDB deasserts when inrush is over and can be used to enable a downstream converter to start up. Common interfaces to the converter controller include the soft start or enable pins.

T2P (type 2 PSE) is an active-low multifunction pin that indicates if (PSE = Type_2) and (PD current limit \neq Inrush).

The usage of T2P is demonstrated in [Figure 18](#). When PSE applies and PD observes a type 2 hardware classification, T2P pin is pulled to RTN as a indication of the type of PSE.

8.4.1.10 Auxiliary Pass MOSFET Control

The TPS2379 can be used in non-standard applications requiring power significantly above the IEEE802.3at, type 2 levels. This implementation can be achieved by utilizing all four Ethernet wire pairs and boosting the TPS2379 hotswap MOSFET operating current limit. Boosting the TPS2379 operating current limit is achieved by adding an external pass MOSFET to share the total load current with the internal hotswap MOSFET. The external pass MOSFET is enabled by the GATE pin after the internal hotswap MOSFET inrush is complete. The GATE pin will deassert if the TPS2379 internal current limit is exceeded in excess of 300 μ s.

A comprehensive high power POE design example is discussed in application report *Implementing a 60-W, End-to-End PoE System* ([SLVA498](#)).

8.4.1.11 Using DEN to Disable PoE

The DEN pin may be used to turn the PoE hotswap switch off by pulling it to VSS while in the operational state, or to prevent detection when in the idle state. A low voltage on DEN forces the hotswap MOSFET off during normal operation.

9 Application and Implementation

NOTE

Information in the following applications sections is not part of the TI component specification, and TI does not warrant its accuracy or completeness. TI's customers are responsible for determining suitability of components for their purposes. Customers should validate and test their design implementation to confirm system functionality.

9.1 Application Information

The TPS2379 has the flexibility to be implemented in IEEE802.3at PDs, Universal Power Over Ethernet (UPOE) PDs, or high power non-standard PDs. Therefore, it can be used in a wide range applications such as video and VoIP telephones, multiband access points, security cameras, and pico-base stations.

9.2 Typical Application

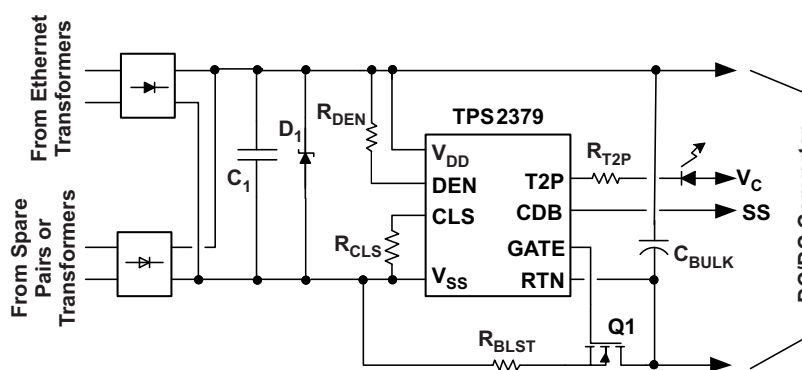

Figure 26. Typical Application Circuit

9.2.1 Design Requirements

Table 3. TPS2379EVM Electrical and Performance Specifications

PARAMETER	TEST CONDITIONS	MIN	TYP	MAX	UNIT
POWER INTERFACE					
Input voltage	Applied to the power pins of connectors J1 or J3	0		57	V
Operating voltage	After start-up	30		57	V
Input UVLO	Rising input voltage at device terminals			40	V
	Falling input voltage	30.5			
Detection voltage	At device terminals	1.4		10.1	V
Classification voltage	At device terminals	11.9		23	V
Detection signature			24.9		kΩ
Classification current	Class 4	38		42	mA
Inrush current limit		100		180	mA
Operating current limit	Internal plus external		2260		mA

9.2.2 Detailed Design Procedures

Given in Equation 5, R_{BLST} can be calculated using Equation 4

$$R_{BLST} = \frac{I_{2379}}{I_L - I_{2379}} R_{2379} - R_{Q1} = \frac{1A}{2.26A - 1A} 0.42\Omega - 0.064\Omega = 0.27\Omega \quad (4)$$

FM493TC can be used for Q2.

9.2.2.1 Input Bridges and Schottky Diodes

Using Schottky diodes instead of PN junction diodes for the PoE input bridges will reduce the power dissipation in these devices by about 30%. There are, however, some things to consider when using them.

The IEEE standard specifies a maximum backfeed voltage of 2.8 V. A 100 kΩ resistor is placed between the unpowered pairs and the voltage is measured across the resistor. Schottky diodes often have a higher reverse leakage current than PN diodes, making this a harder requirement to meet. To compensate, use conservative design for diode operating temperature, select lower-leakage devices where possible, and match leakage and temperatures by using packaged bridges.

Schottky diode leakage currents and lower dynamic resistances can impact the detection signature. Setting reasonable expectations for the temperature range over which the detection signature is accurate is the simplest solution. Increasing R_{DEN} slightly may also help meet the requirement.

Schottky diodes have proven less robust to the stresses of ESD transients than PN junction diodes. After exposure to ESD, Schottky diodes may become shorted or leak. Take care to provide adequate protection in line with the exposure levels. This protection may be as simple as ferrite beads and capacitors.

As a general recommendation, use 1 A or 2 A, 100 V rated discrete or bridge diodes for the input rectifiers.

9.2.2.2 Protection, D1

A TVS, D1, across the rectified PoE voltage per [Figure 26](#) must be used. A SMAJ58A, or equivalent, is recommended for general indoor applications. Adequate capacitive filtering or a TVS must limit input transient voltage to within the absolute maximum ratings. Outdoor transient levels or special applications require additional protection.

9.2.2.3 Capacitor, C₁

The IEEE 802.3at standard specifies an input bypass capacitor (from VDD to VSS) of 0.05 μF to 0.12 μF. Typically a 0.1 μF, 100 V, 10% ceramic capacitor is used.

9.2.2.4 Detection Resistor, R_{DEN}

The IEEE 802.3at standard specifies a detection signature resistance, R_{DEN} between 23.75 kΩ and 26.25 kΩ, or 25 kΩ ± 5%. A resistor of 24.9 kΩ ± 1% is recommended for R_{DEN}.

9.2.2.5 Classification Resistor, RCLS

Select RCLS according to [Table 1](#). For Class 4, choose RCLS = 63.4 Ω.

9.2.2.6 External Boost Circuit

For a PD application requiring current limit of 2.26 A at the PD input (approximately 96 W) and using Q1 FET BUK7275-100A

$$I_{2379} = I_L \times \frac{R_{BLST} + R_{Q1}}{R_{BLST} + R_{Q1} + R_{2379}} \quad (5)$$

9.2.3 Application Curves

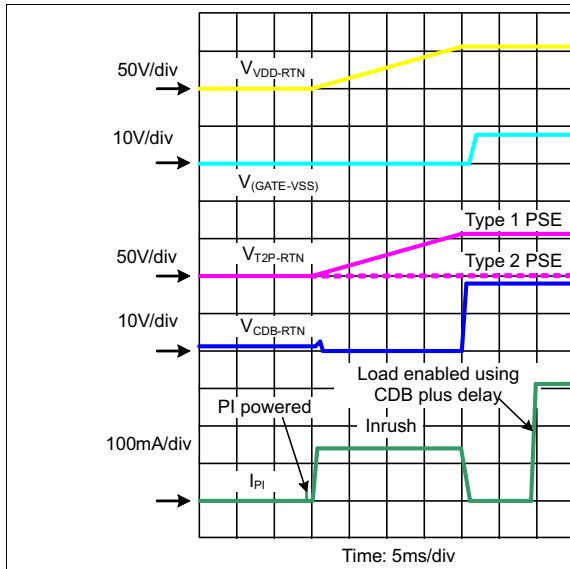

Figure 27. Power Up and Start

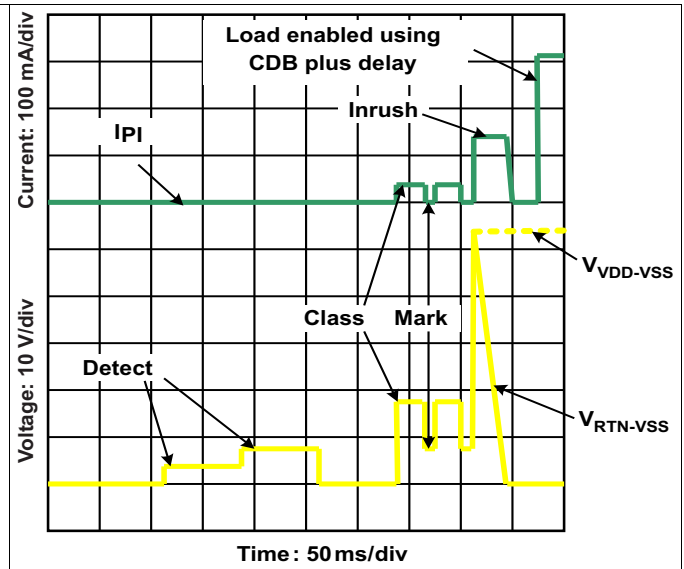

Figure 28. Start-up

10 Power Supply Recommendations

The TPS2379 will typically be followed by a power supply such as an isolated flyback or active clamp forward converter or a non-isolated buck converter. The input voltage of the converter should be capable of operating within the IEEE802.3at recommended input voltage as shown in [Table 2](#).

11 Layout

11.1 Layout Guidelines

The layout of the PoE front end should follow power and EMI/ESD best practice guidelines. A basic set of recommendations include:

- Parts placement must be driven by power flow in a point-to-point manner; RJ-45, Ethernet transformer, diode bridges, TVS and 0.1- μ F capacitor, and TPS2379.
- All leads should be as short as possible with wide power traces and paired signal and return.
- There should not be any crossovers of signals from one part of the flow to another.
- Spacing consistent with safety standards like IEC60950 must be observed between the 48-V input voltage rails and between the input and an isolated converter output.
- The TPS2379 should be located over split, local ground planes referenced to VSS for the PoE input and to RTN for the switched output.
- Large copper fills and traces should be used on SMT power-dissipating devices, and wide traces or overlay copper fills should be used in the power path.

11.1.1 EMI Containment

- Use compact loops for dv/dt and di/dt circuit paths (power loops and gate drives)
- Use minimal, yet thermally adequate, copper areas for heat sinking of components tied to switching nodes (minimize exposed radiating surface).
- Use copper ground planes (possible stitching) and top layer copper floods (surround circuitry with ground floods)
- Use 4 layer PCB if economically feasible (for better grounding)
- Minimize the amount of copper area associated with input traces (to minimize radiated pickup)
- Use Bob Smith terminations, Bob Smith EFT capacitor, and Bob Smith plane
- Use Bob Smith plane as ground shield on input side of PCB (creating a phantom or literal earth ground)
- Use of ferrite beads on input (allow for possible use of beads or 0 ohm resistors)
- Maintain physical separation between input-related circuitry and power circuitry (use ferrite beads as boundary line)
- Possible use of common-mode inductors
- Possible use of integrated RJ-45 jacks (shielded with internal transformer and Bob Smith terminations)
- End-product enclosure considerations (shielding)

11.2 Layout Example

Figure 29 and Figure 30 show the top and bottom layer and assemblies of the TPS2378EVM-106 as a reference for optimum parts placement. A detailed PCB layout can be found in the user's guide of the TPS2378EVM-106.

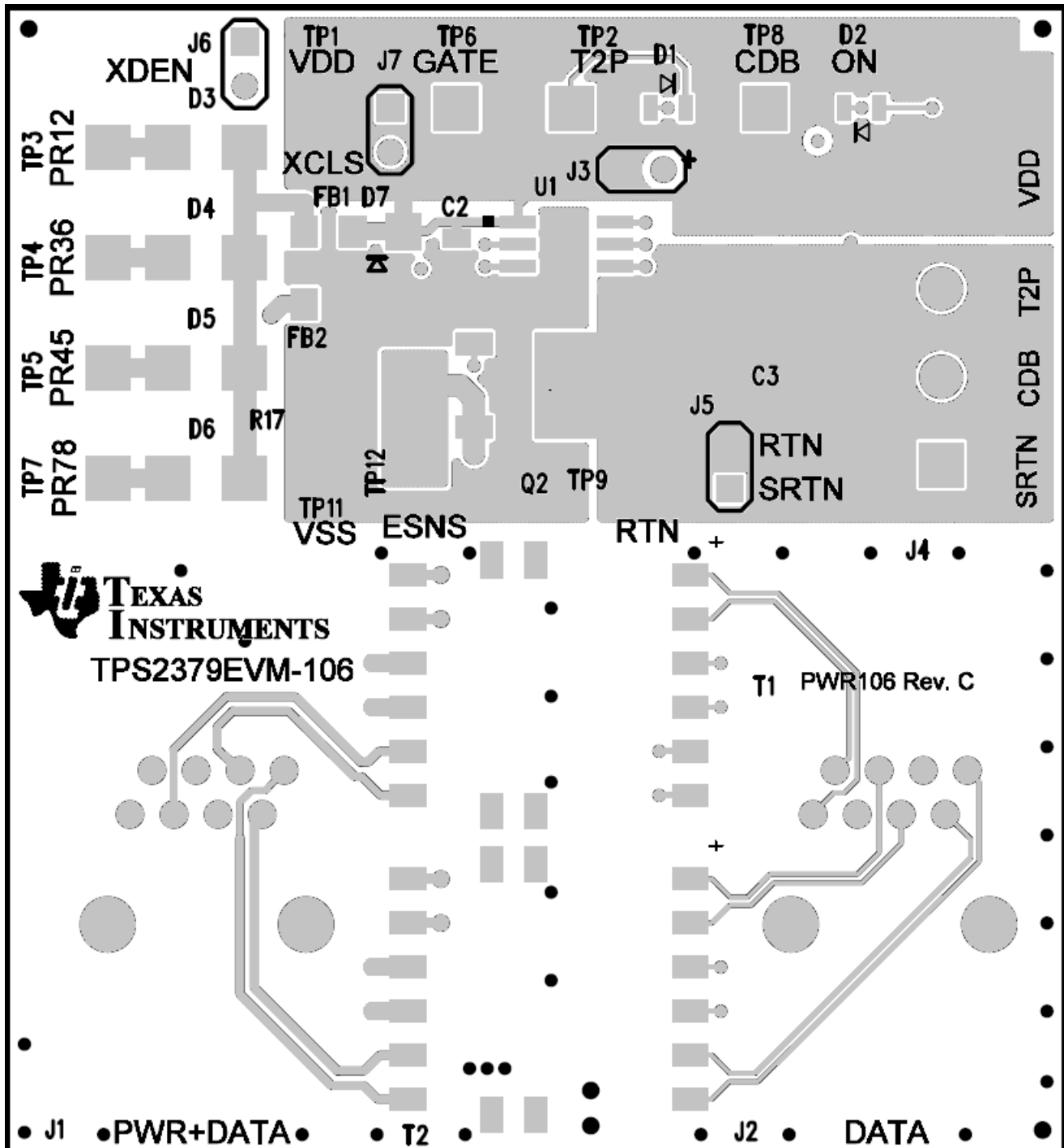

Figure 29. Recommended Layout Top View

Layout Example (continued)

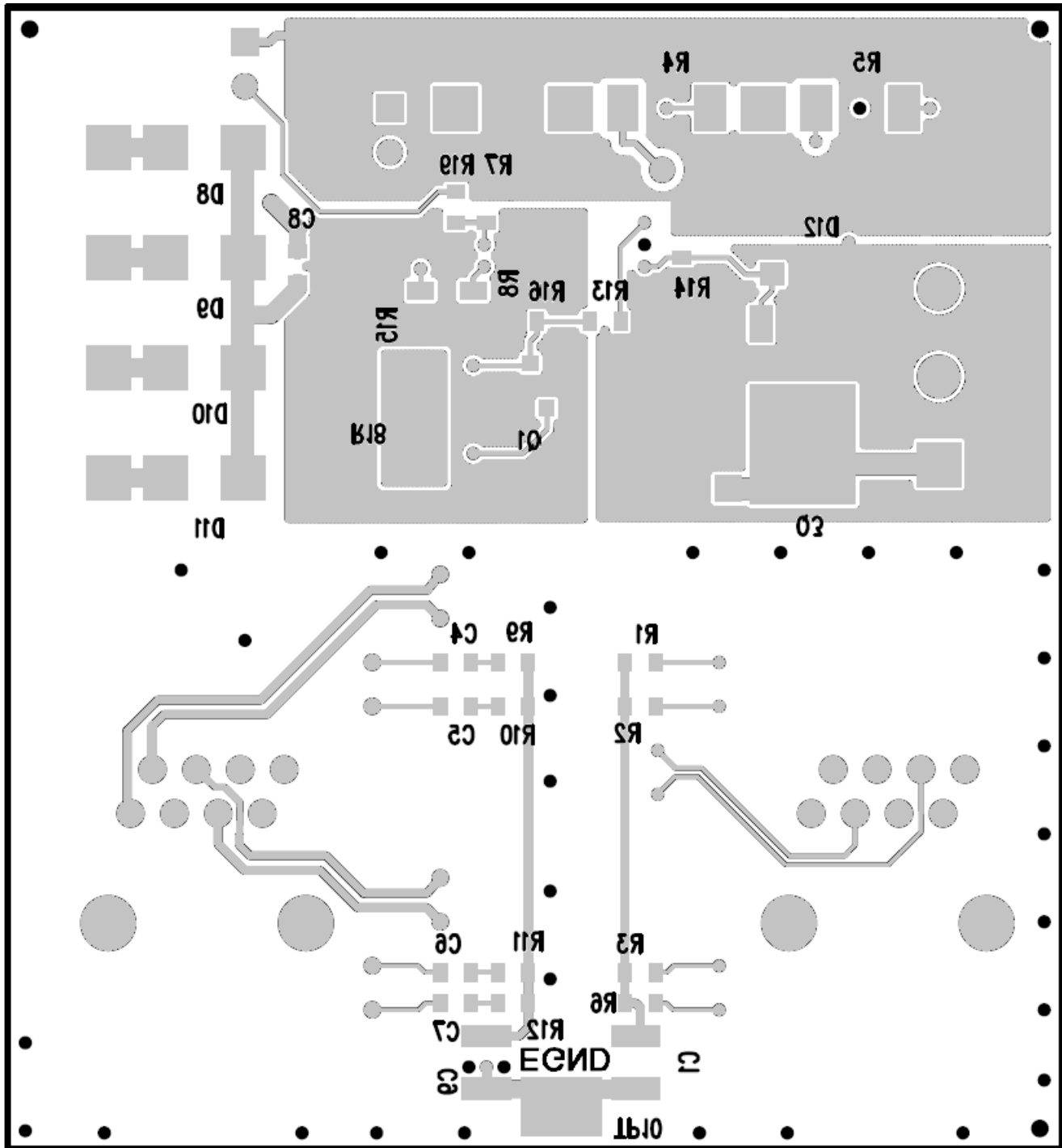

Figure 30. Recommended Layout Bottom View

11.3 Thermal Considerations and OTSD

Sources of nearby local PCB heating should be considered during the thermal design. Typical calculations assume that the TPS2379 device is the only heat source contributing to the PCB temperature rise. It is possible for a normally operating TPS2379 device to experience an OTSD event if it is excessively heated by a nearby device.

11.4 ESD

ESD requirements for a unit that incorporates the TPS2379 device have a much broader scope and operational implications than are used in TI's testing. Unit-level requirements should not be confused with reference design testing that only validates the ruggedness of the TPS2379 device.

12 器件和文档支持

12.1 文档支持

12.1.1 相关文档

相关文档如下：

- 《实现 60W、端到端 PoE 系统》，[SLVA498](#)

12.2 社区资源

The following links connect to TI community resources. Linked contents are provided "AS IS" by the respective contributors. They do not constitute TI specifications and do not necessarily reflect TI's views; see TI's [Terms of Use](#).

TI E2E™ Online Community *TI's Engineer-to-Engineer (E2E) Community*. Created to foster collaboration among engineers. At [e2e.ti.com](#), you can ask questions, share knowledge, explore ideas and help solve problems with fellow engineers.

Design Support *TI's Design Support* Quickly find helpful E2E forums along with design support tools and contact information for technical support.

12.3 商标

PowerPAD, E2E are trademarks of Texas Instruments.
All other trademarks are the property of their respective owners.

12.4 静电放电警告



这些装置包含有限的内置 ESD 保护。存储或装卸时，应将导线一起截短或将装置放置于导电泡棉中，以防止 MOS 门极遭受静电损伤。

12.5 Glossary

[SLYZ022](#) — *TI Glossary*.

This glossary lists and explains terms, acronyms, and definitions.

13 机械、封装和可订购信息

以下页中包括机械、封装和可订购信息。这些信息是针对指定器件可提供的最新数据。这些数据会在无通知且不对本文档进行修订的情况下发生改变。要获得这份数据表的浏览器版本，请查阅左侧的导航栏。

PACKAGING INFORMATION

Orderable Device	Status (1)	Package Type	Package Drawing	Pins	Package Qty	Eco Plan (2)	Lead finish/ Ball material (6)	MSL Peak Temp (3)	Op Temp (°C)	Device Marking (4/5)	Samples
TPS2379DDA	ACTIVE	SO PowerPAD	DDA	8	75	RoHS & Green	NIPDAU NIPDAUAG	Level-2-260C-1 YEAR	-40 to 85	2379	Samples
TPS2379DDAR	ACTIVE	SO PowerPAD	DDA	8	2500	RoHS & Green	NIPDAU NIPDAUAG	Level-2-260C-1 YEAR	-40 to 85	2379	Samples

(1) The marketing status values are defined as follows:

ACTIVE: Product device recommended for new designs.

LIFEBUY: TI has announced that the device will be discontinued, and a lifetime-buy period is in effect.

NRND: Not recommended for new designs. Device is in production to support existing customers, but TI does not recommend using this part in a new design.

PREVIEW: Device has been announced but is not in production. Samples may or may not be available.

OBSOLETE: TI has discontinued the production of the device.

(2) **RoHS:** TI defines "RoHS" to mean semiconductor products that are compliant with the current EU RoHS requirements for all 10 RoHS substances, including the requirement that RoHS substance do not exceed 0.1% by weight in homogeneous materials. Where designed to be soldered at high temperatures, "RoHS" products are suitable for use in specified lead-free processes. TI may reference these types of products as "Pb-Free".

RoHS Exempt: TI defines "RoHS Exempt" to mean products that contain lead but are compliant with EU RoHS pursuant to a specific EU RoHS exemption.

Green: TI defines "Green" to mean the content of Chlorine (Cl) and Bromine (Br) based flame retardants meet JS709B low halogen requirements of <=1000ppm threshold. Antimony trioxide based flame retardants must also meet the <=1000ppm threshold requirement.

(3) MSL, Peak Temp. - The Moisture Sensitivity Level rating according to the JEDEC industry standard classifications, and peak solder temperature.

(4) There may be additional marking, which relates to the logo, the lot trace code information, or the environmental category on the device.

(5) Multiple Device Markings will be inside parentheses. Only one Device Marking contained in parentheses and separated by a "~" will appear on a device. If a line is indented then it is a continuation of the previous line and the two combined represent the entire Device Marking for that device.

(6) Lead finish/Ball material - Orderable Devices may have multiple material finish options. Finish options are separated by a vertical ruled line. Lead finish/Ball material values may wrap to two lines if the finish value exceeds the maximum column width.

Important Information and Disclaimer:The information provided on this page represents TI's knowledge and belief as of the date that it is provided. TI bases its knowledge and belief on information provided by third parties, and makes no representation or warranty as to the accuracy of such information. Efforts are underway to better integrate information from third parties. TI has taken and continues to take reasonable steps to provide representative and accurate information but may not have conducted destructive testing or chemical analysis on incoming materials and chemicals. TI and TI suppliers consider certain information to be proprietary, and thus CAS numbers and other limited information may not be available for release.

In no event shall TI's liability arising out of such information exceed the total purchase price of the TI part(s) at issue in this document sold by TI to Customer on an annual basis.

TUBE



*All dimensions are nominal

Device	Package Name	Package Type	Pins	SPQ	L (mm)	W (mm)	T (μm)	B (mm)
TPS2379DDA	DDA	HSOIC	8	75	507	8	3940	4.32
TPS2379DDA	DDA	HSOIC	8	75	517	7.87	635	4.25

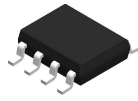

Images above are just a representation of the package family, actual package may vary.
Refer to the product data sheet for package details.

DDA0008A



PACKAGE OUTLINE

PowerPAD™ SOIC - 1.7 mm max height

PLASTIC SMALL OUTLINE

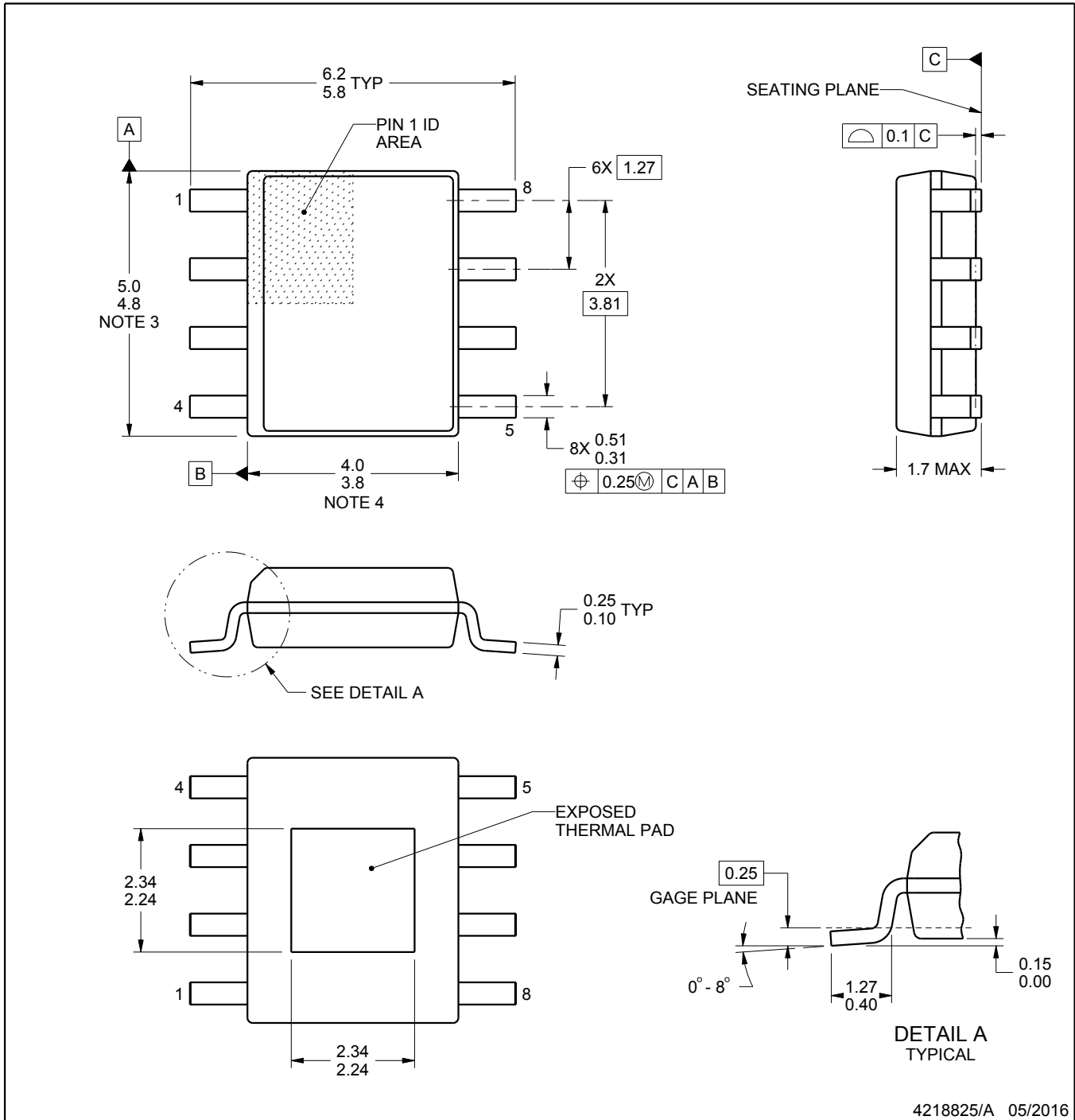

4218825/A 05/2016

PowerPAD is a trademark of Texas Instruments.

NOTES:

1. All linear dimensions are in millimeters. Any dimensions in parenthesis are for reference only. Dimensioning and tolerancing per ASME Y14.5M.
2. This drawing is subject to change without notice.
3. This dimension does not include mold flash, protrusions, or gate burrs. Mold flash, protrusions, or gate burrs shall not exceed 0.15 mm per side.
4. This dimension does not include interlead flash. Interlead flash shall not exceed 0.25 mm per side.
5. Reference JEDEC registration MS-012.

EXAMPLE BOARD LAYOUT

DDA0008A

PowerPAD™ SOIC - 1.7 mm max height

PLASTIC SMALL OUTLINE

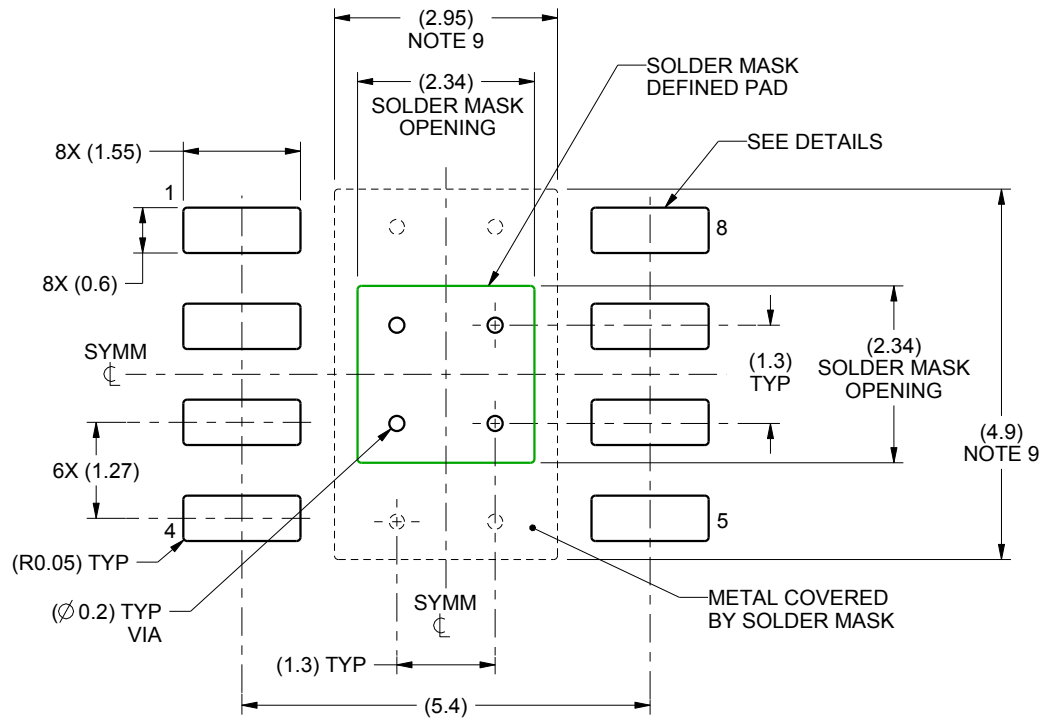

LAND PATTERN EXAMPLE
SCALE:10X

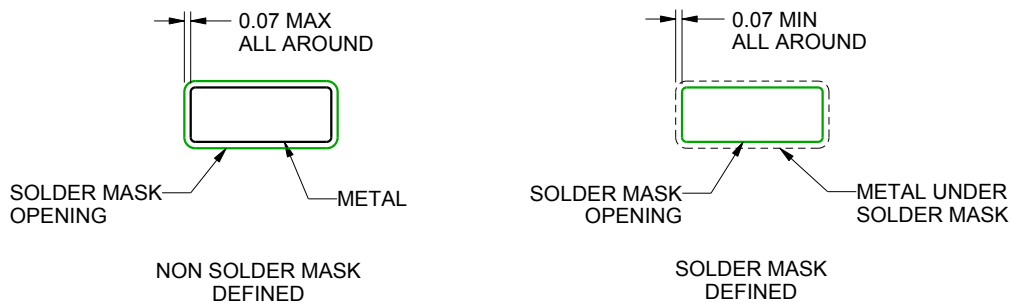

SOLDER MASK DETAILS

4218825/A 05/2016

NOTES: (continued)

6. Publication IPC-7351 may have alternate designs.
7. Solder mask tolerances between and around signal pads can vary based on board fabrication site.
8. This package is designed to be soldered to a thermal pad on the board. For more information, see Texas Instruments literature numbers SLMA002 (www.ti.com/lit/slma002) and SLMA004 (www.ti.com/lit/slma004).
9. Size of metal pad may vary due to creepage requirement.
10. Vias are optional depending on application, refer to device data sheet. If any vias are implemented, refer to their locations shown on this view. It is recommended that vias under paste be filled, plugged or tented.

EXAMPLE STENCIL DESIGN

DDA0008A

PowerPAD™ SOIC - 1.7 mm max height

PLASTIC SMALL OUTLINE

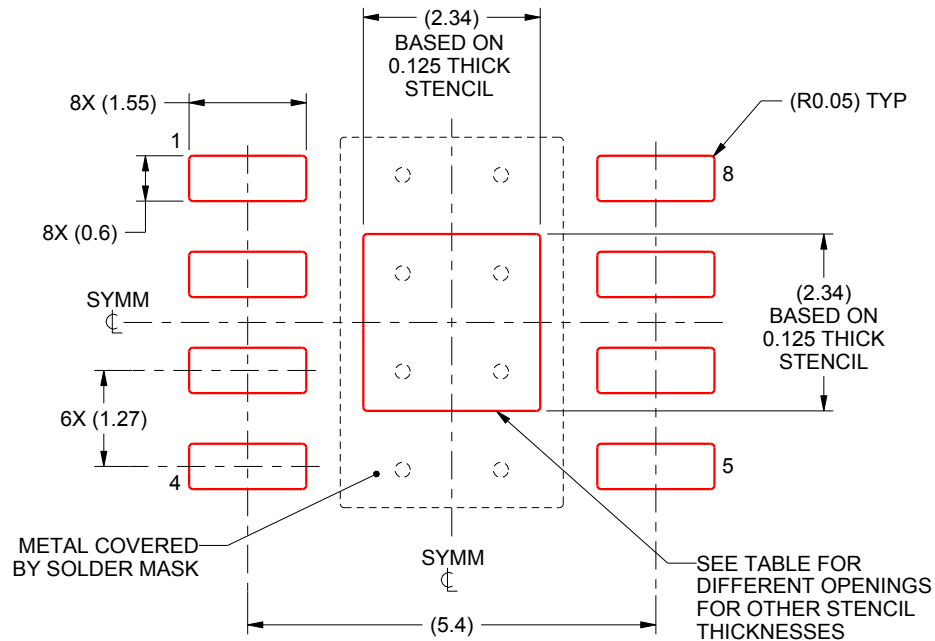

SOLDER PASTE EXAMPLE
EXPOSED PAD
100% PRINTED SOLDER COVERAGE BY AREA
SCALE:10X

STENCIL THICKNESS	SOLDER STENCIL OPENING
0.1	2.62 X 2.62
0.125	2.34 X 2.34 (SHOWN)
0.150	2.14 X 2.14
0.175	1.98 X 1.98

4218825/A 05/2016

NOTES: (continued)

11. Laser cutting apertures with trapezoidal walls and rounded corners may offer better paste release. IPC-7525 may have alternate design recommendations.
12. Board assembly site may have different recommendations for stencil design.

DDA (R-PDSO-G8)

PowerPAD™ PLASTIC SMALL-OUTLINE



4202561/F 12/11

- NOTES:
- All linear dimensions are in millimeters. Dimensioning and tolerancing per ASME Y14.5-1994.
 - This drawing is subject to change without notice.
 - Body dimensions do not include mold flash or protrusion not to exceed 0,15.
 - This package is designed to be soldered to a thermal pad on the board. Refer to Technical Brief, PowerPad Thermally Enhanced Package, Texas Instruments Literature No. SLMA002 for information regarding recommended board layout. This document is available at www.ti.com <<http://www.ti.com>>.
 - See the additional figure in the Product Data Sheet for details regarding the exposed thermal pad features and dimensions.
 - This package complies to JEDEC MS-012 variation BA

PowerPAD is a trademark of Texas Instruments.

DDA (R-PDSO-G8)

PowerPAD™ PLASTIC SMALL OUTLINE

THERMAL INFORMATION

This PowerPAD™ package incorporates an exposed thermal pad that is designed to be attached to a printed circuit board (PCB). The thermal pad must be soldered directly to the PCB. After soldering, the PCB can be used as a heatsink. In addition, through the use of thermal vias, the thermal pad can be attached directly to the appropriate copper plane shown in the electrical schematic for the device, or alternatively, can be attached to a special heatsink structure designed into the PCB. This design optimizes the heat transfer from the integrated circuit (IC).

For additional information on the PowerPAD package and how to take advantage of its heat dissipating abilities, refer to Technical Brief, PowerPAD Thermally Enhanced Package, Texas Instruments Literature No. SLMA002 and Application Brief, PowerPAD Made Easy, Texas Instruments Literature No. SLMA004. Both documents are available at www.ti.com.

The exposed thermal pad dimensions for this package are shown in the following illustration.



Exposed Thermal Pad Dimensions

4206322-6/L 05/12

NOTE: A. All linear dimensions are in millimeters

PowerPAD is a trademark of Texas Instruments



- NOTES:
- A. All linear dimensions are in millimeters.
 - B. This drawing is subject to change without notice.
 - C. Publication IPC-7351 is recommended for alternate designs.
 - D. This package is designed to be soldered to a thermal pad on the board. Refer to Technical Brief, PowerPad Thermally Enhanced Package, Texas Instruments Literature No. SLMA002, SLMA004, and also the Product Data Sheets for specific thermal information, via requirements, and recommended board layout. These documents are available at www.ti.com <<http://www.ti.com>>. Publication IPC-7351 is recommended for alternate designs.
 - E. Laser cutting apertures with trapezoidal walls and also rounding corners will offer better paste release. Customers should contact their board assembly site for stencil design recommendations. Example stencil design based on a 50% volumetric metal load solder paste. Refer to IPC-7525 for other stencil recommendations.
 - F. Customers should contact their board fabrication site for solder mask tolerances between and around signal pads.

PowerPAD is a trademark of Texas Instruments.

重要声明和免责声明

TI“按原样”提供技术和可靠性数据（包括数据表）、设计资源（包括参考设计）、应用或其他设计建议、网络工具、安全信息和其他资源，不保证没有瑕疵且不做任何明示或暗示的担保，包括但不限于对适销性、某特定用途方面的适用性或不侵犯任何第三方知识产权的暗示担保。

这些资源可供使用 TI 产品进行设计的熟练开发人员使用。您将自行承担以下全部责任：(1) 针对您的应用选择合适的 TI 产品，(2) 设计、验证并测试您的应用，(3) 确保您的应用满足相应标准以及任何其他功能安全、信息安全、监管或其他要求。

这些资源如有变更，恕不另行通知。TI 授权您仅可将这些资源用于研发本资源所述的 TI 产品的应用。严禁对这些资源进行其他复制或展示。您无权使用任何其他 TI 知识产权或任何第三方知识产权。您应全额赔偿因在这些资源的使用中对 TI 及其代表造成的任何索赔、损害、成本、损失和债务，TI 对此概不负责。

TI 提供的产品受 [TI 的销售条款](#) 或 [ti.com](#) 上其他适用条款/TI 产品随附的其他适用条款的约束。TI 提供这些资源并不会扩展或以其他方式更改 TI 针对 TI 产品发布的适用的担保或担保免责声明。

TI 反对并拒绝您可能提出的任何其他或不同的条款。

邮寄地址：Texas Instruments, Post Office Box 655303, Dallas, Texas 75265

Copyright © 2023，德州仪器 (TI) 公司