

## 采用芯片级封装的 TPS61256xC 3.5 MHz 高效升压转换器

### 1 特性

- 频率为 3.5MHz 时，工作效率达 93%
- 正常运行时的静态电流为 37 $\mu$ A
- 2.3V 至 5.5V 的宽输入电压范围
- 支持  $V_{IN} \geq V_{OUT}$  的工作模式
- DC 电压输出总精度为  $\pm 2\%$
- 轻负载频率脉冲调制 (PFM) 模式
- 通过拉低 EN 支持直通模式
- 热关断和过载保护
- 只需三个表面贴装外部组件
- 总解决方案尺寸 < 25mm<sup>2</sup>
- 9 引脚 NanoFree™(CSP) 封装内

### 2 应用

- NFC PA 电源
- 手机、智能电话
- 单声道和立体声 APA 应用
- USB 充电端口

### 3 说明

TPS61256xC 器件为电池供电类便携式 优化提供了一个电源解决方案。适用于低功耗 应用的 TPS61256xC 支持来自一节电池（放电电压低至 2.65V）的高达 800mA 的负载电流，并且允许使用低成本芯片电感器和电容器。

借助 2.3V-5.5V 的宽输入电压范围，该器件支持由各种电压的锂离子电池进行供电的应用。可提供 3.15V 到 5.0V 之间的不同固定电压输出版本。

TPS61256xC 在 3.5MHz 的调节开关频率下运行，在轻负载电流情况下会进入省电模式，以便在整个负载电流范围内保持高效率。PFM 模式可在轻负载工作时将静态电流降至 37 $\mu$ A（典型值），从而可延长电池使用寿命。

此外，TPS61256xC 器件还可通过将 EN 拉至低电平来支持直通模式。在这种模式下，输出电压跟随输入电压变化，由电感器和高侧 FET 的电阻来降低电压。

TPS61256xC 最大限度地减少了外部组件的数量，因此拥有非常小巧的解决方案尺寸。为了实现小解决方案尺寸，它允许使用小型电感器和输入电容器。

#### 器件信息(1)

器件型号	封装	封装尺寸 (标称值)
TPS61256xC	DSBGA (9)	1.206mm x 1.306mm

(1) 如需了解所有可用封装，请参阅产品说明书末尾的可订购产品附录。

效率与负载电流间的关系

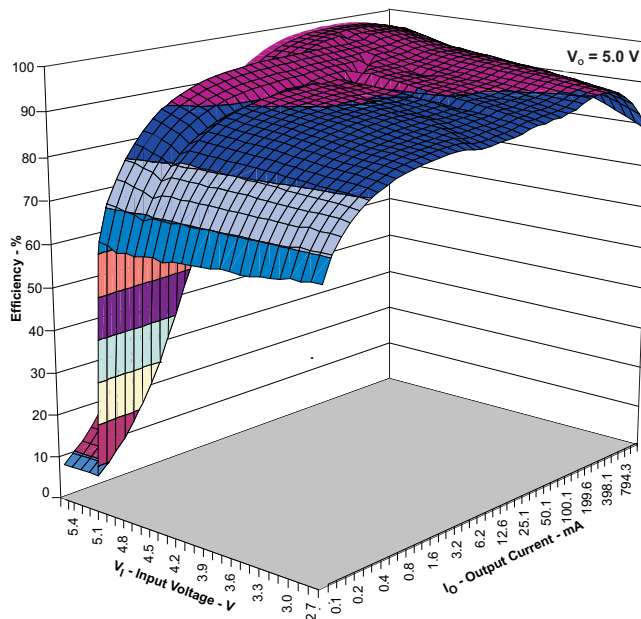

## 目录

<p><b>1 特性</b> ..... 1</p> <p><b>2 应用</b> ..... 1</p> <p><b>3 说明</b> ..... 1</p> <p><b>4 修订历史记录</b> ..... 2</p> <p><b>5 Device Options</b> ..... 3</p> <p><b>6 Pin Configuration and Functions</b> ..... 3</p> <p><b>7 Specifications</b> ..... 4</p> <p>  7.1 Absolute Maximum Ratings ..... 4</p> <p>  7.2 ESD Ratings ..... 4</p> <p>  7.3 Recommended Operating Conditions ..... 4</p> <p>  7.4 Thermal Information ..... 4</p> <p>  7.5 Electrical Characteristics ..... 5</p> <p>  7.6 Typical Characteristics ..... 6</p> <p><b>8 Parameter Measurement Information</b> ..... 7</p> <p><b>9 Detailed Description</b> ..... 8</p> <p>  9.1 Overview ..... 8</p> <p>  9.2 Functional Block Diagram ..... 8</p> <p>  9.3 Feature Description ..... 9</p>	<p>  9.4 Device Functional Modes ..... 10</p> <p><b>10 Application and Implementation</b> ..... 12</p> <p>  10.1 Application Information ..... 12</p> <p>  10.2 Typical Application ..... 12</p> <p><b>11 Power Supply Recommendations</b> ..... 18</p> <p><b>12 Layout</b> ..... 18</p> <p>  12.1 Layout Guidelines ..... 18</p> <p>  12.2 Layout Example ..... 18</p> <p>  12.3 Thermal Considerations ..... 19</p> <p><b>13 器件和文档支持</b> ..... 20</p> <p>  13.1 器件支持 ..... 20</p> <p>  13.2 接收文档更新通知 ..... 20</p> <p>  13.3 社区资源 ..... 20</p> <p>  13.4 商标 ..... 20</p> <p>  13.5 静电放电警告 ..... 20</p> <p>  13.6 Glossary ..... 20</p> <p><b>14 机械、封装和可订购信息</b> ..... 21</p> <p>  14.1 封装概要 ..... 21</p> <p>  14.2 Package Option Addendum ..... 22</p>
--	--

## 4 修订历史记录

注：之前版本的页码可能与当前版本有所不同。

Changes from Original (February 2017) to Revision A	Page
• Added device numbers TPS612562C and TPS612564C .....	3

## 5 Device Options

T <sub>A</sub>	PART NUMBER <sup>(1)</sup>	OUTPUT VOLTAGE	DEVICE SPECIFIC FEATURES
–40°C to 85°C	TPS61256C	5.0 V	Supports 5 V / 900 mA loading down to 3.3 V input voltage
–40°C to 85°C	TPS612562C	5.2 V	Supports 5.2 V / 900 mA loading down to 3.3 V input voltage
–40°C to 85°C	TPS612564C	5.4 V	Supports 5.4 V / 900 mA loading down to 3.3 V input voltage

(1) For all available packages, see the orderable addendum at the end of the datasheet.

## 6 Pin Configuration and Functions

**YFF Package  
9-Bump DSBGA  
Top and Bottom Views**

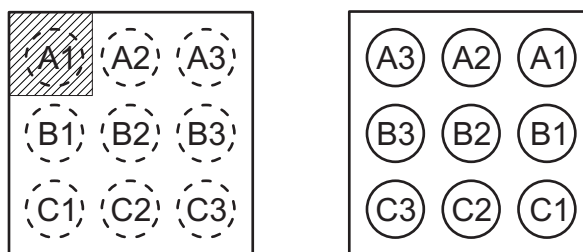

**Pin Functions**

PIN		I/O	DESCRIPTION
NAME	NO.		
EN	B3	I	EN = high, the device works in the boost mode. EN = low, the device is in pass-through mode. This pin must not be left floating and must be terminated.
GND	C1, C2, C3		Ground pin.
SW	B1, B2	I/O	This is the switch pin of the converter and is connected to the drain of the internal Power MOSFETs.
VIN	A3	I	Power supply input.
VOUT	A1, A2	O	Boost converter output.

## 7 Specifications

### 7.1 Absolute Maximum Ratings

over operating free-air temperature range (unless otherwise noted)<sup>(1)</sup>

		MIN	MAX	UNIT
Input voltage	Voltage at VIN <sup>(2)</sup> , VOUT <sup>(2)</sup> , SW <sup>(2)</sup> , EN <sup>(2)</sup>	-0.3	7	V
Input current	Continuous average current into SW <sup>(3)</sup>	1.8		A
	Peak current into SW <sup>(4)</sup>	3.5		
Power dissipation		Internally limited		
Temperature	Operating, T <sub>A</sub> <sup>(5)</sup>	-40	85	°C
	Operating virtual junction, T <sub>J</sub>	-40	150	
	Storage, T <sub>stg</sub>	-65	150	

- Stresses beyond those listed under *absolute maximum ratings* may cause permanent damage to the device. These are stress ratings only, and functional operation of the device at these or any other conditions beyond those indicated under *recommended operating conditions* is not implied. Exposure to absolute-maximum-rated conditions for extended periods may affect device reliability.
- All voltages are with respect to network ground terminal.
- Limit the junction temperature to 105°C for continuous operation at maximum output power.
- Limit the junction temperature to 125°C for 5% duty cycle operation.
- In applications where high power dissipation and/or poor package thermal resistance is present, the maximum ambient temperature may have to be derated. Maximum ambient temperature (T<sub>A(max)</sub>) is dependent on the maximum operating junction temperature (T<sub>J(max)</sub>), the maximum power dissipation of the device in the application (P<sub>D(max)</sub>), and the junction-to-ambient thermal resistance of the part/package in the application (θ<sub>JA</sub>), as given by the following equation: T<sub>A(max)</sub> = T<sub>J(max)</sub> - (θ<sub>JA</sub> × P<sub>D(max)</sub>). To achieve optimum performance, it is recommended to operate the device with a maximum junction temperature of 105°C.

### 7.2 ESD Ratings

		VALUE	UNIT
V <sub>(ESD)</sub> Electrostatic discharge	Human-body model (HBM), per ANSI/ESDA/JEDEC JS-001 <sup>(1)</sup>	±2000	V
	Charged-device model (CDM), per JEDEC specification JESD22-C101 <sup>(2)</sup>	±1000	
	Machine model (MM)	±200	

- JEDEC document JEP155 states that 500-V HBM allows safe manufacturing with a standard ESD control process. Manufacturing with less than 500-V HBM is possible with the necessary precautions.
- JEDEC document JEP157 states that 250-V CDM allows safe manufacturing with a standard ESD control process. Manufacturing with less than 250-V CDM is possible with the necessary precautions.

### 7.3 Recommended Operating Conditions

			MIN	NOM	MAX	UNIT
V <sub>I</sub>	Input voltage range	TPS61256xC	2.5		4.85	V
R <sub>L</sub>	Minimum resistive load for start-up	TPS61256xC	10			Ω
L	Inductance		0.7	1.0	2.9	μH
C <sub>O</sub>	Output capacitance		3.5	5	50	μF
T <sub>A</sub>	Ambient temperature		-40		85	°C
T <sub>J</sub>	Operating junction temperature		-40		125	°C

### 7.4 Thermal Information

THERMAL METRIC <sup>(1)</sup>		TPS61256xC		UNIT
		YFF		
		9 PINS		
R <sub>θJA</sub>	Junction-to-ambient thermal resistance	108.3		°C/W
R <sub>θJC(top)</sub>	Junction-to-case (top) thermal resistance	1.0		°C/W
R <sub>θJB</sub>	Junction-to-board thermal resistance	18		°C/W
ψ <sub>JT</sub>	Junction-to-top characterization parameter	4.2		°C/W
ψ <sub>JB</sub>	Junction-to-board characterization parameter	17.9		°C/W

- For more information about traditional and new thermal metrics, see the *IC Package Thermal Metrics* application report ([SPRA953](#)).

## 7.5 Electrical Characteristics

Minimum and maximum values are at  $V_{IN} = 2.3V$  to  $5.5V$ ,  $EN = 1.8V$ ,  $T_A = -40^{\circ}C$  to  $85^{\circ}C$ ; Circuit of Parameter Measurement Information section (unless otherwise noted). Typical values are at  $V_{IN} = 3.6V$ ,  $EN = 1.8V$ ,  $T_A = 25^{\circ}C$  (unless otherwise noted).

PARAMETER		TEST CONDITIONS	MIN	TYP	MAX	UNIT
<b>SUPPLY CURRENT</b>						
$I_Q$	Operating quiescent current into $V_{IN}$	Operating quiescent current into $V_{IN}$	$I_{OUT} = 0$ mA, $V_{IN} = 3.6$ V $EN = V_{IN}$ Device not switching	30	45	$\mu A$
				7	15	$\mu A$
	pass-through mode quiescent current into $V_{IN}$	pass-through mode quiescent current into $V_{OUT}$	$I_{OUT} = 0$ mA, $V_{IN} = V_{OUT} = 3.6$ V $EN = GND$ , Device not switching	11	20	$\mu A$
				9.5	15	$\mu A$
$V_{UVLO}$	Under-voltage lockout threshold	Falling	2.0	2.1	V	
		Hysteresis	0.1		V	
<b>ENABLE</b>						
$V_{IL\_EN}$	Low-level input voltage				0.4	V
$V_{IH\_EN}$	High-level input voltage		1.0			V
$I_{lkg\_EN}$	Input leakage current	Input connected to GND or $V_{IN}$			0.5	$\mu A$
<b>OUTPUT</b>						
$V_{OUT}$	Regulated DC output voltage-TPS61256C	$2.3 V \leq V_{IN} \leq 4.85 V$ , $I_{OUT} = 0$ mA PWM operation. Open Loop	4.92	5	5.08	V
$V_{OUT}$	Regulated DC output voltage-TPS612562C	$2.3 V \leq V_{IN} \leq 4.85 V$ , $I_{OUT} = 0$ mA PWM operation. Open Loop	5.12	5.2	5.28	V
$V_{OUT}$	Regulated DC output voltage-TPS612564C	$2.3 V \leq V_{IN} \leq 4.85 V$ , $I_{OUT} = 0$ mA PWM operation. Open Loop	5.31	5.4	5.49	V
$\Delta V_{OUT}$	Power-save mode output ripple voltage	PFM operation, $I_{OUT} = 1$ mA		50		mVpk
<b>POWER SWITCH</b>						
$r_{DS(on)}$	High-side MOSFET on resistance			170		m $\Omega$
	Low-side MOSFET on resistance			100		
$I_{LIM}$	Switch valley current limit	$EN = V_{IN}$ , Open Loop	1900	2150	2400	mA
	Pre-charge / pass-through mode current limit (linear mode)	TPS61256xC	500			
	Overtemperature protection			140		$^{\circ}C$
	Overtemperature hysteresis			20		$^{\circ}C$
<b>OSCILLATOR</b>						
$f_{OSC}$	Oscillator frequency	$V_{IN} = 3.6$ V, $V_{OUT} = 4.5$ V		3.5		MHz
<b>TIMING</b>						
Start-up time		$I_{OUT} = 0$ mA. Time from active EN to start switching		70		$\mu s$
		$I_{OUT} = 0$ mA. Time from active EN to $V_{OUT}$		400		$\mu s$

## 7.6 Typical Characteristics

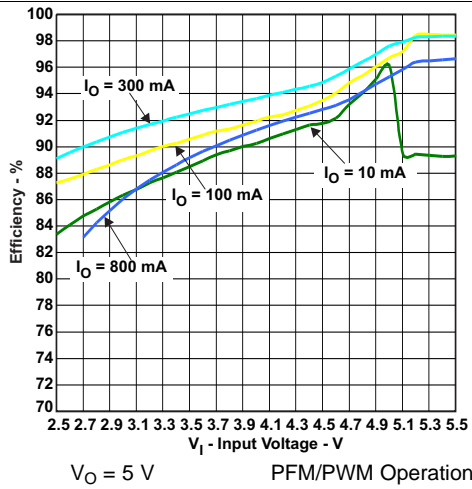

Figure 1. Efficiency vs Input Voltage

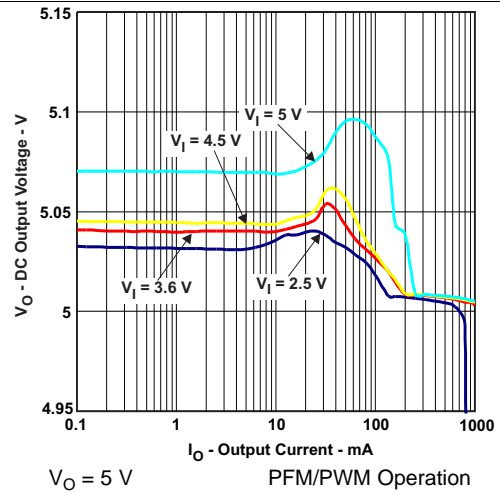

Figure 2. DC Output Voltage vs Output Current

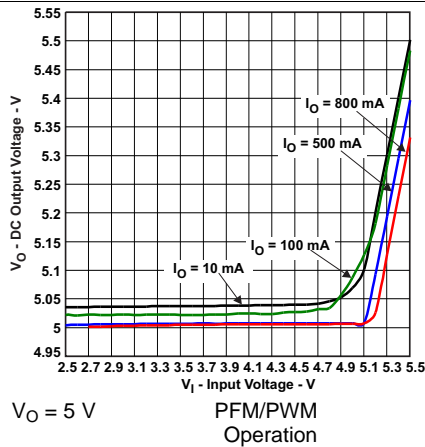

Figure 3. DC Output Voltage vs Input Voltage

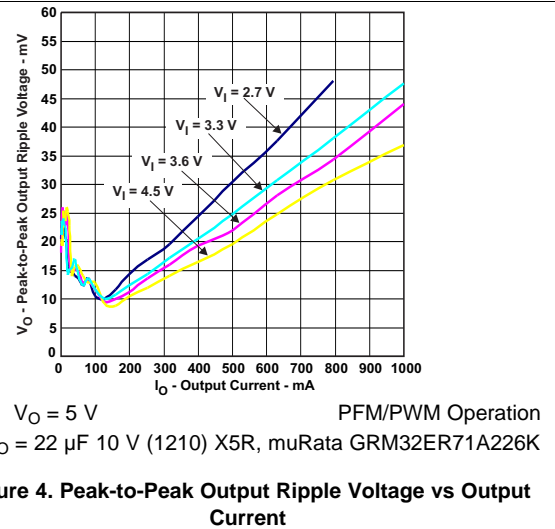

Figure 4. Peak-to-Peak Output Ripple Voltage vs Output Current

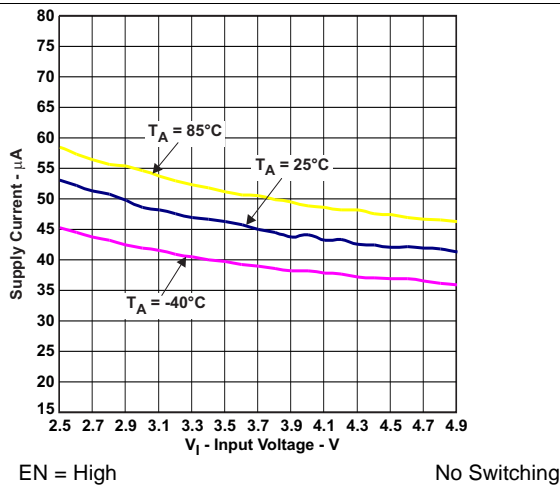

Figure 5. Supply Current vs Input Voltage

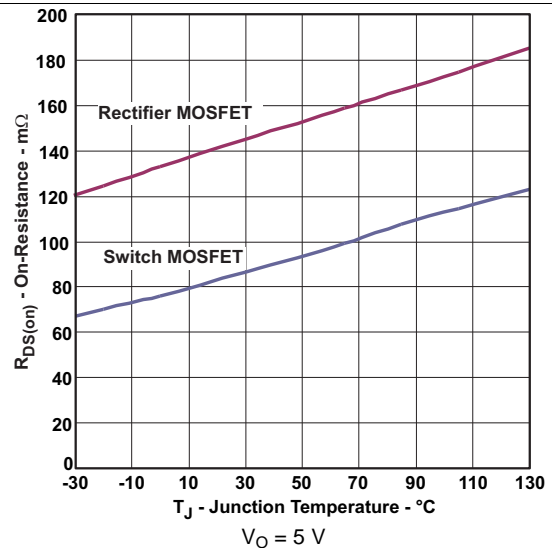
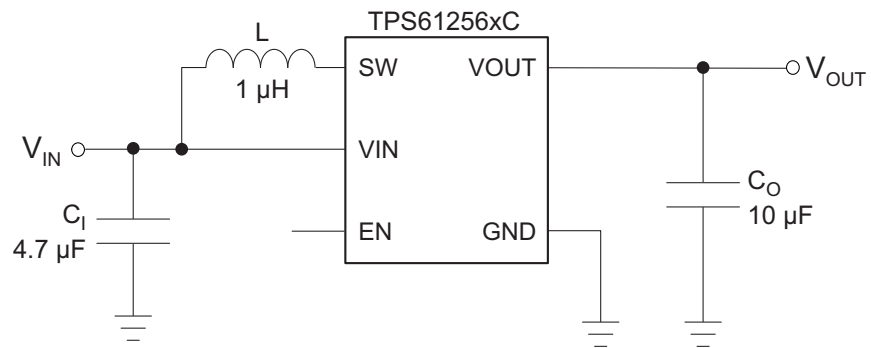

Figure 6. MOSFET  $r_{DS(on)}$  vs Temperature

## 8 Parameter Measurement Information



Copyright © 2017, Texas Instruments Incorporated

**Figure 7. Parameter Measurement Schematic**

## 9 Detailed Description

### 9.1 Overview

The TPS61256xC synchronous step-up converter typically operates at a quasi-constant 3.5-MHz frequency pulse width modulation (PWM) at moderate to heavy load currents. At light load currents, the TPS61256xC converter operates in power-save mode with pulse frequency modulation (PFM).

During PWM operation, the converter uses a novel quasi-constant on-time valley current mode control scheme to achieve excellent line/load regulation and allows the use of a small ceramic inductor and capacitors. Based on the  $V_{IN}/V_{OUT}$  ratio, a simple circuit predicts the required on-time.

At the beginning of the switching cycle, the low-side N-MOS switch is turned-on and the inductor current ramps up to a peak current that is defined by the on-time and the inductance. In the second phase, once the on-timer has expired, the rectifier is turned-on and the inductor current decays to a preset valley current threshold. Finally, the switching cycle repeats by setting the on timer again and activating the low-side N-MOS switch.

In general, a dc/dc step-up converter can only operate in "true" boost mode, i.e. the output "boosted" by a certain amount above the input voltage. The TPS61256xC device operates differently as it can smoothly transition in and out of zero duty cycle operation. Therefore the output can be kept as close as possible to its regulation limits even though the converter is subject to an input voltage that tends to be excessive. In this operation mode, the output current capability of the regulator is limited to 500 mA (min.). Refer to [Figure 3](#) for further details.

The current mode architecture with adaptive slope compensation provides excellent transient load response, requiring minimal output filtering. Internal soft-start and loop compensation simplifies the design process while minimizing the number of external components.

### 9.2 Functional Block Diagram

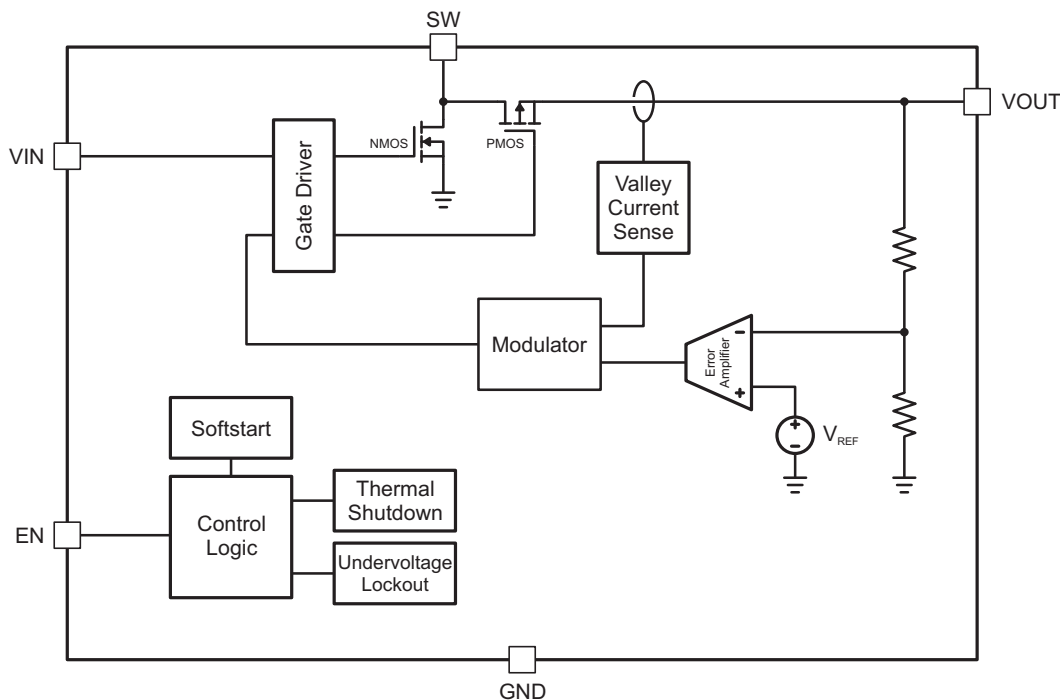

Copyright © 2016, Texas Instruments Incorporated



### 9.3 Feature Description

#### 9.3.1 Current Limit Operation

The TPS61256xC device employs a valley current limit sensing scheme. Current limit detection occurs during the off-time by sensing of the voltage drop across the synchronous rectifier.

The output voltage is reduced as the power stage of the device operates in a constant current mode. The maximum continuous output current ( $I_{OUT(CL)}$ ), before entering current limit (CL) operation, can be defined by Equation 1.

$$I_{OUT(CL)} = (1 - D) \cdot (I_{VALLEY} + \frac{1}{2} \Delta I_L) \tag{1}$$

The duty cycle (D) can be estimated by Equation 2

$$D = 1 - \frac{V_{IN} \cdot \eta}{V_{OUT}} \tag{2}$$

and the peak-to-peak current ripple ( $\Delta I_L$ ) is calculated by Equation 3

$$\Delta I_L = \frac{V_{IN}}{L} \cdot \frac{D}{f} \tag{3}$$

The output current,  $I_{OUT(DC)}$ , is the average of the rectifier ripple current waveform. When the load current is increased such that the lower peak is above the current limit threshold, the off-time is increased to allow the current to decrease to this threshold before the next on-time begins (so called frequency fold-back mechanism). When the current limit is reached the output voltage decreases during further load increase.

Figure 8 illustrates the inductor and rectifier current waveforms during current limit operation.

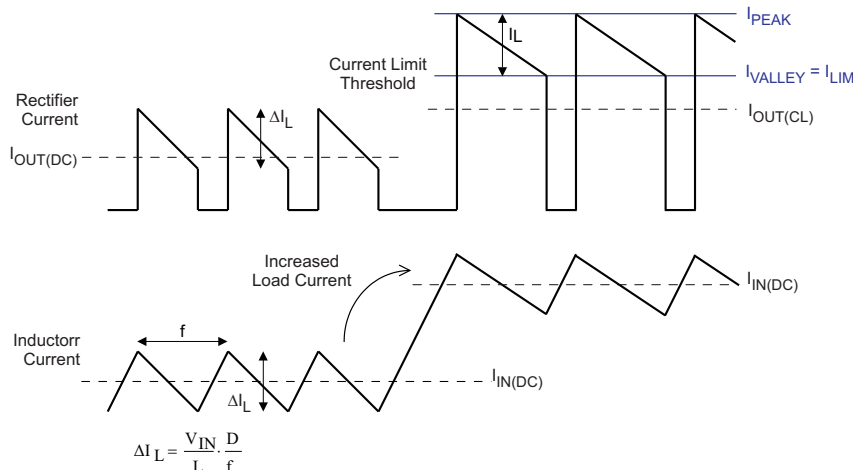

**Figure 8. Inductor/Rectifier Currents in Current Limit Operation**

#### 9.3.2 Enable

The TPS61256xC device starts operation when EN is set high and starts up with the soft-start sequence. For proper operation, the EN pin must be terminated and must not be left floating.

Pulling the EN low and  $V_{in}$  above UVLO, the device is in the forced pass-through mode and the output voltage follows the input voltage (with a voltage drop of the inductor DCR and  $R_{dson}$  of HS FET).

#### 9.3.3 Softstart

The TPS61256xC device has an internal softstart circuit that limits the inrush current during start-up. The first step in the start-up cycle is the pre-charge phase. During pre-charge, the rectifying switch is turned on until the output capacitor is charged to a value close to the input voltage. The rectifying switch is current limited (500 mA min.) during this phase. This mechanism is used to limit the output current under short-circuit condition.

## Feature Description (continued)

Once the output capacitor has been biased to the input voltage, the converter starts switching. The soft-start system progressively increases the on-time as a function of the input-to-output voltage ratio. As soon as the output voltage is reached, the regulation loop takes control and full current operation is permitted.

The TPS61256xC works in the pass-through mode when EN is low and  $V_{IN}$  above UVLO, the device enters into the boost switching phase directly when EN becomes high.

### 9.3.4 Undervoltage Lockout

The under voltage lockout circuit prevents the device from malfunctioning at low input voltages and the battery from excessive discharge. It disables the output stage of the converter once the falling  $V_{IN}$  trips the under-voltage lockout threshold  $V_{UVLO}$  which is typically 2.0V. The device starts operation once the rising  $V_{IN}$  trips  $V_{UVLO}$  threshold plus its hysteresis of 100 mV at typically 2.1 V.

### 9.3.5 Thermal Regulation

The TPS61256xC device contains a thermal regulation loop that monitors the die temperature during the pre-charge phase. If the die temperature rises to high values of about 110 °C, the device automatically reduces the current to prevent the die temperature from increasing further. Once the die temperature drops about 10 °C below the threshold, the device automatically increases the current to the target value. This function also reduces the current during a short-circuit condition.

### 9.3.6 Thermal Shutdown

As soon as the junction temperature,  $T_J$ , exceeds 140°C (typ.) the device goes into thermal shutdown. In this mode, the high-side and low-side MOSFETs are turned-off. When the junction temperature falls below the thermal shutdown minus its hysteresis, the device continuous the operation.

## 9.4 Device Functional Modes

### 9.4.1 Power Save Mode

The TPS61256xC integrates a power save mode to improve efficiency at light load. In power save mode the converter only operates when the output voltage trips below a set threshold voltage.

The TPS61256xC ramps up the output voltage with several pulses and goes into power save mode once the output voltage exceeds the set threshold voltage.

The PFM mode is exited and PWM mode entered when the output current can no longer be supported in PFM mode.

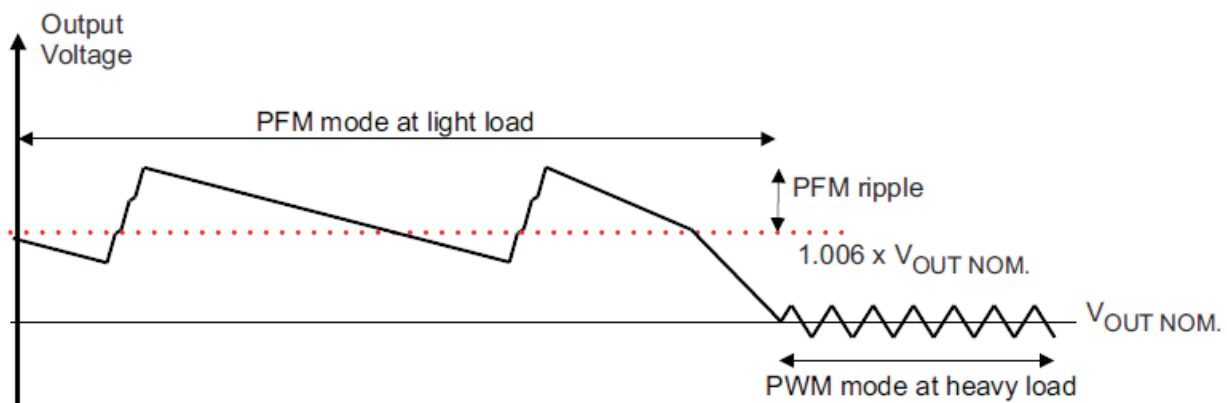

Figure 9. Power Save

## Device Functional Modes (continued)

### 9.4.2 Pass-Through Mode

When EN is pulled to low and  $V_{in}$  above UVLO, the device works in the pass-through mode and the output voltage of TPS61256xC follows the input voltage level. In so called pass-through mode, the synchronous rectifier is current limited to 500 mA (min.). The output voltage is slightly reduced due to voltage drop across the rectifier MOSFET and the inductor DC resistance.

## 10 Application and Implementation

### NOTE

Information in the following applications sections is not part of the TI component specification, and TI does not warrant its accuracy or completeness. TI's customers are responsible for determining suitability of components for their purposes. Customers should validate and test their design implementation to confirm system functionality.

### 10.1 Application Information

With a wide input voltage range of 2.3 V to 5.5 V, the TPS61256xC supports applications powered by Li-Ion batteries with extended voltage range. Intended for low-power applications, it supports up to 800-mA load current from a battery discharged as low as 2.65 V and allows the use of low cost chip inductor and capacitors. Different fixed voltage output versions are available from 3.15 V to 5.0 V. The TPS61256xC offers a very small solution size due to minimum amount of external components. The TPS6125xC allows the use of small inductors and input capacitors to achieve a small solution size. During the pass-through mode, the output voltage is biased to the input voltage.

### 10.2 Typical Application

This section details an application with TPS61256xC to output fixed 5.0 V.

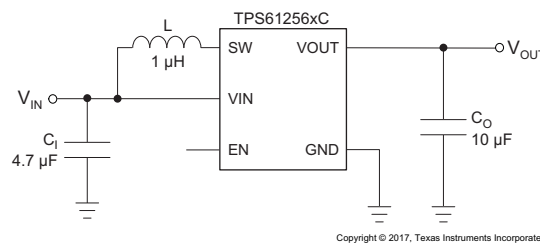

**Figure 10. Smallest Solution Size Application**

#### 10.2.1 Design Requirements

In this example, TPS61256xC is used to design a 5-V power supply with up to 800-mA output current capability. The TPS61256xC can be powered by one-cell Li-ion battery, and in this example the input voltage range is from 2.65 V to 4.85 V.

#### 10.2.2 Detailed Design Procedure

**Table 1. List of Components**

REFERENCE	DESCRIPTION	PART NUMBER, MANUFACTURER <sup>(1)</sup>
L <sup>(2)</sup>	1.0 µH, 1.8 A, 48 mΩ, 3.2 x 2.5 x 1.0mm max. height	LQM32PN1R0MG0, muRata
C <sub>1</sub>	4.7 µF, 6.3 V, 0402, X5R ceramic	GRM155R60J475M, muRata
C <sub>O</sub>	10 µF, 6.3 V, 0603, X5R ceramic	GRM188R60J106ME84, muRata

(1) See [Third-Party Products Disclaimer](#)

(2) Inductor used to characterize TPS61256xCYFF device.

##### 10.2.2.1 Inductor Selection

A boost converter normally requires two main passive components for storing energy during the conversion, an inductor and an output capacitor. TI advises selecting an inductor with a saturation current rating higher than the possible peak current flowing through the power switches.

The inductor peak current varies as a function of the load, the input and output voltages and can be estimated using [Equation 4](#).

$$I_{L(\text{PEAK})} = \frac{V_{\text{IN}} \cdot D}{2 \cdot f \cdot L} + \frac{I_{\text{OUT}}}{(1-D) \cdot \eta} \quad \text{with} \quad D = 1 - \frac{V_{\text{IN}} \cdot \eta}{V_{\text{OUT}}} \quad (4)$$

Selecting an inductor with insufficient saturation performance can lead to excessive peak current in the converter. This could eventually harm the device and reduce its reliability.

When selecting the inductor, as well as the inductance, parameters of importance are: maximum current rating, series resistance, and operating temperature. The inductor DC current rating should be greater (by some margin) than the maximum input average current, refer to [Equation 5](#) and [Current Limit Operation](#) section for more details.

$$I_{L(DC)} = \frac{V_{OUT}}{V_{IN}} \cdot \frac{1}{\eta} \cdot I_{OUT} \quad (5)$$

The TPS61256xC series of step-up converters have been optimized to operate with a effective inductance in the range of 0.7  $\mu$ H to 2.9  $\mu$ H and with output capacitors in the range of 10  $\mu$ F to 47  $\mu$ F. The internal compensation is optimized for an output filter of  $L = 1 \mu$ H and  $C_O = 10 \mu$ F. Larger or smaller inductor values can be used to optimize the performance of the device for specific operating conditions. For more details, see the [Checking Loop Stability](#) section.

In high-frequency converter applications, the efficiency is essentially affected by the inductor AC resistance (i.e. quality factor) and to a smaller extent by the inductor DCR value. To achieve high efficiency operation, care should be taken in selecting inductors featuring a quality factor above 25 at the switching frequency. Increasing the inductor value produces lower RMS currents, but degrades transient response. For a given physical inductor size, increased inductance usually results in an inductor with lower saturation current.

The total losses of the coil consist of both the losses in the DC resistance,  $R_{(DC)}$ , and the following frequency-dependent components:

- The losses in the core material (magnetic hysteresis loss, especially at high switching frequencies)
- Additional losses in the conductor from the skin effect (current displacement at high frequencies)
- Magnetic field losses of the neighboring windings (proximity effect)
- Radiation losses

The following inductor series from different suppliers have been used with the TPS61256xC converters.

**Table 2. List of Inductors**

MANUFACTURER <sup>(1)</sup>	SERIES	DIMENSIONS (in mm)
HITACHI METALS	KSLI-322512BL1-1R0	3.2 x 2.5 x 1.2 max. height
MURATA	LQM32PN1R0MG0	3.2 x 2.5 x 1.0 max. height
	LQM2HPN1R0MG0	2.5 x 2.0 x 1.0 max. height
	LQM21PN1R5MC0	2.0 x 1.2 x 0.55 max height
TOKO	DFE322512C-1R0	3.2 x 2.5 x 1.2 max. height
	MDT2012-CLR1R0AM	2.0 x 1.2 x 0.58 max height

(1) See [Third-Party Products Disclaimer](#)

### 10.2.2.2 Output Capacitor

For the output capacitor, TI recommends using small ceramic capacitors placed as close as possible to the V<sub>OUT</sub> and GND pins of the IC. If, for any reason, the application requires the use of large capacitors which can not be placed close to the IC, using a smaller ceramic capacitor in parallel to the large one is highly recommended. This small capacitor should be placed as close as possible to the V<sub>OUT</sub> and GND pins of the IC. To get an estimate of the recommended minimum output capacitance, [Equation 6](#) can be used.

$$C_{MIN} = \frac{I_{OUT} \cdot (V_{OUT} - V_{IN})}{f \cdot \Delta V \cdot V_{OUT}} \quad (6)$$

Where  $f$  is the switching frequency which is 3.5 MHz (typ.) and  $\Delta V$  is the maximum allowed output ripple.

With a chosen ripple voltage of 20mV, a minimum effective capacitance of 9  $\mu$ F is needed. The total ripple is larger due to the ESR of the output capacitor. This additional component of the ripple can be calculated using [Equation 7](#)

$$V_{ESR} = I_{OUT} \cdot R_{ESR} \quad (7)$$

An MLCC capacitor with twice the value of the calculated minimum should be used due to DC bias effects. This is required to maintain control loop stability. The output capacitor requires either an X7R or X5R dielectric. Y5V and Z5U dielectric capacitors, aside from their wide variation in capacitance over temperature, become resistive at high frequencies. There are no additional requirements regarding minimum ESR. Larger capacitors cause lower output voltage ripple as well as lower output voltage drop during load transients but the total output capacitance value should not exceed ca. 50 $\mu$ F.

DC bias effect: high cap. ceramic capacitors exhibit DC bias effects, which have a strong influence on the device's effective capacitance. Therefore the right capacitor value has to be chosen very carefully. Package size and voltage rating in combination with material are responsible for differences between the rated capacitor value and its effective capacitance. For instance, a 10- $\mu$ F X5R 6.3-V 0603 MLCC capacitor would typically show an effective capacitance of less than 4  $\mu$ F (under 5 V bias condition, high temperature).

In applications featuring high pulsed load currents, it is recommended to run the converter with a reasonable amount of effective output capacitance, for instance x2 10- $\mu$ F X5R 6.3-V 0603 MLCC capacitors connected in parallel.

### 10.2.2.3 Input Capacitor

Multilayer ceramic capacitors are an excellent choice for input decoupling of the step-up converter as they have extremely low ESR and are available in small footprints. Input capacitors should be located as close as possible to the device. While a 4.7- $\mu$ F input capacitor is sufficient for most applications, larger values may be used to reduce input current ripple without limitations.

Take care when using only ceramic input capacitors. When a ceramic capacitor is used at the input and the power is being supplied through long wires, such as from a wall adapter, a load step at the output can induce ringing at the VIN pin. This ringing can couple to the output and be mistaken as loop instability or could even damage the part. Additional "bulk" capacitance (electrolytic or tantalum) should in this circumstance be placed between C<sub>I</sub> and the power source lead to reduce ringing that can occur between the inductance of the power source leads and C<sub>I</sub>.

### 10.2.2.4 Checking Loop Stability

The first step of circuit and stability evaluation is to look from a steady-state perspective at the following signals:

- Switching node, SW
- Inductor current, I<sub>L</sub>
- Output ripple voltage, V<sub>OUT(AC)</sub>

These are the basic signals that need to be measured when evaluating a switching converter. When the switching waveform shows large duty cycle jitter or the output voltage or inductor current shows oscillations, the regulation loop may be unstable. This is often a result of board layout and/or L-C combination.

As a next step in the evaluation of the regulation loop, the load transient response is tested. The time between the application of the load transient and the turn on of the P-channel MOSFET, the output capacitor must supply all of the current required by the load. V<sub>OUT</sub> immediately shifts by an amount equal to  $\Delta I_{(LOAD)} \times ESR$ , where ESR is the effective series resistance of C<sub>OUT</sub>.  $\Delta I_{(LOAD)}$  begins to charge or discharge C<sub>OUT</sub> generating a feedback error signal used by the regulator to return V<sub>OUT</sub> to its steady-state value. The results are most easily interpreted when the device operates in PWM mode.

During this recovery time, V<sub>OUT</sub> can be monitored for settling time, overshoot or ringing that helps judge the converter's stability. Without any ringing, the loop has usually more than 45° of phase margin. Because the damping factor of the circuitry is directly related to several resistive parameters (e.g., MOSFET r<sub>DS(on)</sub>) that are temperature dependant, the loop stability analysis has to be done over the input voltage range, load current range, and temperature range.

### 10.2.3 Application Curves

	FIGURE
PFM operation	Figure 11
PWM operation	Figure 12
Combined line/load transient response	Figure 13
Load transient response	Figure 14, Figure 16
AC load transient response	Figure 15, Figure 17
Start-up	Figure 18, Figure 19

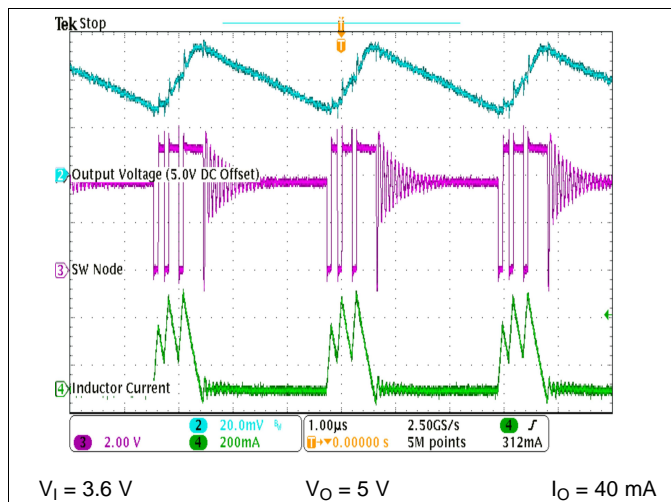

Figure 11. Power-Save Mode Operation

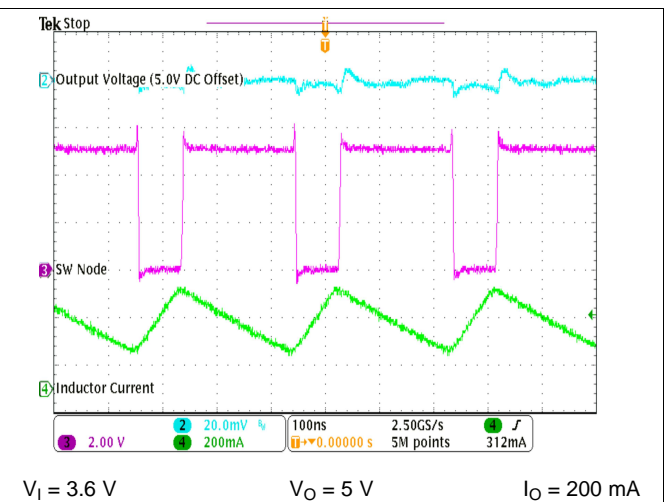

Figure 12. PWM Operation

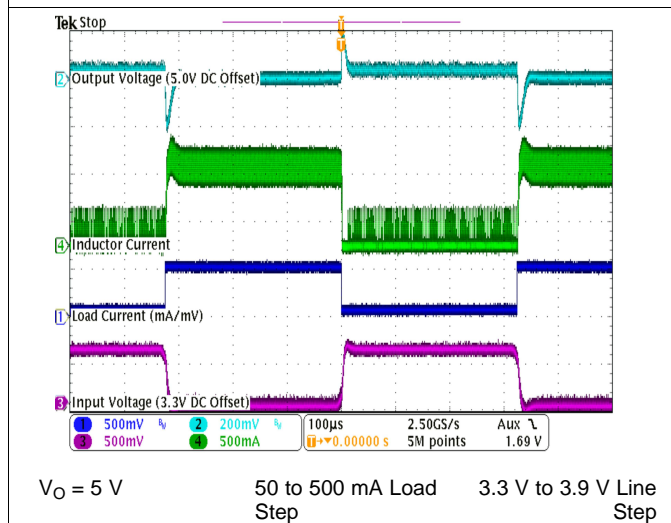

Figure 13. Combined Line/Load Transient Response

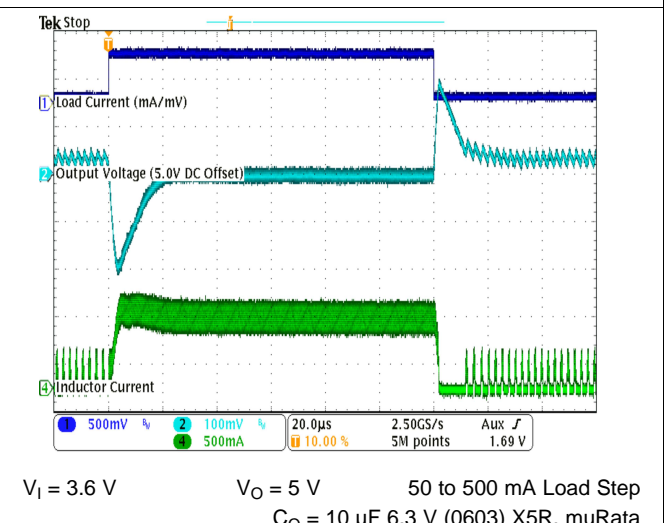
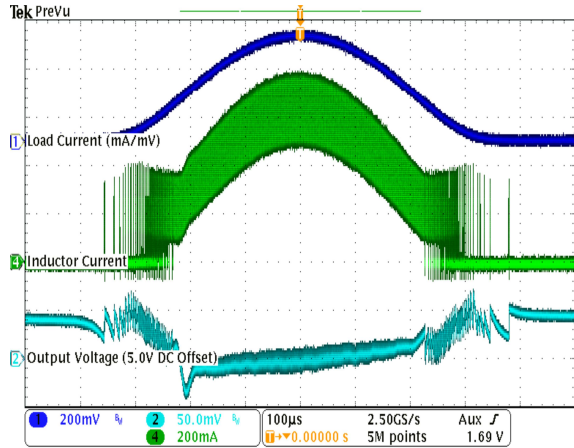
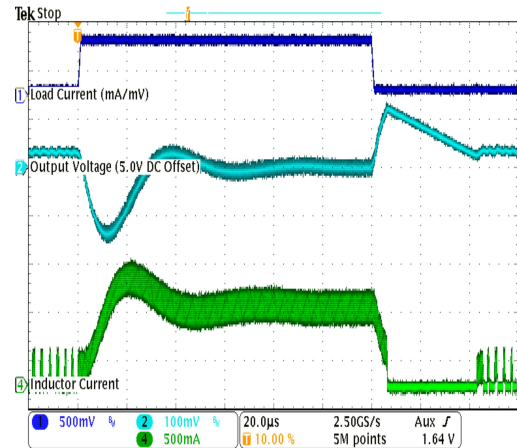

Figure 14. Load Transient Response in PFM/PWM Operation



$V_I = 3.6\text{ V}$        $V_O = 5\text{ V}$       0 to 400 mA Load  
 $C_O = 10\text{ }\mu\text{F } 6.3\text{ V (0603) X5R, muRata}$

Figure 15. AC Load Transient Response



$V_I = 3.6\text{ V}$        $V_O = 5\text{ V}$       50 to 500 mA Load Step  
 $C_O = 22\text{ }\mu\text{F } 10\text{ V (1210) X5R, muRata}$

Figure 16. Load Transient Response in PFM/PWM Operation

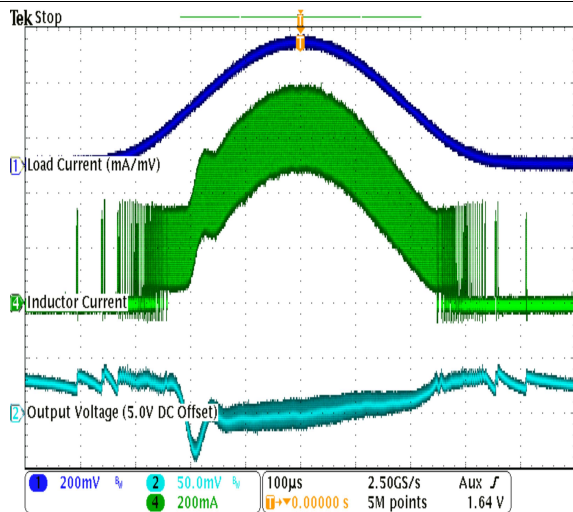

$V_I = 3.6\text{ V}$        $V_O = 5\text{ V}$       0 to 400 mA Load  
 $C_O = 22\text{ }\mu\text{F } 10\text{ V (1210) X5R, muRata}$

Figure 17. AC Load Transient Response

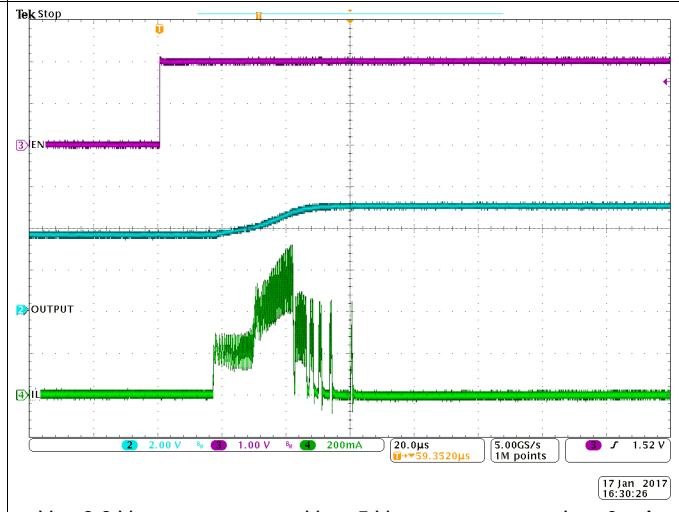

$V_I = 3.6\text{ V}$        $V_O = 5\text{ V}$        $I_O = 0\text{ mA}$

Figure 18. Pass-through to Boost by EN toggling



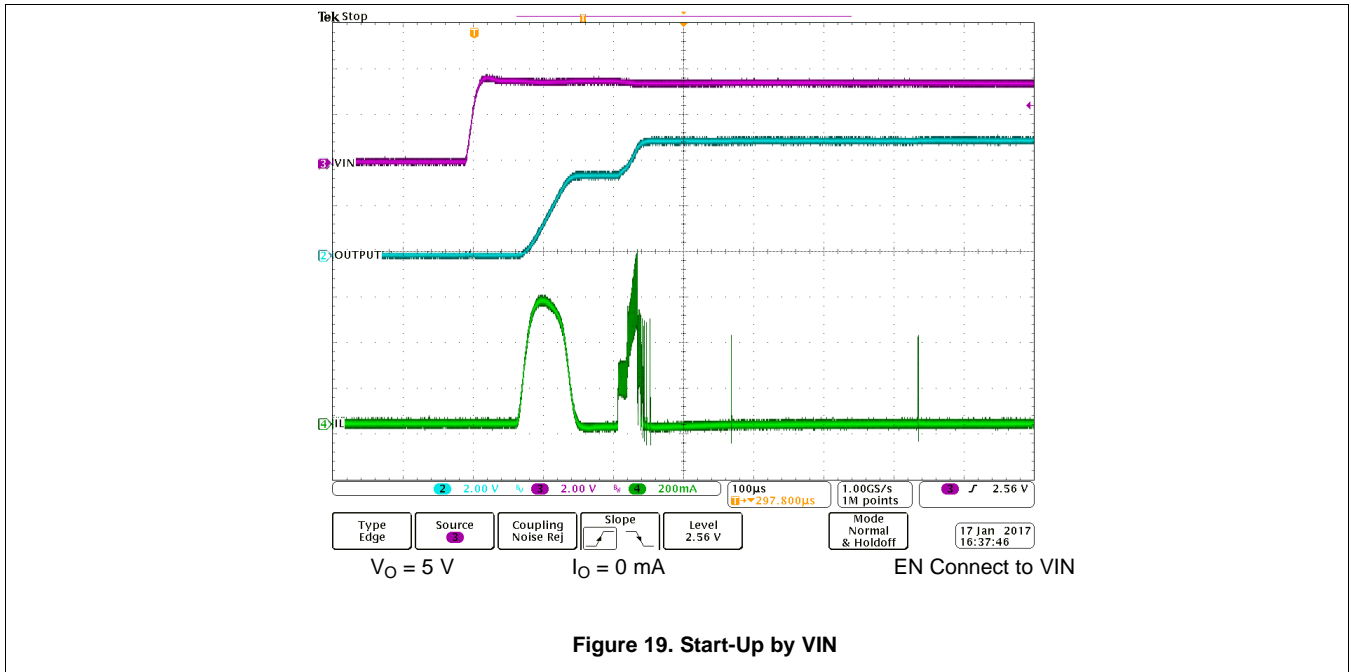

## 11 Power Supply Recommendations

The power supply can be three-cell alkaline, NiCd or NiMH, or one-cell Li-Ion or Li-Polymer battery. The input supply should be well regulated with the rating of TPS61256xC. If the input supply is located more than a few inches from the device, additional bulk capacitance may be required in addition to the ceramic bypass capacitors. An electrolytic or tantalum capacitor with a value of 47  $\mu\text{F}$  is a typical choice.

## 12 Layout

### 12.1 Layout Guidelines

For all switching power supplies, the layout is an important step in the design, especially at high peak currents and high switching frequencies. If the layout is not carefully done, the regulator could show stability problems as well as EMI problems. Therefore, use wide and short traces for the main current path and for the power ground tracks. The input capacitor, output capacitor, and the inductor should be placed as close as possible to the IC. Use a common ground node for power ground and a different one for control ground to minimize the effects of ground noise. Connect these ground nodes at any place close to the ground pins of the IC.

### 12.2 Layout Example

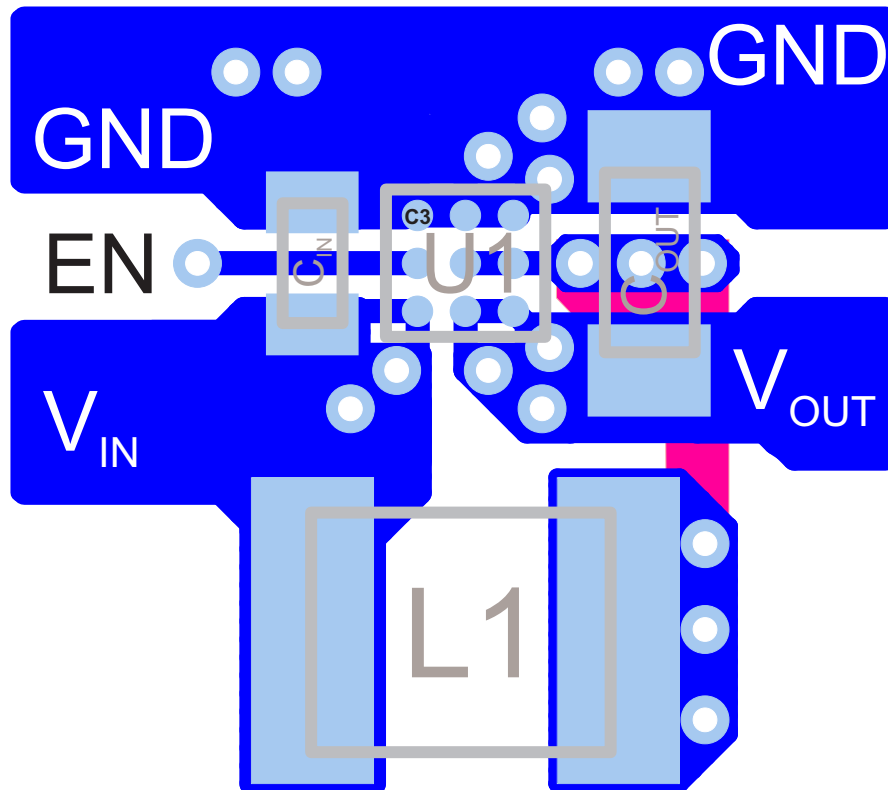

Figure 20. Suggested Layout (Top View)

### 12.3 Thermal Considerations

Implementation of integrated circuits in low-profile and fine-pitch surface-mount packages typically requires special attention to power dissipation. Many system-dependent issues such as thermal coupling, airflow, added heat sinks and convection surfaces, and the presence of other heat-generating components affect the power-dissipation limits of a given component.

Three basic approaches for enhancing thermal performance are listed below:

- Improving the power dissipation capability of the PCB design
- Improving the thermal coupling of the component to the PCB
- Introducing airflow in the system

As power demand in portable designs is more and more important, designers must figure the best trade-off between efficiency, power dissipation and solution size. Due to integration and miniaturization, junction temperature can increase significantly which could lead to bad application behaviors (i.e. premature thermal shutdown or worst case reduce device reliability).

Junction-to-ambient thermal resistance is highly application and board-layout dependent. In applications where the high maximum power dissipation exists, special care must be paid to thermal dissipation issues in board design. The device operating junction temperature ( $T_J$ ) should be kept below 125°C.

## 13 器件和文档支持

### 13.1 器件支持

#### 13.1.1 Third-Party Products Disclaimer

TI'S PUBLICATION OF INFORMATION REGARDING THIRD-PARTY PRODUCTS OR SERVICES DOES NOT CONSTITUTE AN ENDORSEMENT REGARDING THE SUITABILITY OF SUCH PRODUCTS OR SERVICES OR A WARRANTY, REPRESENTATION OR ENDORSEMENT OF SUCH PRODUCTS OR SERVICES, EITHER ALONE OR IN COMBINATION WITH ANY TI PRODUCT OR SERVICE.

### 13.2 接收文档更新通知

要接收文档更新通知，请导航至 [TI.com](http://TI.com) 上的器件产品文件夹。请单击右上角的 [通知我](#) 进行注册，即可收到任意产品信息更改每周摘要。有关更改的详细信息，请查看任意已修订文档中包含的修订历史记录。

### 13.3 社区资源

下列链接提供到 TI 社区资源的连接。链接的内容由各个分销商“按照原样”提供。这些内容并不构成 TI 技术规范，并且不一定反映 TI 的观点；请参阅 TI 的 [《使用条款》](#)。

**TI E2E™ 在线社区** [TI 的工程师对工程师 \(E2E\) 社区](#)。此社区的创建目的在于促进工程师之间的协作。在 [e2e.ti.com](http://e2e.ti.com) 中，您可以咨询问题、分享知识、拓展思路并与同行工程师一道帮助解决问题。

**设计支持** [TI 参考设计支持](#) 可帮助您快速查找有帮助的 E2E 论坛、设计支持工具以及技术支持的联系信息。

### 13.4 商标

NanoFree, E2E are trademarks of Texas Instruments.  
All other trademarks are the property of their respective owners.

### 13.5 静电放电警告



这些装置包含有限的内置 ESD 保护。存储或装卸时，应将导线一起截短或将装置放置于导电泡棉中，以防止 MOS 门极遭受静电损伤。

### 13.6 Glossary

[SLYZ022](#) — *TI Glossary*.

This glossary lists and explains terms, acronyms, and definitions.

## 14 机械、封装和可订购信息

以下页面包括机械、封装和可订购信息。这些信息是指定器件的最新可用数据。这些数据发生变化时，我们可能不会另行通知或修订此文档。如欲获取此产品说明书的浏览器版本，请参见左侧的导航栏。

### 14.1 封装概要

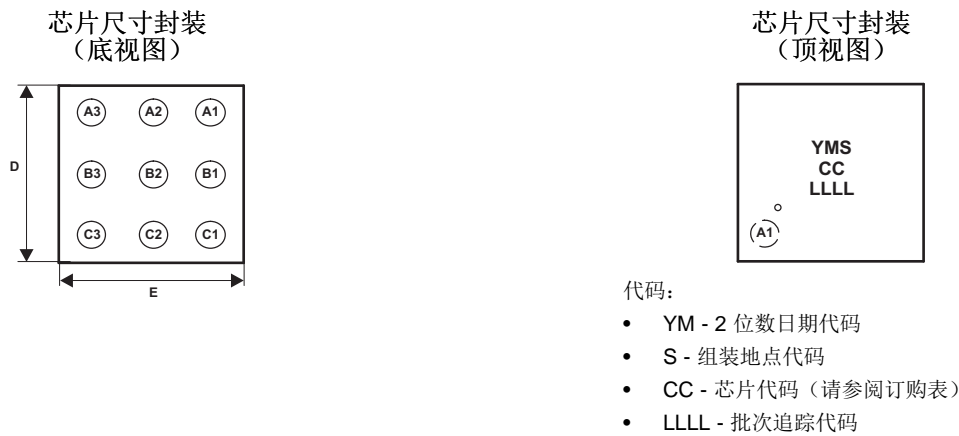

## 14.2 Package Option Addendum

### 14.2.1 Packaging Information

Orderable Device	Status <sup>(1)</sup>	Package Type	Package Drawing	Pins	Package Qty	Eco Plan <sup>(2)</sup>	Lead/Ball Finish <sup>(3)</sup>	MSL Peak Temp <sup>(4)</sup>	Op Temp (°C)	Device Marking <sup>(5)(6)</sup>
TPS612562CYFFR	PREVIEW	DSBGA	YFF	9	3000	Green (RoHS and no Sb/Br)	SNAGCU	Level-1-260C-UNLIM	-40 to 85	16H
TPS612562CYFFT	PREVIEW	DSBGA	YFF	9	250	Green (RoHS and no Sb/Br)	SNAGCU	Level-1-260C-UNLIM	-40 to 85	16H
TPS612564CYFFR	PREVIEW	DSBGA	YFF	9	3000	Green (RoHS and no Sb/Br)	SNAGCU	Level-1-260C-UNLIM	-40 to 85	16I
TPS612564CYFFT	PREVIEW	DSBGA	YFF	9	250	Green (RoHS and no Sb/Br)	SNAGCU	Level-1-260C-UNLIM	-40 to 85	16I

- (1) The marketing status values are defined as follows:  
**ACTIVE:** Product device recommended for new designs.  
**LIFEBUY:** TI has announced that the device will be discontinued, and a lifetime-buy period is in effect.  
**NRND:** Not recommended for new designs. Device is in production to support existing customers, but TI does not recommend using this part in a new design.  
**PRE\_PROD** Unannounced device, not in production, not available for mass market, nor on the web, samples not available.  
**PREVIEW:** Device has been announced but is not in production. Samples may or may not be available.  
**OBSOLETE:** TI has discontinued the production of the device.
- (2) Eco Plan - The planned eco-friendly classification: Pb-Free (RoHS), Pb-Free (RoHS Exempt), or Green (RoHS & no Sb/Br) - please check <http://www.ti.com/productcontent> for the latest availability information and additional product content details.  
**TBD:** The Pb-Free/Green conversion plan has not been defined.  
**Pb-Free (RoHS):** TI's terms "Lead-Free" or "Pb-Free" mean semiconductor products that are compatible with the current RoHS requirements for all 6 substances, including the requirement that lead not exceed 0.1% by weight in homogeneous materials. Where designed to be soldered at high temperatures, TI Pb-Free products are suitable for use in specified lead-free processes.  
**Pb-Free (RoHS Exempt):** This component has a RoHS exemption for either 1) lead-based flip-chip solder bumps used between the die and package, or 2) lead-based die adhesive used between the die and leadframe. The component is otherwise considered Pb-Free (RoHS compatible) as defined above.  
**Green (RoHS & no Sb/Br):** TI defines "Green" to mean Pb-Free (RoHS compatible), and free of Bromine (Br) and Antimony (Sb) based flame retardants (Br or Sb do not exceed 0.1% by weight in homogeneous material)
- (3) Lead/Ball Finish - Orderable Devices may have multiple material finish options. Finish options are separated by a vertical ruled line. Lead/Ball Finish values may wrap to two lines if the finish value exceeds the maximum column width.
- (4) MSL, Peak Temp. -- The Moisture Sensitivity Level rating according to the JEDEC industry standard classifications, and peak solder temperature.
- (5) There may be additional marking, which relates to the logo, the lot trace code information, or the environmental category on the device
- (6) Multiple Device markings will be inside parentheses. Only on Device Marking contained in parentheses and separated by a "~" will appear on a device. If a line is indented then it is a continuation of the previous line and the two combined represent the entire Device Marking for that device.

**Important Information and Disclaimer:** The information provided on this page represents TI's knowledge and belief as of the date that it is provided. TI bases its knowledge and belief on information provided by third parties, and makes no representation or warranty as to the accuracy of such information. Efforts are underway to better integrate information from third parties. TI has taken and continues to take reasonable steps to provide representative and accurate information but may not have conducted destructive testing or chemical analysis on incoming materials and chemicals. TI and TI suppliers consider certain information to be proprietary, and thus CAS numbers and other limited information may not be available for release.

In no event shall TI's liability arising out of such information exceed the total purchase price of the TI part(s) at issue in this document sold by TI to Customer on an annual basis.

Orderable Device	Status <sup>(1)</sup>	Package Type	Package Drawing	Pins	Package Qty	Eco Plan <sup>(2)</sup>	Lead/Ball Finish <sup>(3)</sup>	MSL Peak Temp <sup>(4)</sup>	Op Temp (°C)	Device Marking <sup>(5)(6)</sup>
TPS61256CYFFR	ACTIVE	DSBGA	YFF	9	3000	Green (RoHS and no Sb/Br)	SNAGCU	Level-1-260C-UNLIM	-40 to 85	15U
TPS61256CYFFT	ACTIVE	DSBGA	YFF	9	250	Green (RoHS and no Sb/Br)	SNAGCU	Level-1-260C-UNLIM	-40 to 85	15U

- (1) The marketing status values are defined as follows:  
**ACTIVE:** Product device recommended for new designs.  
**LIFEBUY:** TI has announced that the device will be discontinued, and a lifetime-buy period is in effect.  
**NRND:** Not recommended for new designs. Device is in production to support existing customers, but TI does not recommend using this part in a new design.  
**PRE\_PROD** Unannounced device, not in production, not available for mass market, nor on the web, samples not available.  
**PREVIEW:** Device has been announced but is not in production. Samples may or may not be available.  
**OBSOLETE:** TI has discontinued the production of the device.
- (2) Eco Plan - The planned eco-friendly classification: Pb-Free (RoHS), Pb-Free (RoHS Exempt), or Green (RoHS & no Sb/Br) - please check <http://www.ti.com/productcontent> for the latest availability information and additional product content details.  
**TBD:** The Pb-Free/Green conversion plan has not been defined.  
**Pb-Free (RoHS):** TI's terms "Lead-Free" or "Pb-Free" mean semiconductor products that are compatible with the current RoHS requirements for all 6 substances, including the requirement that lead not exceed 0.1% by weight in homogeneous materials. Where designed to be soldered at high temperatures, TI Pb-Free products are suitable for use in specified lead-free processes.  
**Pb-Free (RoHS Exempt):** This component has a RoHS exemption for either 1) lead-based flip-chip solder bumps used between the die and package, or 2) lead-based die adhesive used between the die and leadframe. The component is otherwise considered Pb-Free (RoHS compatible) as defined above.  
**Green (RoHS & no Sb/Br):** TI defines "Green" to mean Pb-Free (RoHS compatible), and free of Bromine (Br) and Antimony (Sb) based flame retardants (Br or Sb do not exceed 0.1% by weight in homogeneous material)
- (3) Lead/Ball Finish - Orderable Devices may have multiple material finish options. Finish options are separated by a vertical ruled line. Lead/Ball Finish values may wrap to two lines if the finish value exceeds the maximum column width.
- (4) MSL, Peak Temp. -- The Moisture Sensitivity Level rating according to the JEDEC industry standard classifications, and peak solder temperature.
- (5) There may be additional marking, which relates to the logo, the lot trace code information, or the environmental category on the device
- (6) Multiple Device markings will be inside parentheses. Only on Device Marking contained in parentheses and separated by a "-" will appear on a device. If a line is indented then it is a continuation of the previous line and the two combined represent the entire Device Marking for that device.

**Important Information and Disclaimer:** The information provided on this page represents TI's knowledge and belief as of the date that it is provided. TI bases its knowledge and belief on information provided by third parties, and makes no representation or warranty as to the accuracy of such information. Efforts are underway to better integrate information from third parties. TI has taken and continues to take reasonable steps to provide representative and accurate information but may not have conducted destructive testing or chemical analysis on incoming materials and chemicals. TI and TI suppliers consider certain information to be proprietary, and thus CAS numbers and other limited information may not be available for release.

In no event shall TI's liability arising out of such information exceed the total purchase price of the TI part(s) at issue in this document sold by TI to Customer on an annual basis.

# TPS61256C

ZHCSG06A – FEBRUARY 2017 – REVISED JUNE 2017

www.ti.com.cn

## 14.2.2 Tape and Reel Information

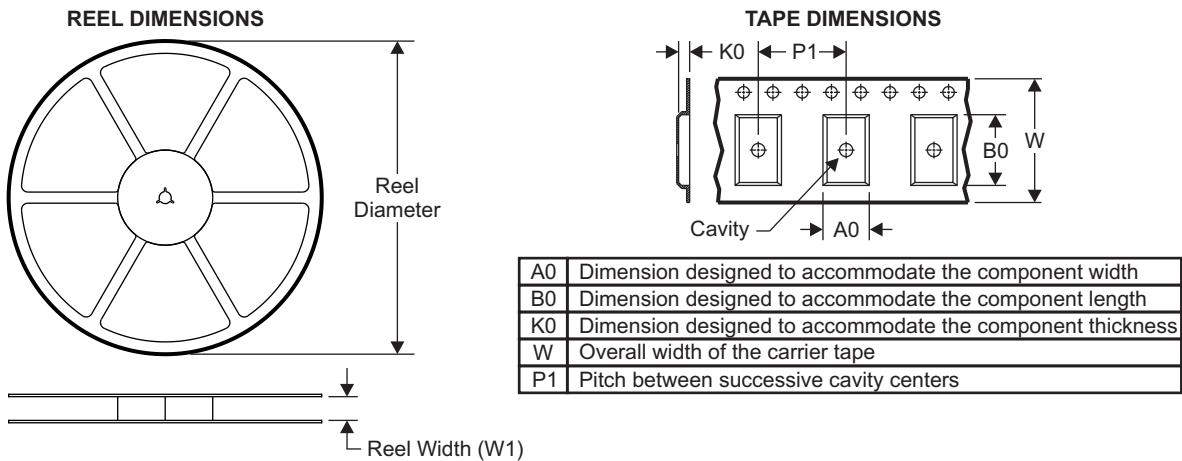

### QUADRANT ASSIGNMENTS FOR PIN 1 ORIENTATION IN TAPE

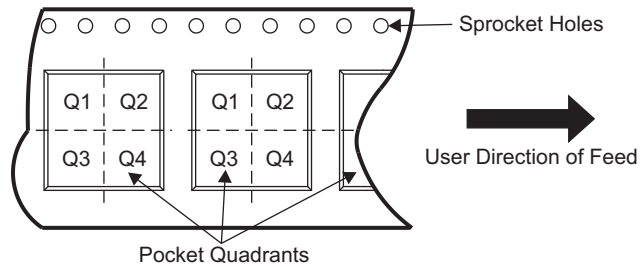

Device	Package Type	Package Drawing	Pins	SPQ	Reel Diameter (mm)	Reel Width W1 (mm)	A0 (mm)	B0 (mm)	K0 (mm)	P1 (mm)	W (mm)	Pin1 Quadrant
TPS612562CYFFR	DSBGA	YFF	9	3000	180.0	8.4	1.41	1.31	0.69	2.0	8.0	Q1
TPS612562CYFFT	DSBGA	YFF	9	250	180.0	8.4	1.41	1.31	0.69	2.0	8.0	Q1
TPS612564CYFFR	DSBGA	YFF	9	3000	180.0	8.4	1.41	1.31	0.69	2.0	8.0	Q1
TPS612564CYFFT	DSBGA	YFF	9	250	180.0	8.4	1.41	1.31	0.69	2.0	8.0	Q1
TPS61256CYFFR	DSBGA	YFF	9	3000	180.0	8.4	1.41	1.31	0.69	2.0	8.0	Q1
TPS61256CYFFT	DSBGA	YFF	9	250	180.0	8.4	1.41	1.31	0.69	2.0	8.0	Q1



**TAPE AND REEL BOX DIMENSIONS**

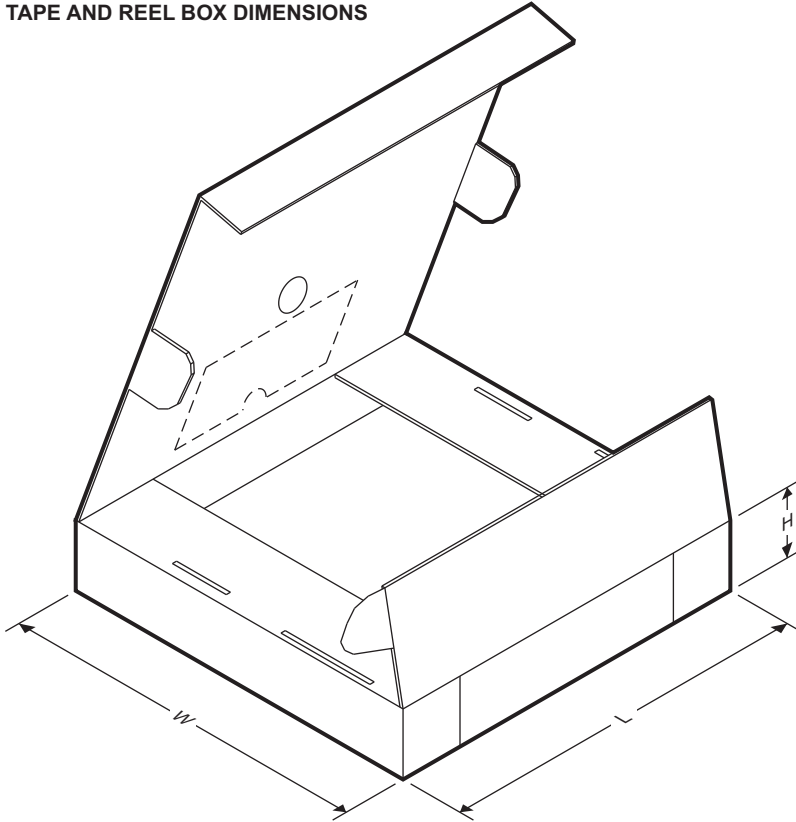

Device	Package Type	Package Drawing	Pins	SPQ	Length (mm)	Width (mm)	Height (mm)
TPS612562CYFFR	DSBGA	YFF	9	3000	182.0	182.0	20.0
TPS612562CYFFT	DSBGA	YFF	9	250	182.0	182.0	20.0
TPS612564CYFFR	DSBGA	YFF	9	3000	182.0	182.0	20.0
TPS612564CYFFT	DSBGA	YFF	9	250	182.0	182.0	20.0
TPS61256CYFFR	DSBGA	YFF	9	3000	182.0	182.0	20.0
TPS61256CYFFT	DSBGA	YFF	9	250	182.0	182.0	20.0

YFF0009

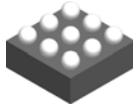

# PACKAGE OUTLINE

DSBGA - 0.625 mm max height

DIE SIZE BALL GRID ARRAY

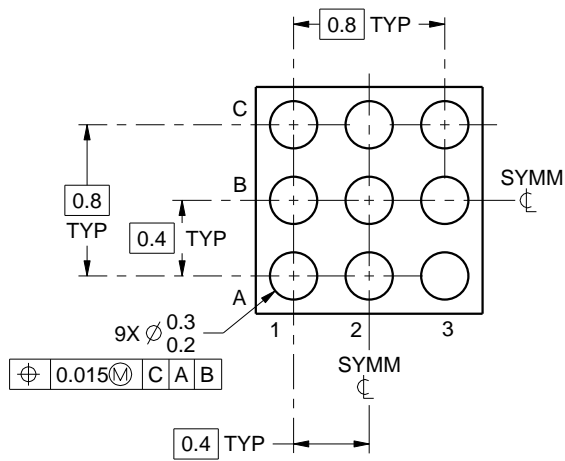
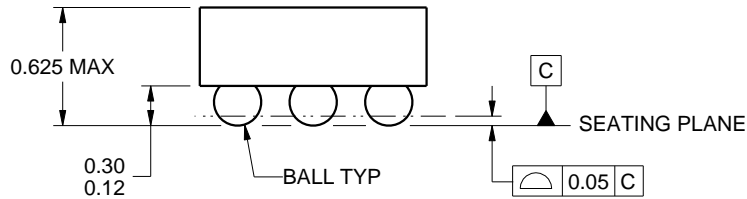
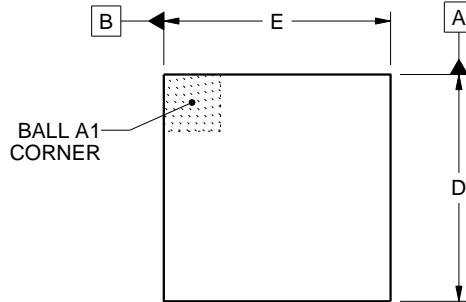

D: Max = 1.336 mm, Min = 1.276 mm  
E: Max = 1.236 mm, Min = 1.176 mm

4219552/A 05/2016

NOTES:

1. All linear dimensions are in millimeters. Any dimensions in parenthesis are for reference only. Dimensioning and tolerancing per ASME Y14.5M.
2. This drawing is subject to change without notice.

# EXAMPLE BOARD LAYOUT

YFF0009

DSBGA - 0.625 mm max height

DIE SIZE BALL GRID ARRAY

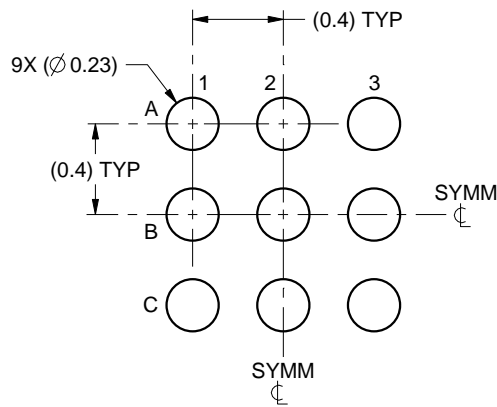

LAND PATTERN EXAMPLE  
SCALE:30X

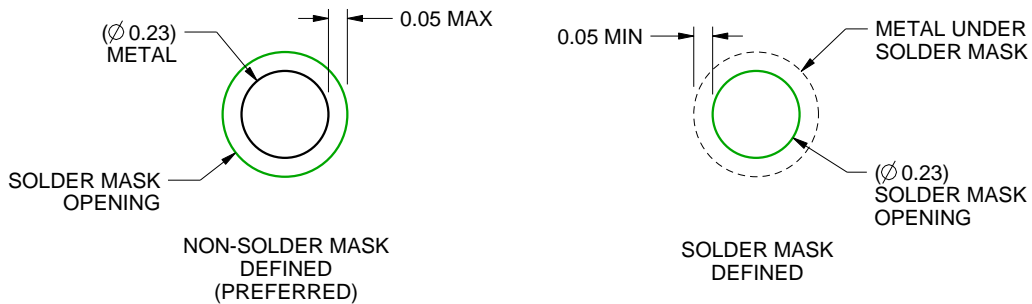

SOLDER MASK DETAILS  
NOT TO SCALE

4219552/A 05/2016

NOTES: (continued)

3. Final dimensions may vary due to manufacturing tolerance considerations and also routing constraints. For more information, see Texas Instruments literature number SNVA009 ([www.ti.com/lit/snva009](http://www.ti.com/lit/snva009)).

# EXAMPLE STENCIL DESIGN

YFF0009

DSBGA - 0.625 mm max height

DIE SIZE BALL GRID ARRAY

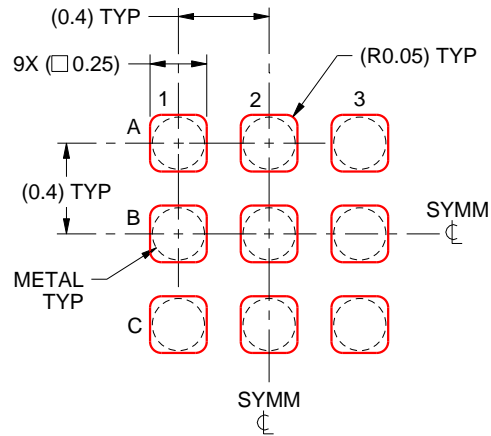

SOLDER PASTE EXAMPLE  
BASED ON 0.1 mm THICK STENCIL  
SCALE:30X

4219552/A 05/2016

NOTES: (continued)

4. Laser cutting apertures with trapezoidal walls and rounded corners may offer better paste release.

## 重要声明和免责声明

TI“按原样”提供技术和可靠性数据（包括数据表）、设计资源（包括参考设计）、应用或其他设计建议、网络工具、安全信息和其他资源，不保证没有瑕疵且不做任何明示或暗示的担保，包括但不限于对适销性、某特定用途方面的适用性或不侵犯任何第三方知识产权的暗示担保。

这些资源可供使用 TI 产品进行设计的熟练开发人员使用。您将自行承担以下全部责任：(1) 针对您的应用选择合适的 TI 产品，(2) 设计、验证并测试您的应用，(3) 确保您的应用满足相应标准以及任何其他功能安全、信息安全、监管或其他要求。

这些资源如有变更，恕不另行通知。TI 授权您仅可将这些资源用于研发本资源所述的 TI 产品的应用。严禁对这些资源进行其他复制或展示。您无权使用任何其他 TI 知识产权或任何第三方知识产权。您应全额赔偿因在这些资源的使用中对 TI 及其代表造成的任何索赔、损害、成本、损失和债务，TI 对此概不负责。

TI 提供的产品受 [TI 的销售条款](#) 或 [ti.com](#) 上其他适用条款/TI 产品随附的其他适用条款的约束。TI 提供这些资源并不会扩展或以其他方式更改 TI 针对 TI 产品发布的适用的担保或担保免责声明。

TI 反对并拒绝您可能提出的任何其他或不同的条款。

邮寄地址：Texas Instruments, Post Office Box 655303, Dallas, Texas 75265

Copyright © 2023，德州仪器 (TI) 公司