

TPS62184 4V 至 17V、6A、双相降压转换器，具有 AEE™

1 特性

- 双相平衡峰值电流模式
- 输入电压范围：4V 至 17V
- 输出电压：
 - $0.9V \leq V_{OUT} \leq 1.8V$ (6A),
 - $1.8V \leq V_{OUT} \leq 2.5V$ (5.5A)
 - $2.5V \leq V_{OUT} \leq 3.5V$ (5A)
- 典型静态电流为 28 μ A
- 输出电压精度达 $\pm 1\%$ (脉宽调制 (PWM) 模式)
- 自动效率提高 (AEE™)
- 相移操作
- 自动节能模式
- 可调软启动
- 电源正常输出
- 欠压闭锁
- HICCUP 过流保护
- 过热保护
- 与 TPS62180/2 引脚到引脚兼容
- NanoFree™ 2.10mm x 3.10mm 芯片尺寸球状引脚栅格阵列 (DSBGA) 封装

2 应用

- 薄型负载点 (POL) 电源
- 窄 VDC (NVDC) 供电系统
- 两/三节锂离子电池
- 超便携式/嵌入式/平板电脑
- 计算网络解决方案
- 微型服务器和固态硬盘 (SSD)

4 简化电路原理图

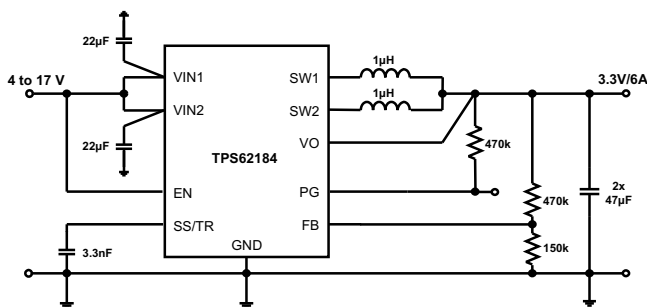

3 说明

TPS62184 是一款适用于薄型电源轨的双相降压 DC-DC 转换器。它通过使用两个由峰值电流控制的相同电流平衡相位来进行工作，适合在高度受限的应用中使用。

该器件具有 4V 到 17V 的宽工作输入电压范围，非常适合通过多节锂离子电池或 12V 电源轨供电运行的系统。两相可持续提供 6A 输出电流（每相 3A），从而允许使用薄型外部元件。两相异相运行，这样可显著减小开关噪声。

TPS62184 可在超轻负载时自动进入节能模式以保持高效率。并且还集成有自动效率提高功能 (AEE™)，适用于整个占空比范围。

该器件提供电源正常信号和可调节软启动。其静态电流典型值为 28 μ A，并且能够在 100% 模式下运行，即使在最低输出电压下也不存在占空比限制。

TPS62184 采用小型 24 凸点、0.5mm 间距 DSBGA 封装。

器件信息(1)

器件型号	封装	封装尺寸 (标称值)
TPS62184	DSBGA (24)	2.10mm x 3.10mm

(1) 如需了解所有可用封装，请见数据表末尾的可订购产品附录。

效率与输出电流间的关系

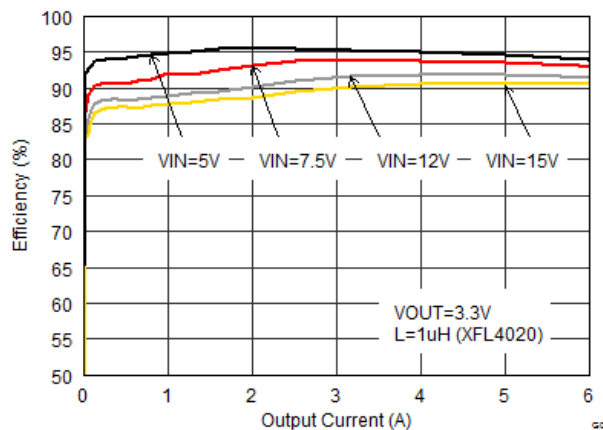

目录

1	特性	1	8.3	Feature Description	8
2	应用	1	8.4	Device Functional Modes	8
3	说明	1	9	Application and Implementation	13
4	简化电路原理图	1	9.1	Application Information	13
5	修订历史记录	2	9.2	Typical Applications	13
6	Pin Configuration and Functions	3	9.3	System Examples	22
7	Specifications	4	10	Power Supply Recommendations	24
7.1	Absolute Maximum Ratings	4	11	Layout	25
7.2	ESD Ratings	4	11.1	Layout Guidelines	25
7.3	Recommended Operating Conditions	4	11.2	Layout Example	25
7.4	Thermal Information	4	12	器件和文档支持	26
7.5	Electrical Characteristics	5	12.1	器件支持	26
7.6	Typical Characteristics	6	12.2	商标	26
8	Detailed Description	7	12.3	静电放电警告	26
8.1	Overview	7	12.4	术语表	26
8.2	Functional Block Diagram	7	13	机械封装和可订购信息	26

5 修订历史记录

Changes from Original (December 2014) to Revision A

Page

- Published full Production Data sheet to include *Specification* tables, *Feature Description* section, *Device Functional Modes*, *Application and Implementation* section, *Power Supply Recommendations* section, *Layout* section, *Device and Documentation Support* section, and *Mechanical, Packaging, and Orderable Information* section **4**

6 Pin Configuration and Functions

24-Pin DSBGA
YZF Package
(Top View - Left, Bottom View - Right)

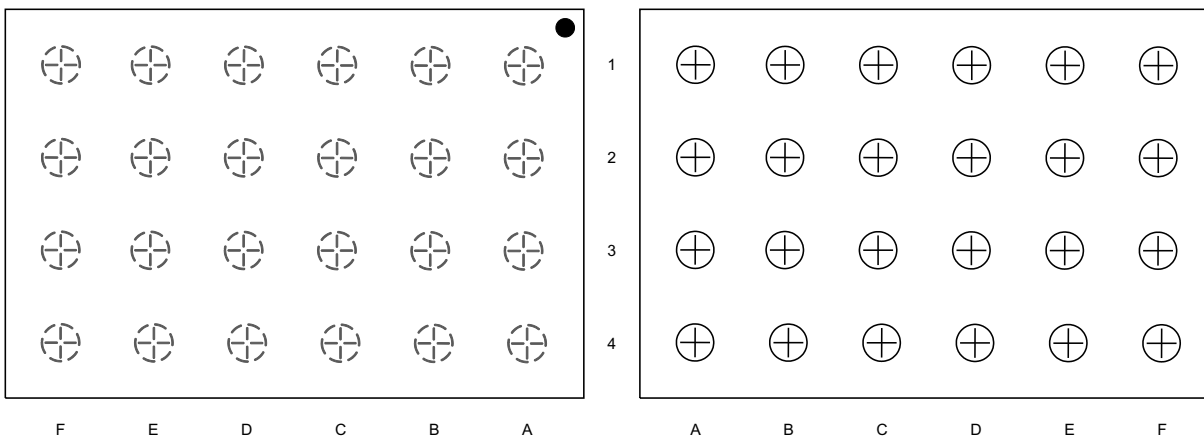

Pin Functions

PIN ⁽¹⁾		DESCRIPTION
NAME	NUMBER	
AGND	C4	Analog Ground. Connect on PCB directly with PGND.
EN	E4	Enable input (High = enabled, Low = disabled)
FB	B4	Output voltage feedback. Connect resistive voltage divider to this pin and AGND. On TPS62182, connect to AGND.
PG	F4	Output power good (High = VOUT ready, Low = VOUT below nominal regulation); open drain (requires pull-up resistor)
PGND	A3, B3, C3, D3, E3, F3	Common power ground.
SS/TR	D4	Soft-Start and Tracking Pin. An external capacitor connected to this pin sets the internal voltage reference rise time.
SW1	A2, B2, C2	Switch node for Phase 1 (master), connected to the internal MOSFET switches. Connect inductor 1 between SW1 and output capacitor.
SW2	D2, E2, F2	Switch node for Phase 2 (follower), connected to the internal MOSFET switches. Connect inductor 2 between SW2 and output capacitor.
VIN1	A1, B1, C1	Supply voltage for Phase 1.
VIN2	D1, E1, F1	Supply voltage for Phase 2.
VO	A4	Output Voltage Connection

(1) For more information about connecting pins, see [Detailed Description](#) and [Application Information](#) sections.

7 Specifications

7.1 Absolute Maximum Ratings⁽¹⁾

Over operating junction temperature range (unless otherwise noted)

		MIN	MAX	UNIT
Pin voltage range ⁽²⁾	VIN1, VIN2	-0.3	20	V
	EN, PG, SW1, SW2	-0.3	$V_{IN} + 0.3$	V
	SS/TR	-0.3	$V_{IN} + 0.3$, but ≤ 7	V
	FB, VO	-0.3	7	V
Power good sink current	PG		10	mA
Operating junction temperature, T_J		-40	150	°C
Storage temperature, T_{stg}		-65	150	°C

- (1) Stresses beyond those listed under *Absolute Maximum Ratings* may cause permanent damage to the device. These are stress ratings only, which do not imply functional operation of the device at these or any other conditions beyond those indicated under *Recommended Operating Conditions*. Exposure to absolute-maximum-rated conditions for extended periods may affect device reliability.
- (2) All voltages are with respect to network ground pin.

7.2 ESD Ratings

		VALUE	UNIT
V_{ESD} ⁽¹⁾	Human Body Model (HBM) ESD stress voltage ⁽²⁾	±1000	V
	Charge device model (CDM) ESD stress voltage	±500	

- (1) Electrostatic discharge (ESD) to measure device sensitivity and immunity to damage caused by assembly line electrostatic discharges in to the device.
- (2) Level listed above is the passing level per ANSI, ESDA, and JEDEC JS-001. JEDEC document JEP155 states that 500-V HBM allows safe manufacturing with a standard ESD control process.

7.3 Recommended Operating Conditions

Over operating junction temperature range (unless otherwise noted)

		MIN	TYP	MAX	UNIT
Supply voltage range, V_{IN}		4		17	V
Output voltage range, V_{OUT}		0.9		3.5	V
Maximum Output current, $I_{OUT(max)}$	$0.9V \leq V_{OUT} \leq 1.8V$	6			A
	$1.8V \leq V_{OUT} \leq 2.5V$	5.5			A
	$2.5V \leq V_{OUT} \leq 3.5V$	5			A
Operating junction temperature, T_J		-40		125	°C

7.4 Thermal Information

THERMAL METRIC ⁽¹⁾		TPS62184	UNIT
		YZF (24 PINS)	
$R_{\theta JA}$	Junction-to-ambient thermal resistance	61.5	°C/W
$R_{\theta Jctop}$	Junction-to-case (top) thermal resistance	0.3	
$R_{\theta JB}$	Junction-to-board thermal resistance	10.1	
Ψ_{JT}	Junction-to-top characterization parameter	0.1	
Ψ_{JB}	Junction-to-board characterization parameter	10.1	
$R_{\theta Jcbot}$	Junction-to-case (bottom) thermal resistance	n/a	

- (1) For more information about traditional and new thermal metrics, see the *IC Package Thermal Metrics* application report, [SPRA953](#).

7.5 Electrical Characteristics

Over operating junction temperature range ($T_J = -40^\circ\text{C}$ to $+125^\circ\text{C}$) and $V_{IN} = 4\text{ V}$ to 17 V .
Typical values at $V_{IN} = 12\text{ V}$ and $T_J = 25^\circ\text{C}$ (unless otherwise noted).

PARAMETER		TEST CONDITIONS	MIN	TYP	MAX	UNIT	
SUPPLY							
V_{IN}	Input voltage range		4		17	V	
I_Q	Operating quiescent current	EN = High, $I_{OUT} = 0\text{ mA}$, Device not switching, ($T_J = -40^\circ\text{C}$ to $+85^\circ\text{C}$)		28	55	μA	
I_{SD}	Shutdown current	EN = Low ($\leq 0.3\text{ V}$), ($T_J = -40^\circ\text{C}$ to $+85^\circ\text{C}$)		2.8	15	μA	
V_{UVLO}	Undervoltage lockout threshold ⁽¹⁾	Falling input voltage	3.5	3.6	3.7	V	
		Hysteresis		300		mV	
T_{SD}	Thermal shutdown	Rising junction temperature		160		$^\circ\text{C}$	
		Hysteresis		20			
CONTROL (EN, SS/TR, PG)							
V_{H_EN}	High-level input threshold voltage (EN)		0.97	1	1.03	V	
V_{L_EN}	Low-level input threshold voltage (EN)		0.87	0.9	0.93	V	
I_{LKG_EN}	Input leakage current (EN)	EN = V_{IN} or GND		0.01	1.2	μA	
$I_{SS/TR}$	SS/TR pin source current		4.5	5	5.5	μA	
V_{TH_PG}	Power good threshold voltage	Rising ($\%V_{OUT}$)	94%	96%	98%		
		Falling ($\%V_{OUT}$)	90%	92%	94%		
V_{OL_PG}	Power good output low voltage	$I_{PG} = -2\text{ mA}$			0.3	V	
I_{LKG_PG}	Input leakage current (PG)			1	100	nA	
POWER SWITCH							
$R_{DS(ON)}$	High-side MOSFET ON-resistance	$V_{IN} = 7.5\text{ V}$	Phase 1		27	65	m Ω
			Phase 2				
	Low-side MOSFET ON-resistance		Phase 1		21	45	m Ω
			Phase 2				
I_{LIM}	High-side MOSFET current limit	Each phase, $V_{IN} = 7.5\text{ V}$	3.5	4.2	5.0	A	
T_{PSD}	Phase shift delay time	Phase 2 after Phase 1, PWM mode		250		ns	
OUTPUT							
V_{REF}	Internal reference voltage		0.792	0.8	0.808	V	
I_{LKG_FB}	Input leakage current (FB)	$V_{FB} = 0.8\text{ V}$		1	100	nA	
$R_{DISCHARGE}$	Output discharge resistance	EN = Low		60		Ω	
V_{OUT}	Output voltage range	$V_{IN} \geq V_{OUT}$	0.9		3.5	V	
		PWM Mode, $V_{IN} \geq V_{OUT} + 1\text{ V}$	-1%		1%		
	Feedback voltage accuracy ⁽²⁾	Power Save Mode, $V_{OUT} = 3.3\text{ V}$, $I_{load} \geq 1\text{ mA}$, $L = 1\text{ }\mu\text{H}$, $C_{OUT} = 2 \times 47\text{ }\mu\text{F}$, ($T_J = -40^\circ\text{C}$ to $+85^\circ\text{C}$)	-1%		2%		
		Power Save Mode, $V_{OUT} = 1.8\text{ V}$, $I_{load} \geq 1\text{ mA}$, $L = 1\text{ }\mu\text{H}$, $C_{OUT} = 4 \times 47\text{ }\mu\text{F}$, ($T_J = -40^\circ\text{C}$ to $+85^\circ\text{C}$)	-1%		2%		
		Power Save Mode, $V_{OUT} = 0.9\text{ V}$, $I_{load} \geq 1\text{ mA}$, $L = 1\text{ }\mu\text{H}$, $C_{OUT} = 4 \times 47\text{ }\mu\text{F}$, ($T_J = -40^\circ\text{C}$ to $+85^\circ\text{C}$)	-1%		3%		
	Load regulation	PWM Mode operation		0.06		%/A	
Line regulation	$4\text{ V} \leq V_{IN} \leq 17\text{ V}$, $I_{OUT} = 4\text{ A}$		0.01		%/V		
t_{HICCUP}	Hiccup on time			0.9		ms	
	Hiccup off time			5			

(1) The minimum V_{IN} value of 4 V is not violated by UVLO threshold and hysteresis variations.

(2) The accuracy in Power Save Mode can be improved by increasing the output capacitor value, reducing the output voltage ripple.

7.6 Typical Characteristics

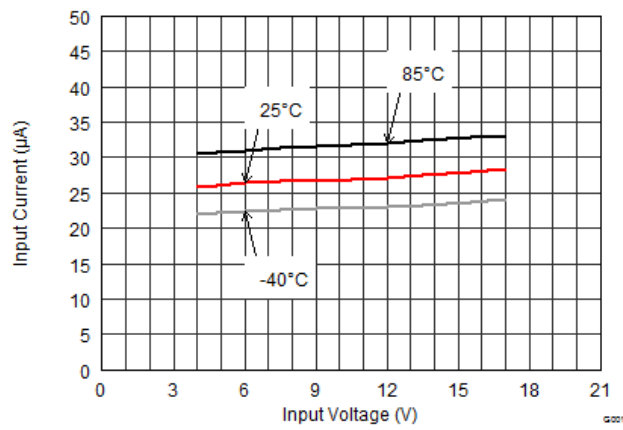

Figure 2. Quiescent Current

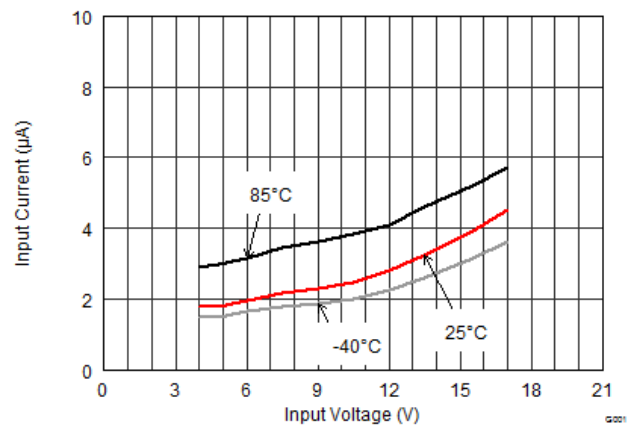

Figure 3. Shutdown Current

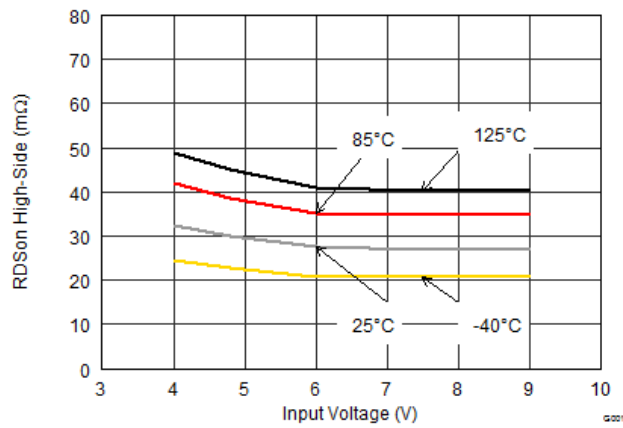

Figure 4. High-Side Switch Resistance

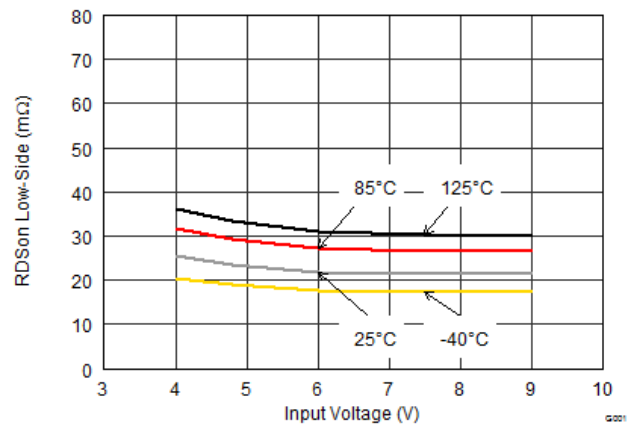

Figure 5. Low-Side Switch Resistance

8 Detailed Description

8.1 Overview

The TPS62184 is a high efficiency synchronous switched mode step-down converter based on a peak current control topology. It is designed for smallest solution size low-profile applications, converting multi-cell Li-Ion supply voltages to output voltages of 0.9 V to 3.5 V. While an outer voltage loop sets the regulation threshold for the current loop based on the actual V_{OUT} level, the inner current loop adapts the peak inductor current for every switching cycle. The regulation network is internally compensated. The switching frequency is set by an OFF-time control and features Power Save Mode (PSM) and Automatic Efficiency Enhancement (AEE™) to keep the efficiency high over the whole load current and duty cycle range. The switching frequency is set depending on V_{IN} and V_{OUT} and remains unchanged for steady state operating conditions.

The TPS62184 is a dual phase converter, sharing the load current among the phases. Identical in construction, the follower control loop is connected with a fixed delay to the master control loop. Both the phases use the same regulation threshold and cycle-by-cycle peak current setpoint. This ensures a phase-shifted as well as current-balanced operation. Using the advantages of the dual phase topology, a 6-A continuous output current is provided with high performance and smallest system solution size.

8.2 Functional Block Diagram

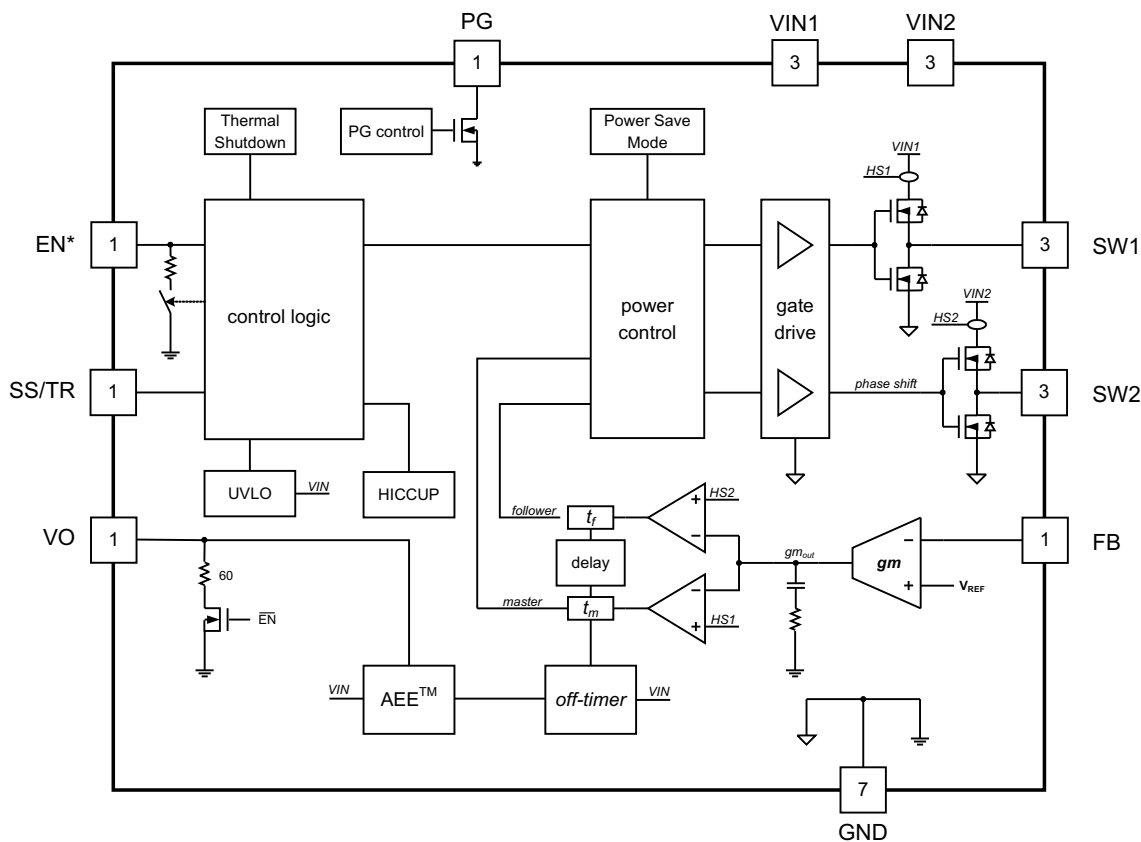

*Pin is connected to a pull down resistor internally
(see Feature Description section)

Figure 6. TPS62184

8.3 Feature Description

8.3.1 Enable / Shutdown (EN)

The device starts operation, when V_{IN} is present and Enable (EN) is set High. The EN threshold is 1 V for rising and 0.9 V for falling voltages, providing a threshold accuracy of $\pm 3\%$. That makes it suitable for precise switching on and off in accurate power sequencing arrangements as well as for slowly rising EN control voltage signals (see [Using the Accurate EN Threshold](#) for more details).

The device is disabled by pulling EN Low. A discharge resistor of about 60 Ω is then connected to the output. At the EN pin, an internal pull down resistor of about 350 k Ω keeps the Low state, if EN gets high impedance or floating afterwards.

The EN pin can be connected to V_{IN} to always enable the device. A delay of 1 ms, after V_{IN} exceeds V_{UVLO} , ensures safe operating conditions before the device starts switching. If V_{IN} is already present, a soft start sequence is initiated about 100 μ s after EN is pulled High.

8.3.2 Soft Start / Tracking (SS/TR)

The soft start circuit controls the output voltage slope during startup. This avoids excessive inrush current and ensures a controlled output voltage rise time. It also prevents unwanted voltage drop from high impedance power sources or batteries. When EN is set to start device operation, the device starts switching and V_{OUT} rises with a slope, controlled by the external capacitor connected to the SS/TR pin. It is not recommended to leave the SS/TR pin floating, because V_{OUT} may overshoot. Typical startup operation is shown in [Application Performance Curves](#).

The device can track an external voltage (see [Tracking](#)). The device can monotonically start into a pre-biased output.

8.3.3 Power Good (PG)

The TPS62184 has a built in power good (PG) function. The PG pin goes High, when the output voltage has reached its nominal value. Otherwise, including when disabled, in UVLO or in thermal shutdown, PG is Low. The PG pin is an open drain output that requires a pull-up resistor and can sink typically 2 mA. If not used, the PG pin can be left floating or grounded.

8.3.4 Undervoltage Lockout (UVLO)

The undervoltage lockout (UVLO) prevents misoperation of the device, if the input voltage drops below the UVLO threshold. It is set to 3.6 V typically with a hysteresis of typically 300mV. (See also [Device Functional Modes](#)).

8.3.5 Thermal Shutdown

The junction temperature T_J of the device is monitored by an internal temperature sensor. If T_J exceeds 160°C (typ.), the device goes in thermal shutdown with a hysteresis of typically 20°C. Both the power FETs are turned off, the discharge resistor is connected to the output and the PG pin goes Low. Once T_J has decreased enough, the device resumes normal operation with Soft Start.

8.4 Device Functional Modes

8.4.1 Pulse Width Modulation (PWM) Operation

The TPS62184 is based on a predictive OFF-time peak current control topology, operating with PWM in continuous conduction mode for heavier loads. Since the OFF-time is automatically adjusted according to the actual V_{IN} and V_{OUT} , it provides highest efficiency over the entire input and output voltage range. The OFF-time is calculated as:

$$t_{OFF} = \left[\frac{V_{IN}}{5V_{OUT}} 500ns \right] + 50ns \quad (1)$$

Device Functional Modes (continued)

While the OFF-time is predicted, the ON-time is set depending on the converter's duty cycle and calculated as:

$$t_{ON} = \frac{t_{OFF} \cdot V_{OUT}}{V_{IN} - V_{OUT}} \quad (2)$$

Thereby the switching frequency is fixed for a given input and output voltage and is calculated as:

$$f_{SW} = \frac{1-D}{t_{OFF}} = \frac{1}{t_{OFF}} \left(1 - \frac{V_{OUT}}{V_{IN}} \right) \quad (3)$$

Both the master and follower phases regulate to the same level of V_{OUT} with separate current loops, using the same peak current setpoint, cycle by cycle. This provides excellent peak current balancing, independent of inductor dc resistance matching. Since the follower phase operates with a fixed delay to the master phase, also cycle by cycle, phase shifted operation is obtained.

The device features an automatic transition into Power Save Mode, entered at light loads, running in discontinuous conduction mode (DCM).

8.4.2 Power Save Mode (PSM) Operation

As the load current decreases, the converter enters Power Save Mode operation. During PSM, the converter operates with a reduced switching frequency maintaining highest efficiency due to minimum quiescent current. Power Save Mode is based on a fixed peak current architecture, where the peak current (I_{PEAK}) is set depending on V_{IN} , V_{OUT} , and L . After each single pulse, a pause time until the internal V_{OUT_Low} level threshold is reached completes the switching cycle in PSM.

The switching frequency for PSM in one phase operation is calculated as :

$$f_{PSM} = \frac{2I_{OUT} \cdot V_{OUT} (V_{IN} - V_{OUT})}{L \cdot I_{PEAK}^2 \cdot V_{IN}} \quad (4)$$

[Equation 4](#) shows the linear relationship of output current and switching frequency. Typical values of the fixed peak current are shown in [Figure 7](#).

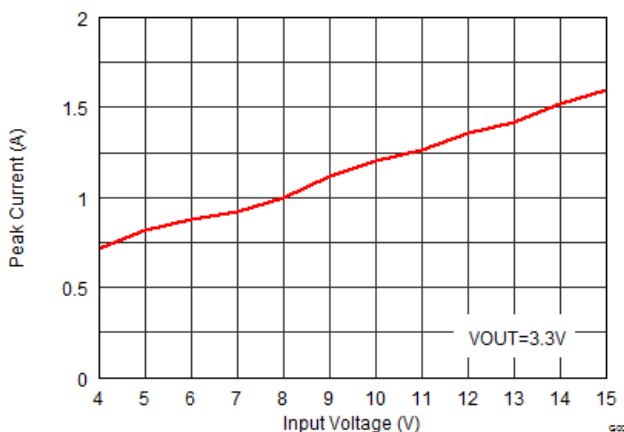
Device Functional Modes (continued)

Figure 7. Typical Fixed Peak Current (I_{PEAK}) in Power Save Mode

If the load decreases to very light loads and only one phase is needed, either phase (master or follower) might be active. The load current level at which Power Save Mode is entered is calculated as follows:

$$I_{load(PSM)} = \Delta I_L \quad (5)$$

Equation 7 is used to calculate ΔI_L .

8.4.3 Minimum Duty Cycle and 100% Mode Operation

When the input voltage comes close to the output voltage, the device enters 100% mode and both high-side FETs are continuously switched on as long as V_{OUT} remains below its setpoint. The minimum V_{IN} to maintain output voltage regulation is calculated as:

$$V_{IN(min)} = V_{OUT(min)} + I_{OUT} \left[\frac{R_{DS(ON)}}{2} + DCR_{L1} // DCR_{L2} \right] \quad (6)$$

This allows the conversion of small input to output voltage differences, for example for longest operation time in battery powered applications. In 100% duty cycle mode, the low-side FET is switched off.

While the maximum ON-time is not limited, the AEE feature, explained in the next section, secures a minimum ON-time of about 100 ns.

8.4.4 Automatic Efficiency Enhancement (AEE™)

AEE™ provides highest efficiency over the entire input voltage and output voltage range by automatically adjusting the converter's switching frequency. This is achieved by setting the predictive off-time of the converter.

The efficiency of a switched mode converter is determined by the power losses during the conversion. The efficiency decreases, if V_{OUT} decreases and/or V_{IN} increases. In order to keep the efficiency high over the entire duty cycle range (V_{OUT}/V_{IN} ratio), the switching frequency is adjusted while maintaining the ripple current. The following equation shows the relation between the inductor ripple current, switching frequency and duty cycle.

Device Functional Modes (continued)

$$\Delta I_L = V_{OUT} \cdot \left(\frac{1-D}{L \cdot f_{SW}} \right) = V_{OUT} \cdot \left(\frac{1 - \frac{V_{OUT}}{V_{IN}}}{L \cdot f_{SW}} \right) \tag{7}$$

Efficiency increases by decreasing switching losses, preserving high efficiency for varying duty cycles, while the ripple current amplitude remains low enough to deliver the full output current without reaching current limit. The AEE™ feature provides an efficiency enhancement for various duty cycles, especially for lower Vout values, where fixed frequency converters suffer from a significant efficiency drop. Furthermore, this feature compensates for the very small duty cycles of high VIN to low VOUT conversion, which limits the control range in other topologies.

Figure 8 shows the typical switching frequency over the input voltage range.

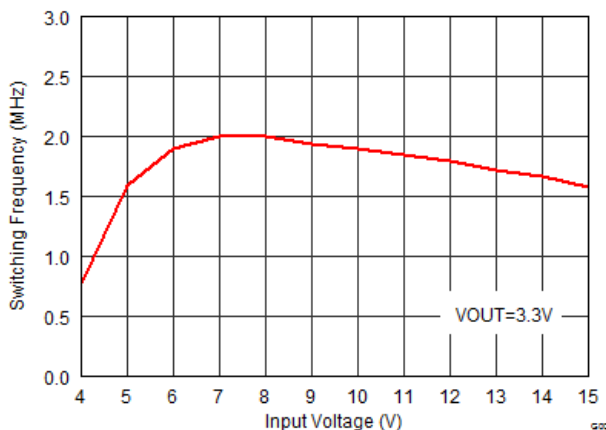

Figure 8. Typical Switching Frequency vs Input Voltage

8.4.5 Phase-Shifted Operation

While, for a buck converter, the input current source provides the average current that is needed to support the output current, an input capacitance is needed to support pulse currents. One of the natural benefits of a two- (or multi-) phase converter is the possibility to operate out of phase, which decreases the pulse currents and switching noise. In PWM mode, the TPS62184 runs with a fixed delay of typically 250 ns between the phases. This ensures that the phases run phase-delayed, limiting input RMS current and corresponding noise. If in PSM, both phases run, the phase delay is about 100 ns.

8.4.6 Current Limit, Current Balancing, and Short Circuit Protection

Each phase has a separate integrated peak current limit. While its minimum value limits the output current of the phase, the maximum number gives the current that must be considered to flow in any operating case. If the current limit of a phase is reached, the peak current setpoint is unable to increase further. The device provides its maximum output current. Detecting this heavy load or short circuit condition for about 0.9 ms, the device switches off for about 5 ms and then restarts again with a soft start cycle. As long as the overload condition is present, the device hiccups that way, limiting the output power.

The two phases are peak current balanced with a variation within about ±10% at 6-A output current. Since the control topology does not depend on inductor or output current measurements, the current balancing accuracy is independent of inductor matching (binning) and does not need matched power routing.

Device Functional Modes (continued)

8.4.7 Tracking

V_{OUT} can track a voltage that is applied at the SS/TR pin. The tracking range at the SS/TR pin is 50 mV to 1.2 V and the FB pin voltage tracks this as given in [Equation 8](#):

$$V_{FB} \approx 0.64 \cdot V_{SS/TR} \quad (8)$$

Due to the factor of about 0.64, the minimum output voltage for tracking is 1.25 V. Once the SS/TR pin voltage reaches about 1.2 V, the internal voltage is clamped to the internal feedback voltage and the device goes to normal regulation. This works for falling tracking voltage as well. If, in this case, the SS/TR voltage decreases, the device does not sink current from the output. Thus, the resulting decrease of the output voltage may be slower than the SS/TR pin voltage if the load is light. When driving the SS/TR pin with an external voltage, do not exceed the voltage rating of the SS/TR pin which is $V_{IN}+0.3$ V.

Note: If the voltage at the FB pin is below its typical value of 0.8 V, the output voltage accuracy may have a wider tolerance than specified.

9 Application and Implementation

NOTE

Information in the following applications sections is not part of the TI component specification, and TI does not warrant its accuracy or completeness. TI's customers are responsible for determining suitability of components for their purposes. Customers should validate and test their design implementation to confirm system functionality.

9.1 Application Information

The TPS62184 is a switched mode step-down converter, able to convert a 4-V to 17-V input voltage into a 0.9-V to 3.5-V output voltage, providing up to 6 A. It needs a minimum amount of external components. Apart from the LC output filter and the input capacitors only an optional pull-up resistor for Power Good (PG) and a small capacitor for adjustable soft start are used. To adjust the output voltage, a resistive divider is needed.

9.2 Typical Applications

9.2.1 Typical TPS62184 Application

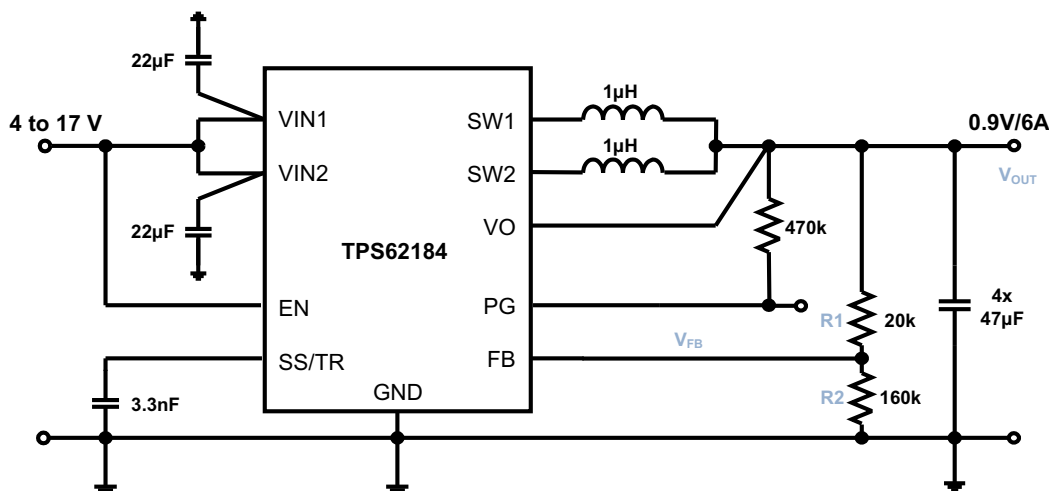

Figure 9. Typical 4-V to 17-V Input, 0.9-V Output Converter

9.2.1.1 Design Requirements

The design guideline provides a component selection to operate the device within the recommended operating conditions. The component selection is given as follows:

Table 1. Components Used for Application Characteristics

REFERENCE NAME	DESCRIPTION / VALUE	MANUFACTURER ⁽¹⁾
TPS62184YZF	2 phase step down converter, 2 x 3 mm WCSP	Texas Instruments
L1, L2	Inductor XFL4020-102ME, 1 µH ±20%, 4 x 4 x 2.1 mm	Coilcraft
C _{IN}	Ceramic capacitor GRM21BR61E226ME44, 2 x 22 µF, 25 V, X5R, 0805	muRata
C _{OUT}	Ceramic capacitor GRM21BR60J476ME15, 4 x 47 µF, 6.3 V, X5R, 0805	muRata
C _{SS}	Ceramic capacitor, 3.3 nF	Standard
R1	Chip resistor, value depending on V _{OUT}	Standard
R2	Chip resistor, value depending on V _{OUT}	Standard
R3	Chip resistor, 470 kΩ, 0603, 1/16 W, 1%	Standard

(1) See [Third-Party Products Disclaimer](#)

9.2.1.2 Detailed Design Procedure

9.2.1.2.1 Programming the Output Voltage

The output voltage of the TPS62184 is programmed using an external resistive divider. While the voltage at the FB pin is regulated to 0.8 V, the output voltage range is specified from 0.9 up to 3.5 V. The value of the output voltage is set by selection of the resistive divider (from V_{OUT} to FB to AGND) from [Equation 9](#).

$$\frac{R_1}{R_2} = \frac{V_{OUT}}{V_{FB}} - 1 \quad (9)$$

The current through those resistors contributes to the light load efficiency, which makes larger resistor values beneficial. However, to get sufficient noise immunity a minimum current of 5 μA is recommended. Using this, the resistor values are calculated by converting [Equation 9](#) as follows:

$$R_2 = \frac{V_{FB}}{I_{FB}} = \frac{0.8V}{5\mu A} = 160k\Omega \quad (10)$$

Inserting the R₂ value in [Equation 11](#), R₁ can be obtained.

$$R_1 = R_2 \cdot \left(\frac{V_{OUT}}{V_{FB}} - 1 \right) \quad (11)$$

Calculating for V_{OUT} = 1.0 V gives R₁ = 40 kΩ and R₂ = 160 kΩ.

In case the FB pin gets opened or an over voltage appears at the output, an internal clamp limits the output voltage to about 7.4 V.

9.2.1.2.2 Output Filter Selection

Since the TPS62184 is compensated internally, it is optimized for a range of external component values, which is specified below. [Table 2](#) and [Table 3](#) are used to simplify the output filter component selection.

Table 2. Recommended LC Output Filter Combinations for V_{OUT} ≥ 1.8 V⁽¹⁾

	2 x 47 μF	4 x 47 μF	6 x 47 μF	8 x 47 μF
0.47 μH				
1.0 μH	√	√	√	√
1.5 μH				

(1) The values in the table are the nominal values of inductors and ceramic capacitors. The effective capacitance can vary by +20 and -60%.

Table 3. Recommended LC Output Filter Combinations for V_{OUT} < 1.8 V⁽¹⁾

	2 x 47 μF	4 x 47 μF	6 x 47 μF	8 x 47 μF
0.68 μH				
1.0 μH		√	√	
1.5 μH				

(1) The values in the table are nominal values of inductors and ceramic capacitors. The effective capacitance can vary by +20 and -40%.

For the output capacitors, a voltage rating of 6.3 V and an X5R dielectric are chosen. If space allows for higher voltage rated capacitors in larger case sizes, the dc bias effect is lowered and the effective capacitance value increases.

9.2.1.2.3 Inductor Selection

The TPS62184 is designed to work with two inductors of 1 μH nominal. Inductors have to be selected for adequate saturation current and a low dc resistance (DCR). The minimum inductor current rating $I_{L(\min)}$ that is needed under static load conditions is calculated using [Equation 12](#) and [Equation 13](#). A current imbalance of 10% at most is incorporated.

$$I_{peak(max)} = I_{L(\min)} = \frac{1.1 \cdot I_{OUT(max)}}{2} + \frac{\Delta I_{L(max)}}{2} \quad (12)$$

$$\Delta I_{L(max)} = V_{OUT} \cdot \left(\frac{1 - \frac{V_{OUT}}{V_{IN(max)}}}{L_{(\min)} \cdot f_{SW}} \right) \quad (13)$$

This calculation gives the minimum saturation current of the inductor needed and an additional margin of about 20% is recommended to cover dynamic overshoot due to load transients. The maximum current limit can be reached during strong load transient or overload condition. To avoid device over stress due to inductor saturation in this case, the inductor rating must be as high as the max. current limit of 5A.

For low profile solutions, the physical inductor size and the power losses have to be traded off. Smallest solution size (for example with chip inductors) are less efficient than bigger inductors with lower losses due to lower DCR and/or core losses. The following inductors have been tested with the TPS62184:

Table 4. List of Inductors

TYPE	INDUCTANCE [μH]	CURRENT RATING MIN/TYP [A] ⁽¹⁾	DCR MAX [mΩ]	DIMENSIONS (LxBxH) [mm]	MANUFACTURER ⁽²⁾
DFE252012P-1R0M	1 ±20%	4.3/4.8	42	2.5 x 2.0 x 1.2	TOKO
PIFE32251B-1R0MS	1 ±20%	4.2/4.7	42	3.2 x 2.5 x 1.2	CYNTEC
PIME031B-1R0MS	1 ±20%	4.5/5.4	55	3.7 x 3.3 x 1.2	CYNTEC
IHLP1212AB-11	1 ±20%	/5.0	37.5	3.6 x 3.0 x 1.2	VISHAY
IHLP1212AE-11	1 ±20%	/5.3	33	3.6 x 3.0 x 1.5	VISHAY
744 373 24 010	1 ±20%	/>9	27	4.0 x 4.5 x 1.8	WUERTH
XAL4020-102ME_	1 ±20%	/8.7	14.6	4.0 x 4.0 x 2.1	COILCRAFT

(1) I_{SAT} at 30% drop of inductance ($\Delta L/L$).

(2) See [Third-Party Products Disclaimer](#)

The TPS62184 is not designed to operate with only one inductor.

9.2.1.2.4 Output Capacitor Selection

The TPS62184 provides an output voltage range of 0.9 V to 3.5 V. While stability is a critical criteria for the output filter selection, the output capacitor value also determines transient response behavior, ripple and accuracy of V_{OUT} . [Table 5](#) gives recommendations to achieve various transient design targets using 1-μH inductors and small sized output capacitors (see [Table 1](#)).

Table 5. Recommended Output Capacitor Values

OUTPUT VOLTAGE [V]	LOAD STEP [A]	(NOMINAL) CAPACITOR VALUE ⁽¹⁾	TYPICAL TRANSIENT RESPONSE ACCURACY	
			±mV	±%
0.9 ⁽²⁾	2-6-2 ⁽³⁾	4 x 47 µF	90	10
		6 x 47 µF	70	8
1.8	2-6-2 ⁽³⁾	2 x 47 µF	150	8
		4 x 47 µF	120	7
		8 x 47 µF	90	5
3.3	2-6-2 ⁽³⁾	2 x 47 µF	170	5
		4 x 47 µF	135	4
		8 x 47 µF	100	3

- (1) Ceramic capacitors have a dc bias effect where the effective capacitance differs significantly from the nominal value, depending on package size, voltage rating and dielectric material.
- (2) For output voltages < 1.8V an additional feedforward capacitor of 82pF, parallel to R₁ is recommended to increase stability margin at heavy load steps.
- (3) The transient load step is tested with 1-µs/step rising/falling slopes.

The architecture of the TPS62184 allows the use of tiny ceramic output capacitors with low equivalent series resistance (ESR). These capacitors provide low output voltage ripple and are recommended. To keep its low resistance up to high frequencies and to get narrow capacitance variation with temperature, it is recommended to use X7R or X5R dielectrics. Using even higher values than demanded for stability and transient response has further advantages like smaller voltage ripple and tighter dc output accuracy in Power Save Mode.

9.2.1.2.5 Input Capacitor Selection

The input current of a buck converter is pulsating. Therefore, a low ESR input capacitor is required to prevent large voltage transients and provide peak currents. The recommended value for most applications is 2 x 22 µF, split between the VIN1 and VIN2 inputs and placed as close as possible to these pins and PGND pins. If additional capacitance is needed, it can be added as bulk capacitance. To ensure proper operation, the effective capacitance at the VIN pins must not fall below 2 x 2 µF (close) + 10 µF bulk (effective capacitances).

Low ESR multilayer ceramic capacitors are recommended for best filtering. Increasing with input voltage, the dc bias effect reduces the nominal capacitance value significantly. To decrease input ripple current further, larger values of input capacitors can be used.

9.2.1.2.6 Soft Start Capacitor Selection

The TPS62184 provides a user programmable soft start time. A constant current source of 5 µA, internally connected to the SS/TR pin, allows control of the startup slope by connecting a capacitor to this pin. The current source charges the capacitor and the soft start time is given by:

$$C_{SS} = t_{SS} \cdot \frac{5\mu A}{1.25V} \quad (14)$$

where C_{SS} is the soft-start capacitance required at the SS/TR pin and t_{SS} is the resulting soft-start ramp time.

The SS/TR pin should not be left floating and a minimum capacitance of 220 pF is recommended. Using Equation 14, and inserting t_{SS} = 750 µs, a value of 3 nF is calculated. 3.3 nF is chosen as a standard value for this example.

9.2.1.2.7 Using the Accurate EN Threshold

The TPS62184 provides a very accurate EN threshold voltage. This can be used to switch on the device according to a V_{IN} or another voltage level by using a resistive divider as shown below. The values of R_{EN1} and R_{EN2} , needed to set $EN = High$ at a specific V_{IN} can be calculated according to Kirchhoff's laws, shown in Equation 15 and used in the following example:

$$V_{IN} = V_{EN_threshold} \cdot \frac{R_{EN1} + R_{EN2}}{R_{EN2}} \tag{15}$$

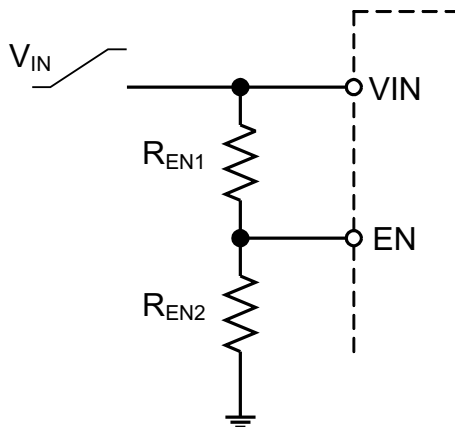

Figure 10. Resistive Divider for Controlled EN Threshold

For a typical 8-V input rail, the device turn on target value is set to 5.5 V. The current through the resistive divider is set to 10 μA , which indicates a total resistance of about 800 k Ω . Appropriate standard resistor values, fitting Equation 15, are $R_{EN1} = 680$ k Ω and $R_{EN2} = 150$ k Ω . As a result, the device switches on, when V_{IN} has reached 5.5 V and the current through the divider is 9.6 μA . The device switches off at a threshold of 0.9 V. Using Equation 15 again, this case gives a level of $V_{IN} = 5.0$ V.

Figure 31 to Figure 34 show thresholds and appropriate device behavior with a startup time of about 800 μs .

9.2.1.3 Application Performance Curves

$V_{IN} = 12\text{ V}$, $V_{OUT} = 3.3\text{ V}$, $T_A = 25^\circ\text{C}$, (unless otherwise noted)

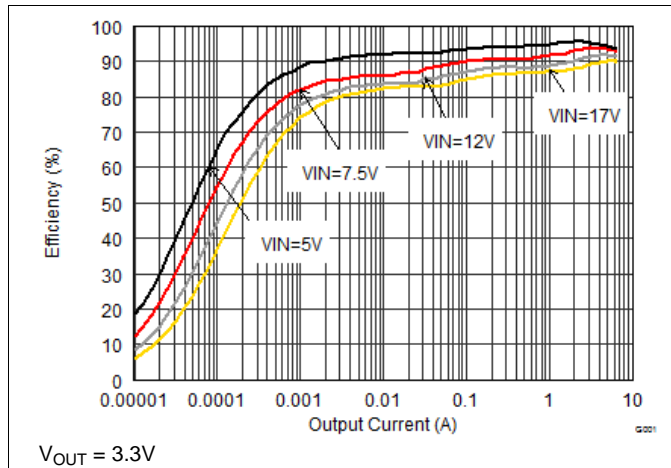

Figure 11. Efficiency vs Load Current

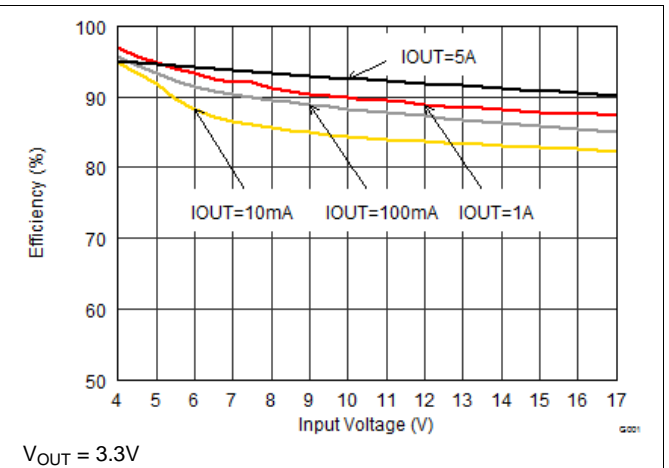

Figure 12. Efficiency vs Input Voltage

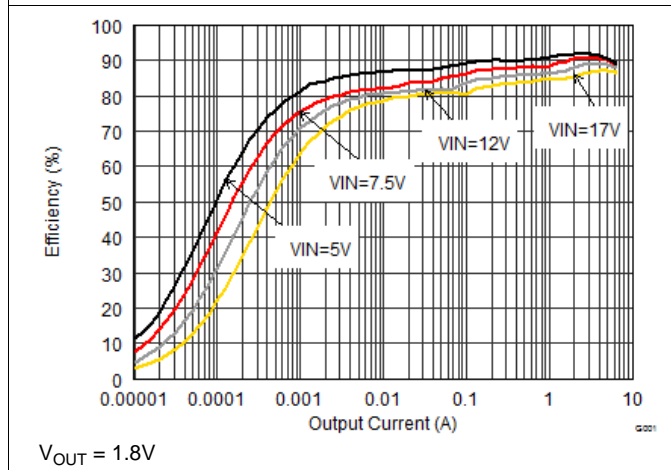

Figure 13. Efficiency vs Load Current

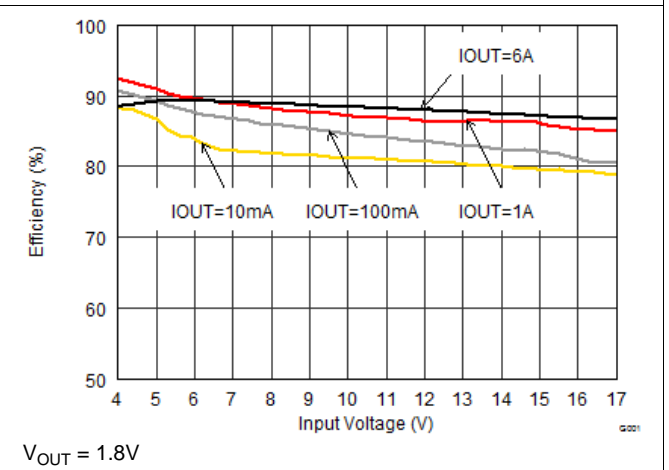

Figure 14. Efficiency vs Input Voltage

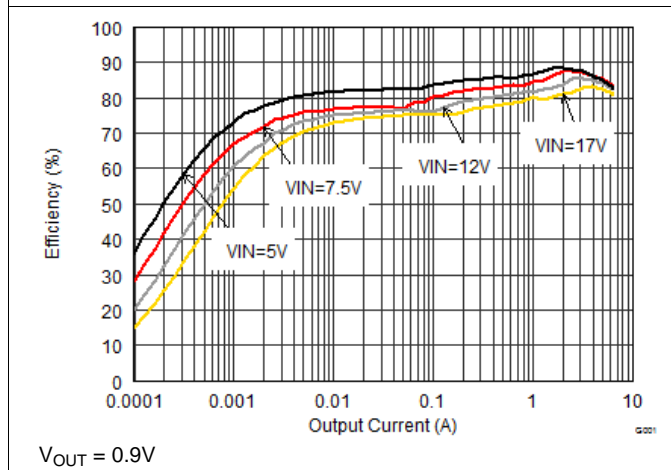

Figure 15. Efficiency vs Load Current

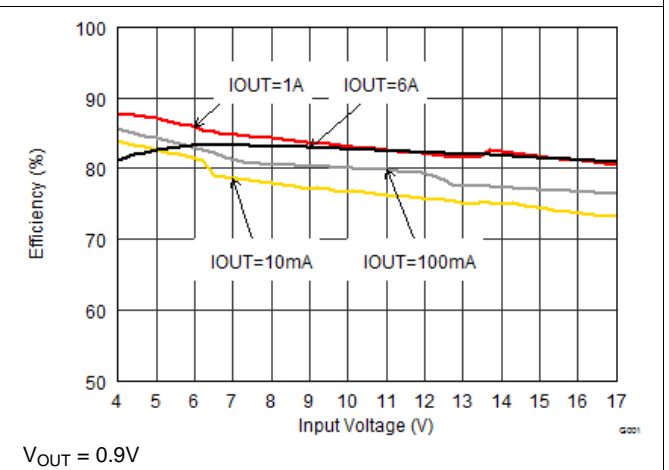

Figure 16. Efficiency vs Input Voltage

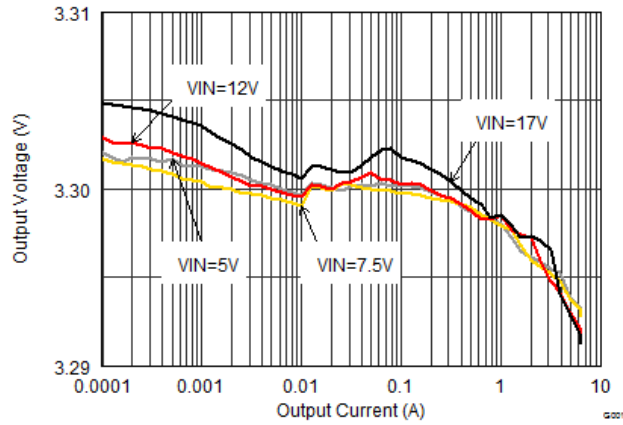

Figure 17. Output Voltage vs Output Current (Load regulation)

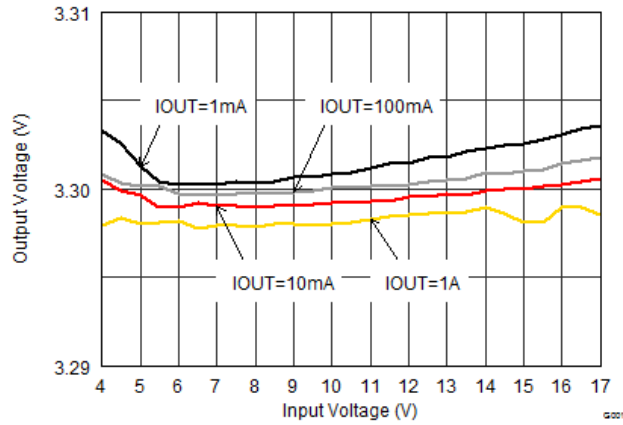
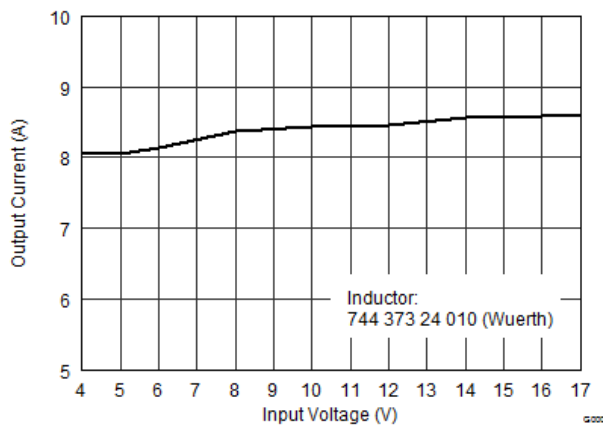
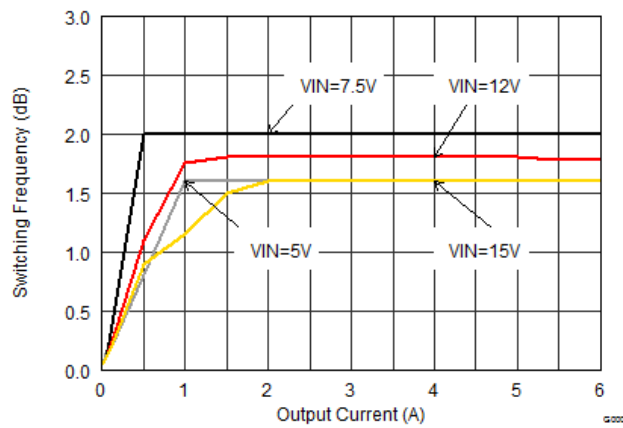

Figure 18. Output Voltage vs Input Voltage (Line regulation)



$V_{OUT} = 0.9V$

Figure 19. Maximum Output Current vs Input Voltage



$V_{OUT} = 3.3V$

Figure 20. Switching Frequency vs Output Current

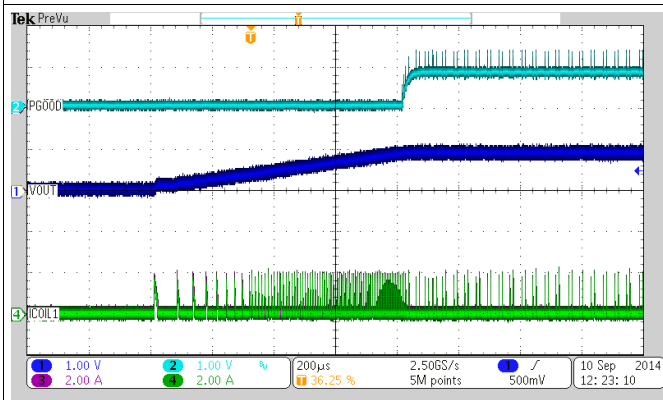

$V_{OUT} = 0.9V$

Figure 21. Startup into 10 Ω (90 mA)

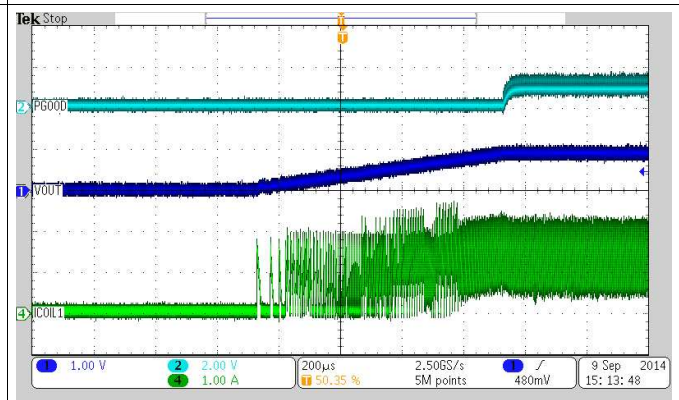

$V_{OUT} = 0.9V$

Figure 22. Startup into 0.33 Ω (2.73 A)

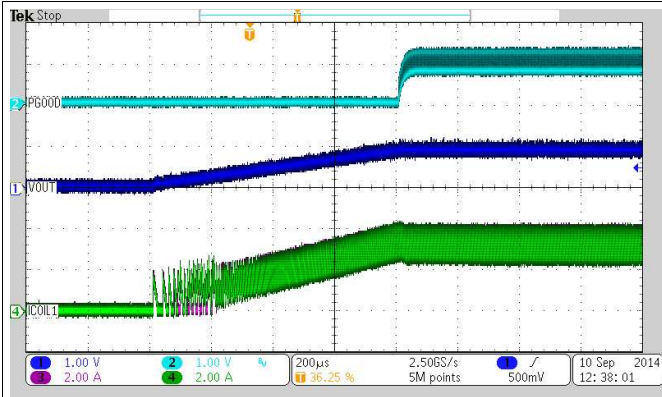

$V_{OUT} = 0.9V$

Figure 23. Startup into 0.135 Ω (6.6 A)

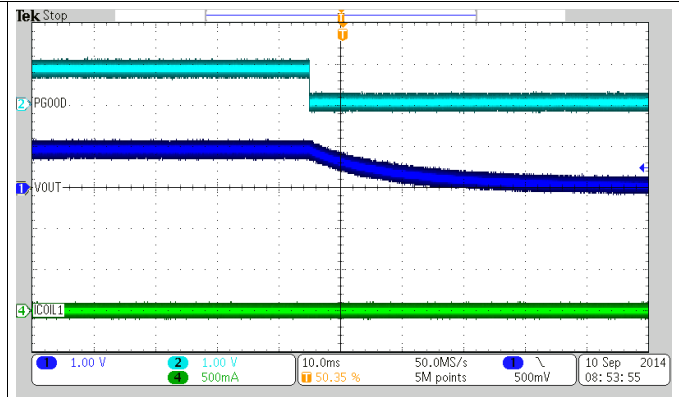

$V_{OUT} = 0.9V$

Figure 24. Output Discharge (No load)

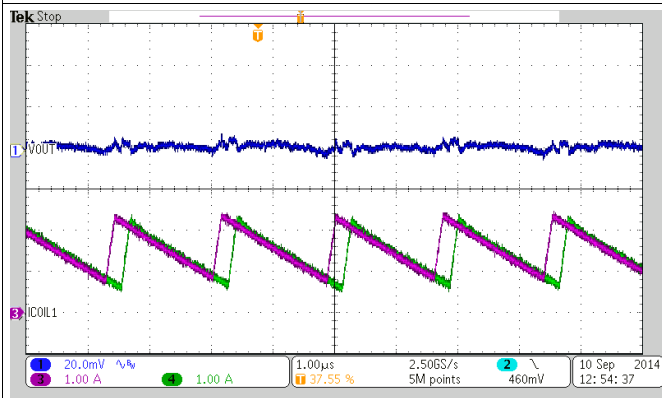

$I_{OUT} = 3 A$ $V_{OUT} = 0.9V$

Figure 25. Typical Operation (PWM)

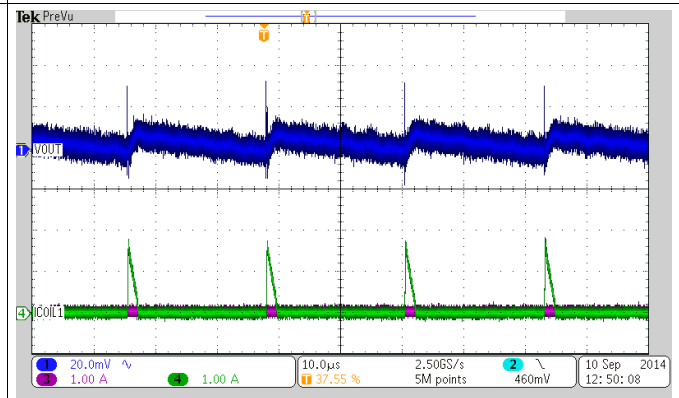

$I_{OUT} = 50 mA$ $V_{OUT} = 0.9V$

Figure 26. Typical Operation (PSM)

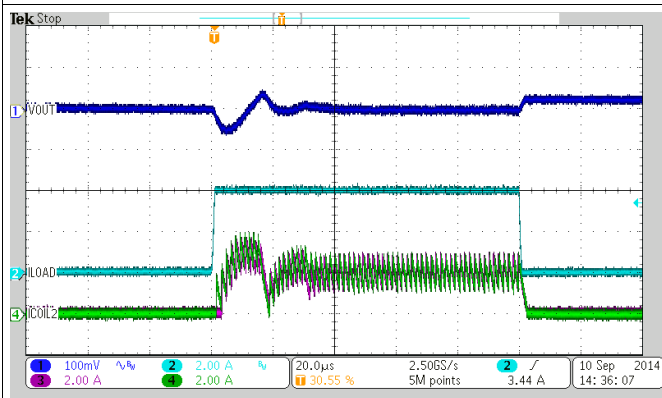

$C_{OUT} = 6 \times 47 \mu F$ $V_{OUT} = 0.9V$

Figure 27. Load Transient Response (PSM-PWM)

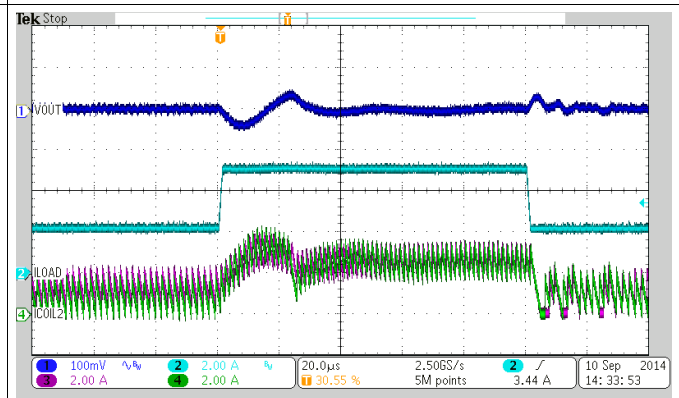

$C_{OUT} = 6 \times 47 \mu F$ $V_{OUT} = 0.9V$

Figure 28. Load Transient Response (PWM-PWM)

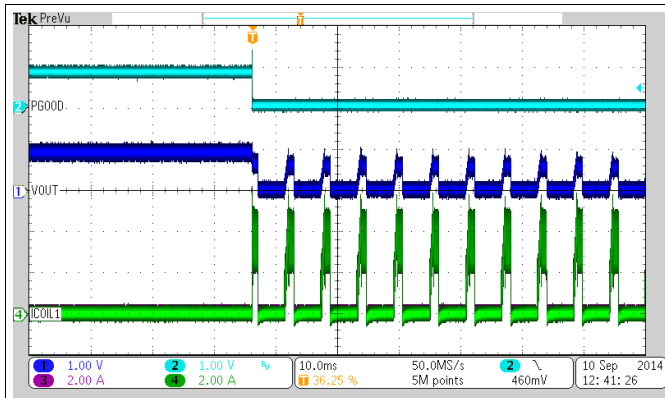

Figure 29. HICCUP at Short Circuit

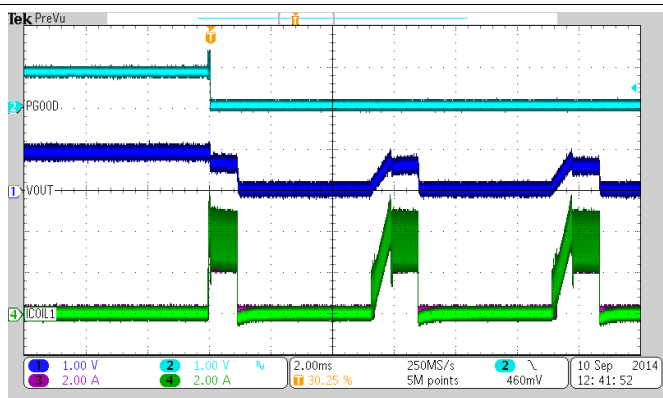

Figure 30. HICCUP at Short Circuit

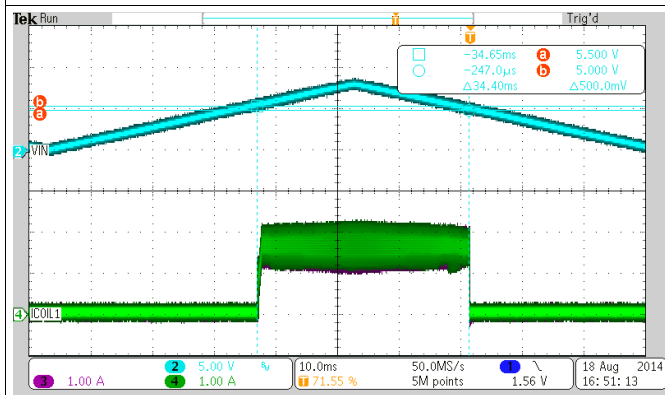

Figure 31. Accurate EN Threshold

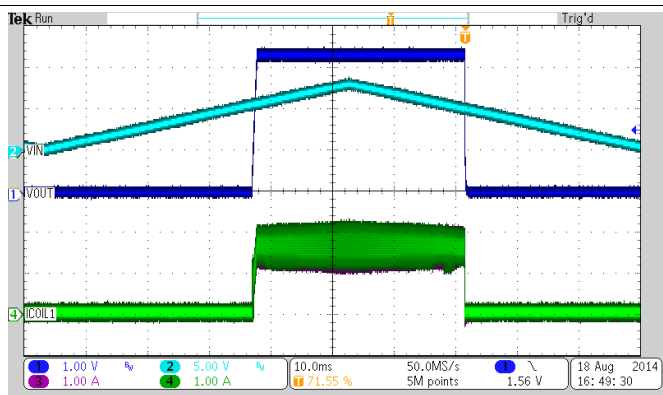

Figure 32. Accurate EN Threshold Showing V_{OUT}

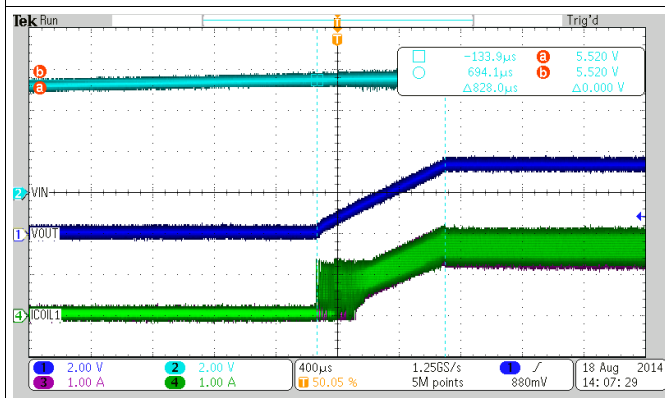

Figure 33. Accurate EN Threshold

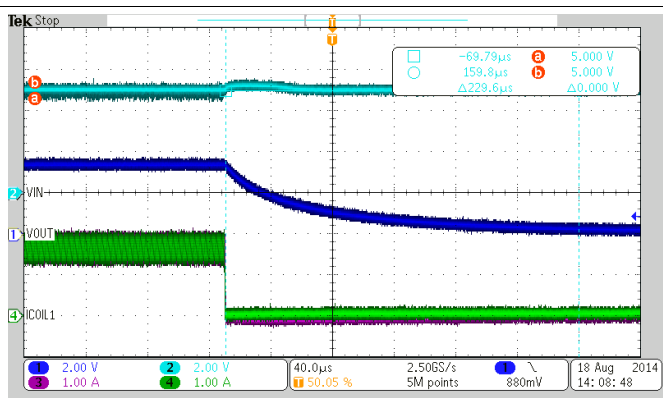

Figure 34. Accurate EN Threshold

9.3 System Examples

Based on Figure 9, the schematics shown in Figure 35 through Figure 39 show different output voltage divider values to get different V_{OUT} . Another design target is to have about $5\text{-}\mu\text{A}$ current through the divider.

The values for the voltage divider are derived using the procedure given in *Programming the Output Voltage*. While Equation 10 and Equation 11 are used to calculate R2 and R1, the values are aligned with standard resistor values.

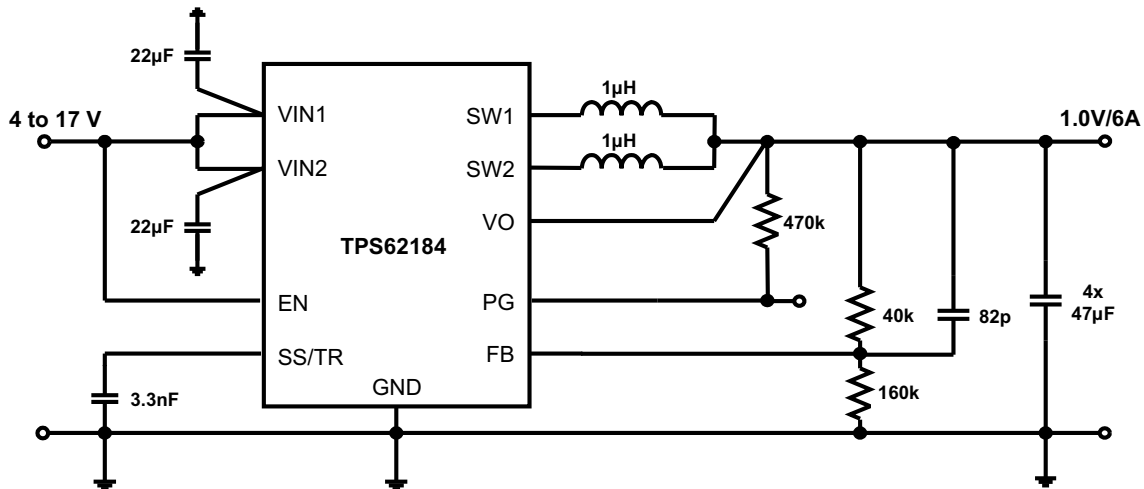

Figure 35. 1.0-V/6-A Power Supply

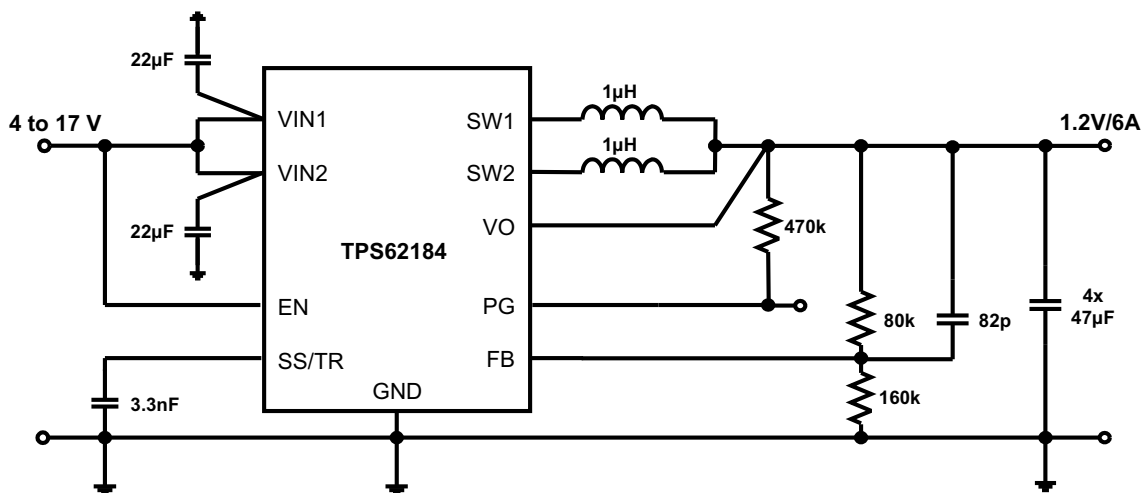

Figure 36. 1.2-V/6-A Power Supply

System Examples (continued)

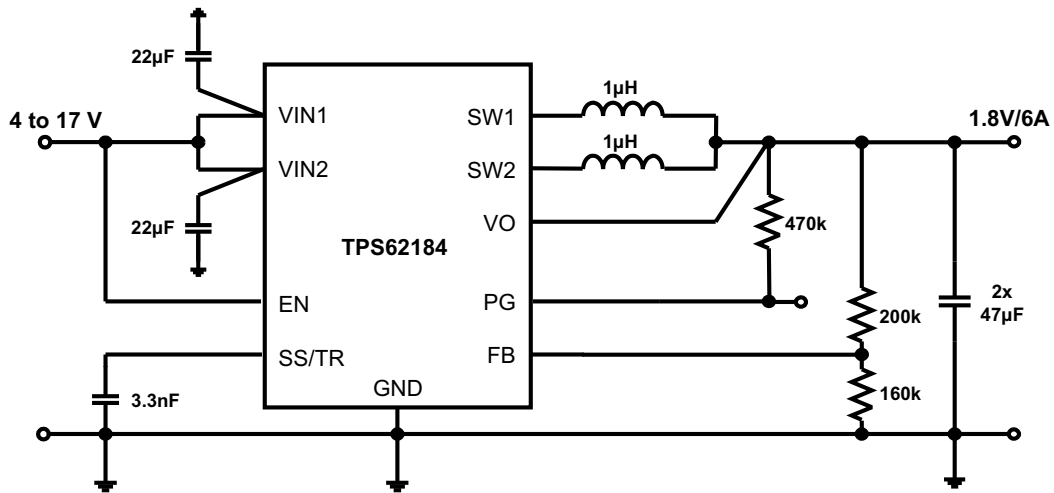

Figure 37. 1.8-V/6-A Power Supply

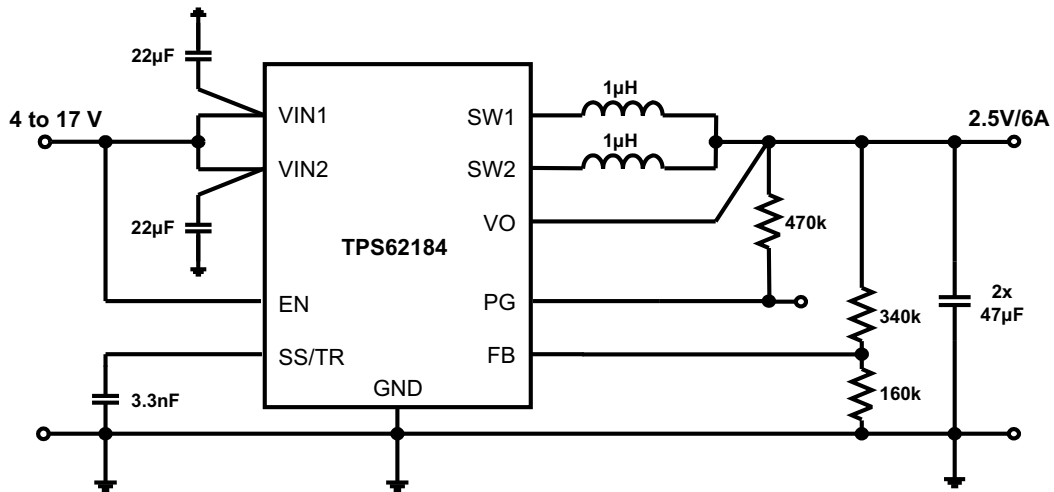
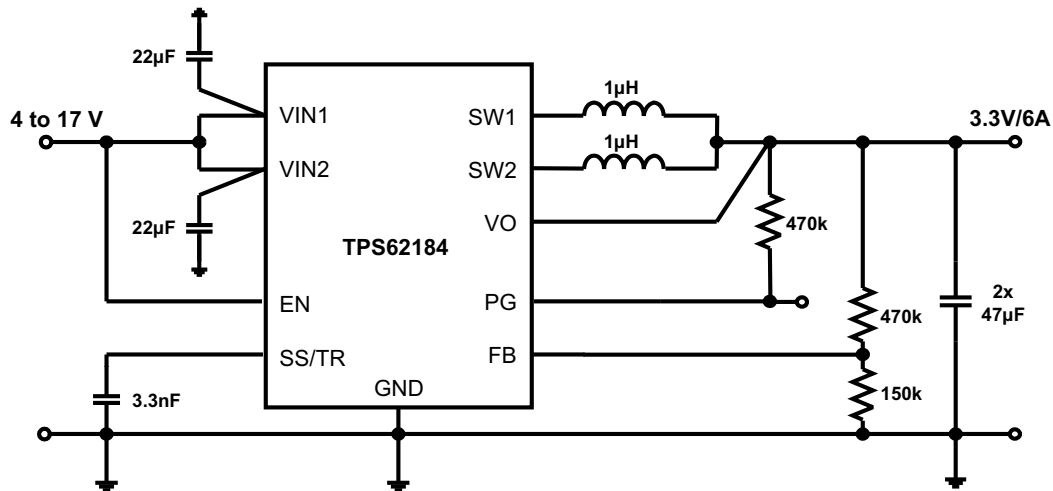

Figure 38. 2.5-V/6-A Power Supply

System Examples (continued)

Figure 39. 3.3-V/6-A Power Supply
10 Power Supply Recommendations

The TPS62184 is designed to operate from a 4-V to 17-V input voltage supply. The input power supply's output current needs to be rated according to the output voltage and the output current of the power rail application.

11 Layout

11.1 Layout Guidelines

The PCB layout of the TPS62184 demands careful attention to ensure proper operation, thermal profile, low noise emission and to achieve best performance. A poor layout can lead to issues like poor regulation, stability and accuracy weaknesses, increased EMI radiation and noise sensitivity. While the TPS62184 provides very high power density, the PCB layout also contributes significantly to the thermal performance.

11.1.1 PCB layout

A recommended PCB layout for the TPS62184 dual phase solution is shown below. It ensures best electrical and optimized thermal performance considering the following important topics:

- The input capacitors must be placed as close as possible to the appropriate pins of the device. This provides low resistive and inductive paths for the high di/dt input current. The input capacitance is split, as is the V_{IN} connection, to avoid interference between the input lines.
- The SW node connection from the IC to the inductor conducts high currents. It should be kept short and can be designed in parallel with an internal or bottom layer plane, to provide low resistance and enhanced thermal behavior.
- The V_{OUT} regulation loop is closed with C_{OUT} and its ground connection. If a ground layer or plane is used, a direct connection by vias, as shown, is recommended. Otherwise the connection of C_{OUT} to GND must be short for good load regulation.
- The FB node is sensitive to dv/dt signals. Therefore the resistive divider should be placed close to the FB pin, avoiding long trace distance.

11.2 Layout Example

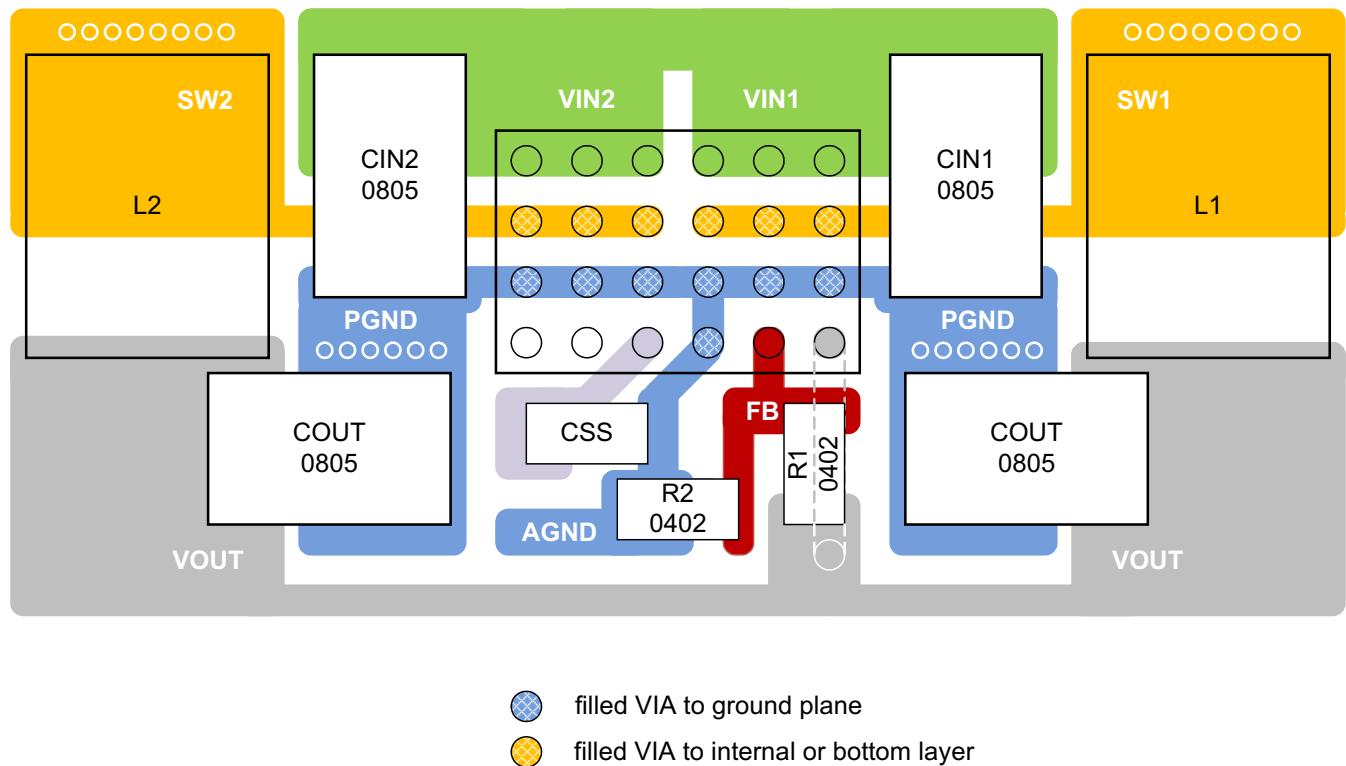

Figure 40. TPS62184 Board Layout

12 器件和文档支持

12.1 器件支持

12.1.1 第三方产品免责声明

TI 发布的与第三方产品或服务有关的信息，不能构成与此类产品或服务或保修的适用性有关的认可，不能构成此类产品或服务单独或与任何 TI 产品或服务一起的表示或认可。

12.2 商标

AEE, NanoFree are trademarks of Texas Instruments.
All other trademarks are the property of their respective owners.

12.3 静电放电警告



这些装置包含有限的内置 ESD 保护。存储或装卸时，应将导线一起截短或将装置放置于导电泡棉中，以防止 MOS 门极遭受静电损伤。

12.4 术语表

[SLYZ022](#) — TI 术语表。

这份术语表列出并解释术语、首字母缩略词和定义。

13 机械封装和可订购信息

以下页中包括机械封装和可订购信息。 这些信息是针对指定器件可提供的最新数据。 这些数据会在无通知且不对本文档进行修订的情况下发生改变。 欲获得该数据表的浏览器版本，请查阅左侧的导航栏。

PACKAGING INFORMATION

Orderable Device	Status (1)	Package Type	Package Drawing	Pins	Package Qty	Eco Plan (2)	Lead finish/ Ball material (6)	MSL Peak Temp (3)	Op Temp (°C)	Device Marking (4/5)	Samples
TPS62184YZFR	ACTIVE	DSBGA	YZF	24	3000	RoHS & Green	SNAGCU	Level-1-260C-UNLIM	-40 to 125	ELC184	Samples
TPS62184YZFT	ACTIVE	DSBGA	YZF	24	250	RoHS & Green	SNAGCU	Level-1-260C-UNLIM	-40 to 125	ELC184	Samples

(1) The marketing status values are defined as follows:

ACTIVE: Product device recommended for new designs.

LIFEBUY: TI has announced that the device will be discontinued, and a lifetime-buy period is in effect.

NRND: Not recommended for new designs. Device is in production to support existing customers, but TI does not recommend using this part in a new design.

PREVIEW: Device has been announced but is not in production. Samples may or may not be available.

OBSOLETE: TI has discontinued the production of the device.

(2) **RoHS:** TI defines "RoHS" to mean semiconductor products that are compliant with the current EU RoHS requirements for all 10 RoHS substances, including the requirement that RoHS substance do not exceed 0.1% by weight in homogeneous materials. Where designed to be soldered at high temperatures, "RoHS" products are suitable for use in specified lead-free processes. TI may reference these types of products as "Pb-Free".

RoHS Exempt: TI defines "RoHS Exempt" to mean products that contain lead but are compliant with EU RoHS pursuant to a specific EU RoHS exemption.

Green: TI defines "Green" to mean the content of Chlorine (Cl) and Bromine (Br) based flame retardants meet JS709B low halogen requirements of <=1000ppm threshold. Antimony trioxide based flame retardants must also meet the <=1000ppm threshold requirement.

(3) MSL, Peak Temp. - The Moisture Sensitivity Level rating according to the JEDEC industry standard classifications, and peak solder temperature.

(4) There may be additional marking, which relates to the logo, the lot trace code information, or the environmental category on the device.

(5) Multiple Device Markings will be inside parentheses. Only one Device Marking contained in parentheses and separated by a "~" will appear on a device. If a line is indented then it is a continuation of the previous line and the two combined represent the entire Device Marking for that device.

(6) Lead finish/Ball material - Orderable Devices may have multiple material finish options. Finish options are separated by a vertical ruled line. Lead finish/Ball material values may wrap to two lines if the finish value exceeds the maximum column width.

Important Information and Disclaimer:The information provided on this page represents TI's knowledge and belief as of the date that it is provided. TI bases its knowledge and belief on information provided by third parties, and makes no representation or warranty as to the accuracy of such information. Efforts are underway to better integrate information from third parties. TI has taken and continues to take reasonable steps to provide representative and accurate information but may not have conducted destructive testing or chemical analysis on incoming materials and chemicals. TI and TI suppliers consider certain information to be proprietary, and thus CAS numbers and other limited information may not be available for release.

In no event shall TI's liability arising out of such information exceed the total purchase price of the TI part(s) at issue in this document sold by TI to Customer on an annual basis.

TAPE AND REEL INFORMATION

QUADRANT ASSIGNMENTS FOR PIN 1 ORIENTATION IN TAPE

*All dimensions are nominal

Device	Package Type	Package Drawing	Pins	SPQ	Reel Diameter (mm)	Reel Width W1 (mm)	A0 (mm)	B0 (mm)	K0 (mm)	P1 (mm)	W (mm)	Pin1 Quadrant
TPS62184YZFR	DSBGA	YZF	24	3000	330.0	12.4	2.25	3.25	0.81	4.0	12.0	Q1
TPS62184YZFT	DSBGA	YZF	24	250	330.0	12.4	2.25	3.25	0.81	4.0	12.0	Q1

TAPE AND REEL BOX DIMENSIONS

*All dimensions are nominal

Device	Package Type	Package Drawing	Pins	SPQ	Length (mm)	Width (mm)	Height (mm)
TPS62184YZFR	DSBGA	YZF	24	3000	335.0	335.0	25.0
TPS62184YZFT	DSBGA	YZF	24	250	335.0	335.0	25.0

YZF0024

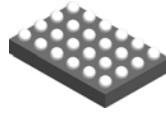

PACKAGE OUTLINE

DSBGA - 0.625 mm max height

DIE SIZE BALL GRID ARRAY

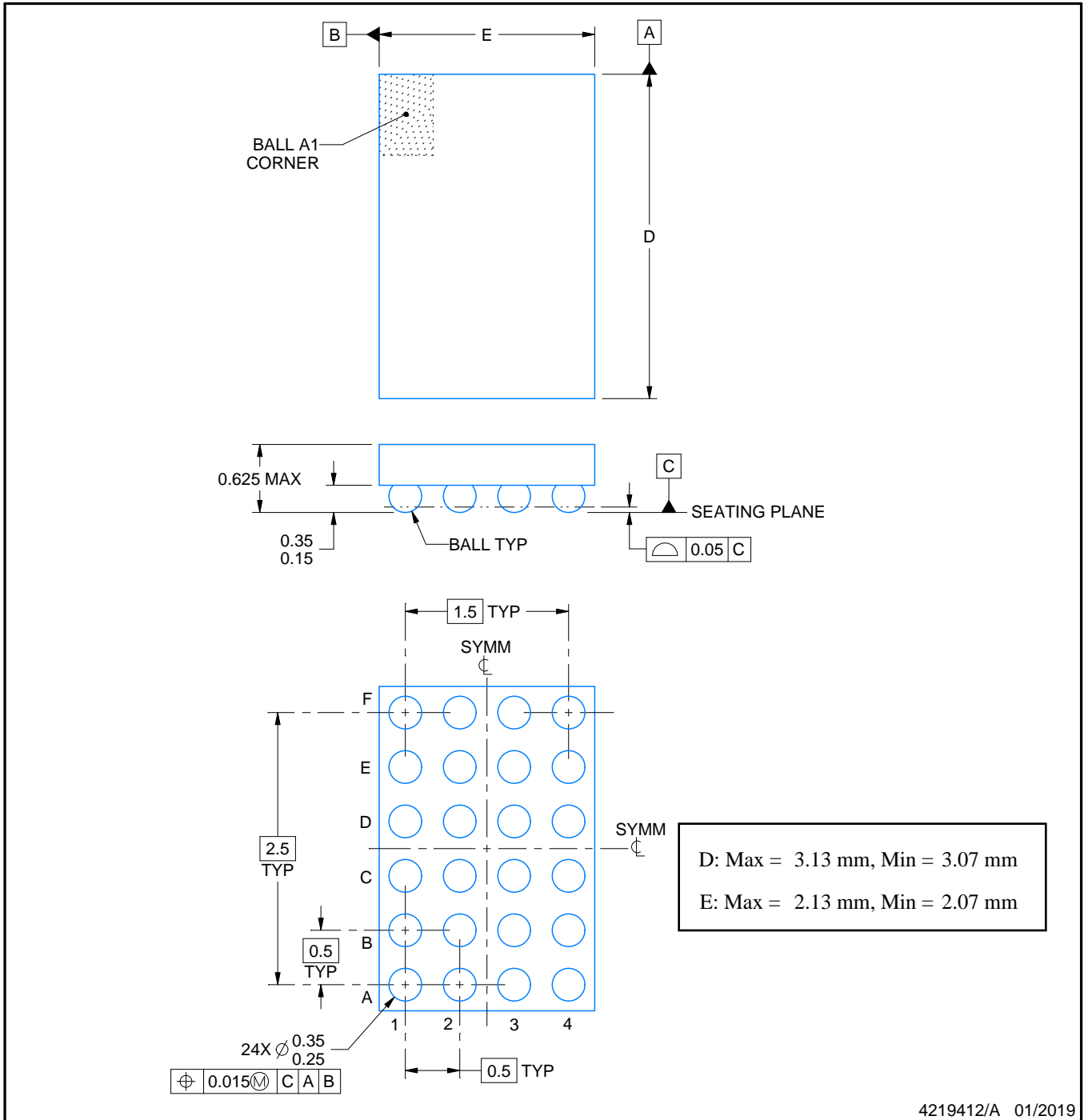

NOTES:

NanoFree is a trademark of Texas Instruments.

1. All linear dimensions are in millimeters. Any dimensions in parenthesis are for reference only. Dimensioning and tolerancing per ASME Y14.5M.
2. This drawing is subject to change without notice.
3. NanoFree™ package configuration.

EXAMPLE BOARD LAYOUT

YZF0024

DSBGA - 0.625 mm max height

DIE SIZE BALL GRID ARRAY

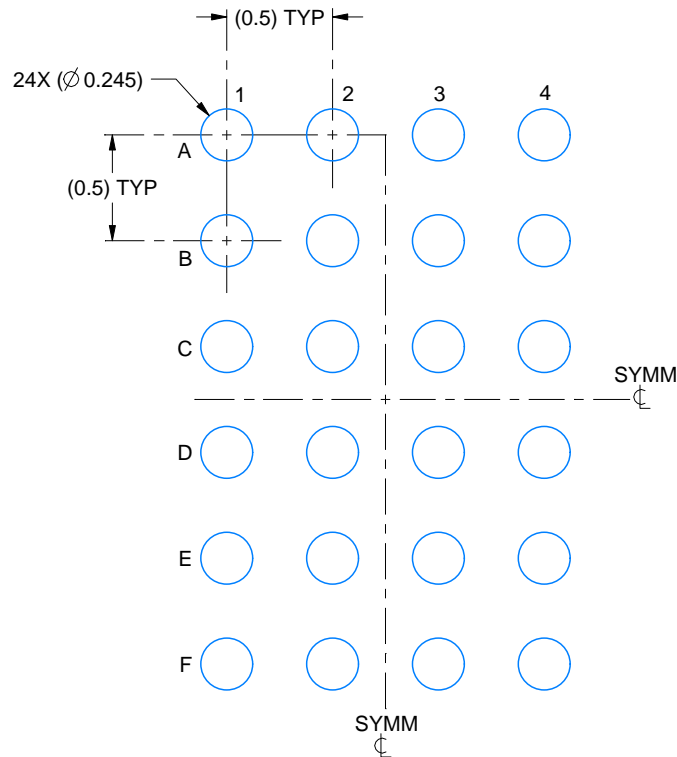

LAND PATTERN EXAMPLE
EXPOSED METAL SHOWN
SCALE:28X

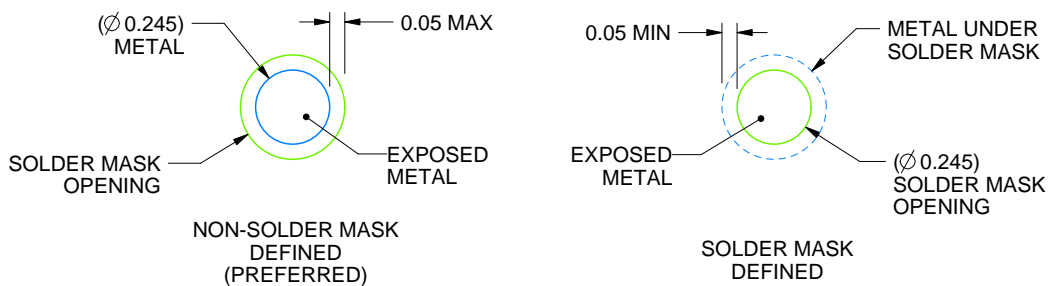

SOLDER MASK DETAILS
NOT TO SCALE

4219412/A 01/2019

NOTES: (continued)

- Final dimensions may vary due to manufacturing tolerance considerations and also routing constraints. For more information, see Texas Instruments literature number SNVA009 (www.ti.com/lit/snva009).

EXAMPLE STENCIL DESIGN

YZF0024

DSBGA - 0.625 mm max height

DIE SIZE BALL GRID ARRAY

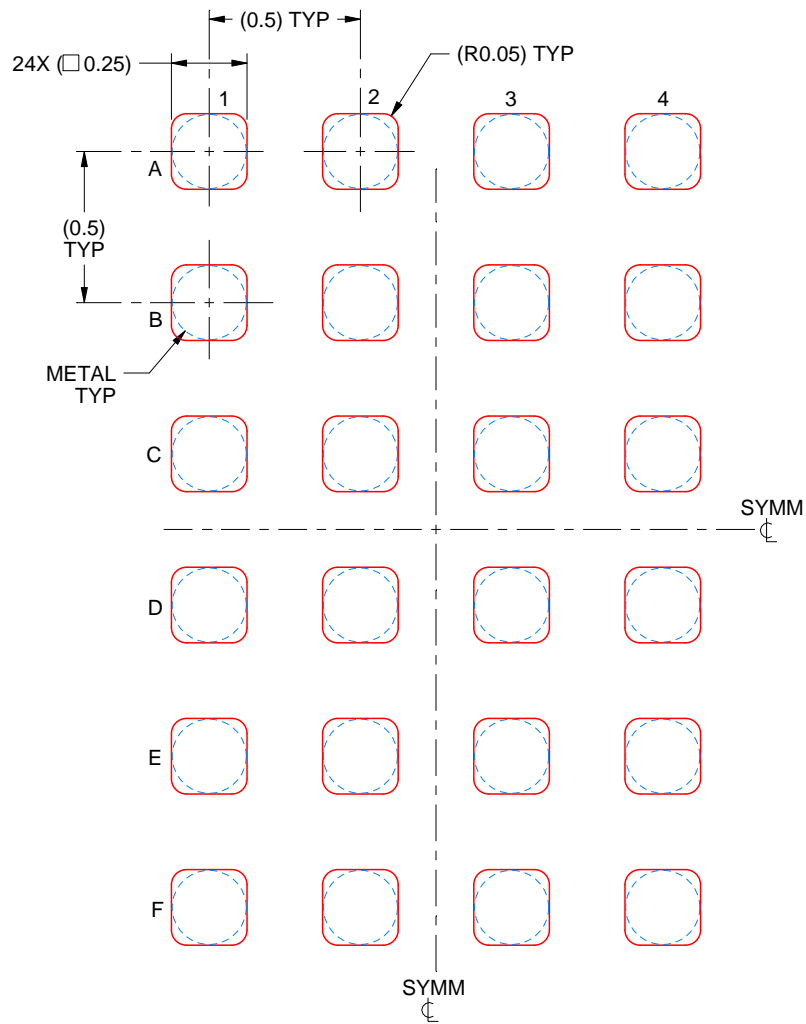

SOLDER PASTE EXAMPLE
BASED ON 0.1 mm THICK STENCIL
SCALE:40X

4219412/A 01/2019

NOTES: (continued)

5. Laser cutting apertures with trapezoidal walls and rounded corners may offer better paste release.

重要声明和免责声明

TI“按原样”提供技术和可靠性数据（包括数据表）、设计资源（包括参考设计）、应用或其他设计建议、网络工具、安全信息和其他资源，不保证没有瑕疵且不做任何明示或暗示的担保，包括但不限于对适销性、某特定用途方面的适用性或不侵犯任何第三方知识产权的暗示担保。

这些资源可供使用 TI 产品进行设计的熟练开发人员使用。您将自行承担以下全部责任：(1) 针对您的应用选择合适的 TI 产品，(2) 设计、验证并测试您的应用，(3) 确保您的应用满足相应标准以及任何其他功能安全、信息安全、监管或其他要求。

这些资源如有变更，恕不另行通知。TI 授权您仅可将这些资源用于研发本资源所述的 TI 产品的应用。严禁对这些资源进行其他复制或展示。您无权使用任何其他 TI 知识产权或任何第三方知识产权。您应全额赔偿因在这些资源的使用中对 TI 及其代表造成的任何索赔、损害、成本、损失和债务，TI 对此概不负责。

TI 提供的产品受 [TI 的销售条款](#) 或 [ti.com](#) 上其他适用条款/TI 产品随附的其他适用条款的约束。TI 提供这些资源并不会扩展或以其他方式更改 TI 针对 TI 产品发布的适用的担保或担保免责声明。

TI 反对并拒绝您可能提出的任何其他或不同的条款。

邮寄地址：Texas Instruments, Post Office Box 655303, Dallas, Texas 75265

Copyright © 2023，德州仪器 (TI) 公司