

UCD8220 Digitally Managed Push-Pull Analog PWM Controllers

1 Features

- For digitally managed power supplies using μCs or the TMS320™ DSP family
- Voltage or peak current mode control with cycle-by-cycle current limiting
- Clock input from digital controller to set operating frequency and max duty cycle
- Analog PWM comparator
- 2-MHz switching frequency
- 110-V input startup circuit and thermal shutdown (UCD8620)
- Internal programmable slope compensation
- 3.3-V, 10-mA linear regulator
- DSP/ μC compatible inputs
- Dual $\pm 4\text{-A}$ TrueDrive™ integrated circuit high current drivers
- 10-ns typical rise and fall times with 2.2-nF
- 25-ns input-to-output propagation delay
- 25-ns current sense-to-output propagation delay
- Programmable current-limit threshold
- Digital output current-limit flag
- 4.5-V to 15.5-V supply voltage range
- Rated from -40°C to 105°C

2 Applications

- Digitally managed switch mode power supplies
- Push-pull, half-bridge, or full-bridge converters
- Battery chargers

3 Description

The UCD8220 analog pulse-width modulator (PWM) device is used in digitally managed power supplies using a microcontroller or the TMS320 DSP family.

The UCD8220 device is a double-ended PWM controller configured with push-pull drive logic.

Systems using the UCD8220 device close the PWM feedback loop with traditional analog methods, but the UCD8220 controller includes circuitry to interpret a time-domain digital pulse train. The pulse train contains the operating frequency and maximum duty cycle limit which are used to control the power supply operation. The device circuitry eases implementation of a converter with high level control features without the added complexity or possible PWM resolution limitations of closing the control loop in the discrete time domain.

The UCD8220 device can be configured for either peak current mode or voltage mode control. The device provides a programmable current-limit function and a digital output current-limit flag which can be monitored by the host controller to set the current limit operation. For fast switching speeds, the output stage uses the TrueDrive output circuit architecture, which delivers rated current of $\pm 4\text{-A}$ into the gate of a MOSFET. Finally the device also includes a 3.3-V, 10-mA linear regulator to provide power to the digital controller or act as a reference in the system.

The UCD8220 controller is compatible with the standard 3.3-V I/O ports of UCD9K digital power controllers, DSPs, microcontrollers, or ASICs and is offered in the PowerPAD™ integrated circuit package HTSSOP.

Device Information⁽¹⁾

PART NUMBER	PACKAGE	BODY SIZE (NOM)
UCD8220	HTSSOP (16)	5.00 mm x 4.40 mm

(1) For all available packages, see the orderable addendum at the end of the datasheet.

Figure 1. UCD8220 Typical Simplified Push-Pull Converter Application Schematic

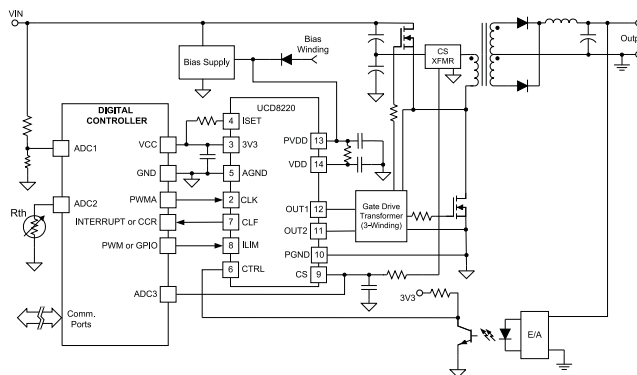

Table of Contents

1 Features	1	7.3 Feature Description.....	13
2 Applications	1	7.4 Device Functional Modes.....	17
3 Description	1	8 Application and Implementation	18
4 Revision History	2	8.1 Application Information.....	18
5 Pin Configuration and Functions	3	8.2 Typical Application	18
6 Specifications	4	9 Power Supply Recommendations	22
6.1 Absolute Maximum Ratings	4	10 Layout	23
6.2 ESD Ratings.....	4	10.1 Layout Guidelines	23
6.3 Recommended Operating Conditions.....	4	10.2 Layout Example	23
6.4 Thermal Information	4	10.3 Thermal Considerations.....	24
6.5 Electrical Characteristics.....	5	11 Device and Documentation Support	24
6.6 Timing Requirements	6	11.1 Documentation Support	24
6.7 Typical Characteristics	7	11.2 Trademarks	24
7 Detailed Description	12	11.3 Electrostatic Discharge Caution.....	24
7.1 Overview	12	11.4 Glossary	24
7.2 Functional Block Diagram	13	12 Mechanical, Packaging, and Orderable Information	24

4 Revision History

NOTE: Page numbers for previous revisions may differ from page numbers in the current version.

Changes from Revision D (October 2006) to Revision E	Page
• Added the following sections to the data sheet: <i>Device Functional Modes, Application Information, Design Requirements, Application Curves, Power Supply Recommendations, and Layout Example</i>	1
• Changed Updated ESD table	4
• Changed Junction temperature to 105 Celsius	5
• Changed Junction temperature to 105 Celsius	6
• Added Layout example for Industrial version	23

5 Pin Configuration and Functions

PWP Package
16-Pin HTSSOP With PowerPAD
Top View

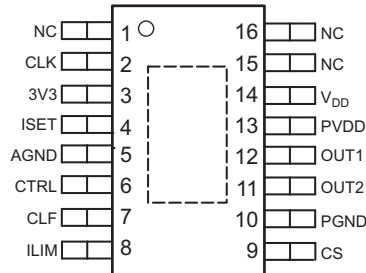

NC – No internal connection

Pin Functions

PIN		I/O	DESCRIPTION
NAME	NO.		
3V3	3	O	Regulated 3.3-V rail. The onboard linear voltage regulator is capable of sourcing up to 10 mA of current. Place a 0.22- μ F ceramic capacitor from this pin to analog ground.
AGND	5	—	Analog ground return
CLF	7	O	Current-limit flag. When the CS level is greater than the ILIM voltage minus 25 mV, the output driver is forced low and the current-limit flag (CLF) is set high. The CLF signal is latched high until the device receives the next rising edge on the CLK pin. This signal is also used for the start-up handshaking between the digital controller and the analog controller
CLK	2	I	Clock. Input pulse train contains operating frequency and maximum duty cycle limit. This pin is a high impedance digital input capable of accepting 3.3-V logic level signals up to 2 MHz. An internal Schmitt trigger comparator isolates the internal circuitry from any external noise.
CS	9	I	Current sense pin. A fast current-limit comparator connected to the CS pin is used to protect the power stage by implementing cycle-by-cycle current limiting.
CTRL	6	I	Input for the error feedback voltage from the external error amplifier. This input is multiplied by 0.5 and routed to the negative input of the PWM comparator
ILIM	8	I	Current-limit threshold set pin. The current-limit threshold can be set to any value between 0.25 V and 1 V. The default value while open is 0.5 V.
ISET	4	I	Pin for programming the current used to set the amount of slope compensation in peak current-mode control or to set the internal capacitor charging in voltage-mode control.
NC	1	—	No connection.
	15		
	16		
OUT1	12	O	The high-current TrueDrive integrated circuit driver output.
OUT2	11	O	The high-current TrueDrive integrated circuit driver output.
PGND	10	—	Power ground return. This pin should be connected close to the source of the power MOSFET.
PVDD	13	—	Supply pin provides power for the output drivers. This pin is not connected internally to the V _{DD} supply rail. The bypass capacitor for this pin should be returned to PGND.
V _{DD}	14	I	Supply input pin to power the control circuitry. Bypass the pin with a capacitor with a value of at least 4.7 μ F, returned to AGND.

6 Specifications

6.1 Absolute Maximum Ratings⁽¹⁾⁽²⁾

		MIN	MAX	UNIT
Supply voltage, V_{DD}			16	V
Supply current, I_{DD}	Quiescent		20	mA
	Switching, $T_A = 25^\circ\text{C}$, $T_J = 105^\circ\text{C}$, $V_{DD} = 12\text{ V}$		200	
Output gate-drive voltage, V_O	OUTx	-1	PVDD	V
Output gate-drive sink current, $I_{O(\text{sink})}$	OUTx		4	A
Output gate-drive source current, $I_{O(\text{source})}$	OUTx	-4		
Analog input	ISET, CS, CTRL, ILIM	-0.3	3.6	V
Digital I/Os	CLK, CLF	-0.3	3.6	
Continuous total power dissipation		See Thermal Information		
Operating junction temperature range, T_J		-55	150	$^\circ\text{C}$
Lead temperature (Soldering, 10 sec)			300	$^\circ\text{C}$
Storage temperature, T_{stg}		-65	150	$^\circ\text{C}$

- (1) Stresses beyond those listed under *absolute maximum ratings* may cause permanent damage to the device. These are stress ratings only, and functional operation of the device at these or any other conditions beyond those indicated under *recommended operating conditions* is not implied. Exposure to absolute-maximum-rated conditions for extended periods may affect device reliability.
- (2) All voltages are with respect to GND. Currents are positive into, negative out of the specified terminal.

6.2 ESD Ratings

			VALUE	UNIT
V_{ESD}	Electrostatic discharge	Human body model (HBM) ⁽¹⁾	± 2000	V
		Charged device model (CDM)	± 500	

- (1) Tested to JEDEC standard EIA/JESD22-A114-B specification.

6.3 Recommended Operating Conditions

over operating free-air temperature range (unless otherwise noted)

		MIN	MAX	UNIT
V_{DD}	Supply voltage, PVDD	4.5	15.5	V

6.4 Thermal Information

THERMAL METRIC ⁽¹⁾		PWP (HTSSOP)	UNIT
		16 PINS	
$R_{\theta JA}$	Junction-to-ambient thermal resistance	40.1	$^\circ\text{C}/\text{W}$
$R_{\theta JC(\text{top})}$	Junction-to-case (top) thermal resistance	29.5	
$R_{\theta JB}$	Junction-to-board thermal resistance	24.2	
Ψ_{JT}	Junction-to-top characterization parameter	1	
Ψ_{JB}	Junction-to-board characterization parameter	24	
$R_{\theta JC(\text{bot})}$	Junction-to-case (bottom) thermal resistance	1.8	

- (1) For more information about traditional and new thermal metrics, see the *IC Package Thermal Metrics* application report, [SPRA953](#).

6.5 Electrical Characteristics

$V_{DD} = 12\text{ V}$, 4.7- μF capacitor from V_{DD} to AGND, 1 μF from PVDD to PGND, 0.22- μF capacitor from 3V3 to AGND, $T_A = T_J = -40^\circ\text{C}$ to 105°C , (unless otherwise noted).

PARAMETER		TEST CONDITIONS	MIN	TYP	MAX	UNIT
SUPPLY SECTION						
Supply current, OFF		$V_{DD} = 4.2\text{ V}$		300	500	μA
Supply current, ON		Outputs not switching, CLK = low	2		3	mA
LOW VOLTAGE UNDERVOLTAGE LOCKOUT						
V_{DD} UVLO ON			4.25	4.5	4.75	V
V_{DD} UVLO OFF			4.05	4.25	4.45	V
V_{DD} UVLO hysteresis			150	250	350	mV
REFERENCE / EXTERNAL BIAS SUPPLY						
3V3 initial set point		$T_A = 25^\circ\text{C}$, $I_{LOAD} = 0$	3.267	3.3	3.333	V
3V3 set point over temperature			3.234	3.3	3.366	V
3V3 load regulation		$I_{LOAD} = 1\text{ mA}$ to 10 mA , $V_{DD} = 5\text{ V}$		1	6.6	mV
3V3 line regulation		$V_{DD} = 4.75\text{ V}$ to 12 V , $I_{LOAD} = 10\text{ mA}$		1	6.6	mV
Short circuit current		$V_{DD} = 4.75$ to 12 V	11	20	35	mA
3V3 OK threshold, ON		3.3 V rising	2.9	3.0	3.1	V
3V3 OK threshold, OFF		3.3 V falling	2.7	2.8	2.9	V
CLOCK INPUT (CLK)						
VIT+	HIGH, positive-going input threshold voltage		1.65		2.08	V
VIT-	LOW negative-going input threshold voltage		1.16		1.5	V
(VIT+) – (VIT-)	Input voltage hysteresis		0.6		0.8	V
Frequency		OUTX = 1 MHz			2	MHz
SLOPE COMPENSATION (ISET)						
ISET Voltage		V_{ISET} , 3V3 = 3.3 V, $\pm 2\%$	1.78	1.84	1.90	V
m	V_{SLOPE} (I-Mode)	$R_{ISET} = 6.19\text{ k}\Omega$ to AGND, CS = 0.25 V, CTRL = 2.5 V	1.48	2.12	2.76	$\text{V}/\mu\text{s}$
		$R_{ISET} = 100\text{ k}\Omega$ to AGND, CS = 0.25 V, CTRL = 2.5 V	0.099	0.142	0.185	
		$R_{ISET} = 499\text{ k}\Omega$ to AGND, CS = 0.25 V, CTRL = 2.5 V	0.019	0.028	0.037	
m	V_{SLOPE} (V-Mode)	$R_{ISET} = 4.99\text{ k}\Omega$ to 3V3, CTRL = 2.5 V	1.44	2.06	2.68	$\text{V}/\mu\text{s}$
		$R_{ISET} = 100\text{ k}\Omega$ to 3V3, CTRL = 2.5 V	0.079	0.114	0.148	
		$R_{ISET} = 402\text{ k}\Omega$ to 3v3, CTRL = 2.5 V	0.019	0.027	0.035	
ISET resistor range		Current mode control; R_{ISET} connected to AGND	6.19		499	$\text{k}\Omega$
ISET resistor range		Voltage mode control; R_{ISET} connected to 3V3	4.99		402	$\text{k}\Omega$
ISET current range		Voltage mode control with Feed-Forward; R_{ISET} connected to VIN	3.7		300	μA
PWM						
PWM offset at CTRL input		3V3 = 3.3 V $\pm 2\%$	0.45	0.51	0.6	V
CTRL buffer gain ⁽¹⁾		Gain from CTRL to PWM comparator input		0.5		V/V

(1) Specified by design. Not 100% tested in production.

Electrical Characteristics (continued)

$V_{DD} = 12\text{ V}$, 4.7- μF capacitor from V_{DD} to AGND, 1 μF from PVDD to PGND, 0.22- μF capacitor from 3V3 to AGND, $T_A = T_J = -40^\circ\text{C}$ to 105°C , (unless otherwise noted).

PARAMETER	TEST CONDITIONS	MIN	TYP	MAX	UNIT
CURRENT LIMIT (ILIM)					
ILIM internal current limit threshold	ILIM = OPEN	0.466	0.5	0.536	V
ILIM maximum current limit threshold	ILIM = 3.3 V	0.975	1.025	1.075	V
ILIM current limit threshold	ILIM = 0.75 V	0.700	0.725	0.750	V
ILIM minimum current limit threshold	ILIM = 0.25 V	0.2	0.23	0.25	V
CLF output high level	CS > ILIM, $I_{LOAD} = -7\text{ mA}$	2.64			V
CLF output low level	CS \leq ILIM, $I_{LOAD} = 7\text{ mA}$				0.66 V
CURRENT SENSE COMPARATOR					
Bias voltage	Includes CS comp offset	5	25	50	mV
Input bias current		-1			μA
CURRENT SENSE DISCHARGE TRANSISTOR					
Discharge resistance	CLK = low, resistance from CS to AGND	10	35	75	Ω
OUTPUT DRIVERS					
Source current ⁽¹⁾	$V_{DD} = 12\text{ V}$, CLK = high, OUTx = 5 V	4			A
Sink current ⁽¹⁾	$V_{DD} = 12\text{ V}$, CLK = low, OUTx = 5 V	4			A
Source current ⁽¹⁾	$V_{DD} = 4.75\text{ V}$, CLK = high, OUTx = 0	2			A
Sink current ⁽¹⁾	$V_{DD} = 4.75\text{ V}$, CLK = low, OUTx = 4.75 V	3			A
Output with $V_{DD} < UVLO$	$V_{DD} = 1.0\text{ V}$, $I_{SINK} = 10\text{ mA}$	0.8		1.2	V

6.6 Timing Requirements

$V_{DD} = 12\text{ V}$, 4.7- μF capacitor from V_{DD} to AGND, 1 μF from PVDD to PGND, 0.22- μF capacitor from 3V3 to AGND, $T_A = T_J = -40^\circ\text{C}$ to 105°C , (unless otherwise noted).

		MIN	NOM	MAX	UNIT	
CLOCK INPUT (CLK)						
Minimum allowable off time ⁽¹⁾		20			ns	
CURRENT LIMIT (ILIM)						
Propagation delay from CLK to CLF	CLK rising to CLF falling after a current limit event	15		25	ns	
CURRENT SENSE COMPARATOR						
Propagation delay from CS to OUTx	ILIM = 0.5 V, measured on OUTx, CS = threshold + 60 mV	25		40	ns	
Propagation delay from CS to CLF	ILIM = 0.5 V, measured on CLF, CS = threshold + 60 mV	25		50		
OUTPUT DRIVERS						
t_R	Rise time	$C_{LOAD} = 2.2\text{ nF}$, $V_{DD} = 12\text{ V}$, See Figure 2		10	20	ns
t_F	Fall time	$C_{LOAD} = 2.2\text{ nF}$, $V_{DD} = 12\text{ V}$, See Figure 2		10	15	
t_{D1}	Propagation delay from CLK to OUTx, CLK rising	$C_{LOAD} = \text{open}$, $V_{DD} = 12\text{ V}$, See Figure 2		25	35	ns
t_{D2}	Propagation delay from CLK to OUTx, CLK falling	$C_{LOAD} = \text{open}$, $V_{DD} = 12\text{ V}$, See Figure 2		25	35	

(1) Specified by design. Not 100% tested in production.

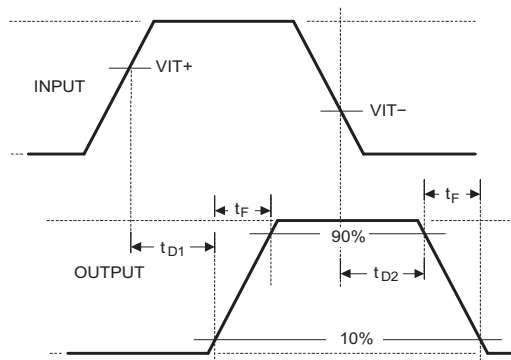

Figure 2. Timing Diagram

6.7 Typical Characteristics

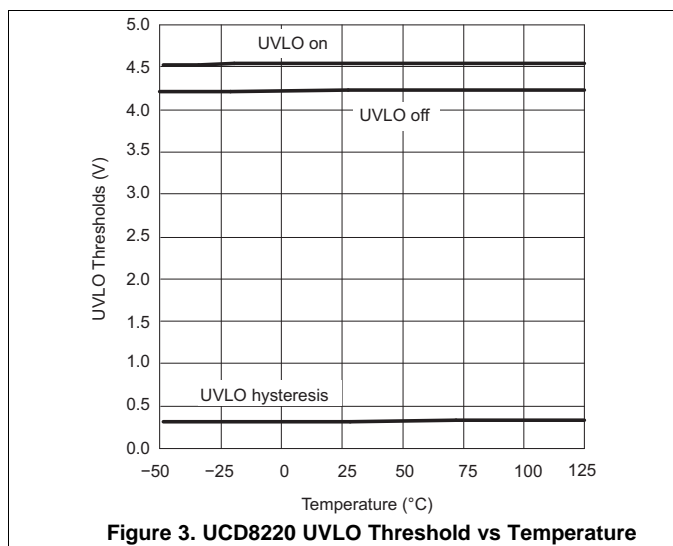

Figure 3. UCD8220 UVLO Threshold vs Temperature

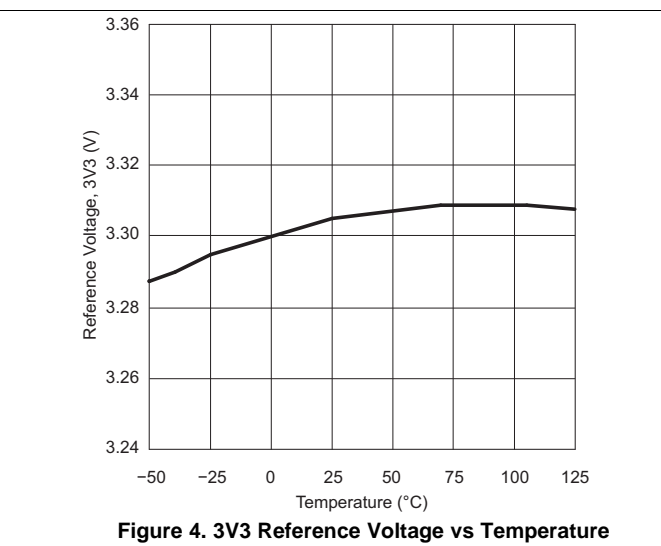

Figure 4. 3V3 Reference Voltage vs Temperature

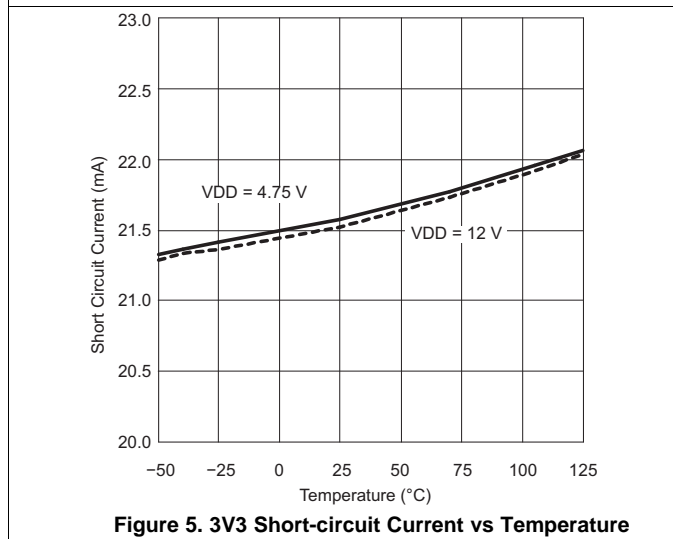

Figure 5. 3V3 Short-circuit Current vs Temperature

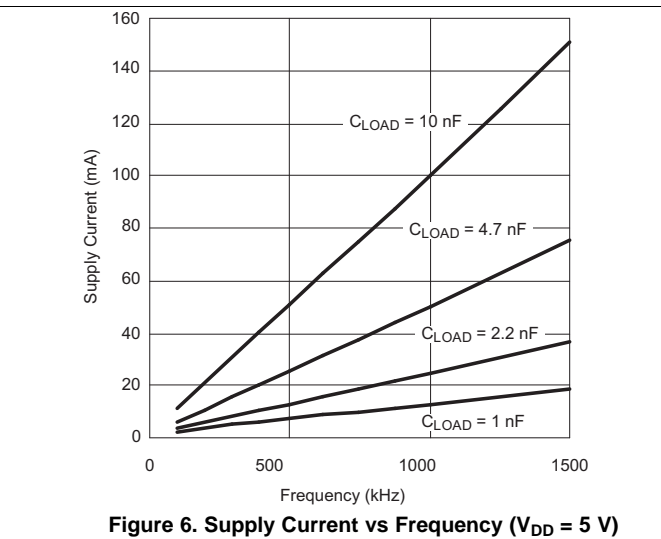

Figure 6. Supply Current vs Frequency ($V_{DD} = 5\text{ V}$)

Typical Characteristics (continued)

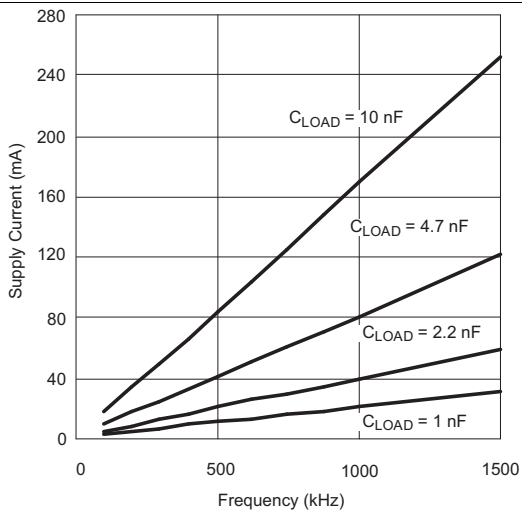

Figure 7. Supply Current vs Frequency ($V_{DD} = 8\text{ V}$)

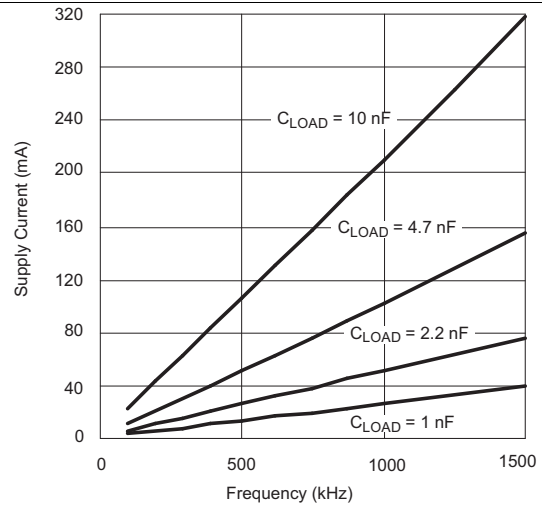

Figure 8. Supply Current vs Frequency ($V_{DD} = 10\text{ V}$)

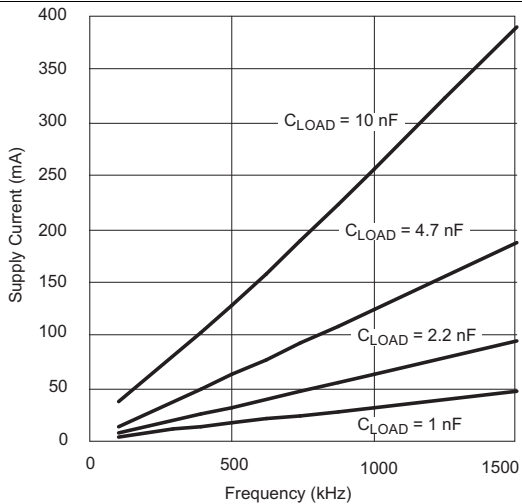

Figure 9. Supply Current vs Frequency ($V_{DD} = 12\text{ V}$)

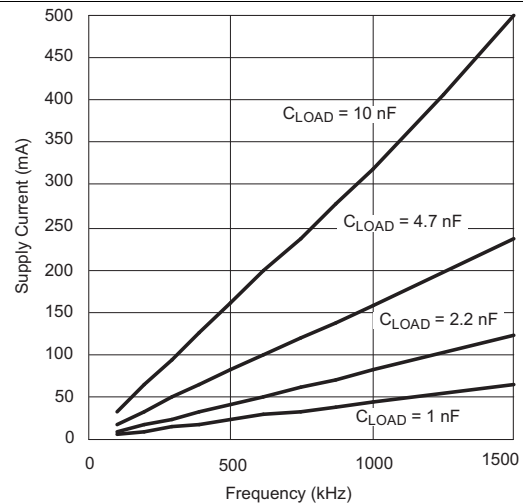

Figure 10. Supply Current vs Frequency ($V_{DD} = 15\text{ V}$)

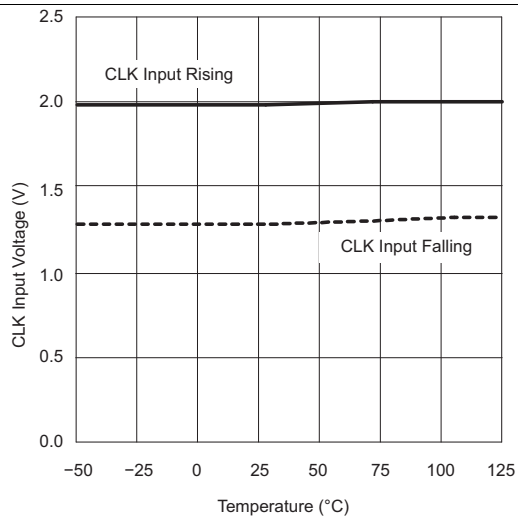

Figure 11. CLK Input Threshold vs Temperature

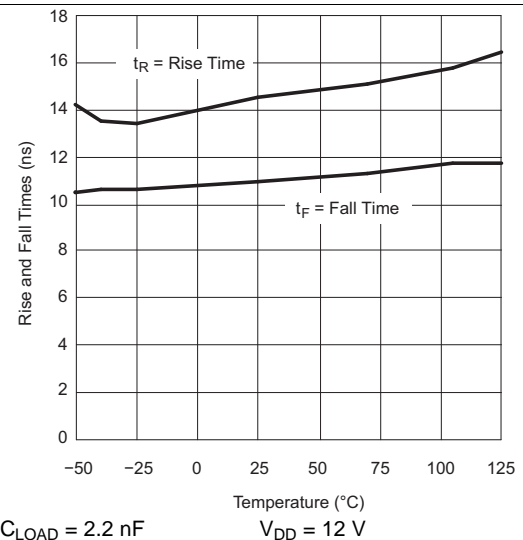

Figure 12. Output Rise Time and Fall Time vs Temperature

Typical Characteristics (continued)

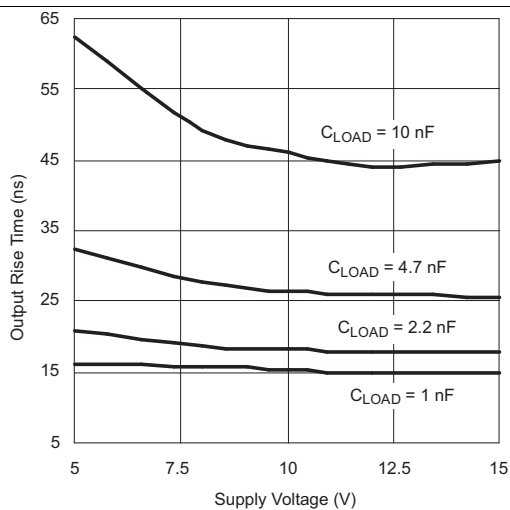

Figure 13. Output Rise Time vs Supply Voltage

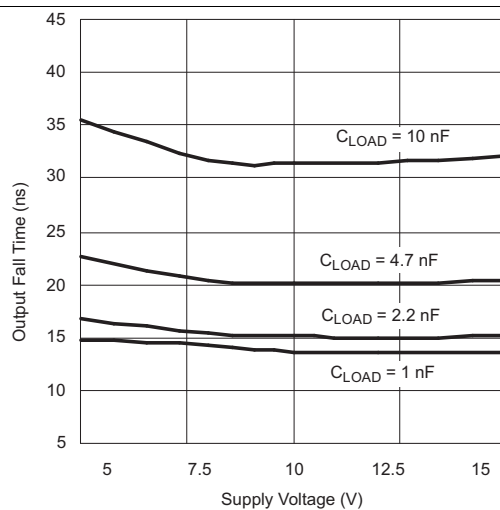

Figure 14. Output Fall Time vs Supply Voltage

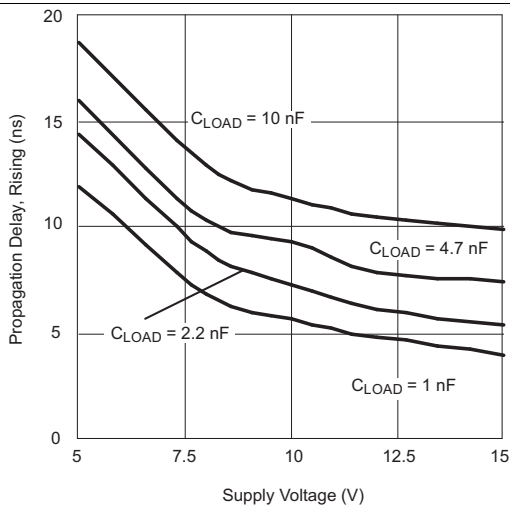

Figure 15. CLK to OUTx Propagation Delay Rising vs Supply Voltage

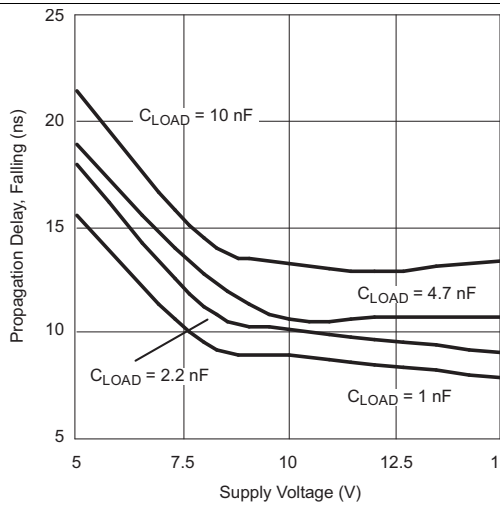

Figure 16. CLK to OUTx Propagation Delay Falling vs Supply Current

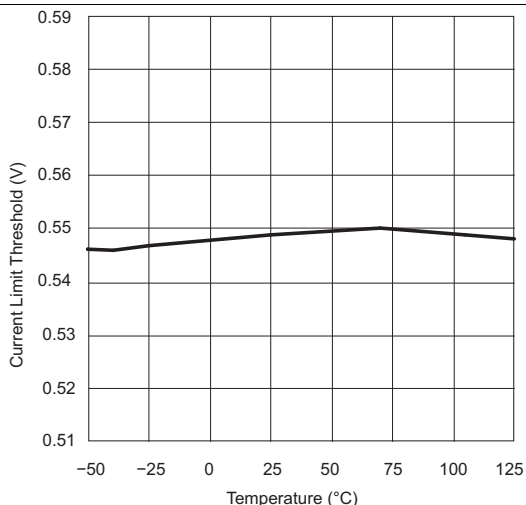

Figure 17. Default Current Limit Threshold vs Temperature

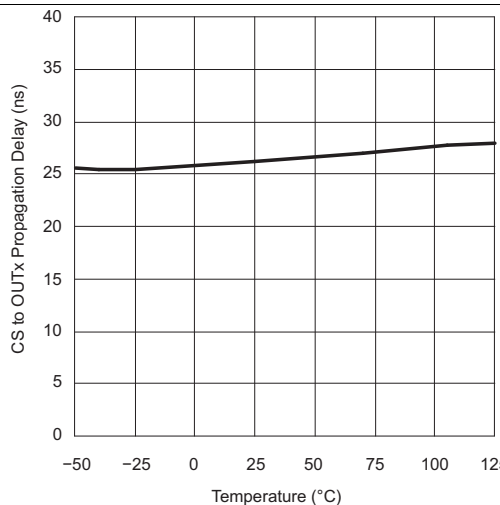

Figure 18. CS to OUTx Propagation Delay vs Temperature

Typical Characteristics (continued)

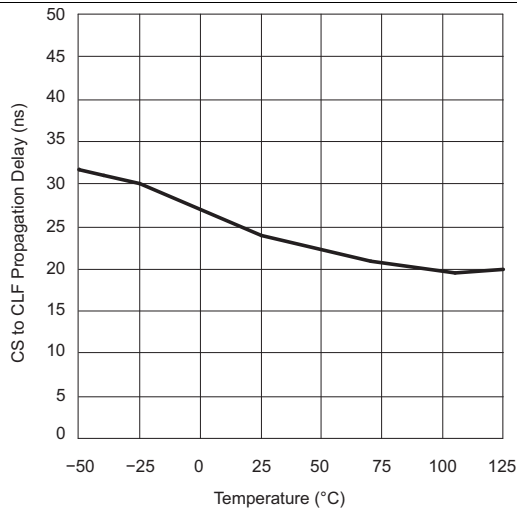

Figure 19. CS to CLF Propagation Delay vs Temperature

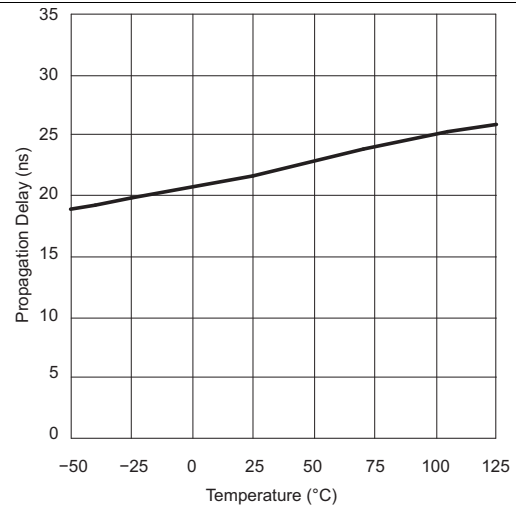
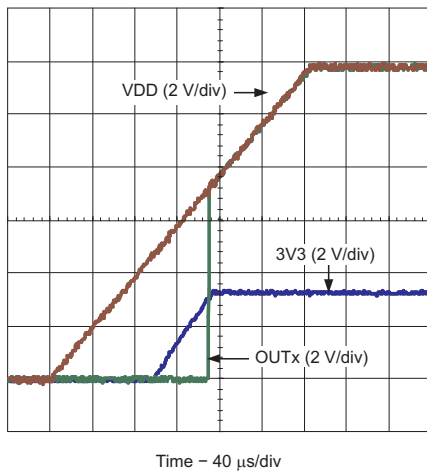
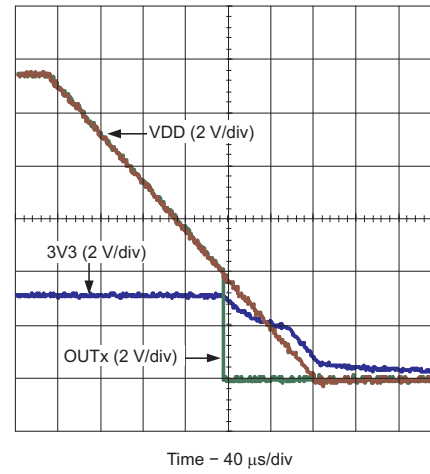

Figure 20. CLK to OUT Propagation Delay vs Temperature



CLK = CTRL = 3V3

Figure 21. Start-Up Behavior at $V_{DD} = 12\text{ V}$



CLK = CTRL = 3V3

Figure 22. Shut-Down Behavior at $V_{DD} = 12\text{ V}$

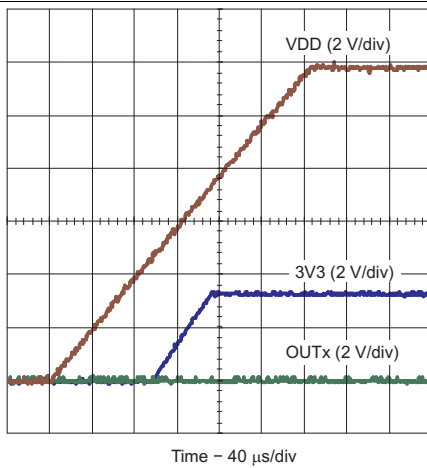

CLK = AGND

CTRL = 3V3

Figure 23. Start-Up Behavior at $V_{DD} = 12\text{ V}$

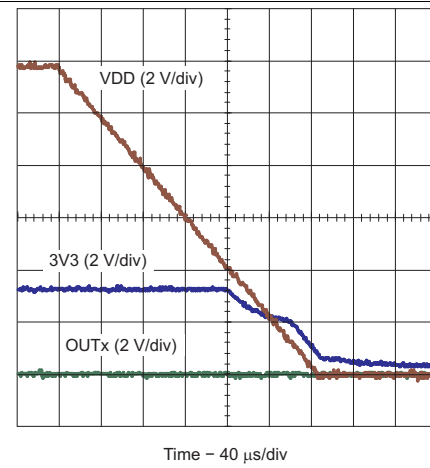

CLK = AGND

CTRL = 3V3

Figure 24. Shut-Down Behavior at $V_{DD} = 12\text{ V}$

Typical Characteristics (continued)

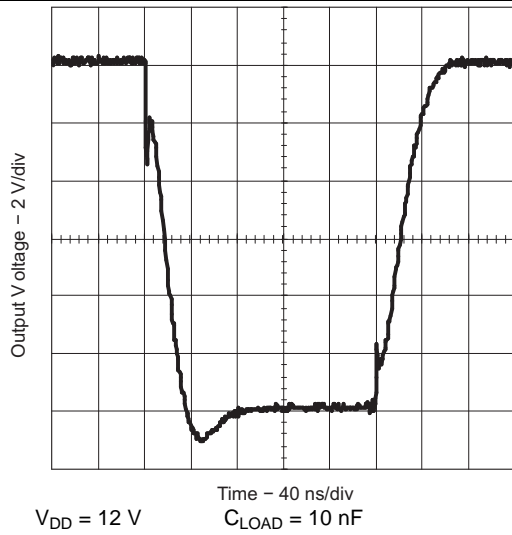

Figure 25. Output Rise and Fall Time

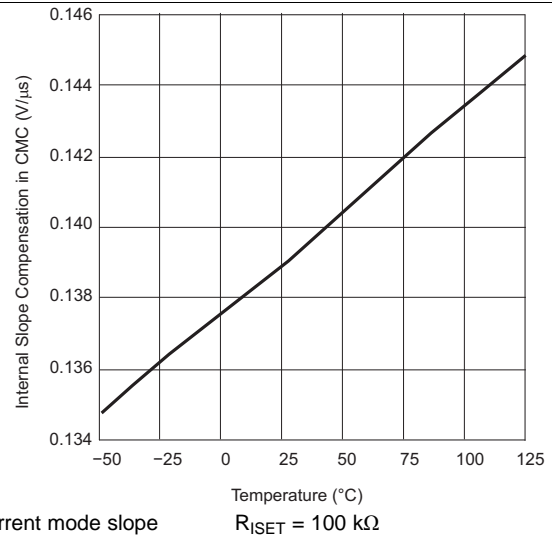

Figure 26. Internal Slope Compensation in CMC vs Temperature

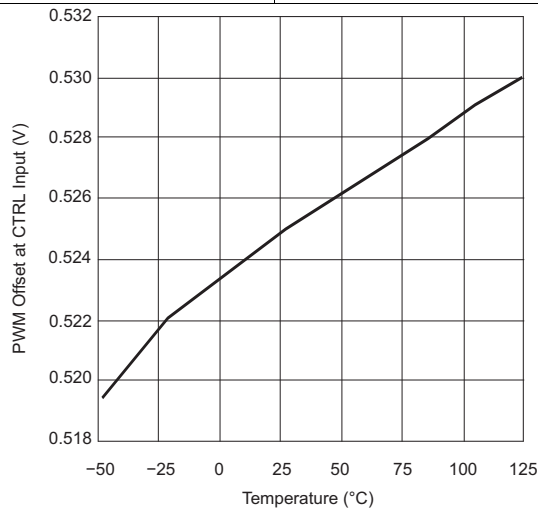

Figure 27. PWM Offset at CTRL Input vs Temperature

7 Detailed Description

7.1 Overview

The UCD8220 device is a digitally managed analog PWM controller that is configured with push-pull drive logic.

In systems using the UCD8220 device, the PWM feedback loop is closed using the traditional analog methods. However, the UCD8220 includes circuitry to interpret a time-domain digital pulse train from a digital controller. The pulse train contains the operating frequency and maximum duty-cycle limit and therefore controls the power supply operation. The device circuitry eases the implementation of a converter with high-level control features without the added complexity or digital PWM-resolution limitations encountered when closing the voltage control-loop in the discrete time domain.

The UCD8220 device can be configured for either peak current-mode or voltage-mode control. The device provides a programmable current-limit function and a digital output current limit flag which can be monitored by the host controller. For fast switching speeds, the output stages use the TrueDrive output-circuit architecture, which delivers rated current of ± 4 -A into the gate of a MOSFET during the Miller plateau region of the switching transition. Finally the device also includes a 3.3-V, 10-mA linear regulator to provide power for the digital controller.

The UCD8220 device includes circuitry and features to ease implementing a converter that is managed by a microcontroller or a digital signal processor. Digitally managed power supplies provide software programmability and monitoring capability of the operation of the power supply, including:

- Switching frequency
- Synchronization
- D_{MAX}
- $V \times S$ clamp
- Input UVLO start and stop voltage
- Input OVP start and stop voltage
- Soft-start profile
- Current-limit operation
- Shutdown
- Temperature shutdown

7.2 Functional Block Diagram

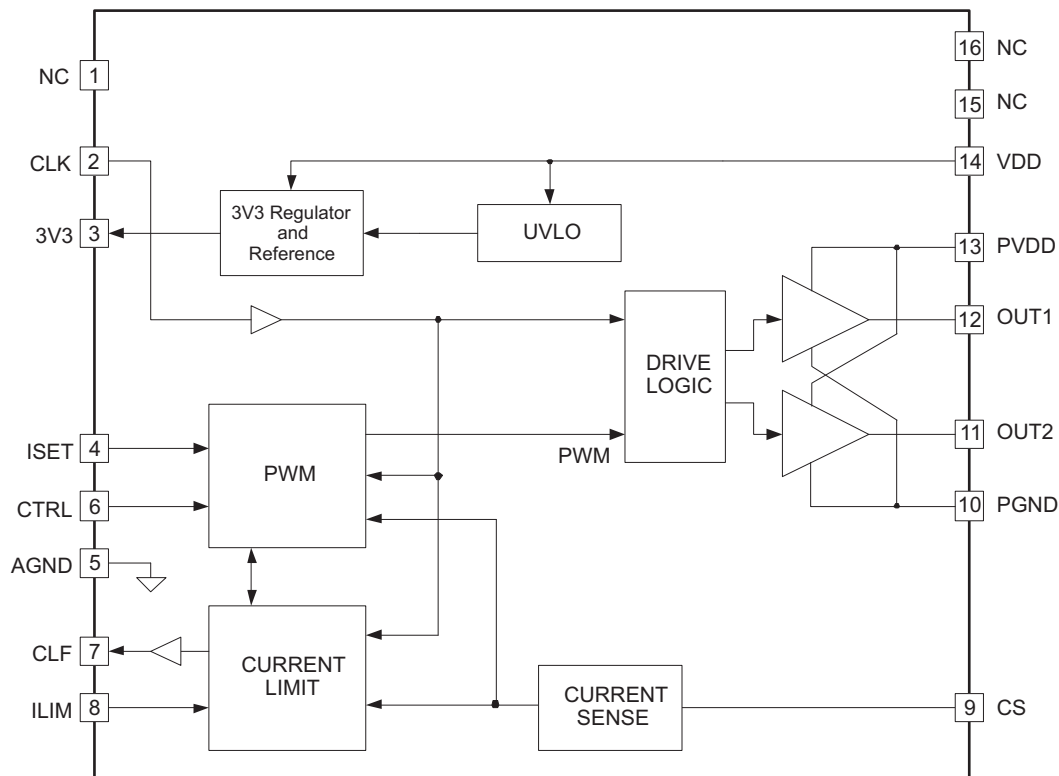

7.3 Feature Description

7.3.1 CLK Input Time-Domain Digital Pulse Train

While the loop is closed in the analog domain, the UCD8220 device is managed by a time-domain digital pulse train from a digital controller. The pulse train, shown as CLK in Figure 28, contains the operating frequency and maximum duty-cycle limit and therefore controls the power supply operation as previously listed. The pulse train uses a Texas Instruments communication protocol which is a proprietary communication system that provides control of the power supply operation through software programming. The rising edge of the CLK signal represents the switching frequency. Figure 28 depicts the operation of the UCD8220 device in one of five modes. At the time when the internal signal *REF OK* is low, the UCD8220 device is not ready to accept CLK inputs. When the *REF OK* signal goes high, then the device is ready to process inputs. While the CLK input is low, the outputs are disabled and the CLK signal is used as an enable input. When the digital controller completes the initialization routine and verifies that all voltages are within operating range, then the controller begins the soft-start procedure by slowly ramping up the duty cycle of the CLK signal, while maintaining the desired switching frequency. The CLK duty cycle continues to increase until it reaches steady-state where the analog control loop takes over and regulates the output voltage to the desired set point. During steady state, the duty cycle of the CLK pulse can be set using a volt-second product calculation to protect the primary of the power transformer from saturation during transients.

When the power supply detects an overcurrent event, it enters the current-limit mode where the outputs are quickly turned off and the CLF signal is set high to notify the digital controller that the last power pulse was truncated. This technique is beneficial because it allows the digital controller to decide how to handle this overcurrent event while providing some protection to the other components being supplied by this device.

Feature Description (continued)

The software is now in charge of the response to overcurrent events. In typical analog designs, the power supply response to overcurrent is hardwired in the silicon. With this method, the user can configure the response differently for different applications. For example, the software can be configured to latch-off the power supply in response the first overcurrent event, or to allow a fixed number of current-limit events, so that the supply is capable of starting up into a capacitive load. The user can also configure the supply to enter into *hiccup* mode immediately or after a certain number of current-limit events. As described later in this data sheet, the current limit threshold can be varied in time to create unique current limit profiles. For example, the current limit set point can be set high for a predefined number of cycles to blow a manual fuse, and can be reduced down to protect the system in the event of a faulty fuse.

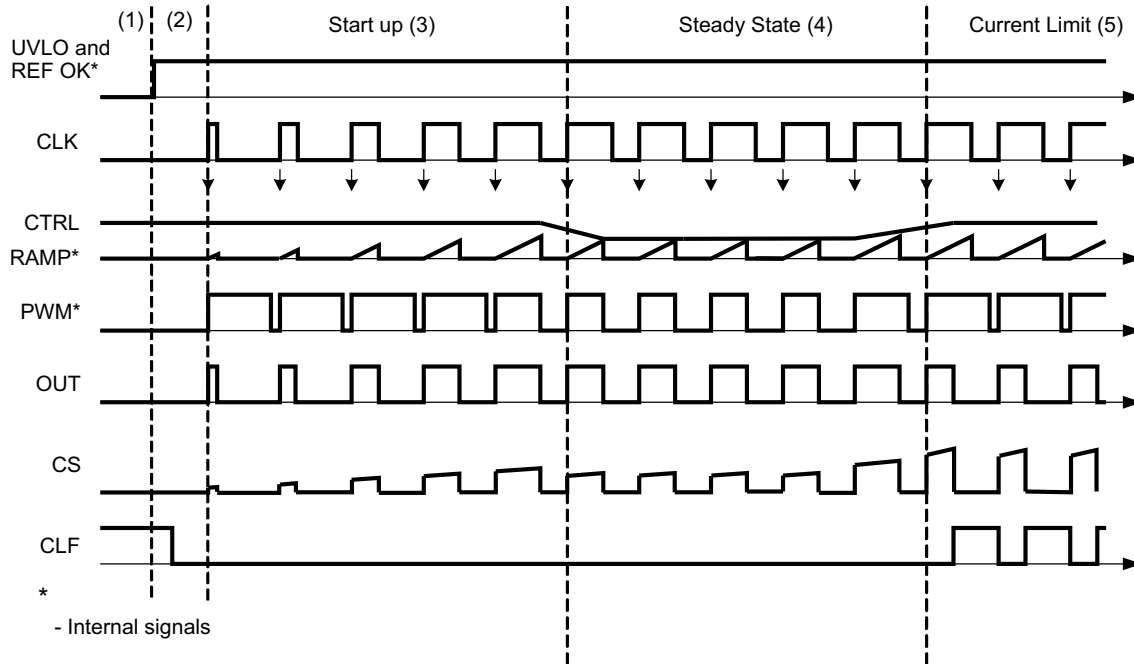
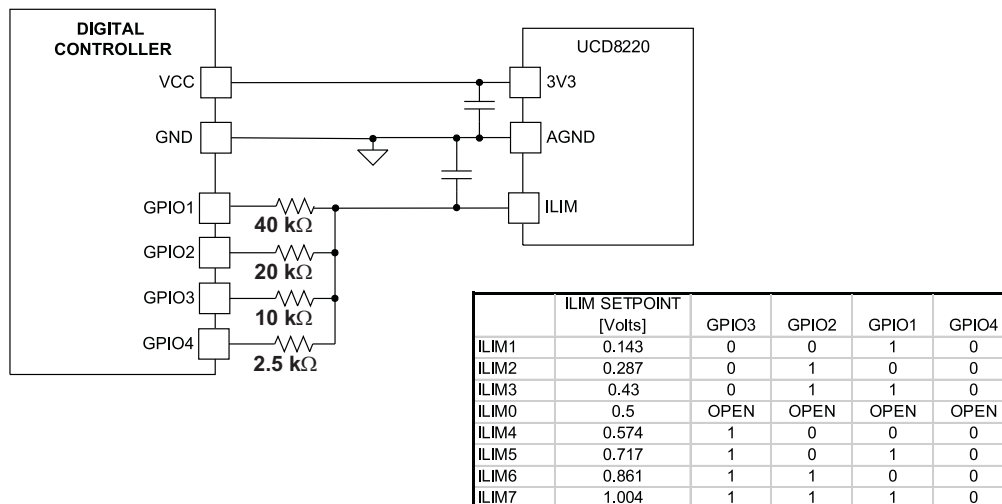

Figure 28. Timing and Circuit Operation Diagram

7.3.2 Current Sensing and Protection

a) GPIO outputs



b) PWM output

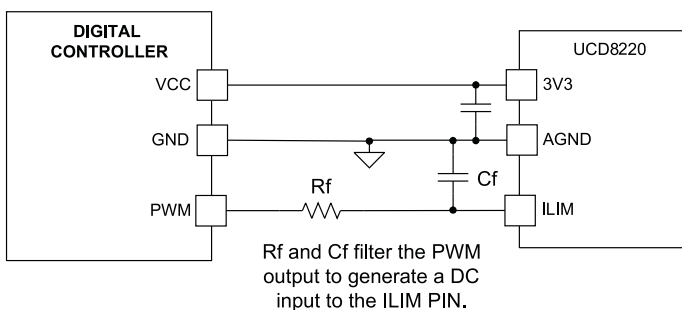

c) Resistor divider

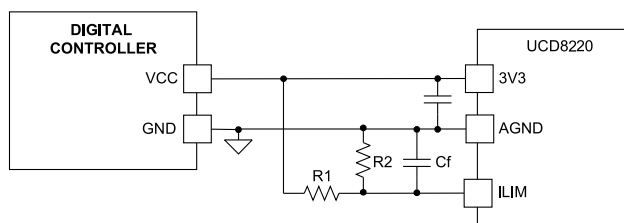

d) internal set point

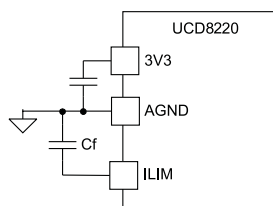

Figure 29. ILIM Settings

7.3.3 Handshaking

The UCD8220 device has a built-in handshaking feature to facilitate efficient start-up of the digitally managed power supply. At start-up the CLF flag is held high until all the internal and external supply voltages of the UCD8220 device is within its operating range. When the supply voltages are within acceptable limits, the CLF flag goes low and the device processes the CLK signals. The digital controller should monitor the CFL flag at start-up and wait for the CLF flag to go low before sending CLK pulses to the UCD8220 device.

7.3.4 Driver Output

The high-current output stage of the UCD8220 device is capable of supplying $\pm 4\text{-A}$ peak current pulses and swings to both the PVDD and PGND pins.

The drive output uses the TI's TrueDrive output-circuit architecture, which delivers rated current into the gate of a MOSFET when it is most needed, during the Miller plateau region of the switching transition providing efficiency gains.

The TrueDrive integrated circuit consists of pullup and pulldown circuits with bipolar and MOSFET transistors in parallel. The peak output current rating is the combined current from the bipolar and MOSFET transistors. This hybrid output stage also allows efficient current sourcing at low supply voltages.

7.3.5 Source and Sink Capabilities During Miller Plateau

Large power MOSFETs present a large load to the control circuitry. Proper drive is required for efficient, reliable operation. The UCD8220 driver has been optimized to provide maximum drive to a power MOSFET during the Miller plateau region of the switching transition. This interval occurs while the drain voltage is swinging between the voltage levels dictated by the power topology, requiring the charging or discharging of the drain-gate capacitance with current supplied or removed by the driver device. See (5) in the [Related Documentation](#) section.

7.3.6 Drive Current and Power Requirements

The UCD8220 device contains drivers that can deliver high current into a MOSFET gate for a period of several hundred nanoseconds. High-peak current is required to turn on a MOSFET. To turn off a MOSFET, the driver is required to sink a similar amount of current to ground. This cycle repeats at the operating frequency of the power device.

For additional information on the current required to drive a power MOSFET and other capacitive-input switching devices, see (5) in the [Related Documentation](#) section.

When a driver device is tested with a discrete, capacitive load, calculating the power that is required from the bias supply is fairly simple. Use [Equation 1](#) to calculate the energy that must be transferred from the bias supply to charge the capacitor.

$$E = \frac{1}{2} \times CV^2$$

where

- C is the load capacitor
 - V is the bias voltage feeding the driver
- (1)

An equal amount of energy is transferred to ground when the capacitor is discharged. This transfer of energy results in a power loss which is calculated with [Equation 2](#).

$$P = CV^2 \times f$$

where

- f is the switching frequency
- (2)

This power is dissipated in the resistive elements of the circuit. Thus, with no external resistor between the driver and gate, this power is dissipated inside the driver. Half of the total power is dissipated when the capacitor is charged, and the other half is dissipated when the capacitor is discharged.

Use Equation 3 to calculate the power loss with the following values: $V_{DD} = 12\text{ V}$, $C_{LOAD} = 2.2\text{ nF}$, and $f = 300\text{ kHz}$.

$$P = 2.2\text{ nF} \times 12^2 \times 300\text{ kHz} = 0.095\text{ W} \tag{3}$$

Use Equation 4 to calculate the current with a 12-V supply.

$$I = \frac{P}{V} = \frac{0.095\text{ W}}{12\text{ V}} = 7.9\text{ mA} \tag{4}$$

7.3.7 Clearing the Current-Limit Flag (CLF)

In the UCD8220 design, the CLF signal is cleared by the comparator (compares the voltage between the CS and ILIM pins) output. However, the comparator output is enabled by the OUTx pin. Therefore, the CLF signal does not clear (go low) unless one or both OUTx pins are on, which enables the comparator output. Pulling the CTRL pin high turns the OUTx pin on which is why the CLF flag only clears when CTRL is high (greater than 0.45 to 0.6 V). Therefore, anything that turns on the OUTs pins enables the comparator, and if V_{CS} is less than V_{ILIM} , the comparator output clears the CLF signal. The CLF signal goes low during the next rising edge on the CLK pin after these conditions are met.

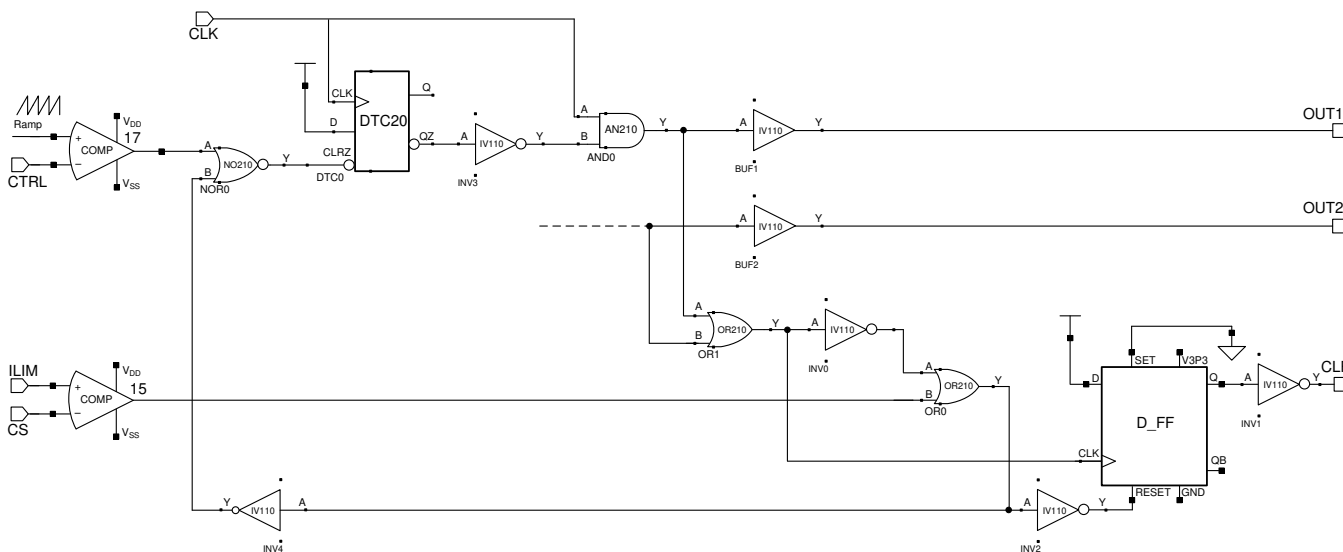

Figure 30. Logic Circuit for CLF

7.4 Device Functional Modes

The device has no additional functional modes.

8 Application and Implementation

NOTE

Information in the following applications sections is not part of the TI component specification, and TI does not warrant its accuracy or completeness. TI's customers are responsible for determining suitability of components for their purposes. Customers should validate and test their design implementation to confirm system functionality.

8.1 Application Information

The UCD8220 device can be configured for either peak current mode or voltage mode control. The device can be used to implement a variety of applications such as push-pull, half-bridge, or full-bridge converter.

8.2 Typical Application

Using the UCD8220 device in an application, a high degree of digital control can be achieved because the device integrates the PWM, logic, error amplifier, current limit, and drivers. In addition, the on-chip regulator provides power to the microcontroller. An example application is using the device in half-bridge power topology.

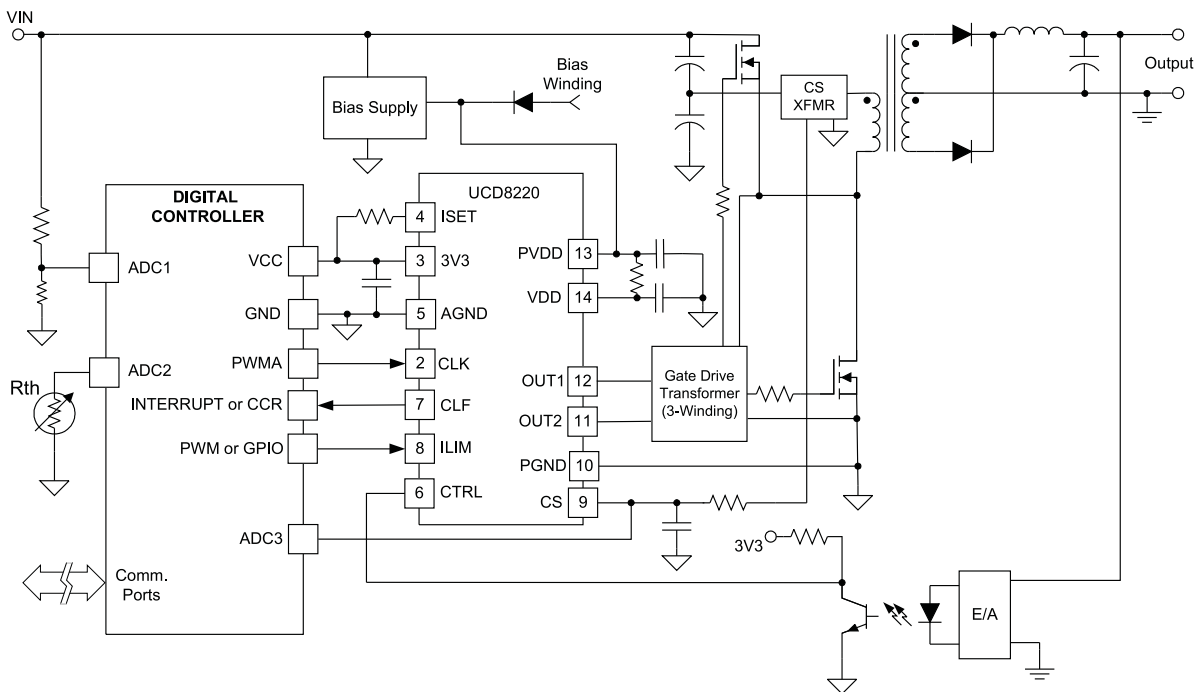

Figure 31. UCD8220 Typical Simplified Half-Bridge Converter Application Schematic

8.2.1 Design Requirements

When designing a half-bridge system, the key requirement is determining which functions should remain in the digital domain rather than the analog domain. The design shown in allows for a high degree of control over various blocks such as PWM, logic, error amplifier, current limit, and drivers. The UCD8220 closes the control loop for the power supply and provides the loop compensation. During operation, the UCD8220 monitors current and terminates the switching cycle safely if the value exceeds the current limit. By performing this task in the UCD8220, the device assists in real-time and full-time safety. The UCD8220 device provides notification of overcurrent events to the microcontroller. The notification of overcurrent events to the microcontroller allows the microcontroller to have a more complex response strategy. The firmware can, for example, direct the system to tolerate a finite number of current events, go to soft-stop, or shut down.

Typical Application (continued)

8.2.2 Detailed Design Procedure

Current limit is set through a simple resistor divider at the ISET pin. In the case of an overcurrent limit, the UCD8220 device sets the current flag (CF) pin high and the device is turned off by the host controller if the current limit exceeds a certain number of cycles. Depending upon the control method, the ISET resistor can be selected as previously mentioned.

8.2.2.1 Selecting the ISET Resistor for Voltage Mode Control

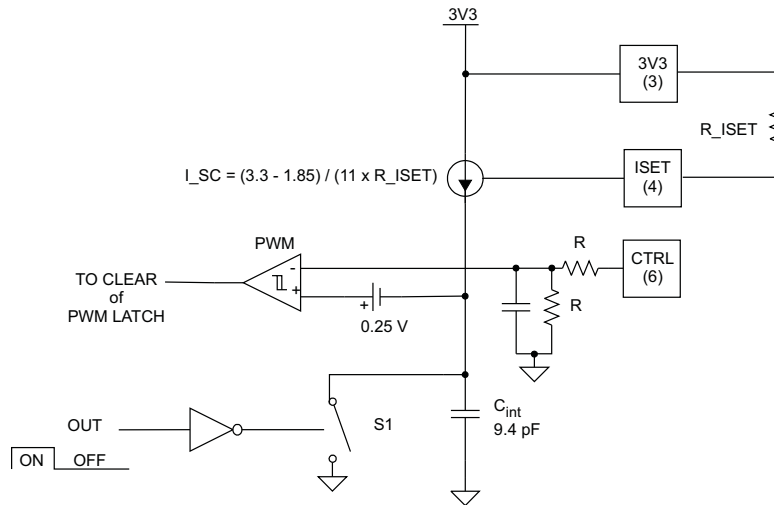

Figure 32. UCD8220 Configured in Voltage Mode Control With an Internal Timing Capacitor

When the ISET resistor is configured as shown in Figure 32 with the ISET resistor connected between the ISET pin and the 3V3 pin, the device is set up for voltage mode control. For purposes of voltage loop compensation the, voltage ramp is 1.4 V from the valley to the peak. Use Equation 5 to calculate the proper resistance for a desired clock frequency.

$$R_{ISET} = \frac{(3.3 - 1.85) \times 10^{12}}{11 \times 1.4 \times f_{clk} \times 9.4} \Omega$$

where

- fclk = desired clock frequency in Hz (5)

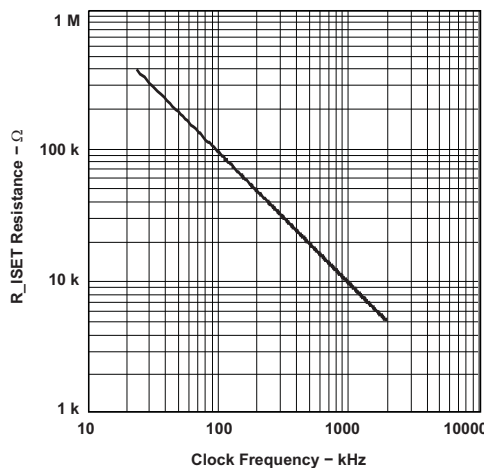

Figure 33. ISET Resistance Versus Clock Frequency

Typical Application (continued)

Figure 33 shows the nominal value of resistance to use for a desired clock frequency. For example, a clock frequency of 1000 kHz will require 10 kΩ of the ISET resistor. The UCD8220 device has two outputs controlled by push-pull logic and therefore the output ripple frequency is equal to the clock frequency and each output switches at half the clock frequency.

8.2.2.2 Selecting the ISET Resistor for Voltage Mode Control with Voltage Feed Forward

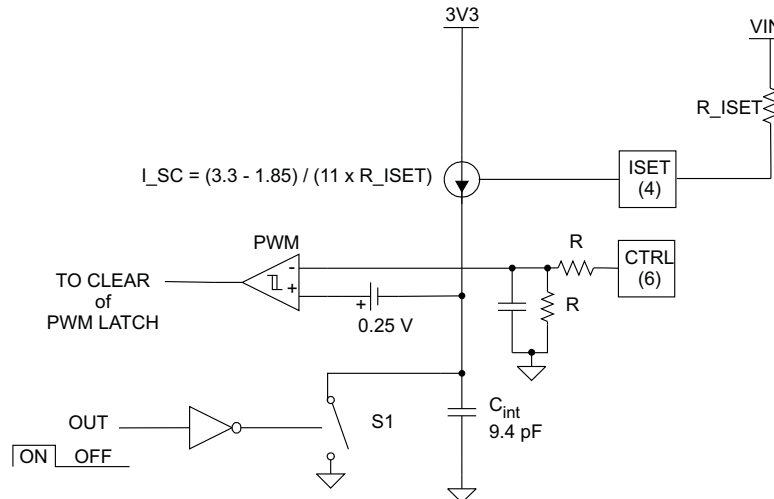

Figure 34. UCD8220 Configured in Voltage Mode Control with Voltage Feed Forward

When the ISET resistor is configured as shown in Figure 34 with the ISET resistor connected between the ISET pin and the input voltage, VIN, the device is configured for voltage mode control with voltage feed forward. For the purposes of voltage loop compensation, the voltage ramp is $1.4 \text{ V} \times \text{VIN} / \text{VIN}_{\text{max}}$ from the valley to the peak. Use Equation 6 to calculate the proper resistance for a desired clock frequency and input voltage range.

$$R_{\text{ISET}} = \frac{(\text{Vin}_{\text{max}} - 1.85) \times 10^{12}}{11 \times 1.4 \times \text{fclk} \times 9.4} \Omega$$

where

- fclk = Desired Clock Frequency in Hz (6)

For a general discussion of the benefits of voltage mode control with voltage feed forward, see (5) in the [Related Documentation](#) section.

Typical Application (continued)

8.2.2.3 Selecting the ISET Resistor for Peak Current Mode Control with Internal Slope Compensation

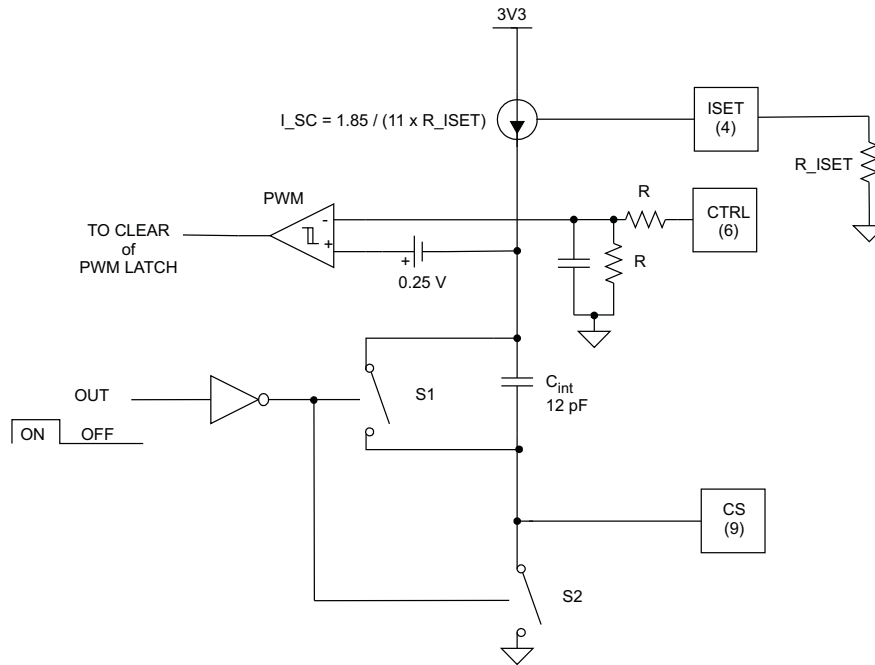

Figure 35. UCD8220 Configured in Peak Current Control with Internal Slope Compensation

When the ISET resistor is configured as shown in Figure 35 with the ISET resistor connected between the ISET pin and the AGND pin, the device is configured for peak current-mode control with internal slope compensation. The voltage at the ISET pin is 1.85 V so the internal slope compensation current, I_{SC}, being fed into the internal slope compensation capacitor is equal to 1.85 / (11 × R_{ISET}). Use Equation 7 to calculate the voltage slope at the PWM comparator input which is generated by this current.

$$\text{SLOPE} = \frac{1.85 \times 10^6}{11 \times R_{\text{ISET}} \times 12} \text{ V}/\mu\text{s} \tag{7}$$

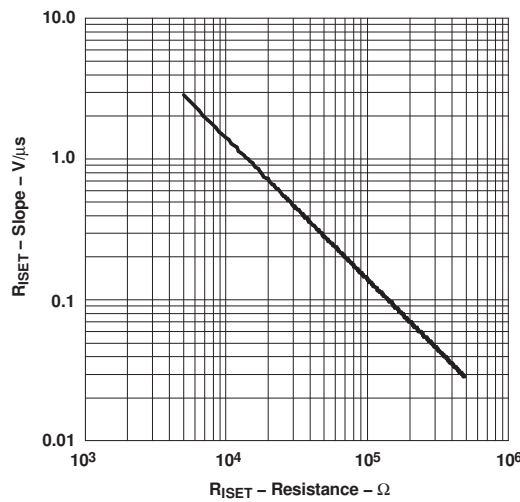
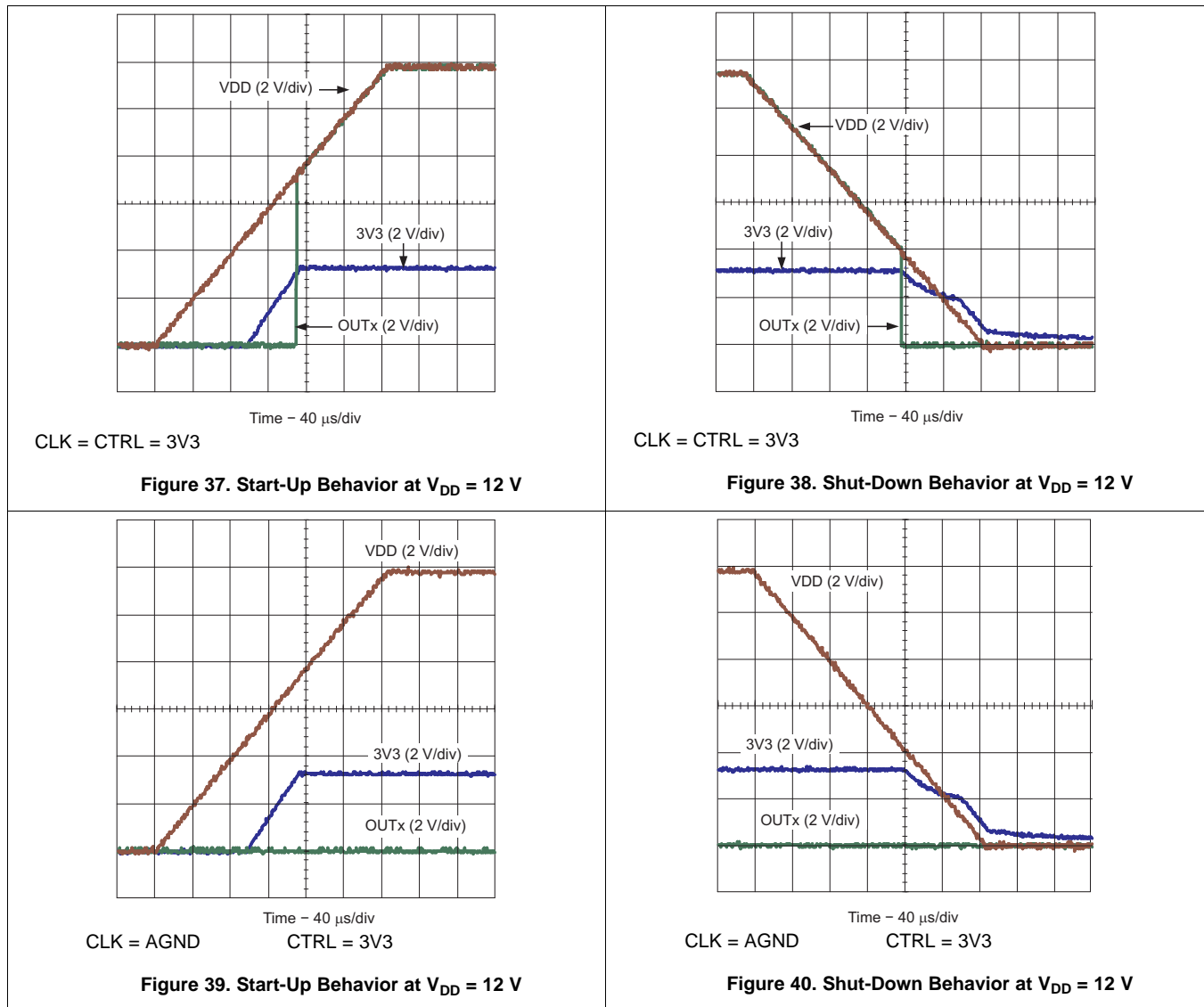

Figure 36. Slope vs R_ISET Resistance

Typical Application (continued)

The amount of slope compensation required depends on the design of the power stage and the output specifications. A general rule is to add an up-slope equal to the down slope of the output inductor. Refer to (1) and (8) in the [Related Documentation](#) section for a more detailed discussion regarding slope compensation in peak current mode controlled power stages.

8.2.3 Application Curves



9 Power Supply Recommendations

The UCD8220 device operates from an input supply voltage range from 4.5 V to 15.5 V. Ensure that the power supply rail is clean and uses high quality ceramic decoupling capacitors.

10 Layout

10.1 Layout Guidelines

In a MOSFET driver operating at high frequency, minimizing stray inductance to minimize overshoot, undershoot, and ringing is critical. The low output impedance of the drivers produces waveforms with high di/dt which tends to induce ringing in the parasitic inductances. Connecting the driver device close to the MOSFETs is advantageous. To reduce ringing, minimize the trace inductance from OUT 1 and OUT 2 to the MOSFET input. Connecting the PGND and AGND pins to the PowerPAD integrated circuit package with a thin trace is recommended. Ensuring that the voltage potential between these two pins does not exceed 0.3 V is critical. The use of schottky diodes on the outputs to the PGND and PVDD pins is recommended when driving gate transformers. See (3) in the [Related Documentation](#) section for a description of proper pad layout for the PowerPAD integrated circuit package.

10.2 Layout Example

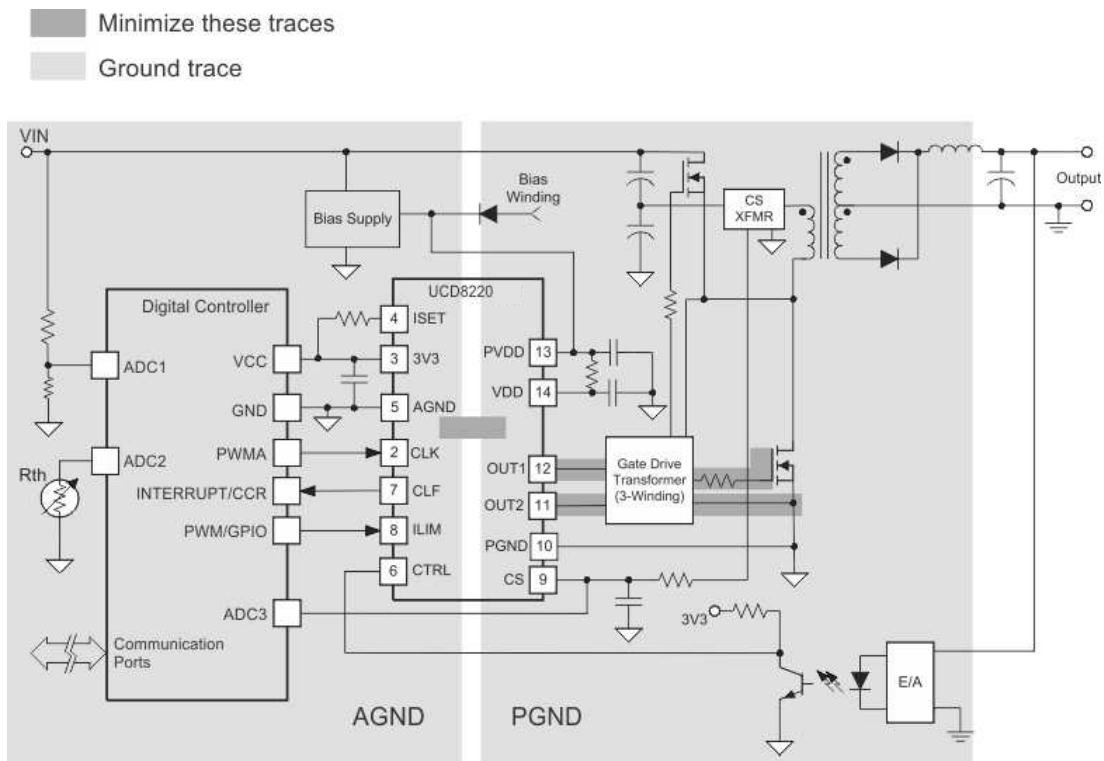

Figure 41. UCD8220 Layout Example

10.3 Thermal Considerations

The useful range of a driver is greatly affected by the drive power requirements of the load and the thermal characteristics of the device package. In order for a power driver to be useful over a particular temperature range the package must allow for the efficient removal of the heat produced while keeping the junction temperature within rated limits. The UCD8220 device is available in the PowerPAD integrated circuit package, HTSSOP, to cover a range of application requirements. The package has an exposed pad to enhance thermal conductivity from the semiconductor junction.

As shown in (4) in the [Related Documentation](#) section, the PowerPAD integrated circuit packages offer a leadframe die pad that is exposed at the base of the package. This pad is soldered to the copper on the PC board (PCB) directly underneath the device package, reducing the $R_{\theta JA}$ down to 37.47°C/W. The PC board must be designed with thermal lands and thermal vias to complete the heat removal subsystem, as discussed in (3) in the [Related Documentation](#) section.

Note that the PowerPAD integrated circuit package is not directly connected to any leads of the package. However, the PowerPAD is electrically and thermally connected to the substrate which is the ground of the device. The PowerPAD integrated circuit package should be connected to the quiet ground of the circuit.

11 Device and Documentation Support

11.1 Documentation Support

11.1.1 Related Documentation

For related documentation see the following:

- (1) *Modeling, Analysis and Compensation of the Current-Mode Converter*, [SLUA101](#)
- (2) *MSP430F1232, MSP430x11x2, MSP430x12x2 MIXED SIGNAL MICROCONTROLLER*, [SLAS361](#)
- (3) *PowerPAD Made Easy*, [SLMA004](#)
- (4) *PowerPAD Thermally Enhanced Package*, [SLMA002](#)
- (5) *Power Supply Seminar SEM-300 Topic 2, Closing the Feedback Loop*, [SLUP068](#)
- (6) *Power Supply Seminar SEM-1400 Topic 2: Design And Application Guide For High Speed MOSFET Gate Drive Circuits*, [SLUP133](#)
- (7) *Power Supply Seminar SEM-1600 Topic 6: A Practical Introduction to Digital Power Supply Control*, [SLUP224](#)
- (8) *Practical Considerations in Current Mode Power Supplies*, [SLUA110](#)

11.2 Trademarks

TMS320, TrueDrive, PowerPAD are trademarks of Texas Instruments. All other trademarks are the property of their respective owners.

11.3 Electrostatic Discharge Caution



These devices have limited built-in ESD protection. The leads should be shorted together or the device placed in conductive foam during storage or handling to prevent electrostatic damage to the MOS gates.

11.4 Glossary

[SLYZ022](#) — *TI Glossary*.

This glossary lists and explains terms, acronyms, and definitions.

12 Mechanical, Packaging, and Orderable Information

The following pages include mechanical, packaging, and orderable information. This information is the most current data available for the designated devices. This data is subject to change without notice and revision of this document. For browser-based versions of this data sheet, refer to the left-hand navigation.

PACKAGING INFORMATION

Orderable Device	Status (1)	Package Type	Package Drawing	Pins	Package Qty	Eco Plan (2)	Lead finish/ Ball material (6)	MSL Peak Temp (3)	Op Temp (°C)	Device Marking (4/5)	Samples
UCD8220PWP	ACTIVE	HTSSOP	PWP	16	90	RoHS & Green	NIPDAU	Level-2-260C-1 YEAR	-40 to 105	UCD8220	Samples

(1) The marketing status values are defined as follows:

ACTIVE: Product device recommended for new designs.

LIFEBUY: TI has announced that the device will be discontinued, and a lifetime-buy period is in effect.

NRND: Not recommended for new designs. Device is in production to support existing customers, but TI does not recommend using this part in a new design.

PREVIEW: Device has been announced but is not in production. Samples may or may not be available.

OBSOLETE: TI has discontinued the production of the device.

(2) **RoHS:** TI defines "RoHS" to mean semiconductor products that are compliant with the current EU RoHS requirements for all 10 RoHS substances, including the requirement that RoHS substance do not exceed 0.1% by weight in homogeneous materials. Where designed to be soldered at high temperatures, "RoHS" products are suitable for use in specified lead-free processes. TI may reference these types of products as "Pb-Free".

RoHS Exempt: TI defines "RoHS Exempt" to mean products that contain lead but are compliant with EU RoHS pursuant to a specific EU RoHS exemption.

Green: TI defines "Green" to mean the content of Chlorine (Cl) and Bromine (Br) based flame retardants meet JS709B low halogen requirements of <=1000ppm threshold. Antimony trioxide based flame retardants must also meet the <=1000ppm threshold requirement.

(3) MSL, Peak Temp. - The Moisture Sensitivity Level rating according to the JEDEC industry standard classifications, and peak solder temperature.

(4) There may be additional marking, which relates to the logo, the lot trace code information, or the environmental category on the device.

(5) Multiple Device Markings will be inside parentheses. Only one Device Marking contained in parentheses and separated by a "-" will appear on a device. If a line is indented then it is a continuation of the previous line and the two combined represent the entire Device Marking for that device.

(6) Lead finish/Ball material - Orderable Devices may have multiple material finish options. Finish options are separated by a vertical ruled line. Lead finish/Ball material values may wrap to two lines if the finish value exceeds the maximum column width.

Important Information and Disclaimer:The information provided on this page represents TI's knowledge and belief as of the date that it is provided. TI bases its knowledge and belief on information provided by third parties, and makes no representation or warranty as to the accuracy of such information. Efforts are underway to better integrate information from third parties. TI has taken and continues to take reasonable steps to provide representative and accurate information but may not have conducted destructive testing or chemical analysis on incoming materials and chemicals. TI and TI suppliers consider certain information to be proprietary, and thus CAS numbers and other limited information may not be available for release.

In no event shall TI's liability arising out of such information exceed the total purchase price of the TI part(s) at issue in this document sold by TI to Customer on an annual basis.

OTHER QUALIFIED VERSIONS OF UCD8220 :

- Automotive: [UCD8220-Q1](#)

NOTE: Qualified Version Definitions:

- Automotive - Q100 devices qualified for high-reliability automotive applications targeting zero defects

TUBE



*All dimensions are nominal

Device	Package Name	Package Type	Pins	SPQ	L (mm)	W (mm)	T (μm)	B (mm)
UCD8220PWP	PWP	HTSSOP	16	90	530	10.2	3600	3.5

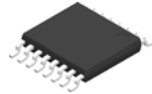

Images above are just a representation of the package family, actual package may vary.
Refer to the product data sheet for package details.

PWP0016A



PACKAGE OUTLINE

PowerPAD™ HTSSOP - 1.2 mm max height

PLASTIC SMALL OUTLINE

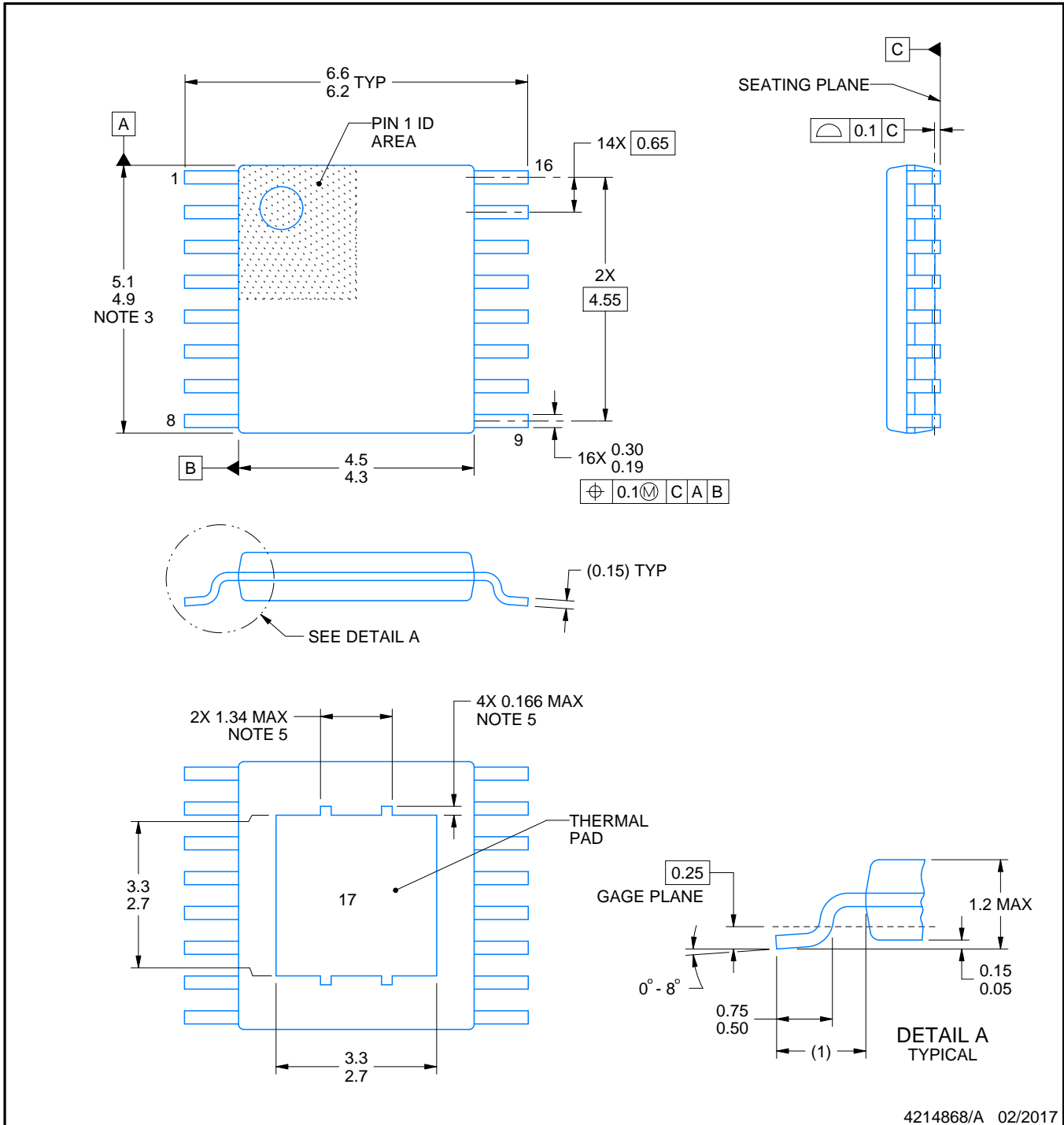

4214868/A 02/2017

NOTES:

PowerPAD is a trademark of Texas Instruments.

1. All linear dimensions are in millimeters. Any dimensions in parenthesis are for reference only. Dimensioning and tolerancing per ASME Y14.5M.
2. This drawing is subject to change without notice.
3. This dimension does not include mold flash, protrusions, or gate burrs. Mold flash, protrusions, or gate burrs shall not exceed 0.15 mm per side.
4. Reference JEDEC registration MO-153.
5. Features may not be present.

EXAMPLE BOARD LAYOUT

PWP0016A

PowerPAD™ HTSSOP - 1.2 mm max height

PLASTIC SMALL OUTLINE

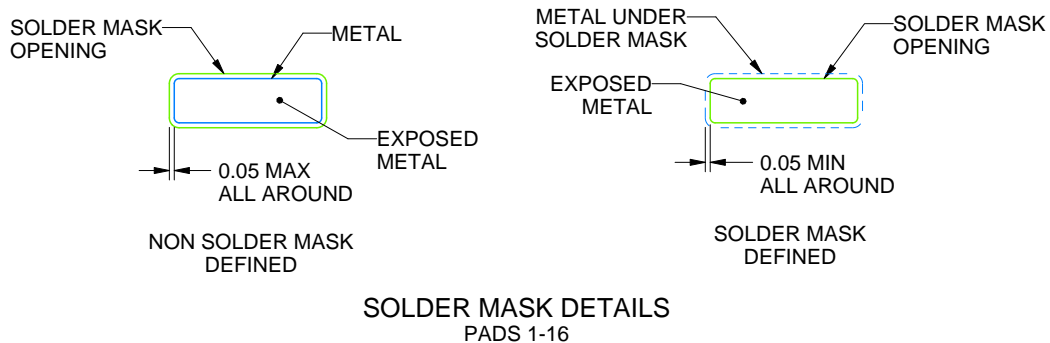
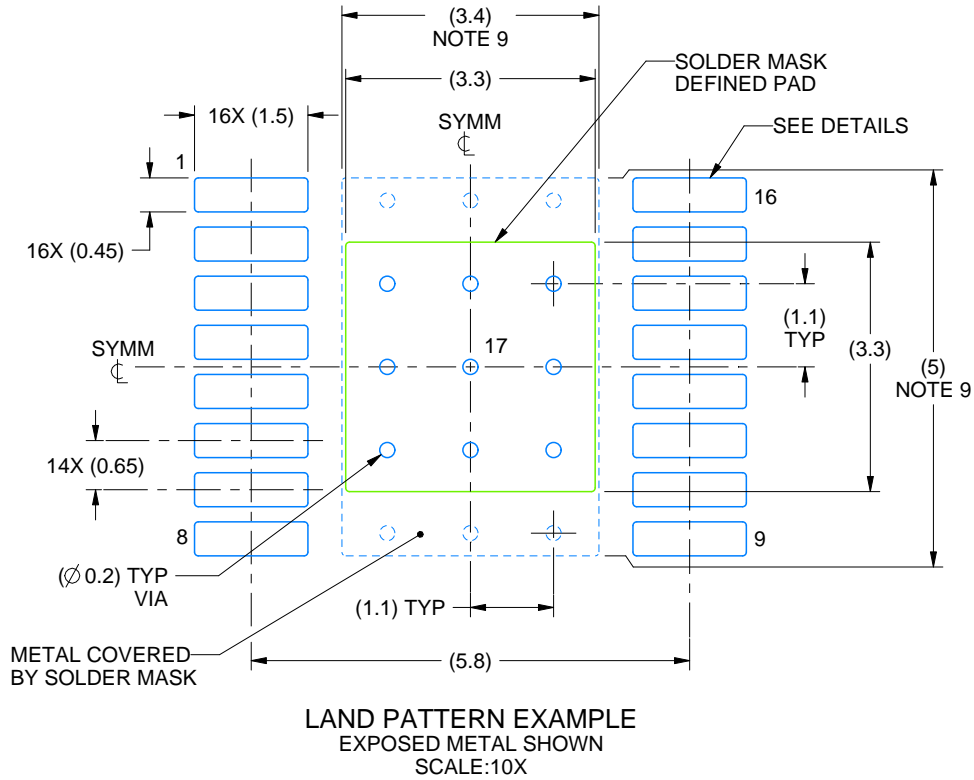

4214868/A 02/2017

NOTES: (continued)

6. Publication IPC-7351 may have alternate designs.
7. Solder mask tolerances between and around signal pads can vary based on board fabrication site.
8. This package is designed to be soldered to a thermal pad on the board. For more information, see Texas Instruments literature numbers SLMA002 (www.ti.com/lit/slma002) and SLMA004 (www.ti.com/lit/slma004).
9. Size of metal pad may vary due to creepage requirement.

EXAMPLE STENCIL DESIGN

PWP0016A

PowerPAD™ HTSSOP - 1.2 mm max height

PLASTIC SMALL OUTLINE

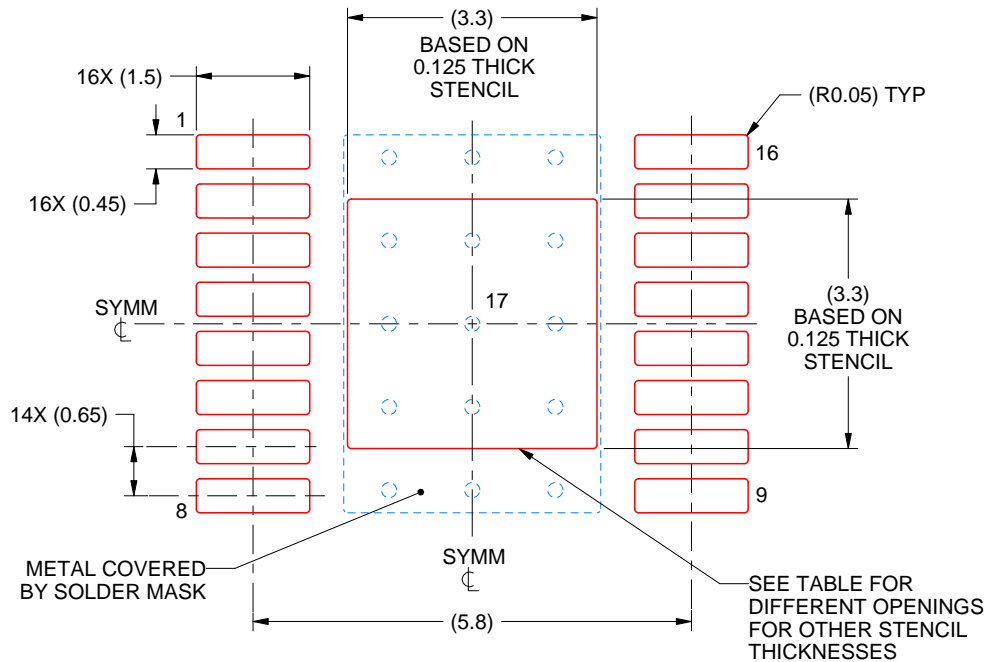

SOLDER PASTE EXAMPLE
 EXPOSED PAD
 100% PRINTED SOLDER COVERAGE BY AREA
 SCALE:10X

STENCIL THICKNESS	SOLDER STENCIL OPENING
0.1	3.69 X 3.69
0.125	3.3 X 3.3 (SHOWN)
0.15	3.01 X 3.01
0.175	2.79 X 2.79

4214868/A 02/2017

NOTES: (continued)

10. Laser cutting apertures with trapezoidal walls and rounded corners may offer better paste release. IPC-7525 may have alternate design recommendations.
11. Board assembly site may have different recommendations for stencil design.

GENERIC PACKAGE VIEW

RGW 20

VQFN - 1 mm max height

5 x 5, 0.65 mm pitch

PLASTIC QUAD FLATPACK - NO LEAD

This image is a representation of the package family, actual package may vary.
Refer to the product data sheet for package details.

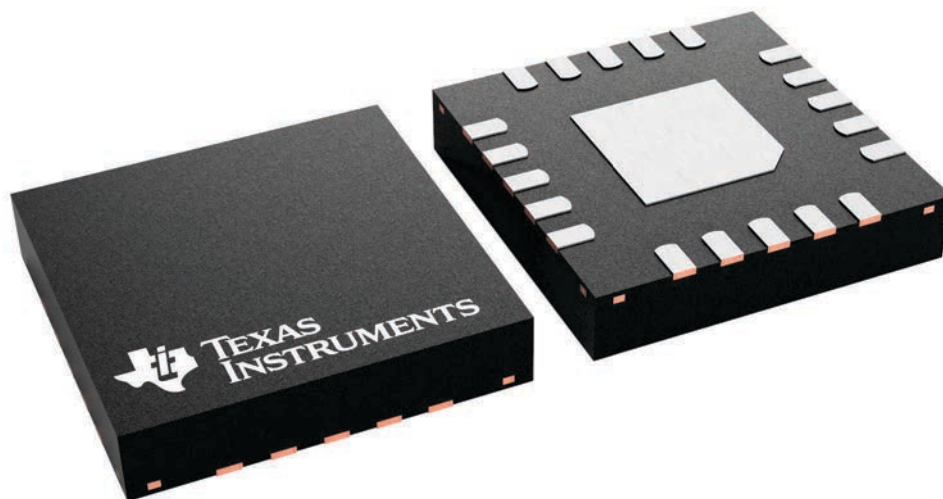

4227157/A

RSA (S-PVQFN-N16)

PLASTIC QUAD FLATPACK NO-LEAD



4205141/D 06/11

- NOTES:
- All linear dimensions are in millimeters. Dimensioning and tolerancing per ASME Y14.5M-1994.
 - This drawing is subject to change without notice.
 - Quad Flatpack, No-leads (QFN) package configuration.
 - The package thermal pad must be soldered to the board for thermal and mechanical performance.
 - See the additional figure in the Product Data Sheet for details regarding the exposed thermal pad features and dimensions.
 - Falls within JEDEC MO-220.

IMPORTANT NOTICE AND DISCLAIMER

TI PROVIDES TECHNICAL AND RELIABILITY DATA (INCLUDING DATA SHEETS), DESIGN RESOURCES (INCLUDING REFERENCE DESIGNS), APPLICATION OR OTHER DESIGN ADVICE, WEB TOOLS, SAFETY INFORMATION, AND OTHER RESOURCES "AS IS" AND WITH ALL FAULTS, AND DISCLAIMS ALL WARRANTIES, EXPRESS AND IMPLIED, INCLUDING WITHOUT LIMITATION ANY IMPLIED WARRANTIES OF MERCHANTABILITY, FITNESS FOR A PARTICULAR PURPOSE OR NON-INFRINGEMENT OF THIRD PARTY INTELLECTUAL PROPERTY RIGHTS.

These resources are intended for skilled developers designing with TI products. You are solely responsible for (1) selecting the appropriate TI products for your application, (2) designing, validating and testing your application, and (3) ensuring your application meets applicable standards, and any other safety, security, regulatory or other requirements.

These resources are subject to change without notice. TI grants you permission to use these resources only for development of an application that uses the TI products described in the resource. Other reproduction and display of these resources is prohibited. No license is granted to any other TI intellectual property right or to any third party intellectual property right. TI disclaims responsibility for, and you will fully indemnify TI and its representatives against, any claims, damages, costs, losses, and liabilities arising out of your use of these resources.

TI's products are provided subject to [TI's Terms of Sale](#) or other applicable terms available either on [ti.com](https://www.ti.com) or provided in conjunction with such TI products. TI's provision of these resources does not expand or otherwise alter TI's applicable warranties or warranty disclaimers for TI products.

TI objects to and rejects any additional or different terms you may have proposed.

Mailing Address: Texas Instruments, Post Office Box 655303, Dallas, Texas 75265
Copyright © 2023, Texas Instruments Incorporated