

THIS DRAWING IS UNPUBLISHED. RELEASED FOR PUBLICATION, 19 .
 © COPYRIGHT 19 BY AMP INCORPORATED. ALL INTERNATIONAL RIGHTS RESERVED.

LOC		DIST		REVISIONS				DATE	APPD
ZONE	LTR	DESCRIPTION		DATE	APPD				
G	14	P	F	G	ADDED 2-4 PER 0G3A-0037-02	04FEB02	JR/MS		

METRIC
 DIMENSIONS LISTED IN mm [INCHES]

AMP WIRE RANGE	UL E13288 Listed
16-14 AWG SOLID OR STRANDED	NOT APPLICABLE
SP LR7189 Certified	MILITARY P/N AND CLASS
NOT APPLICABLE	NOT APPLICABLE

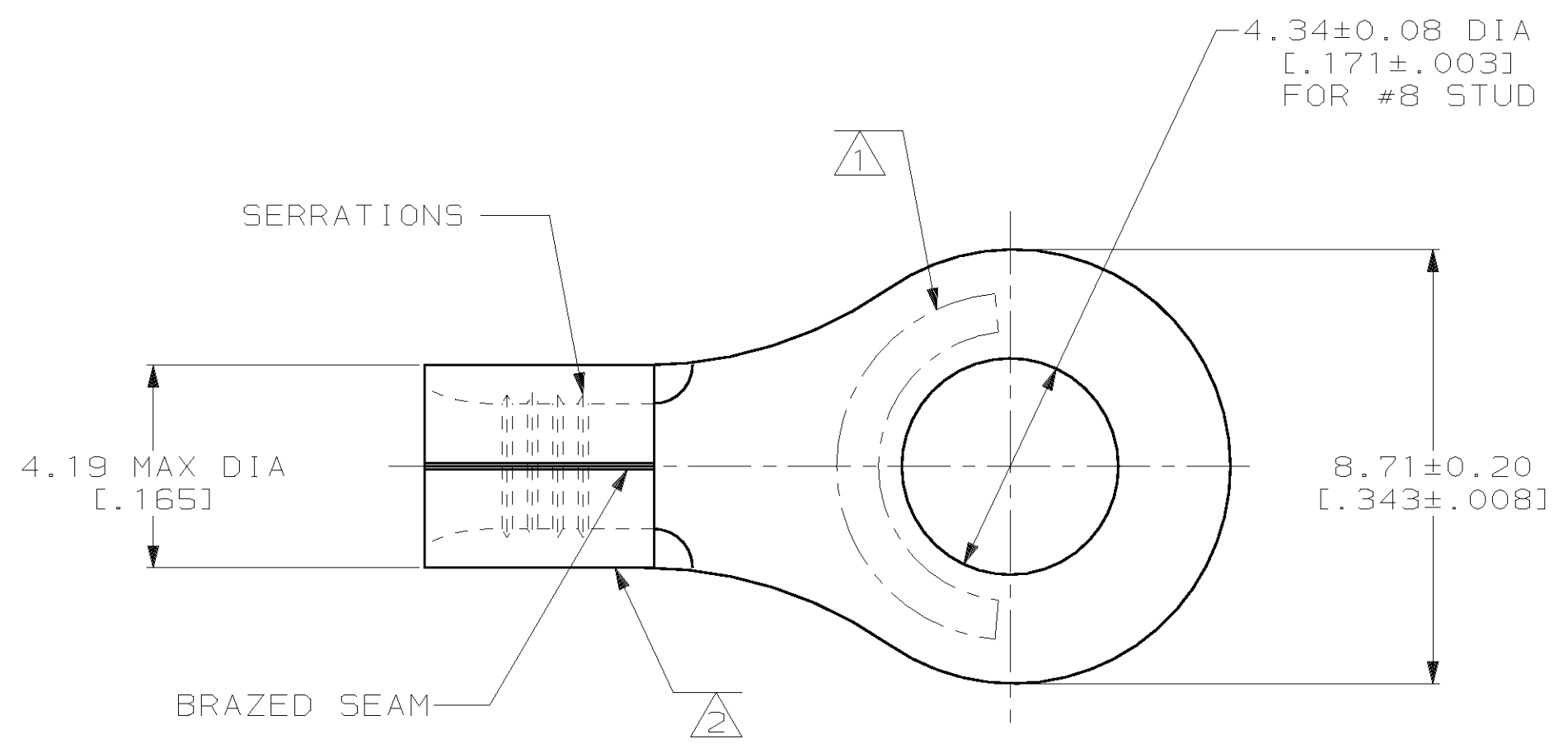

- ① STAMP AMP 16-14 APPROX AS SHOWN
- ② WIRE BARREL COLOR CODED ORANGE TO DENOTE NICKEL MATERIAL
- ③ PRE-PRODUCTION - FASR REQ

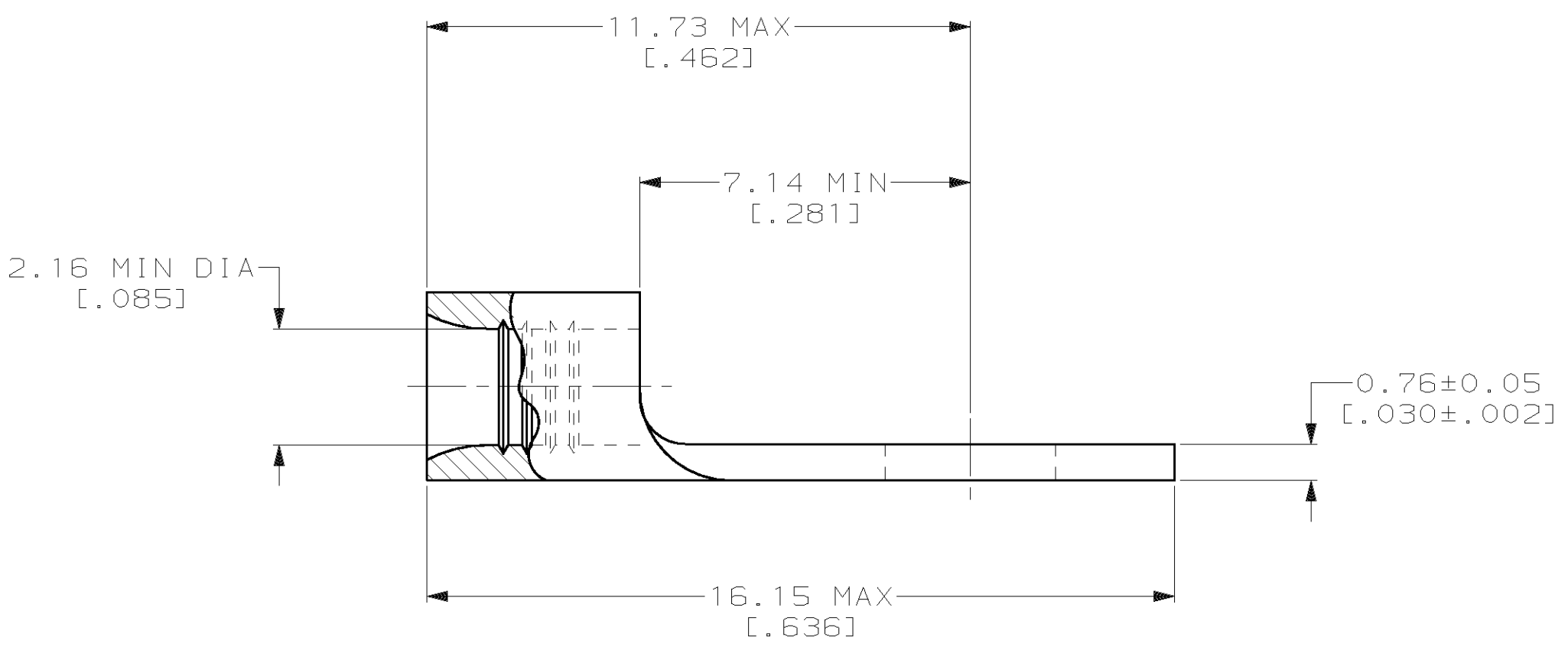

QUANTITY	PACKAGE TYPE	PART NO
100	LOOSE PIECE, BOX	8-322334-1
5,000	ON TAPE, REEL	③ 2-322334-4
----	LOOSE PIECE	322334

AMP INCORPORATED
CUSTOMER SERVICE SYSTEMS

FOR ADDITIONAL PRODUCT INFORMATION OR COPIES OF DRAWINGS AND TECHNICAL DOCUMENTS
 PRODUCT INFORMATION CENTER
 1-800-522-6752

FOR APPLICATION TOOLING INFORMATION
 TOOLING ASSISTANCE CENTER
 1-800-722-1111

FOR ORDER ENTRY
 1-800-526-5142

MAX RECOMMENDED OPERATING TEMPERATURE:
 649°C MAX

VOLTAGE RATING:
 NOT APPLICABLE

WIRE CROSS SECTIONAL AREA RANGE:
 1.04-2.62mm² [2,050-5,180] CIR MILS
 SOLID OR STRANDED

THIS DRAWING IS A CONTROLLED DOCUMENT FOR AMP INCORPORATED. IT IS SUBJECT TO CHANGE AND THE CONTROLLING ENGINEERING ORGANIZATION SHOULD BE CONTACTED FOR THE LATEST REVISION.

DO NOT SCALE PRINT. UNLESS SPECIFIED DIMENSIONS IN mm [INCHES] - TOLERANCES ON :
 2 PLC DEC ± -
 3 PLC DEC ± -
 ANGLES ± -

MATERIAL
 NICKEL PER ASTM B-162 ANNEALED

FINISH
 -

DR 4-15-93 TA BRINKMAN
 CHK 4-15-93 DA PATTERSON
 APPD 4-15-93 DE MILLER
 APPD 4-15-93 JL MECKLEY
 PRODUCT SPEC -
 APPLICATION SPEC -
 WEIGHT -

AMP AMP Incorporated
 Harrisburg, PA 17105-3608

NAME
 TERMINAL, RING TONGUE,
 HIGH TEMPERATURE,
 STRATO-THERM

SIZE CAGE CODE DRAWING NO
 C 00779 C=322334

SCALE 8:1 SHEET 1 OF 1